

# XMRPANIC

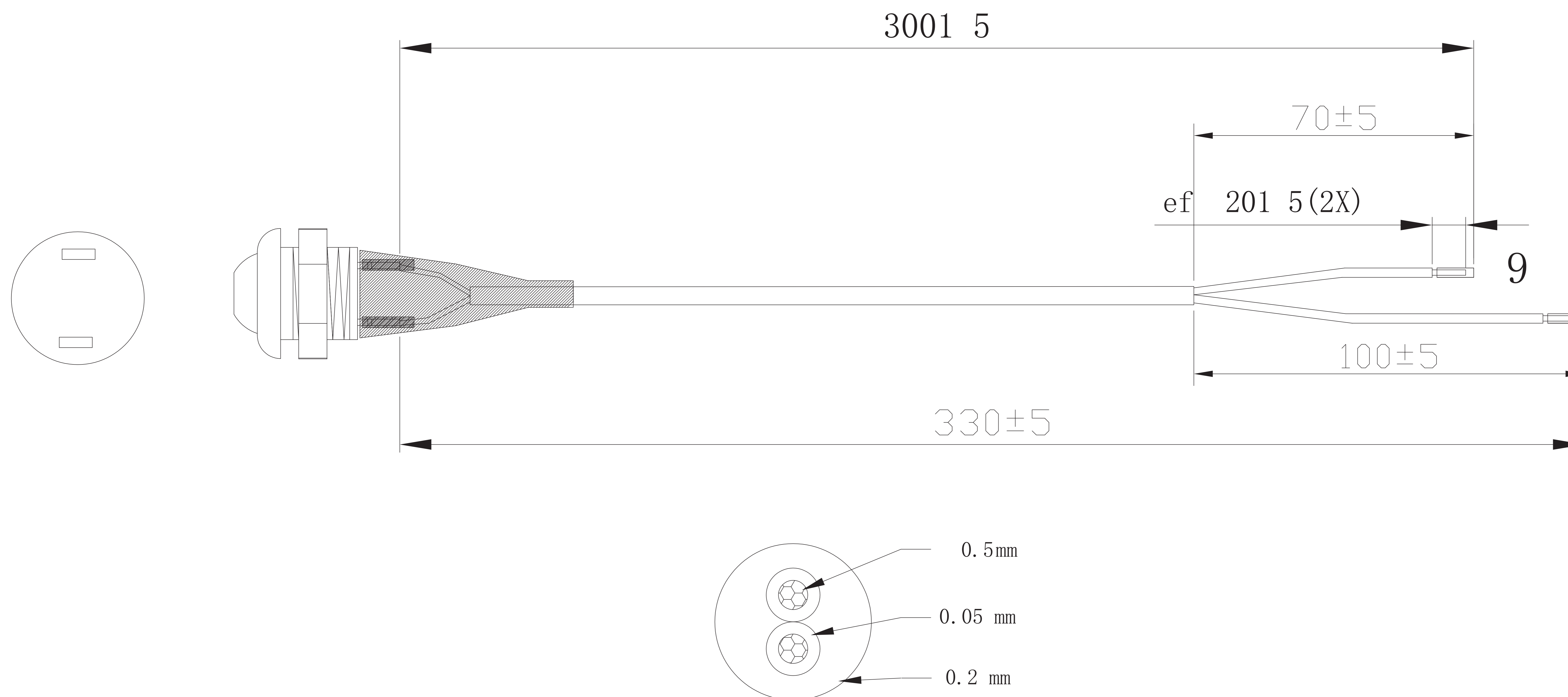

1. (20AWG\*2C)\*1C, PVC , OD:5.01 0.2 mm, ANT-CEIEC

2. PB12-2-M-RX-N

PART NO 01.05.01.04.06.61		PART NAME -D		DRAWING 1 SVT6.646.349	
PRODUCT NAME		SPEC		L= 300mm, CST	
MATERIAL		FINISH		DESIGN BY PGM 13-01-21	
( ) *+ ) TOLERANCE ( , * - . ) : / 0 - . / 0 - . 0-50mm 1 3 500-1000mm 1 15 50-200mm 1 5 1000-3000mm 1 25 200-500mm 1 10 3000mm45 1 1.5%23		ALL DIMENSIONS ARE IN MM		APPROVED BY	
SCALE		QUANTITY 1		SHEET 1 OF 1	