

X1 Pro Service Manual

Table of Contents

Chapter 1 Overview	4
1.1 Scope of Application	4
1.2 Safety matters.....	4
Chapter 2 Appearance diagram and operation function key description.....	5
2.1 Schematic view.....	5
Chapter 3 Combined modes	7
3.1 Modes	7
3.2 How to enter each mode.....	7
3.3 PC Mode	7
3.3.1 Preface.....	7
3.3.2 Connection Procedure	7
IMG-22	8
Chapter 4 Disassembling Parts for Maintenance	9
4.1 Disassembly Procedure.....	9
Parts Disassembly Diagram	10
Chapter 5 Unit Circuit Introduction.....	11
5.1 DMR Digital Circuit Signal Flow Block Diagram.....	11
5.1 Circuit Composition	11
5.2 Receive Section	12
5.3 Transmitter Section	13
5.4 Frequency Synthesizer/Baseband Processor.....	14
5.5 Power Supply	15
5.6 Control System	16
Chapter 6 Functional Description and Parameter Settings	18
6.1 Main Functions	18
6.1.1 Channels	18
6.1.2 Power saving function	19
6.1.3 Power switching function	19
6.1.4 Squelch level.....	19
6.1.5 Receiving and originating calls	19
6.1.5.1 Selecting an area	19
6.1.5.2 Selecting the intercom channel	19
6.1.5.3 Receiving and replying to intercom calls	20
6.1.5.4 Receiving and replying to group calls.....	20
6.1.5.5 Receiving and replying to a single call	20
6.1.5.6 Receiving an all-call	20
6.1.5.7 Originating an Intercom Call	21
6.1.6 Low Battery Alarm Alert Function	22
6.1.7 TOT function.....	22

6.2 Parameter setting	22
6.2.1 Setting the power level	22
6.2.2 CTCSS function	23
6.2.3 CDCSS function	24
Chapter 7 Complete Machine Tuning and Testing	25
7.1 Required Test Equipment	25
7.2 Commissioning Instructions	27
7.3 Table 3 Launch Section	27
Chapter 8 Performance Indicators	30
Chapter 9 Specifications	32
Appendix 1 Material Schedule (Electronic Part)	33
Appendix 2 Material Breakdown (Structural Part)	39
Appendix 1 X1 pro Bit Number Diagram	42
Appendix 2 x1 pro Schematic Diagram	44
Attachment 3 x1 pro Block Diagram	46
Attachment 4 x1 pro Package Diagram	47

Chapter 1: Overview

1.1 Scope of Application

This manual is intended for technical personnel familiar with communication systems and experienced in maintenance. It includes all necessary materials and current published data required for servicing this device. Updates after publication may occur; supplemental materials such as "Maintenance Bulletins" and "Manual Revisions" should be referenced when needed.

Please read this manual carefully before servicing the device.

1.2 Safety Precautions

Energy Radiation from Walkie-Talkies:

Walkie-talkies generate and emit electromagnetic energy. The electromagnetic radiation safety of Oubiao walkie-talkies is designed to fully comply with national and international standards. To ensure optimal communication performance and safety from electromagnetic radiation, hold the walkie-talkie vertically to the ground during use, with the microphone positioned 2.5 – 5 cm from the mouth.

Electromagnetic Interference:

To prevent electromagnetic interference, turn off the walkie-talkie in locations where its use is explicitly prohibited (e.g., hospitals, airports).

Explosive Environments:

In explosive environments (e.g., gas, dust, or smoke), it is best to turn off the walkie-talkie.

Turn off the walkie-talkie at gas stations or when parked at gas stations.

Turn off the walkie-talkie near electric detonators.

Never replace or charge batteries in potentially explosive atmospheres where explosive gases may be present.

Antenna Damage:

Do not use the walkie-talkie if the antenna is damaged. Contact between damaged antennas and the skin may cause mild burns.

Replacing Components:

When replacing any components, ensure they match the specified models. Do not arbitrarily replace components that do not conform to the company-provided specifications.

Maintenance Services:

To facilitate equipment maintenance, a complete service system has been established, including reference materials such as schematics, PCB diagrams, and adjustment procedures.

Chapter 2: Appearance Diagram and Operating Buttons Description

Appearance Diagram

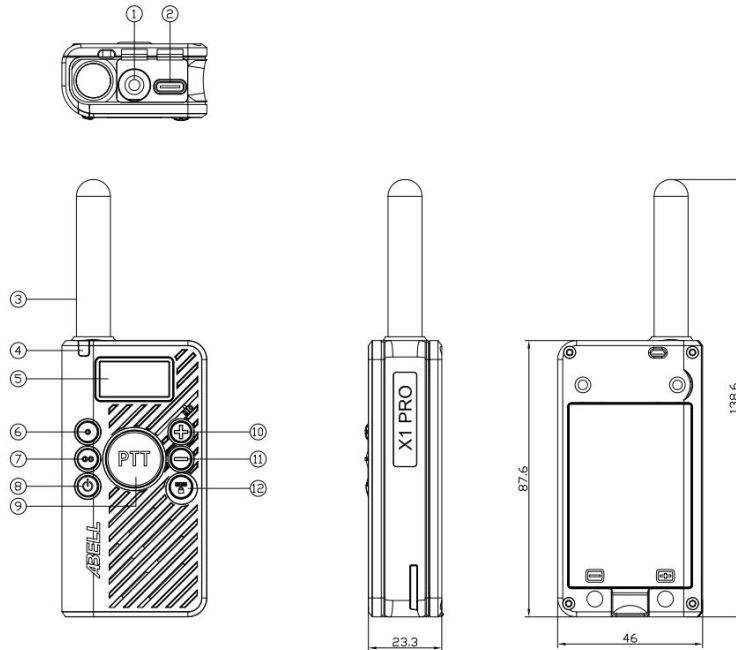

1.Headphone Jack

2.Charging/Programming Port

3.Antenna

4.Indicator Light

Lights up red when transmitting.

Lights up green when the walkie-talkie is powered on, receiving non-encrypted calls or data, or detecting air activity.

Flashes red when the battery voltage is low.

5.Display Screen

6.Channel + (Short Press), Zone Switching (Long Press)

7.Channel - (Short Press), Power Switching (Long Press)

8.Power Button

In the power-off state, long press this button to turn on the device.

In the power-on state, long press this button to turn off the device.

9.PTT (Push-to-Talk) Switch

Press this switch to call the other party via the microphone.

Release the switch to receive calls.

10.Volume +

11.Volume -

12.Menu Lock

Long press this button to lock all keys.

To unlock, long press the button again.

Chapter 3: Operating Modes

3.1 Modes

Mode Type Function

User Mode For general operation.

PC Mode Use this mode to configure the device with an external programming cable connected to a PC.

Debug
Mode Enter debug mode via programming software.

3.2 How to Enter Each Mode

Mode Type Steps

User Mode Turn on the power switch.

PC Mode Connect to a PC and control via programming software.

Debug Mode Access debug mode through programming software.

3.3PC Mode

3.3.1Introduction

Connect the walkie-talkie to a PC using a programming cable. Run the programming software (Oubiao X1 Pro Programming Software) on the PC to configure the device. Figure 1 illustrates the programming setup process on a PC.

3.3.2Connection Steps

- 1) Use the interface cable to connect the X1 Pro to a PC.
- 2) Run the programming software (Oubiao X1 Pro Programming Software).
- 3) Set up the communication port.
- 4) Perform various programming operations on the walkie-talkie.
- 5) Indicator Lights During Data Transmission:

The red light flashes when the handheld device sends data.

The green light flashes when the handheld device receives data.

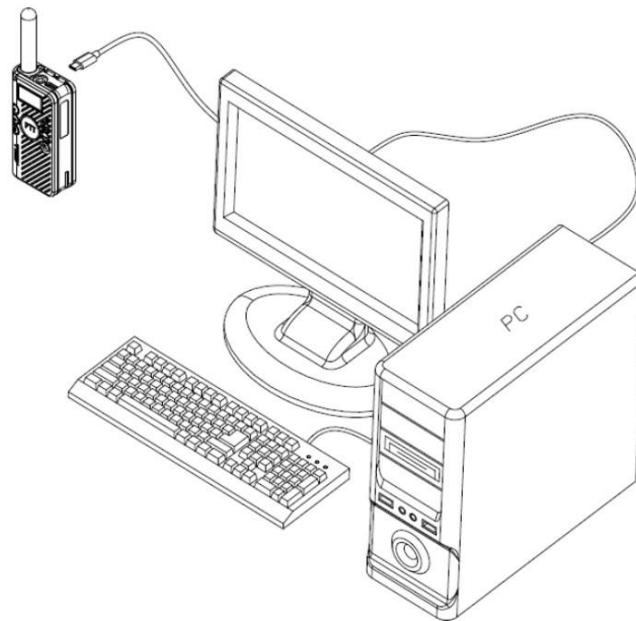

Important Notes:

The data stored on the PC must match the model of the communication device when writing to EEPROM.

Ensure the software is running and the cable is connected before turning on the handheld device.

Do not press the [PTT] button during data transmission or reception.

Programming Cable Description (Optional PC Programming Interface Cable)

The programming cable connects the X1 Pro to a PC. The PC programming interface cable links the port on the X1 Pro to the USB port of the computer.

Programming Software Description

The Oubiao X1 Pro Programming Software (pre-installed) allows users to configure the X1 Pro via the programming interface cable.

Using PC Programming

When transmitting data from the programming PC to the handheld device, the target data (basic communication parameters) can be modified.

Frequency range values are automatically generated when setting the frequency type, so manual adjustments are typically unnecessary. Modify values only when required.

Chapter 4: Disassembly During Maintenance

4.1 Disassembly Steps



1. Loosen the screws
2. Remove the back clip



7. Lift up the back cover

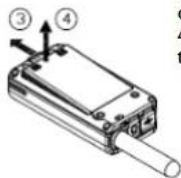

3. Push back the battery door catch
4. Lift the battery door upward at the end of the door.

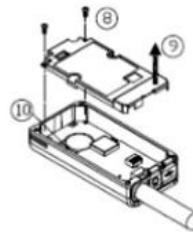

8. Loosen the two screws on the aluminum cover
9. Lift the aluminum cover upwards
10. Loosen the speaker wire

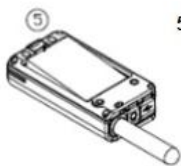

5. Lift the battery up at the battery end

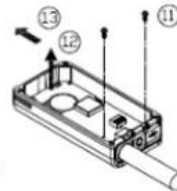

11. Loosen the two screws on the PCBA.
12. Lift up the PCBA
13. Pull out the PCBA to the left after the end of the PCBA is high out of the face shell.



6. Unscrew the 6 nuts on the rear case.

4.2 Component Exploded Diagram

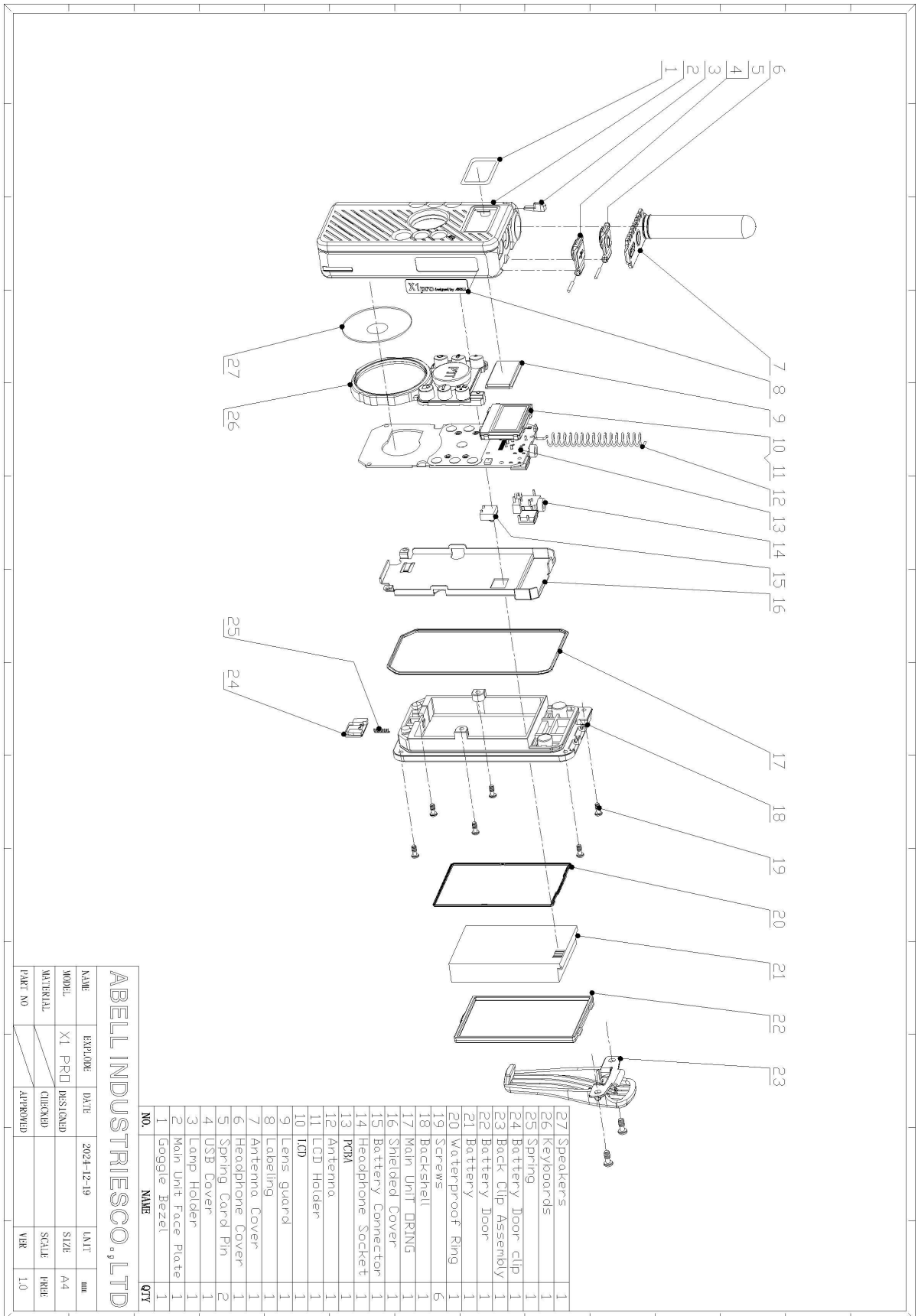

Chapter 5: Circuit Unit Description

5.1 DMR Digital Circuit Signal Flow Diagram

The DMR digital circuit block diagram shows the 4FSK digital signal channel flow:

Transmission: The voice signal enters the NJM2904V amplifier through the MIC, is sent to the HF6853 DSP for digital signal processing into a 4FSK modulated signal, and is then transmitted through the VCO and crystal modulation circuits.

Reception: The received 4FSK digital modulated signal is processed by the HF6853 DSP and demodulated into 4FSK audio signals by the AMBE3000. These signals are amplified by the TDA2822 power amplifier to drive the speaker (SP).

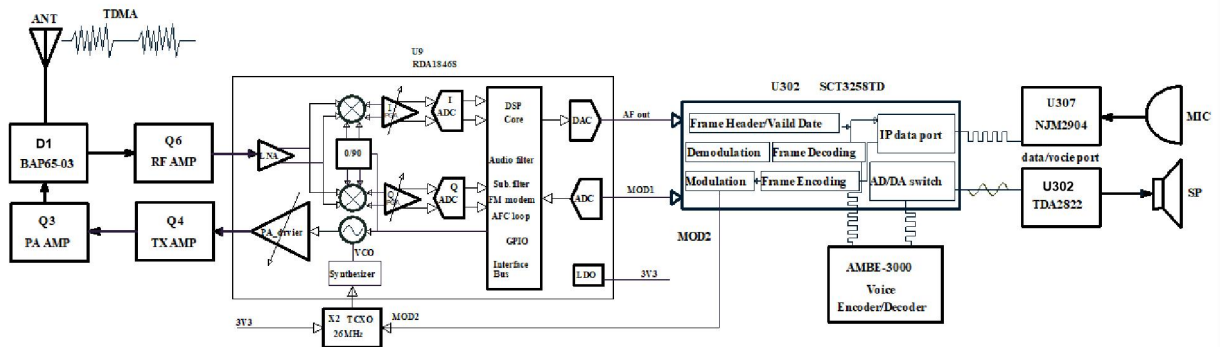

DMR Circuit Structure

5.2 Circuit Composition

The walkie-talkie is composed of the following circuits:

Microprocessor-controlled circuit

Receiving circuit

Transmitting circuit

Carrier frequency/baseband processing circuit

Audio amplifier circuit

Battery/power circuit

The RF carrier signal is directly generated by the RF/baseband processing chip, and the frequency band can be set using programming software on a PC. Refer to the block diagram for the overall circuit structure.

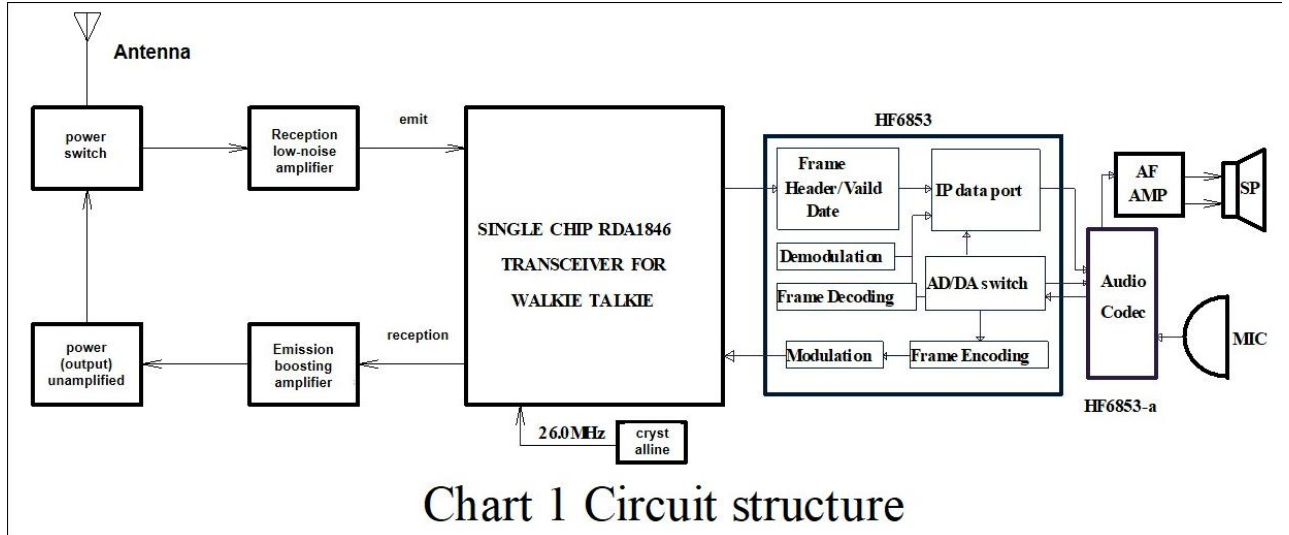

5.2 Receiving section

Front-end RF amplifier

The signal received from the antenna enters the low-pass filter and the receive/transmit switching diode circuit (D5 and D6 are disconnected), and the signal that is not filtered by the L11.C59 bandpass filter enters the RF amplifier Q6 to be amplified, and after the signal is amplified by Q6, the RF signal is then passed through the L12 and the C57 to enter the U9 (RFIN). (Refer to Figure 2)

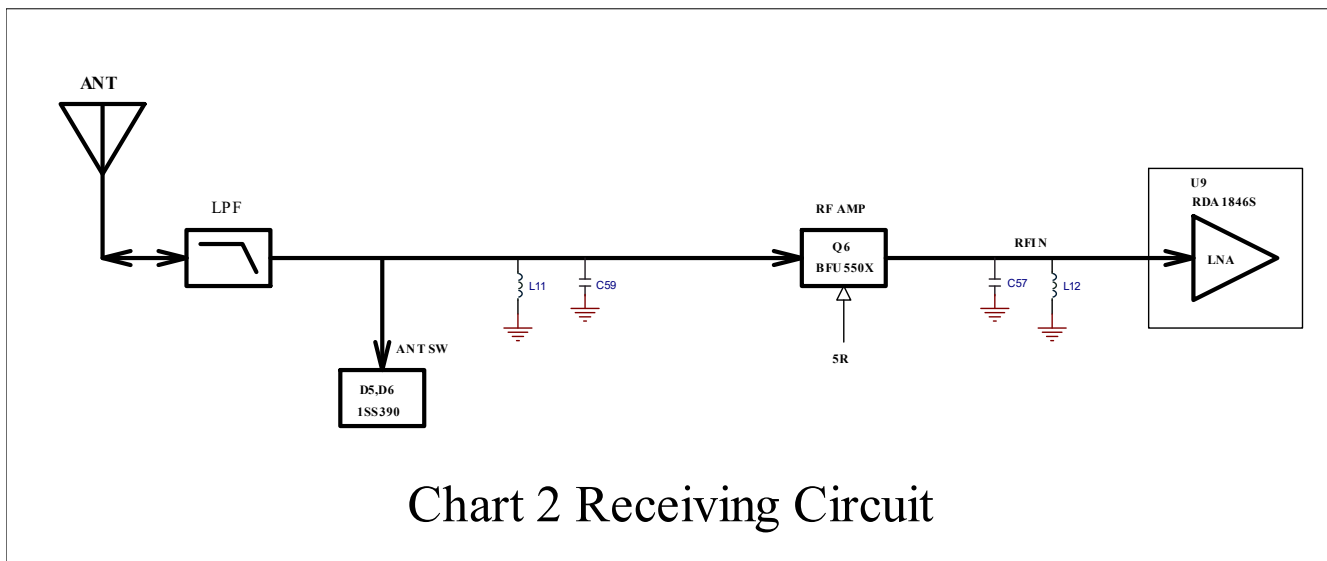

5.3 Transmitter section

(1) RF power amplifier

The RF signal generated from U9 passes through the preamplifier Q8, and the amplified signal is then amplified by the driver amplifier Q4 and sent to the final power amplifier Q3 to output 1.5W (the intercom is set to generate RF power amplifier output of 1.5W when it is set to high power, and to generate RF power amplifier output of 0.5W when it is set to low power)

(2) Antenna changeover switch and LPF

Before the RF signal reaches the antenna terminal, the RF amplifier output signal is fed to the antenna through D1, D3, and D5. D6 transmit/receive conversion circuits, and then filtered out of harmonics by L28, L29, and L30 low-pass filters. D1, D3, and D5 D6 are turned on (conduction) in the transmit mode, and turned off (isolation) in the receive mode.

(3) Power Control

Power control circuit to stabilize the transmit output power by detecting the drain current of the terminal amplifier field effect tube. Voltage comparison circuit, U8 (2/2) compares the voltage obtained from the final stage current with the reference voltage set by the microprocessor. The power control voltage is proportional to the difference between the auto-detection voltage output from U8 (1/2) and the reference voltage. This output voltage controls the field effect tube power amplifier and maintains the transmitter output power constant. The output power of the transmitter section can be changed by the microprocessor, where the reference voltage is changed to control the output power.

(4) Temperature Protection Circuit

When the temperature of the thermistor (TH1) reaches 80° C, the protection circuit turns on D7 to protect the final amplifier (Q3) from overheating. (Refer to Fig. 3)

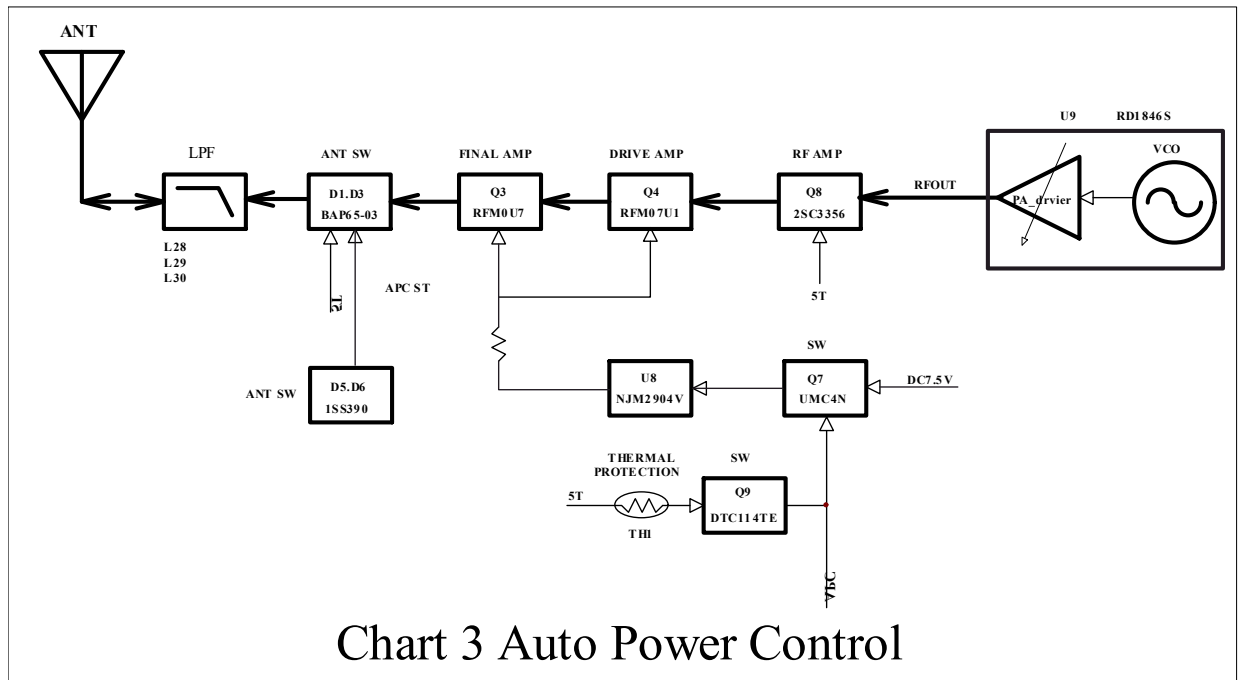

5.4 Frequency Synthesizer/Baseband Processor

The U9 processing chip internally includes a phase locker, voltage controlled oscillator, mixer, IF, and baseband processor . (Refer to Figure 4)

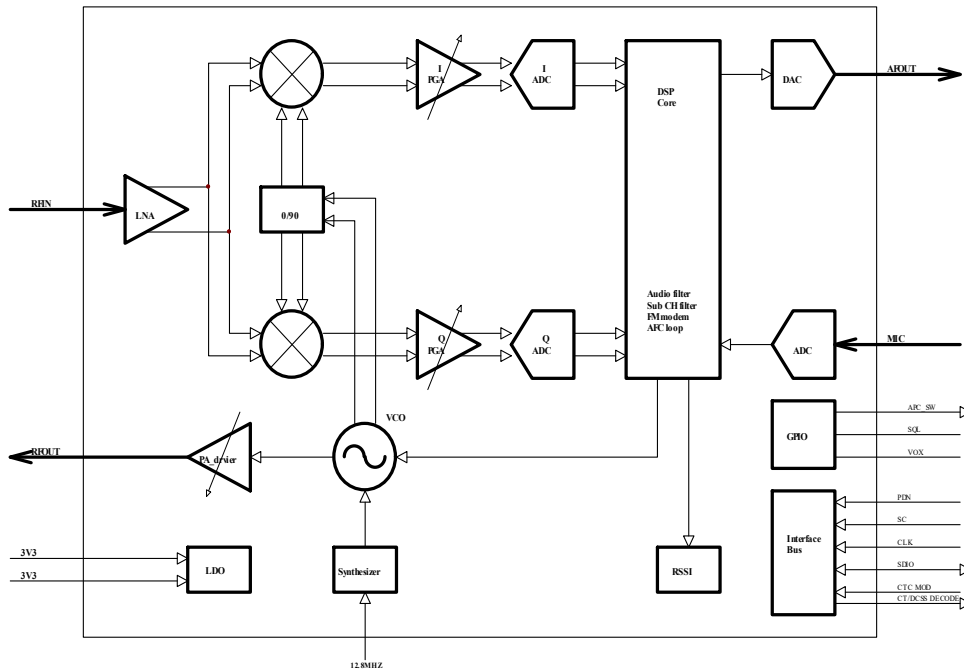

Chart 4 RD1846S

(1) Phase Locker

The phase locker has a step frequency of 5 or 6.25 KHz. 12.8 MHz reference oscillator signals are divided in phase-locked loop U9 by a mixing counter and generate a reference frequency of 5 or 6.25 KHz.

(2) Noise Suppression

The noise detection by U9 is whether it is above or below a preset value and generates a high/low level into the SQL port of the microprocessor U300. Microprocessor U300 decides whether to output sound from the speakers by detecting the incoming high/low level (To output sound through the speakers, microprocessor U300 sends a high level signal to the FM MUTE control link through Q308 and turns on audio amplifier U302).

(3) QT/DQT encoding

The received carrier frequency signal in the U300 demodulation out of the audio signal by the filter to filter out unwanted signals, the signal is then converted into a pulse signal by the U300 analog-to-digital converter into the microprocessor U300 (CTC/CDCSS DECODE). The microprocessor U300 determines whether the QT or DQT matches the set value and controls the FM MUTE and speaker output sound according to the result of the noise suppression circuit.

(4) Audio amplifier

The processed audio signal demodulated by U302 is amplified by VR1 volume control circuit and then by audio power amplifier U306 to drive the speaker.

(5) Transmit Audio

The transmitting voice signal is generated by the built-in microphone (M1) or external microphone, and the signal is modulated inside U300 after the maximum frequency deviation is adjusted by the audio processor U307.

(6) Wide/Narrow Band Conversion

Wide/narrow band can be enabled through the frequency writing software to set wide/narrow band for each channel, and the wide/narrow conversion is completed by the U300 baseband processor.

(7) QT/DQT encoding

QT data is generated internally by the audio baseband processor U300, and the signal passes through the CR low-pass filter to optimize the waveform into the U300 chip for modulation, and the QT frequency offset is adjusted by the (U300) chip.

DQT data is generated internally by the audio baseband processor U300, the signal is optimized by CR low-pass filter to enter the X2 clock crystal for modulation, and the DQT frequency bias is adjusted internally by the audio baseband processor U300.

(8) QT/DQT Coding

QT data is generated internally by the audio baseband processor U300, the signal is optimized by CR low-pass filter to enter the U300 chip for modulation, and the QT frequency bias is adjusted by the (U300) chip.

DQT data is generated internally by audio baseband processor U300, the signal is optimized by CR low-pass filter to enter X2 clock crystal for modulation, and DQT frequency bias is adjusted internally by audio baseband processor U300.

(9) VOX

The microphone (M1) generates a signal which is detected by the U307 signal level whether it is higher or lower than the preset value, and generates a high/low level into the VOX DET port of the microprocessor U300. The microprocessor U300 decides whether to turn on transmitting by detecting the incoming high/low level. (Refer to Figure 5)

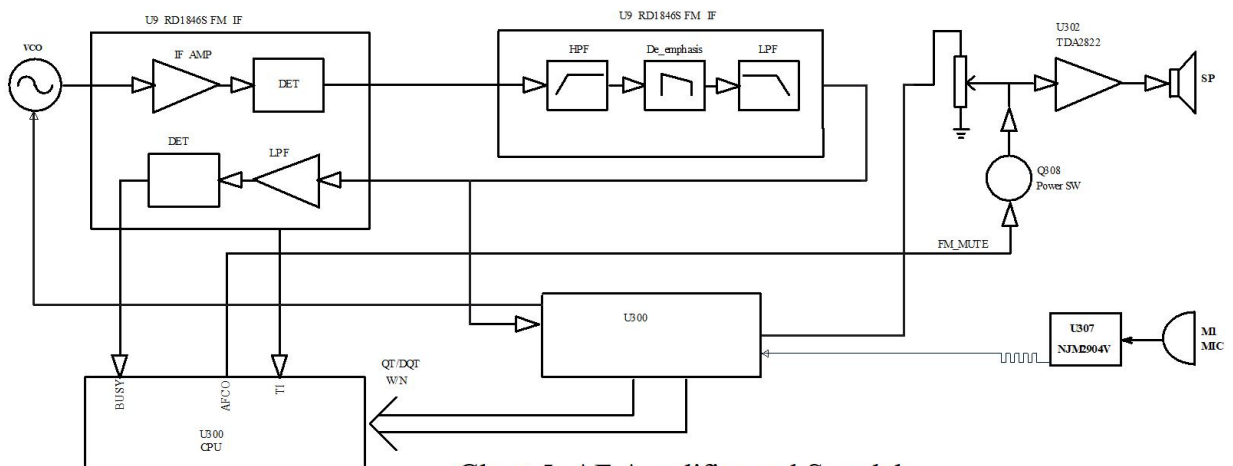

Chart 5 AF Amplifier and Squelch

(10) Voice Announcement

The Chinese/English voice announcement signal is generated from U300, and the signal is amplified through the VR1 volume control circuit and then through the audio power amplifier U302 to drive the speaker. (Chinese/English voice announcement signals include battery level announcement, alarm sound, and power channel announcement)

5.5 Power supply

From L309 input VCC3.6V through U306 regulator output 3V3, then L311 regulator output 3V3 to U300. CPU power supply. X2 crystal to provide power, U306 regulator output RF3V3 to U9 RD1846S to provide power. When the walkie-talkie works in the transmit mode microprocessor U300/TX_CTL. control U301 output 5T to provide power for the transmit circuit. When operating in receive mode microprocessor U300/RX_CTL outputs a high level to control Q313 (5R) to provide power to the receive circuit. (Refer to Figure 6)

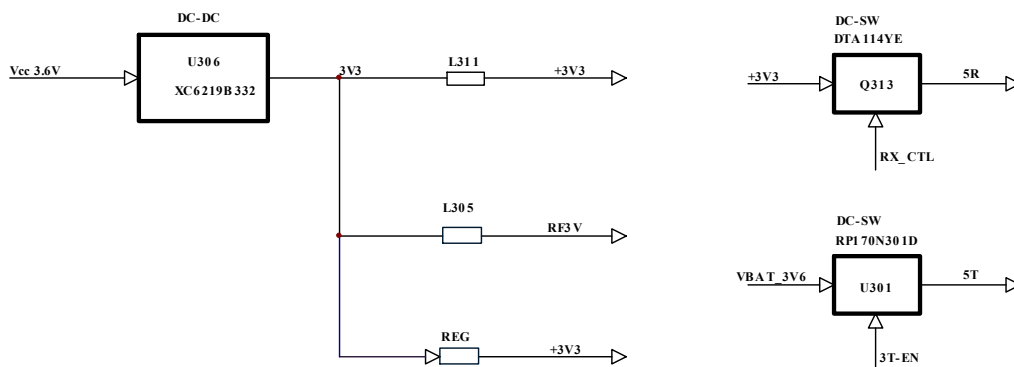

Chart 6 DC-SW

5.6 Control system

Microprocessor:

The intercom is turned on, the microprocessor (CPU U300) reads the data from the memory, the function keys (K1 K2 K3 K4 K5), the PTT key (K1), and other input signals such as squelch detection change channel coding LCD display, etc., and the microprocessor controls the frequency output by sending the correct frequency information to the U9 RD1846S, and the microprocessor's clock is used with the 26.0 MHz oscillator generated. (Refer to Figure 7)

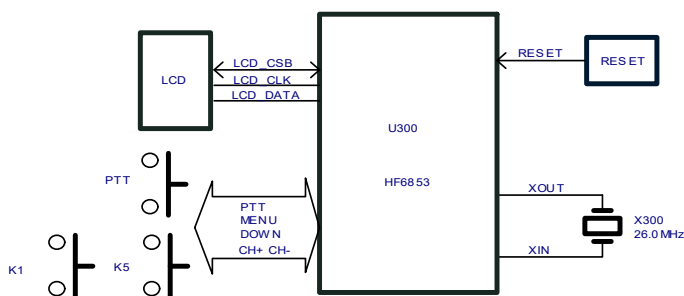

Chart 7 CPU

Battery Low Voltage Warning:

Battery voltage is monitored through the U300 microprocessor. A low battery beep will sound when below the low battery warning voltage.

(1) During launch, when the battery voltage falls below the Low Battery Alarm Voltage (preset at 3.3V) the red LED flashes and the Low Battery Beep sounds “Low Battery, Please Charge” .

(2) When the battery voltage drops below the lockout voltage, the handheld will stop transmitting immediately, and there will be a beep when the PTT switch is pressed, and a “low battery, please charge” beep when it is released. (Refer to Figure 8)

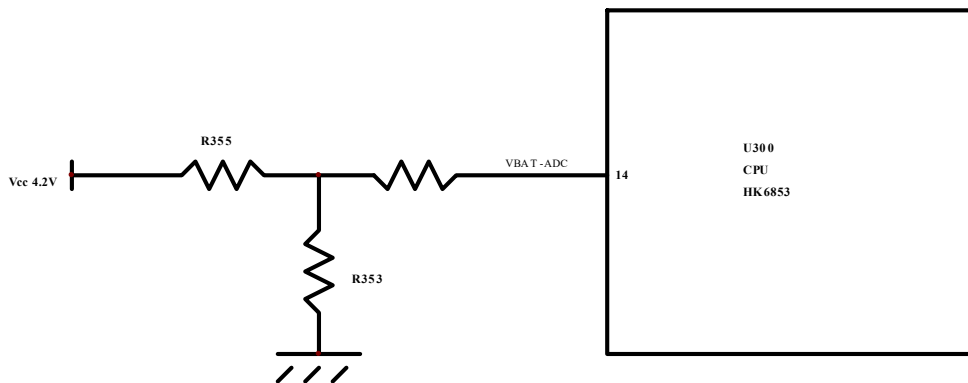

Chart 8 LOW-BATT

6.1 Functional description and parameterization

Key Features

6.1.1 reproach

The unit can store 32 channels in the main unit and 2 in the area capacity, 16 channels in each area.

6.1.2 power saving feature

In order to save battery power and extend standby time. Users can select the power saving level through the frequency writing software.

Enter power saving mode 5 seconds after power on or 5 seconds after no operation and no call.

6.1.3 Power switching function

1. The power level of the current channel can be selected through the frequency writing software.
2. The power level can be switched by long-pressing the channel-button.
Now there are only two available classes, high power and low power.

6.1.4 static noise level

0-9 levels of squelch depth level can be selected, 1 for the shallowest easy to receive weak signals, 9 levels of the most stringent need a stronger signal to receive, relatively small background noise, each level interval of about 1 dbm, 0 level is out of control, there is a squelch hysteresis.

6.1.5 Receiving and initiating calls

6.1.5.1 Selection of areas

A zone is a group of channels. The intercom can support up to 2 zones with a maximum of 16 channels per zone.

Process:

Press and hold the Channel+ button to switch zones.

When switching is complete, the display screen will show Z1 or Z2.

6.1.5.2 Selecting the intercom channel

Process:

Once the desired zone is set (if there are multiple zones in the intercom), press the Channel+ or Channel- button briefly to switch channels.

6.1.5.3 Accepting and replying to intercom calls

Process:

After the channel, user ID or talkgroup ID is set, you can accept or reply to calls

The LED indicator lights red when the intercom is transmitting and green when the intercom is receiving.

6.1.5.4 Receiving and replying to group calls

To receive calls from a user group, the intercom must be configured to belong to that talkgroup.

The LED indicator lights green.

Hold the intercom in a vertical position and 1 to 2 inches (2.5 to 5.0 cm) from your mouth. If the Channel Idle Indication feature is enabled, when you release the PTT key while transmitting the intercom, you will hear a short beep indicating that the channel is idle and waiting for you to answer.

Press the PTT key to answer the call. The LED indicator lights red.

Wait for the Call Allowance tone to end (if activated), then speak clearly into the microphone.

Release the PTT key to answer.

If there is no voice activity for a predetermined time period, the call is terminated.

6.1.5.5 Receiving and responding to single calls

A single call is a call from one individual intercom to another individual intercom. There are two types of single calls. In the first type, intercom presence detection is performed before the call is prepared, while in the other type the call is prepared immediately.

When your intercom is selected, the LED lights green. Agents can program only one of these two call types into the intercom.

Process:

When you receive a single call:

The LED indicator lights green.

Hold the intercom in a vertical position and 1 to 2 inches (2.5 to 5.0 cm) from your mouth. If the Channel Idle Indication feature is enabled, you will hear a short beep when you release the PTT key while transmitting the intercom.

Tone, indicates that the channel is free and waiting for your answer.

Press the PTT key to answer the call. The LED indicator lights red.

Wait for the Call Allowance tone to end (if activated), then speak clearly into the microphone.

Release the PTT key to answer.

If there is no voice activity for a predetermined time period, the call is terminated.

You will hear a short tone.

6.1.5.6 Receive all-calls

An all-call is a call from one individual intercom to all intercom on the channel. It is used to make important announcements that require special attention from the user.

Process:

When you receive a full call:

A beep sounds and the LED turns green.

If there is no voice activity for a predetermined time period, the all-call is terminated. If the Channel Idle Indication feature is enabled, you will hear a short beep when the transmitter intercom releases the PTT key, indicating that the channel is now available. You cannot reply to a full call.

NOTE: If you switch to another channel while receiving a full call, the intercom stops receiving that full call. During an all-call, you will not be able to use any of the pre-programmed keys until the call ends.

6.1.5.7 Initiate an intercom call

You can select a channel using the following:

- Switch to the corresponding channel by pressing the key Channel+ or Channel-;

6.1.5.7.1 Selecting a Channel to Initiate a Call Using the Channel+ or Channel- Buttons

6.1.5.7.2 Initiating a Group Call

To initiate a call to a user group, the intercom must be configured to belong to that talkgroup.

Process:

1) Turn the channel selector knob to select a channel using the active talkgroup ID.

- 2) Hold the intercom in a vertical position and 1 to 2 inches (2.5 to 5.0 cm) from your mouth.
- 3) Press the PTT key to initiate a call. The LED indicator lights red.
- 4) Wait for the Call Allowance tone to end (if activated), then speak clearly into the microphone.
- 5) Release the PTT key to answer. When the target intercom replies, the LED lights green.
- 6) If the Channel Idle Indication feature is enabled, when the target intercom releases the PTT key, you will hear a short

A beep on the phone indicates that the channel is free and waiting for you to answer. Press the Talk button (PTT) to answer. Or if you are on a scheduled

The call is terminated if there is no voice activity during the interval period.

Low battery alarm function

Users can keep abreast of battery power usage.

Red LED flashes to indicate when the battery is low.

6.1.7 TOT function

When the user has configured a valid TOT time in the Write Frequency parameter, the intercom will immediately stop transmitting and prompt the user to enter the TOT forbidden state when the user transmits more than the accumulated TOT time.

Timeout: You can set the maximum time that the intercom is allowed to transmit continuously. When the predetermined timer expires, the intercom sounds a warning tone and stops transmitting.

Range: (0 off) 0-360 seconds

Step value: 10 seconds

Default: 60 seconds

Timeout Pre-Warning Time: Allows you to set how long before the timeout timer (TOT) expires, the intercom will sound a "warning tone". When the specified time has elapsed since the tone was sounded, the TOT timer will expire.

Range: Off (0)/1-60 seconds

Step value: 1 second

Default value: 0 (0 means off)

TOT Rekey Time: You can set the time from the start of the TOT to the time when it is allowed to fire again. When this time has not expired, pressing the PTT will result in an audible warning that the transmitter is not allowed to transmit.

Range: Off (0)/1-60 seconds

Step value: 1 second

Default value: 0 (0 means off)

Timeout Disable Reset Time: Before the TOT time is reached, the timer will continue to count if it has been fired during the TOT reset time; otherwise, the timeout counter will start counting from 0.

Range: Off (0)/1-60 seconds

Step value: 1 second

Default value: 0 (0 means off)

parameterization

6.2.1 Setting the power level

You can set the intercom power level to high or low for each channel.

Setup: High power to enable communication with relatively distant radios. Low power enables communication with radios that are closer.

Process:

- 1) Switch between high and low power by long-pressing the Channel-Button;
- 2) When switching to high power you will hear a "tic" tone indicating that the intercom is transmitting at low power. When switching to low power you will hear 2 "tilting" beeps indicates that the intercom is transmitting at low power.

6.2.2 CTCSS Functions

1. Set the transmit CTCSS code and receive CTCSS code in the channel parameters by writing frequency software
2. A walkie-talkie can only receive signals that match the set receive CTCSS code when the receive CTCSS code is set, but the walkie-talkie can receive any signal that matches the receive frequency when the receive CTCSS code is not set.
3. The intercom will emit the appropriate CTCSS code when transmitting after setting the transmit CTCSS code.

6.2.3 CDCSS Functions

1. The transmit CDCSS code and receive CDCSS code are set in the channel parameters by the frequency writing software.
2. The intercom can only receive signals that are consistent with the set receive CDCSS code when the intercom is set to receive CDCSS codes, but the intercom can receive any signal that is the same as the receive frequency when the intercom is not set to receive CDCSS codes.
3. When the intercom is set to transmit a CDCSS code, it will emit the corresponding CDCSS code when transmitting.

Tone Cancellation. To avoid a tail tone from the receiver when the carrier disappears on a channel. When the carrier disappears at the end of the message transmission, the receiver is prompted by the

This is not detected instantly and a harsh noise is emitted. When the signal with subaudio transmission is finished, the sender will continue to send a special signal.

A defined signal prompts the receiver so that the receiver can turn on squelch before the carrier disappears.

Chapter 7: Complete machine testing

7.1 Required test equipment

1. Stabilization of power supply

- 1) The output power supply is adjustable between 3.6V and 12V and has a current of 3A or greater.
- 2) The standard voltage is 3.7 V.

2. Ammeter

- 1) Advanced ammeter (17 speeds and other functions).
- 2) The full scale can be set to 300mA or 3A.
- 3) Low-loss cables must be used.

3. Digital voltmeter

- 1) Voltage range: approximately FS = 18V.
- 2) Input impedance value: 1M Ω or greater.

4. oscillograph

- 1) Measurement range: DC to 30 MHZ.
- 2) Provides highly accurate measurements between 5 and 25 MHz.

5. Spectrum analyzer

Measurement range: DC to 1 GHz or greater

6. False loads

16 Ω , 3W or higher

7. Integrated tester

8920a/8921A/8920b/3920

Table 1 List of adjustment frequencies

(radio) band	UHF (400-480MHz)	
signal path	Transmission frequency (MHz)	Receiving frequency (MHz)
CH:0	400.000	400.000
CH:1	417. 500	417. 500
CH:2	435.000	435.000
CH:3	452. 500	452. 500
CH:4	470.000	470.000

Table 2 List of adjustments to QT

frequency band	UHF (400-480MHz)	
signaling number	QT frequency (broadband)	QT frequency (narrowband)
0	67 Hz	67 Hz
1	127.3 Hz	114.8 Hz
2	136.5 Hz	136.5 Hz
3	206.5 Hz	206.5 Hz
4	241.8 Hz	241.8 Hz

Remarks:

- Connect the handheld to a computer.
- Sends channel data to the handheld and then backs up the data.
- Program the adjusted frequency from the list into the handheld.

Note: After making adjustments, reload the backup channel data.

7.2 Debugging Instructions**Table 3 Launch section****Table 4 Receiving section**

General part	
frequency range	UHF:400-480MHz
Number of conventional channels	32CH (2 areas of 16 channels each)
channel spacing	Analog: 12.5KHz/25KHz Digital: 12.5KHz
operating temperature	-30° C~+60 ° C
operating voltage	3.7 VDC
Antenna Impedance	50 Ω
Microphone Impedance	2.2K Ω
battery capacity	Li-ion DC3.7V 1800mAh
Volume (L*W*T)	138.6mm*46mm*23.3mm
weights	115g (main unit only) (main unit with battery and antenna)
Reception indicators	
Sensitivity (12dB SINAD)	25K ≧ -121dBm 12.5K ≧ -119dBm
signal-to-noise ratio	25K ≧ 45 dB 12.5K ≧ 40 dB
Neighborhood selectivity	25K ≧ 65 dB 12.5K ≧ 60 dB
intermodulation immunity	25K ≧ 60 dB 12.5K ≧ 55 dB
false response	≧ 65 dB
Audio Output Power	≧ 1000 mW
Sensitivity Digital	0.3 μ V/BER5%
audio distortion	≧ 5%
frequency stability	± 2.5ppm
standby time	42 hours (battery capacity 1800mAh)
launching section	
RF power	H: 1.5 W L: 0.5 W
modulation method	25k/16k Φ f3e 12.5k/8k Φ f3e
4FSK digital modulation	12.5KHZ Data 7K60FXD 12.5KHZ Data and Voice 7K60FXW
Digital Voice Encoder	AMBE++
digital protocols	ETSI-TS102 361-1,-2
Clutter and harmonics	≧ 70 dB
residual FM	25K ≧ -45 dB 12.5K ≧ -40 dB
audio distortion	≧ 5%
frequency stability	± 2.5 ppm
Maximum frequency deviation	25K ≧ 5 kHz 12.5K ≧ 2.5 kHz

RF power	H: 1.5 W L: 0.5 W
modulation method	25k/16k Φ f3e 12.5k/8k Φ f3e
4FSK digital modulation	12.5KHZ Data 7K60FXD 12.5KHZ Data and Voice 7K60FXW
Digital voice encoder	AMBE++
digital protocols	ETSI-TS102 361-1,-2
Clutter and harmonics	\cong 70 dB
residual FM	25K \cong -45 dB 12.5K \cong -40 dB
audio distortion	\cong 5%
frequency stability	\pm 2.5 ppm
Maximum frequency deviation	25K \cong 5 kHz 12.5K \cong 2.5 kHz

Chapter9. Specifications

Frequency range	UHF: 400-480 MHz
RF Power Output	1.5W/0.5W
Number of channels	32 channels
Operating voltage	3.7V DC \pm 0.1
Temperature range	-30 $^{\circ}$ C ~ +60 $^{\circ}$ C (-22 $^{\circ}$ F to +140 $^{\circ}$ F)
Volume (length \times width \times height)	138.6mm*46mm*23.3mm
Weight	Approx. 115 (main unit with battery and antenna)
Batteries	Lithium Battery Li-ion DC3.7 V 1800mAh