





Consumo de energía máximo (a través de PoE)

modelo	vatios	Voltaje	Amperios
FD839-EHV	12.3	37 ~ 57	0,33 ~ 0,21
FD839-EHTV	12.3	37 ~ 57	0,33 ~ 0,21

4

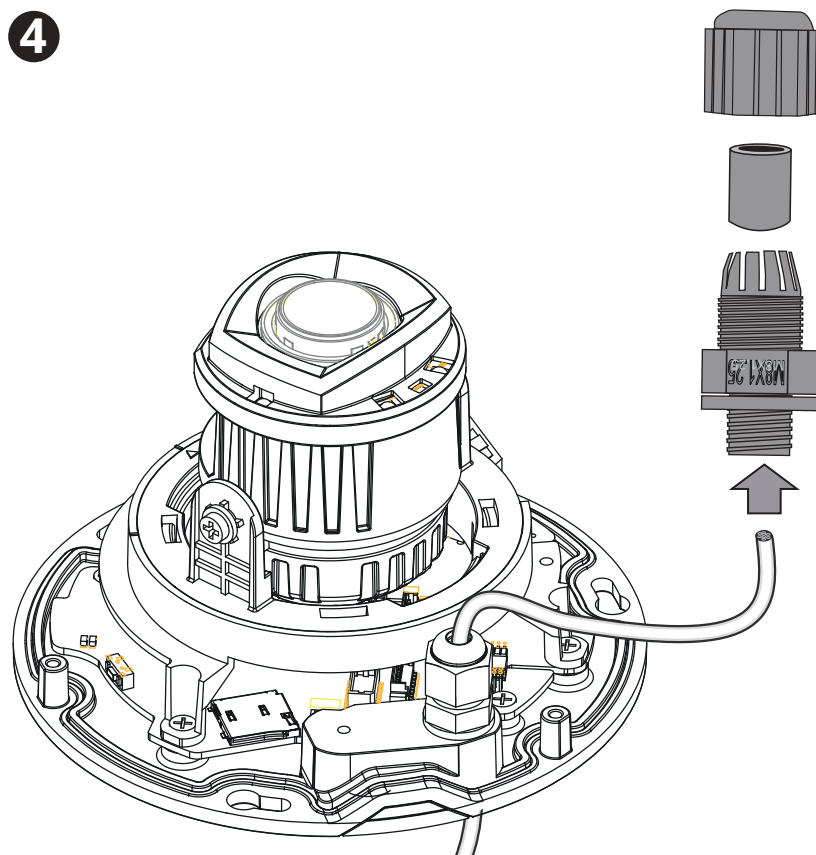

5

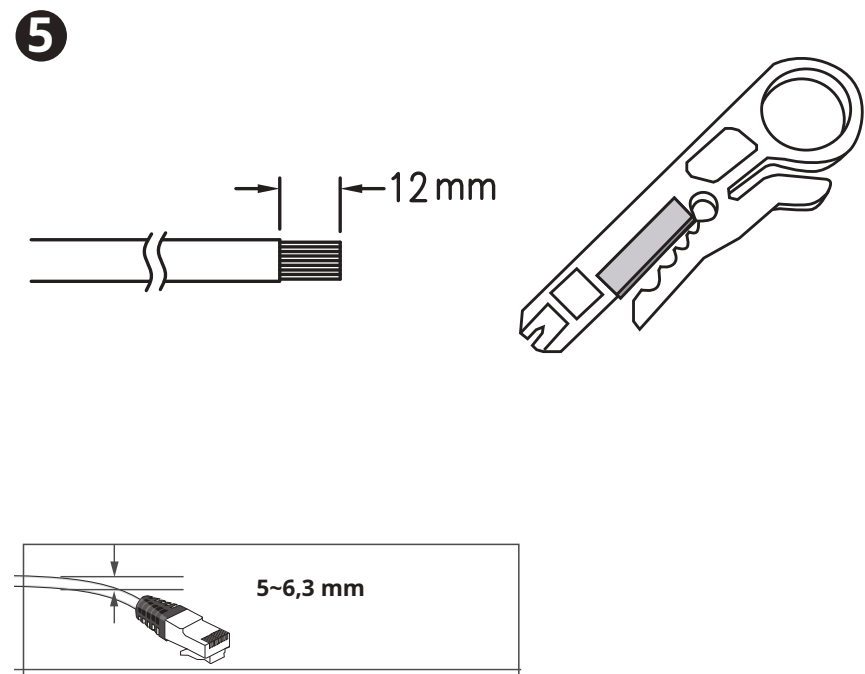

6

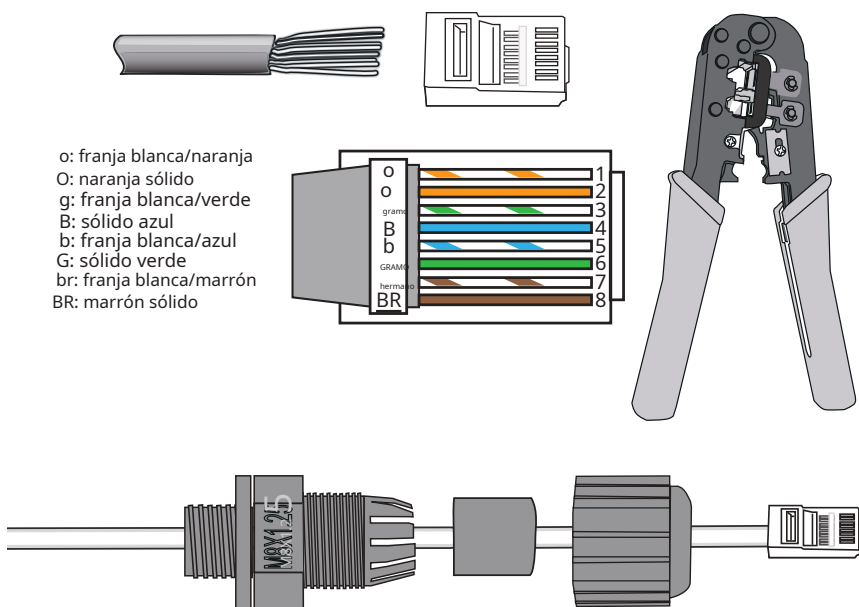

o: franja blanca/naranja  
 O: naranja sólido  
 g: franja blanca/verde  
 B: sólido azul  
 b: franja blanca/azul  
 G: sólido verde  
 br: franja blanca/marrón  
 BR: marrón sólido

7

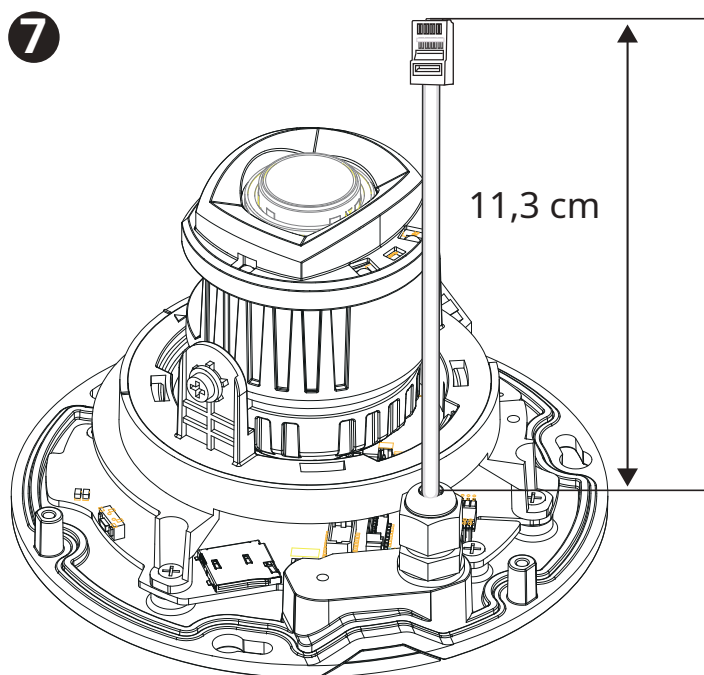

8

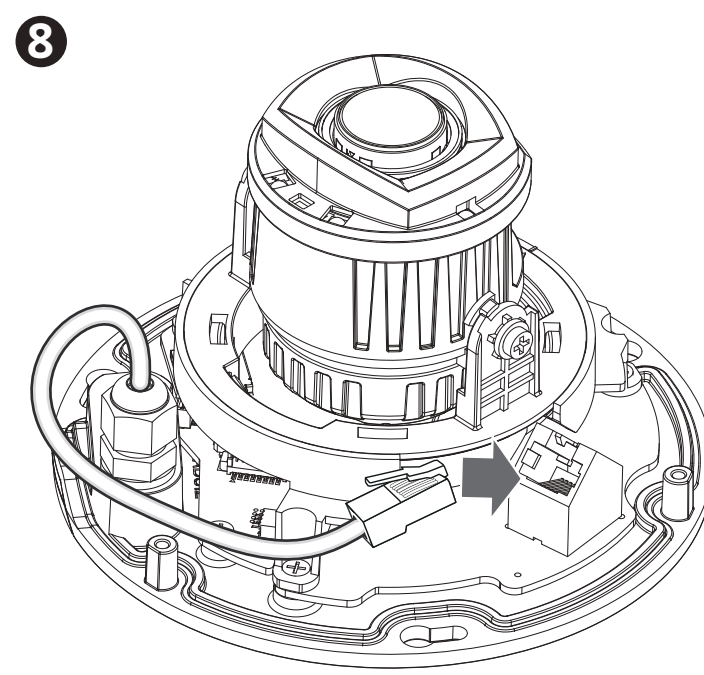

9

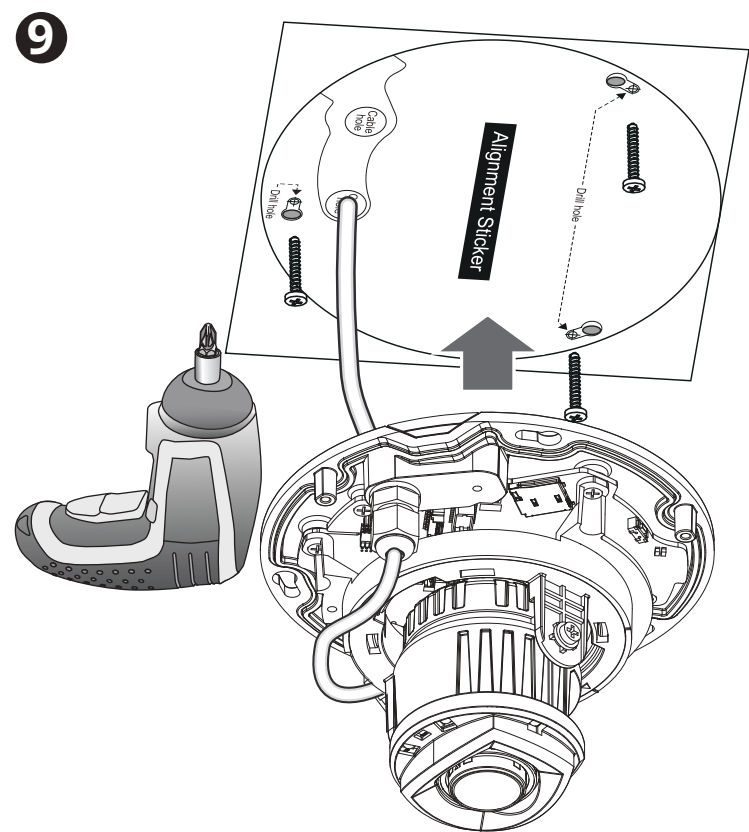

10 Escanee el código QR a continuación para descargar la aplicación Vortex.

Código QR de iOS



Código QR de Android



11 Crea una cuenta Vórtice.



- 0 -

12 Inicie sesión en la aplicación Vortex.

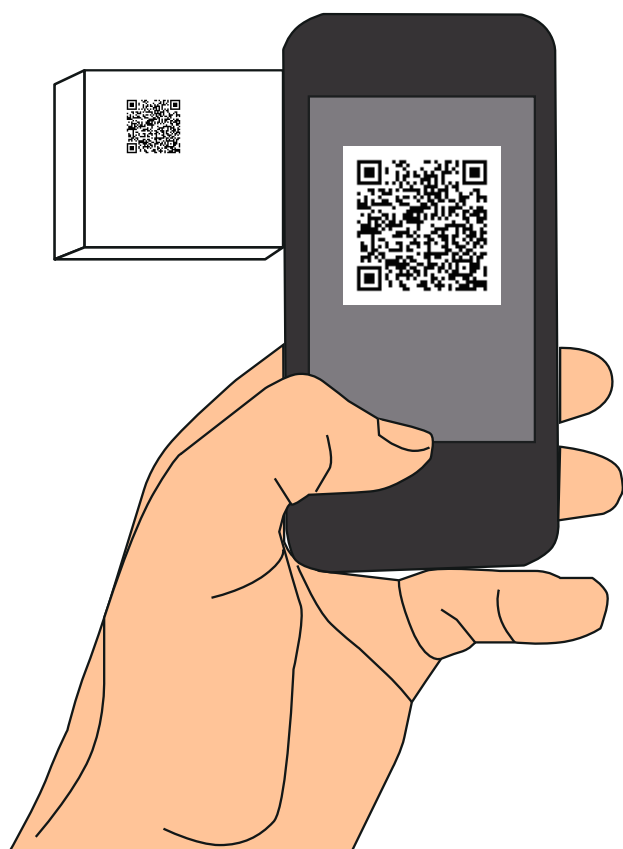
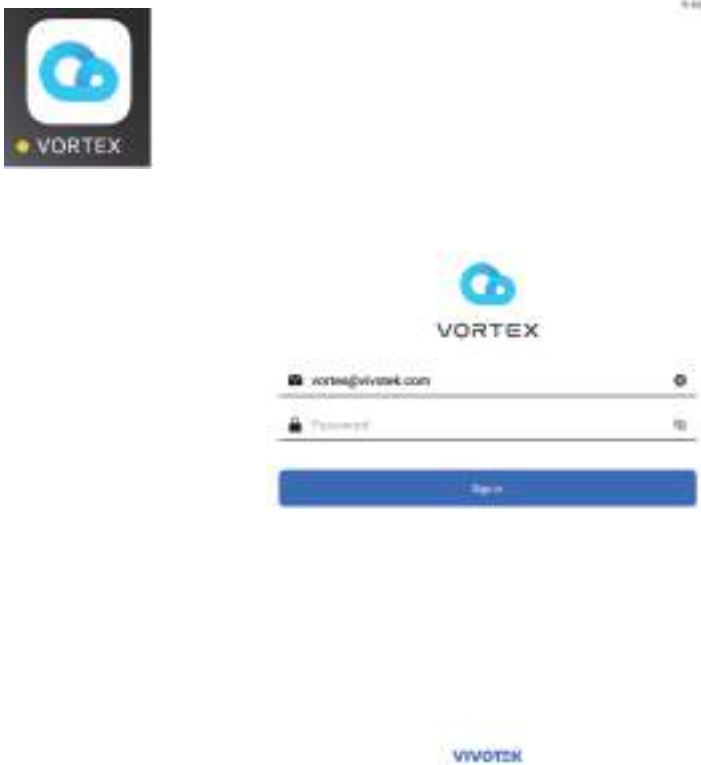

13 Agrega tu cámara.



15 Escaneo exitoso.



14 Escanee el código QR en la caja o en la cámara.

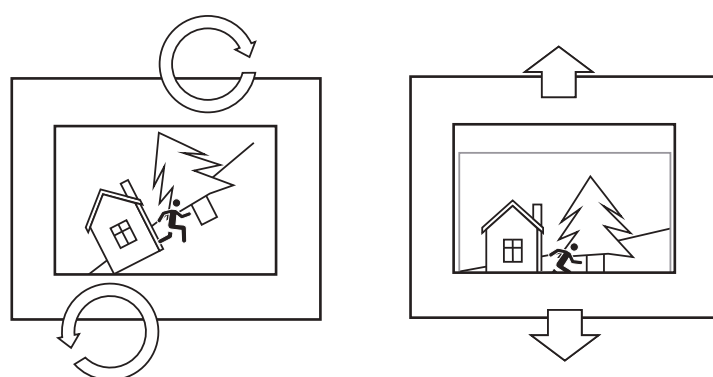
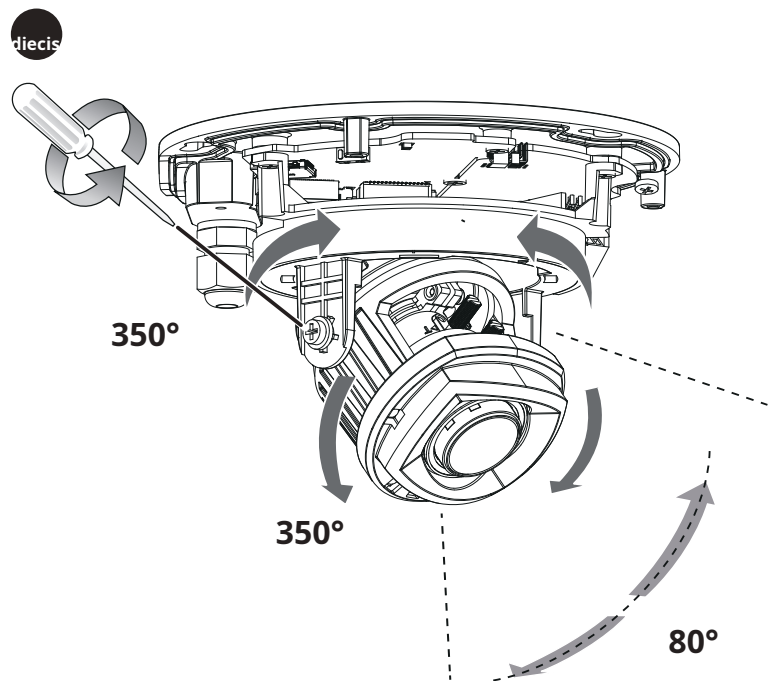
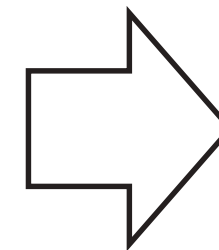



-EHTV

<https://www.vivotek.com/#/iniciar sesión>

Dispositivo > Configuración > Imagen > Ajuste de enfoque

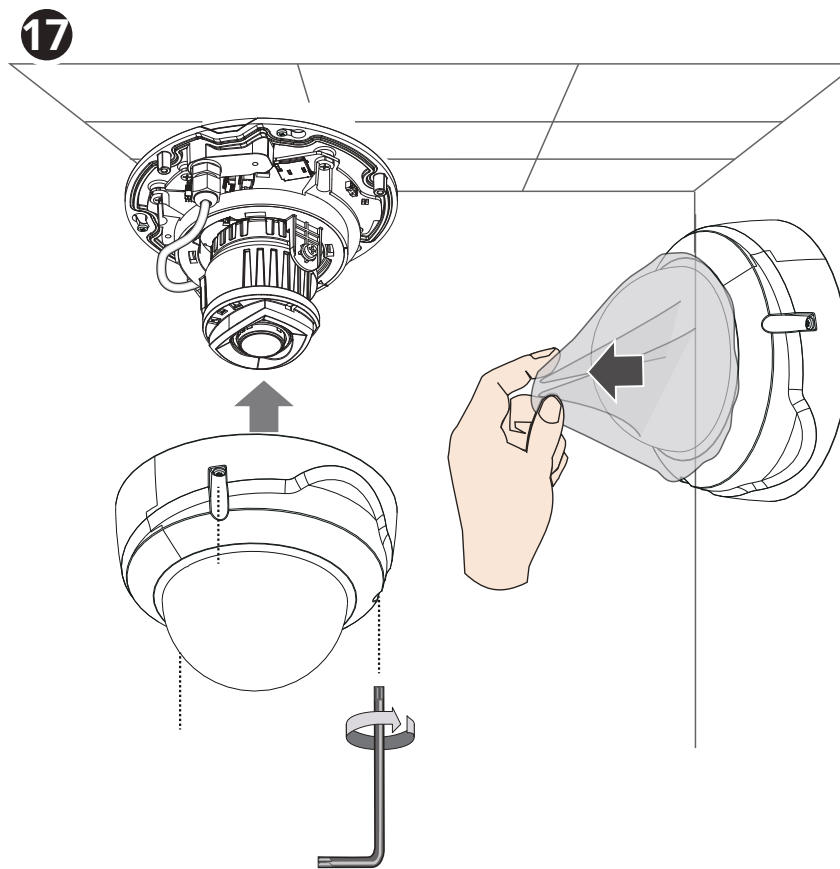
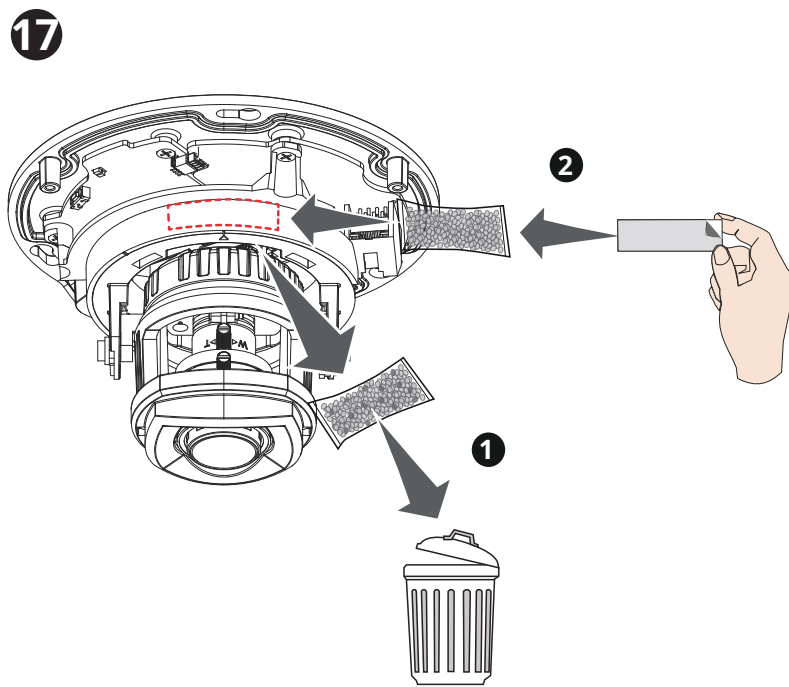
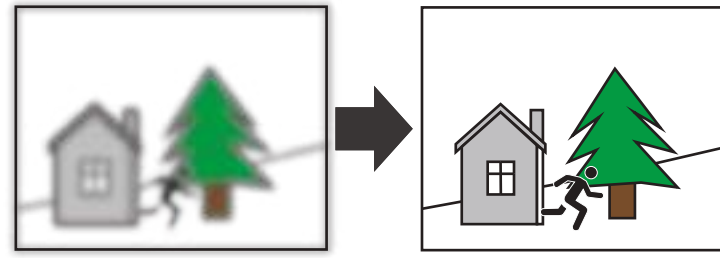
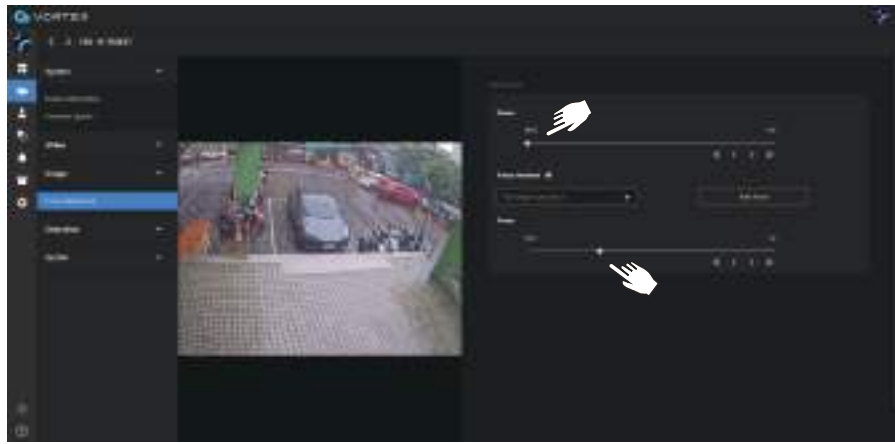

Si utiliza la detección de movimiento inteligente

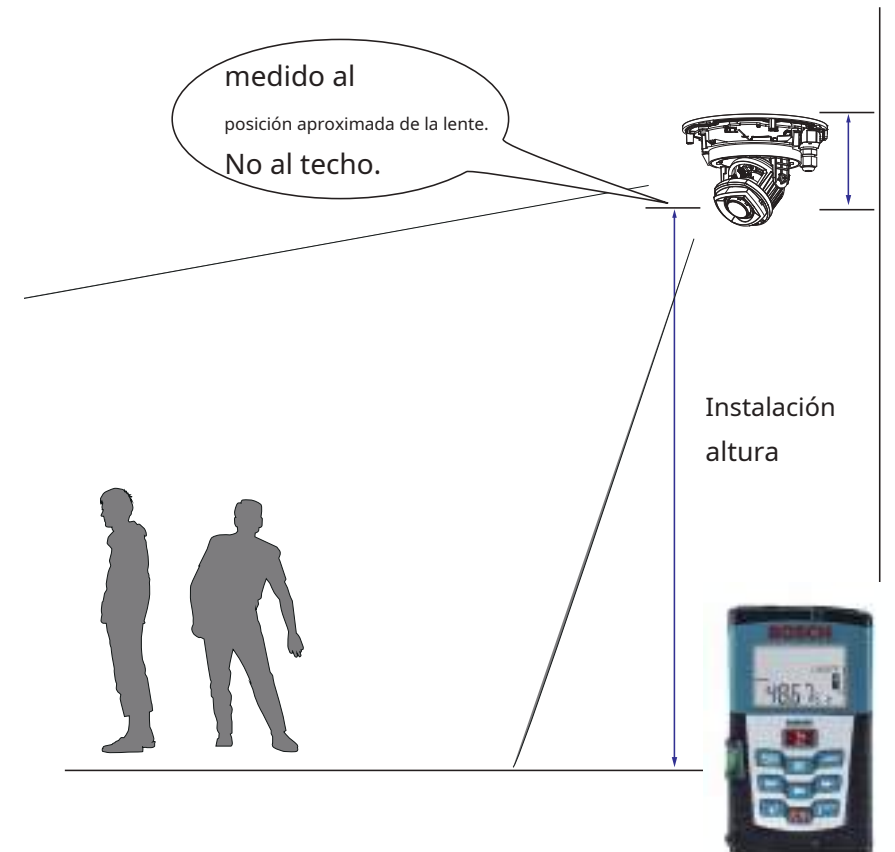

**VIVOTEK**  
A Delta Group Company

Comuníquese con los distribuidores autorizados para la garantía y el servicio RMA.  
Visite <https://www.vivotek.com/support/warranty-rma>

Todas las especificaciones están sujetas a cambios sin ruido.  
Copyright © 2022 VIVOTEK INC. Todos los derechos reservados.

VIVOTEK INC.  
6F, No.192, Lien-Cheng Rd., Chung-Ho, Nueva Ciudad de Taipei, 235, Taiwán, República de China  
|T: +886-2-82455282| F: +886-2-8245532| M: sales@vivotek.com

VIVOTEK USA, INC.  
2050 Ringwood Avenue, San José, CA 95131  
|T: 408-773-8686| F: 408-773-8298| M: salesusa@vivotek.com

VIVOTEK Europa  
Zandsteeen 15, 2132 MZ Hoofddorp Delta Electronics  
T: +31 (0)20 800 3817 E: saleseurope@vivotek.com