

USER MANUAL

Optical Fiber Fusion Splicer

LP-FS-PRO-X6

PLEASE READ THIS INSTRUCTION MANUAL CAREFULLY BEFORE
OPERATING THE EQUIPMENT.

ADHERE TO ALL SAFETY INSTRUCTIONS AND WARNINGS
CONTAINED IN THIS MANUAL.

KEEP THIS MANUAL IN A SAFE PLACE.

About This Manual

Thank you for purchasing Linkedpro product. Please read this manual carefully before using any of Linkedpro products. Always observe the warnings and cautions appearing throughout this manual.

This manual contains the information necessary for proper operation and maintenance of Linkedpro LP-FS-PRO-X6 Optical Fiber Fusion Splicer, troubleshooting instructions as well as information regarding obtaining services.

Linkedpro LP-FS-PRO-X6 Optical Fiber Fusion Splicer is carefully assembled and undergoes a rigorous mechanical, electrical, and optical inspection prior to shipment. For detailed packing information, please refer to the packing list. Upon receiving the instrument, please check for any obvious signs of physical damage that may have occurred during shipment. Report any damage to the shipping agent or the representative of Linkedpro immediately. Retain the original packing materials in case reshipment becomes necessary.

A

The splicer has been designed for splicing Silica-based optical fibers for telecommunications. Do not attempt to use this machine for other applications. Linkedpro gives much consideration and regard to personal injury. Misuse of the machine may result in electric shock, fire and/or serious personal injury.

Follow all safety instructions

Read and understand all safety instructions

Stop using it when it malfunctions

Ask our service centers for repair as soon as possible.

Instruction Manual

Read this instruction manual carefully before operating this machine. Store this instruction manual in a safe place

Notices

Copyright©, Linkedpro, All rights reserved.

No part of this manual may be reproduced in any form or by any means (including electronic storage and retrieval or translation into a foreign language) without prior agreement and written consent from Linkedpro as governed by international copyright laws.

Warranty

The material contained in this document is subject to change without notice. Linkedpro makes no warranty of any kind with regard to this material, including, but not limited to, the implied warranties of merchantability and fitness for a particular purpose. Linkedpro shall not be liable for errors contained herein or for incidental or consequential damages in connection with furnishing, performance, or use of this material.

The battery is a consumable part and is not subject to the warranty.

B

Safety Instructions

During each stage of operation of this instrument, please always observe the following safety instructions. Not taking any safety precautions or following the instructions will violate the safety standards of design, manufacturing and application of these instruments. In no case will Linkedpro bear the responsibilities for consequences incurred by violation of the following instructions.

General

This product is a Safety Class 3 instrument. The protective features of this product may be impaired if it is used in a manner not specified in the operation instrument.

Environmental Conditions

It is designed to operate at a maximum relative humidity of 95% and at altitudes of up to 5000 meters. For more details, please refer to the specification tables.

Before Applying Power

Verify that the product is set to match the available line voltage, the correct fuse is installed, and all safety precautions are taken. Note the instrument's external markings described under Symbols.

Do Not Operate in an Explosive Atmosphere

Do not operate the instrument in the presence of flammable gases or fumes.

Do Not Remove the Instrument Cover

Operating personnel must not remove instrument covers. Component replacement and internal adjustments must be made only by qualified service personnel.

Safety Terms Used in This Manual

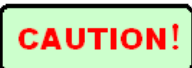
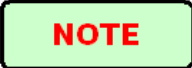
	The WARNING sign denotes a hazard. It calls attention to a procedure, practice, or the like, which, if not correctly performed or adhered to, could result in personnel injury. Do not proceed beyond a WARNING sign until the indicated conditions are fully understood and met.
	The CAUTION sign denotes a hazard. It calls attention to an operating procedure, or the like, which, if not correctly performed or adhered to, could result in damage to or destruction of part or the entire product. Do not precede beyond a CAUTION sign until the indicated conditions are fully understood and met.
	The NOTE sign information that may be beneficial during the use and maintenance of the instrument.

<p>LP-FS-PRO-X6 has been designed for splicing Silica-based optical fibers for telecommunications. Do not attempt to use this machine for other applications. Linkedpro gives much consideration and regard to personal injury. Misuse of the machine may result in electric shock, fire and/or serious personal injury.</p> <ul style="list-style-type: none">a) Follow all safety instructions.b) Stop using it when it malfunctions and ask our service centers for repair as soon as possible.c) Read this instruction manual carefully before operating this machine.
<p>Disconnect the AC power cord from the AC adapter inlet or the wall socket (outlet) immediately if user observes the following or if the splicer receives the</p>

Warning and Caution

following faults:

- a) Fumes, bad smell, noise, or over-heat occurs.
- b) Liquid or foreign matter falls into cabinet.
- c) Splicer is damaged or dropped.

If this occurs, ask our service center for repair. Leaving the splicer in a damaged state may cause equipment failure, electric shock or fire and may result in personal injury, death or fire.

Use only the AC adapter / battery charger designed for this splicer. Using an improper AC power source may cause fuming, electric shock or equipment damage and may result in personal injury, death or fire.

Do not disassemble or modify the splicer, AC adapter or battery. In particular, do not remove or bypass any electrical or mechanical device (e.g. a fuse or safety switch) incorporated into the design and manufacturing of this equipment. Modification could cause damage that may result in personal injury, death, electric shock or fire.

Never operate the splicer in an environment where flammable liquids or vapors exist. Risk of dangerous fire or explosion could result from the splicer's electrical arc in such an environment.

Do not use compressed gas or canned air to clean the splicer. They may contain flammable materials that could ignite during the electrical discharge.

Do not touch the electrodes when the splicer is on and power is supplied to the unit. The electrodes generate high voltage and high temperatures that may cause a severe shock or burn.

NOTE: Arc discharge stops when wind protector is opened.

Turn the splicer off and disconnect the AC power cord before replacing electrodes.

Safety glasses should always be worn during fiber preparation and splicing

Warning and Caution

operation. Fiber fragments can be extremely dangerous if it comes into contact with the eye, skin, or is ingested.

Use only proper power source.

- a) Check the AC power source before use: Proper AC power source is AC100-240V, 50-60Hz. Proper DC power source is DC10-12V. Improper AC or DC power source may cause fuming, electric shock or equipment damage and may result in personal injury, death or fire;
- b) AC generators commonly produce abnormally high AC output voltage or irregular frequencies. Measure the output AC voltage with a circuit tester before connecting the AC power cord. Such abnormally high voltage or frequency from a generator may cause fuming, electric shock or equipment damage and may result in personal injury, death or fire. Make sure the generator is regularly checked and serviced.

Do not modify, abuse, heat or excessively pull on the supplied AC cord. The use of a damaged cord may cause fuming, electric shock or equipment damage and may result in personal injury, death or fire.

LP-FS-PRO-X6 uses a three-prong (core) AC cord that contains an earthed ground safety mechanism. The splicer **MUST** be grounded. Use only the supplied three-prong (core) AC power cord. **NEVER** use a two-prong (core) power cord, extension cable or plug.

Connect AC power cord properly to the splicer (inlet) and wall socket (outlet). When inserting the AC plug, make sure there is no dust or dirt on the terminals. Engage by pressing the female plug into the splicer (inlet) and the male plug into the wall socket (outlet) until both plugs are fully seated. Incomplete engagement may cause fuming, electric shock or equipment damage and may result in personal injury, death or fire.

Do not short-circuit the terminals of AC adapter and optional battery. Excessive electrical current may cause personal injury due to fumes, electric shock and

Warning and Caution

equipment damage.

Do not touch the splicer, AC power cord and AC plugs with wet hands. This may result in electric shock.

Do not operate splicer near hot objects, in hot temperature environments, in dusty/humid atmospheres or when water-condensation is present on the splicer. This may result in electric shock, splicer malfunction or poor splicing performance.

When using Li-ion battery, follow the instructions below. Failure to follow these may result in explosion or personal injury.

- a) Do not charge battery with other methods than instructed.
- b) Do not discard battery into an incinerator or fire.
- c) Do not charge or discharge battery near a flame or under direct sunlight.
- d) Do not excessively shake or jar the battery.
- e) If battery leaks of liquid residue, be careful handling the battery so the liquid does not get in skin or eye contact. If it reaches contact, immediately wash skin or eyes thoroughly and see the doctor. Dispose of the battery and call the service center for replacement.
- f) If charge did not complete in four hours or the "CHARGE" LED is constantly on, immediately stop charging and call the service center for repair.

CAUTION!

Do not store splicer in any area where temperature and humidity are extremely high. Possible equipment failure may result.

Do not touch protection sleeve or tube-heater during heating or immediately after completion of heating. Their surfaces are very hot and touching these may result in skin burn.

Warning and Caution

Do not place the splicer in an unstable or unbalanced position. The splicer may shift or lose balance, causing the unit to fall. Possible personal injury or equipment damage may result.

The splicer is precision adjusted and aligned. Do not allow the unit to receive a strong shock or impact. Possible equipment failure may result. Use supplied carrying case for transportation and storage. The carrying case protects the splicer from damage, moisture, vibration and shock during storage and transportation.

Follow the below listed instructions for handling electrodes.

- a) Use only specified electrodes.
- b) Set the new electrodes in the correct position.
- c) Replace the electrodes as a pair.

Failure to follow the above instructions may cause abnormal arc discharge. It can result in equipment damage or degradation in splicing performance.

Do not use any chemical other than pure alcohol (99% or greater) to clean the objective lens, V-groove, mirror, LCD monitor, etc., of the splicer. Otherwise blurring, discoloration, damage or deterioration may result.

The splicer requires no lubrication. Oil or grease may degrade the splicing performance and damage the splicer.

The equipment must be repaired or adjusted by a qualified technician or engineer. Incorrect repair may cause fire or electric shock. Should any problems arise, please contact your nearest sales agency.

SUBJECTS

Introduction	1
➤ Product unpacking inspection	1
➤ Description of Products.....	2
Description of Products.....	3
1. Components of Splicer	3
➤ Our Splicer	3
2. Description and Function of Splicer	4
➤ Top Side of LP-FS-PRO-X6.....	5
➤ Front Side of LP-FS-PRO-X6.....	6
➤ Back Side of LP-FS-PRO-X6.....	6
➤ Keypad of LP-FS-PRO-X6	7
Basic Operation	9
1. About Power	9
➤ Inserting Power Supply into Splicer	9
➤ Battery operation.....	9
2. Turning Splicer "ON"	9
➤ LCD Brightness Adjustment	10
3. Fiber Preparation	11
A. Placing Protection Sleeve over Fiber	11
B. Stripping and Cleaning Fiber.....	11
C. Fiber Cleaving.....	12
4. Loading Fiber to Splicer	12
5. Heating protection sleeve	15
Menu Operation	16
1. Splice Mode Menu	16
➤ Database	17
2. Heater Mode.....	19
3. Splice Set	22
4. Data Save.....	22
5. Set Menu.....	23

Table of Contents

6. Maintenance Menu.....	32
Through "discharge correction", the discharge parameters are adjusted on the spot in real time to optimize the welding result.....	33
Common Problems and Troubleshooting.....	39
Warranty Information	41
1. Terms of Warranty	41
2. Exclusions.....	41
3. Warranty Registration	41
4. Returning Instruments.....	41

Introduction

➤ **Manual Contents**

Thank you for choosing our products. Please read this manual carefully before using any meter, especially the warning and caution information, so as to avoid user injury or instrument damage due to incorrect use.

This manual contains necessary information for proper operation and maintenance of Linkedpro® LP-FS-PRO-X6 series optical fiber splicer, as well as troubleshooting guide and various information for obtaining technical support and service.

Linkedpro® LP-FS-PRO-X6 series optical fiber fusion splicer is a product carefully developed and produced by our company, and has passed strict quality control procedures such as mechanical, electronic and optical inspection before leaving the factory. In the product packaging, along with the instrument, It should also include a data cable, power adapter, and this user manual. See the packing list for details.

When you receive the meter, please check it carefully and discover the physical damage that may be caused during the shipment of the product. If you find any signs of damage, please immediately notify the shipping company and the agent of this product, and save the original packaging materials to If necessary, the problem can be properly solved.

➤ **Product unpacking inspection**

This product is packed in boxes in accordance with standard assembly and freight procedures. After you receive the meter, please check it carefully according to the list in the box. If you find that the materials in the box are not complete, and the product has any signs of physical damage or is not working properly Work, please contact the company's agent responsible for your supply in time to solve it.

➤ **Description of Products**

Linkedpro® LP-FS-PRO-X6 Optical Fiber Fusion Splicer is for fiber fusion with low splice loss and ensures splice long-time stabilization. Splice loss depends on certain conditions like fiber preparation, splicing parameters, fiber condition, variation after splicing and etc.

The standard principle of splicing is not complicated, firstly the splicer finds the fiber core and aligns it correctly, and then it splices the fiber with the arc generated by the electrodes. There are two major technologies to ensure high-quality splice, LID (Local Injection and Detection) and CDS (Core Detection System), which is also widely known as PAS (Profile Alignment System).

LP-FS-PRO-X6 with PAS technology is designed for splicing many types of optical fibers. It is small in size and light in weight, making it suitable for any operating environment. It is easy to operate and it splices fast while maintaining low splice loss. In order to achieve the splicer's full capabilities, read the following important information.

Description of Products

1. Components of Splicer

➤ Our Splicer



2. Description and Function of Splicer

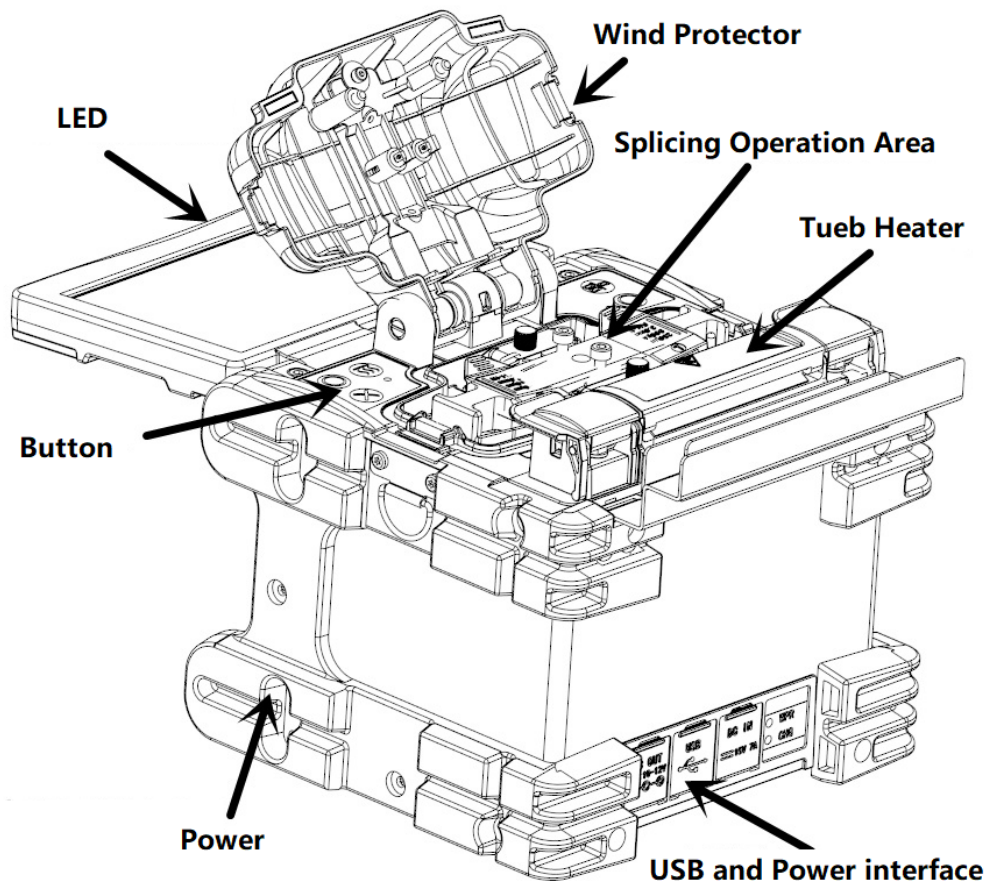

➤ **Top Side of LP-FS-PRO-X6**

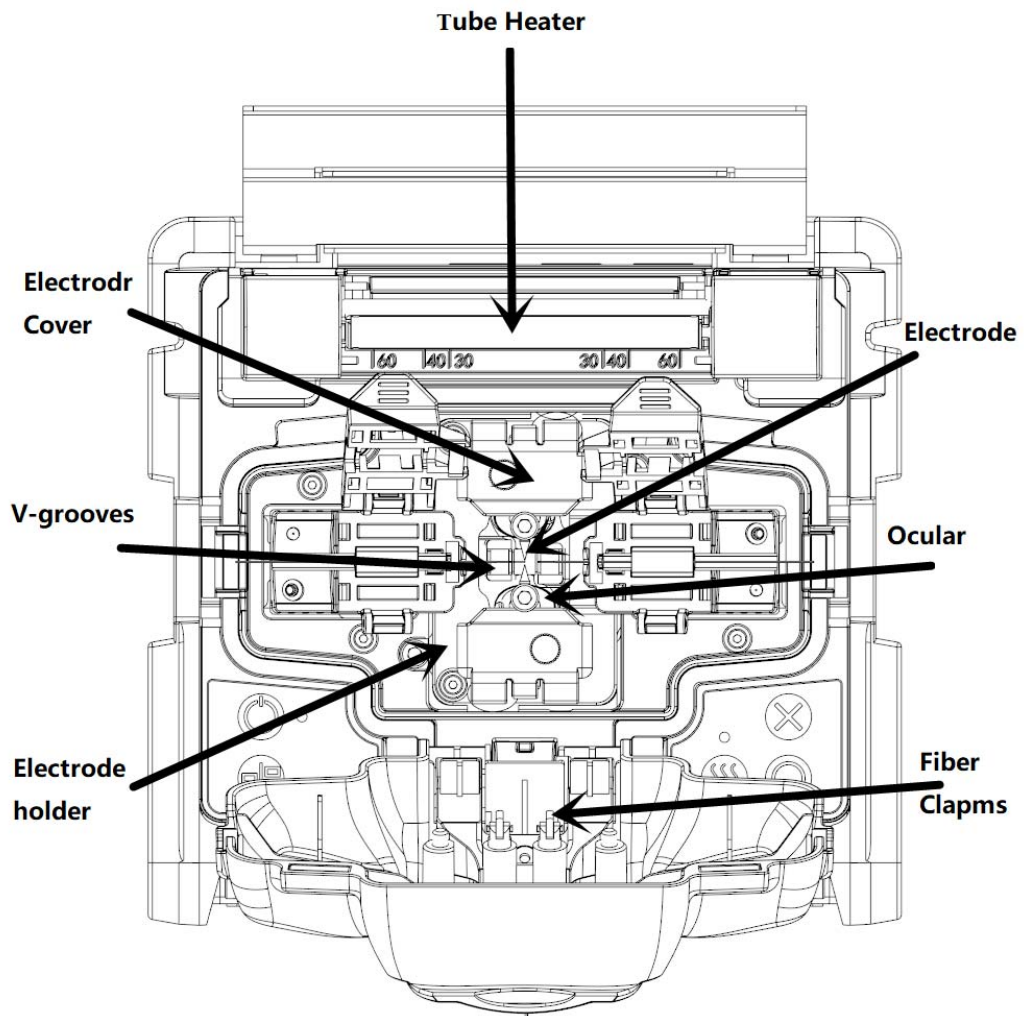

➤ **Front Side of LP-FS-PRO-X6**

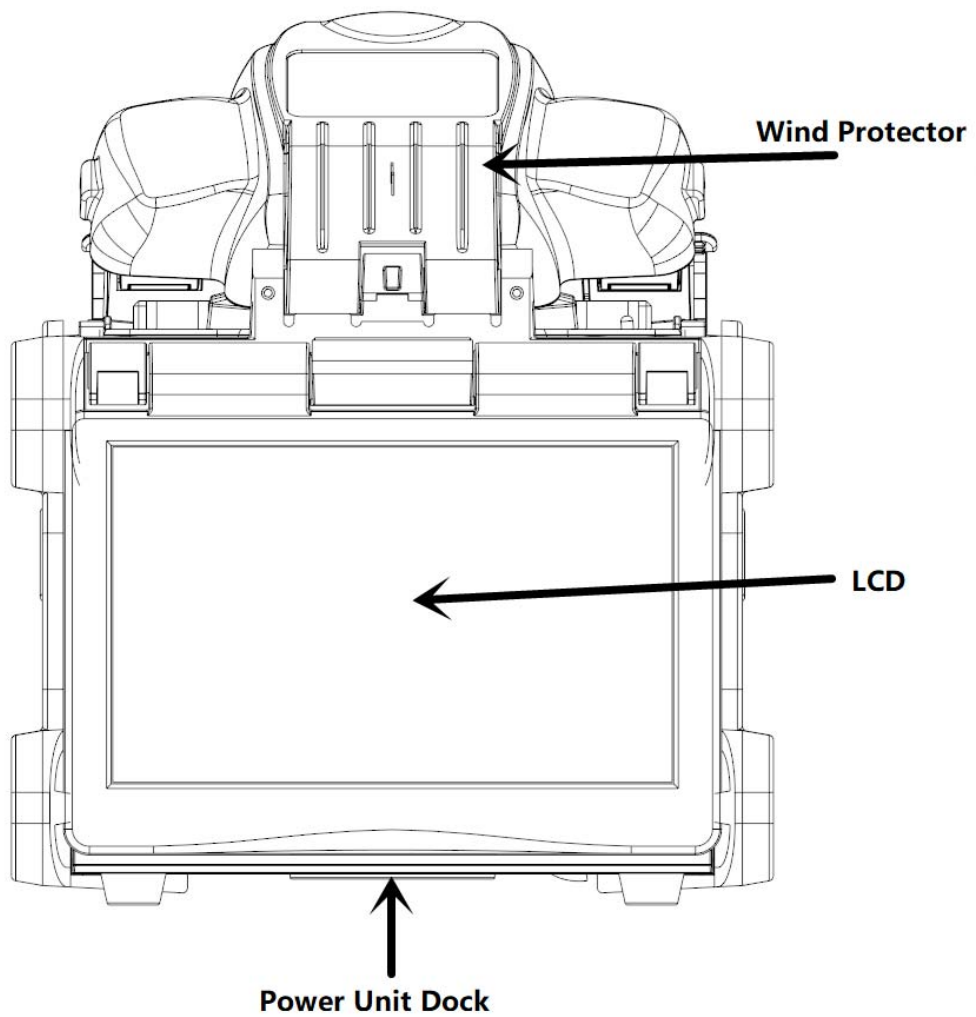

➤ **Back Side of LP-FS-PRO-X6**

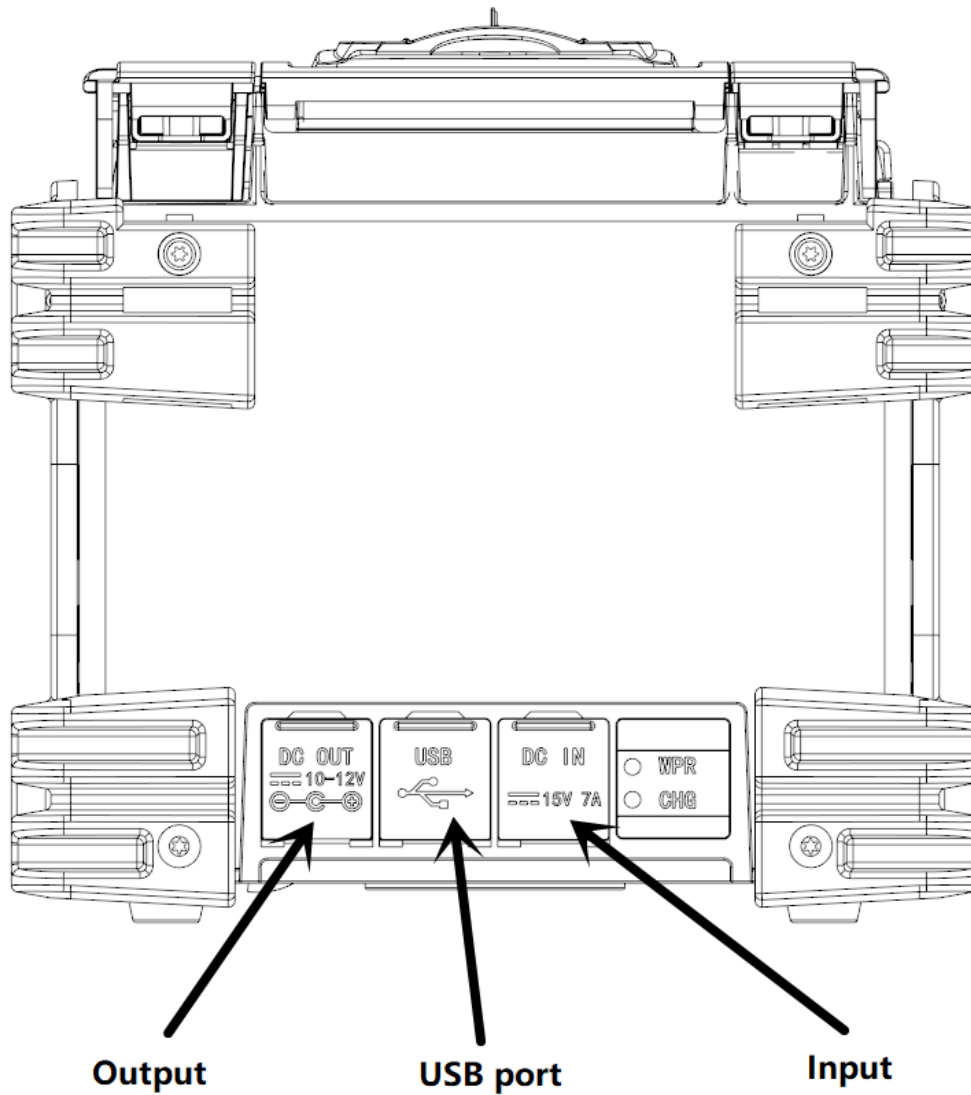









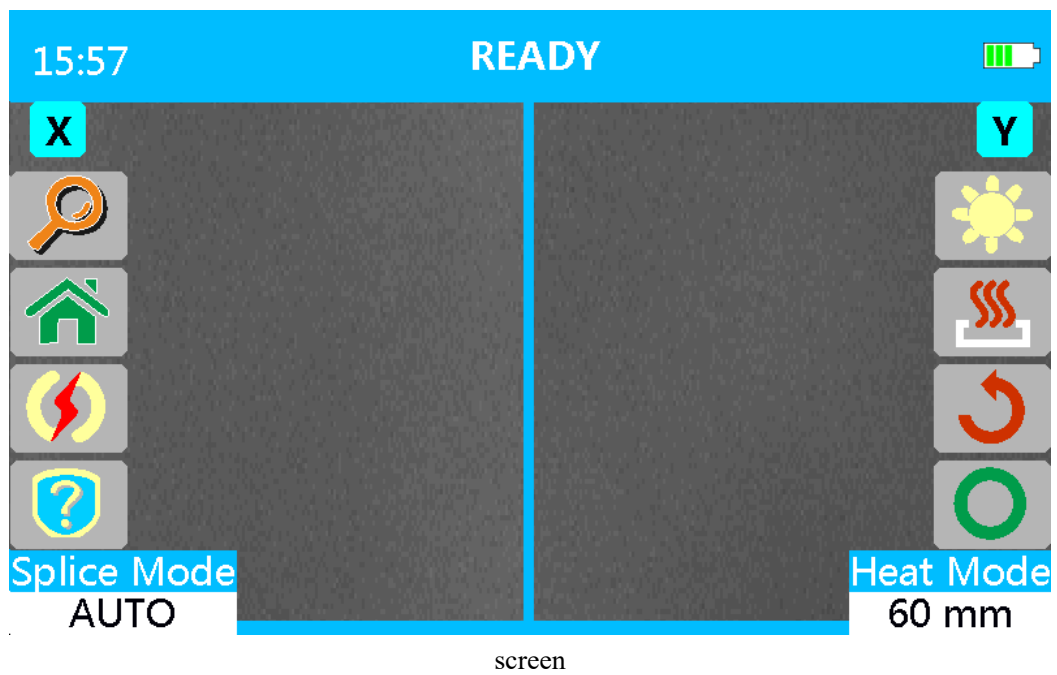

➤ **Keypad of LP-FS-PRO-X6**



Left keypad

Right keypad



	Search		LCD brightness
	Main menu		Heat
	Discharge		Reset
	Help		Splice
			Down
			Up

Basic Operation

1. About Power

➤ **Inserting Power Supply into Splicer**

LP-FS-PRO-X6 can be powered by external power adaptor and power supply unit.

- a) Inserting or detaching power supply unit

Insert power unit into Power unit dock until it clicks into place.

- b) Detaching power supply unit

Turn off the splicer. Push the release button, located on the side of the splicer body, and remove the power supply out of the splice body.

➤ **Battery operation**

Check and make sure the remaining battery capacity is 20% or greater before operation otherwise few splices can be made.

Two ways to check remaining battery capacity:

- a) If battery is already inserted in the splicer, turn splicer ON. Power source of "Battery" is automatically identified and the remaining battery capacity is displayed on the "READY" screen.
- b) Or press battery check button on the battery pack. The remaining battery capacity is indicated on the LED indicator.

2. Turning Splicer "ON"





Press [] and hold it until the green LED on the keypad is "ON". The "READY" screen is displayed after all the motors reset to their initial positions. The power source type is automatically identified. If the battery is

used, the remaining battery capacity is displayed.

➤ LCD Brightness Adjustment

When the external environment changes or is different, the display brightness may not be able to meet specific needs. In the “Ready” interface after splicer is powered on,

press  to enter, press   button to adjust LCD brightness; press execution to confirm.

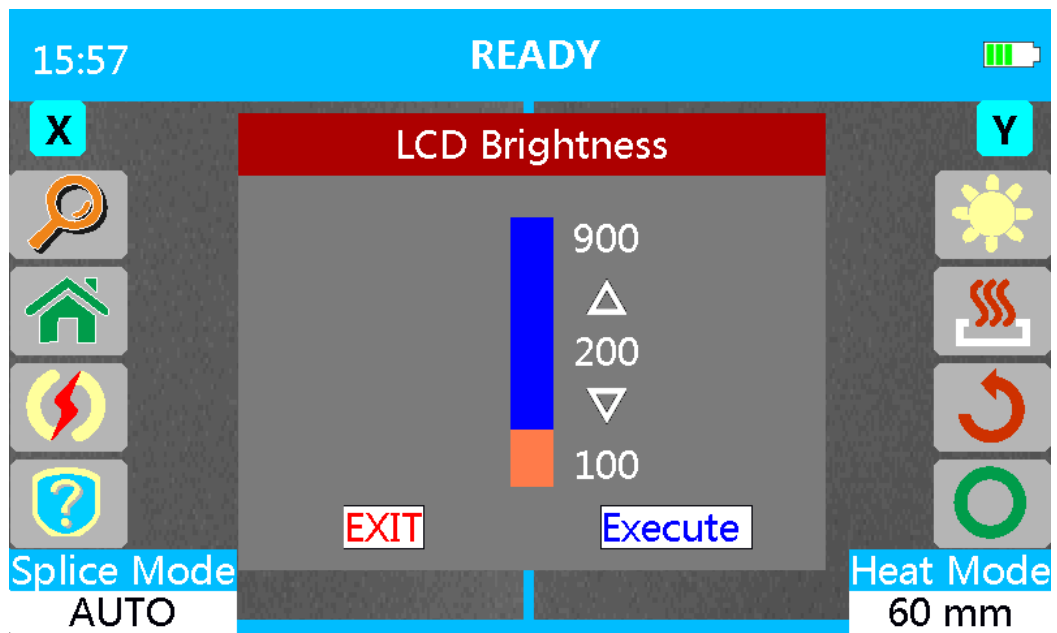

3. Fiber Preparation

A. Placing Protection Sleeve over Fiber

Clean optical fiber with alcohol-impregnated gauze or lint-free tissue approximately 100mm from the tip. Place the protection sleeve over the fiber.

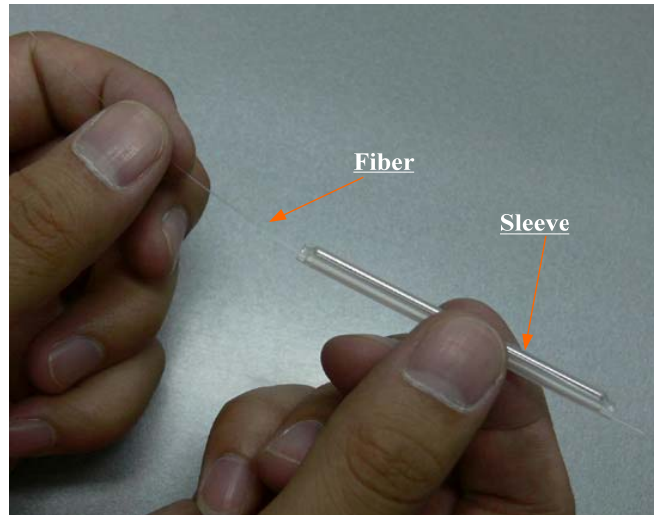

CAUTION!

- Clean optical fiber with alcohol-impregnated gauze or lint-free tissue. Dust particulates can enter inside the protection sleeve and might result in a future fiber break or attenuation increase.
- Make sure fiber is passed into the protection sleeve.
- When protection sleeve core tube is longer than the length of outer sheath, the excess part should be cut off to avoid micro bend after heating.

B. Stripping and Cleaning Fiber

Strip fiber's outer coat 30 to 40 mm from its tip with a stripping tool. Clean the fiber with alcohol (Purity $\geq 99\%$) impregnated gauze or lint-free tissue thoroughly.

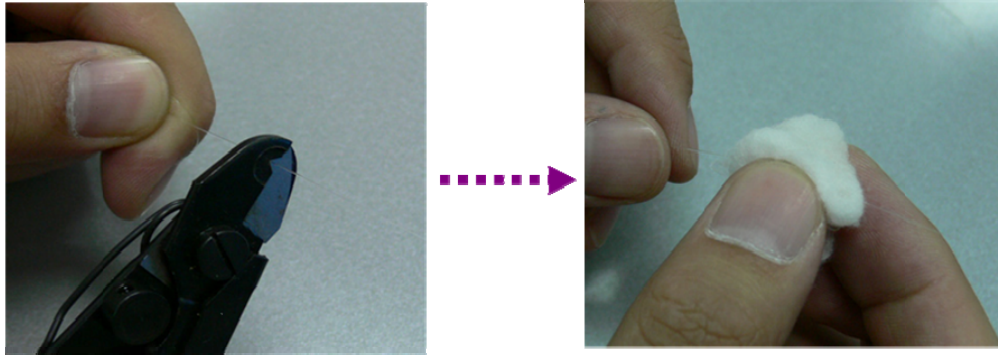

C. Fiber Cleaving

When cutting the fiber, pay attention to the cutting length. The cutting length is 10-16mm. (The cutting length of the coating layer is greater than 250um is 16mm. After cutting, do not let the fiber end-face touch anything to avoid staining the optical fiber.

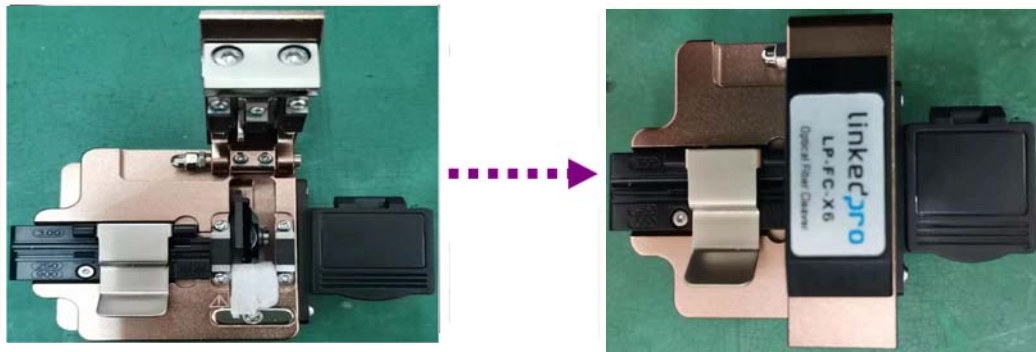

4. Loading Fiber to Splicer

- Open wind protector and sheath clamps.
- Place prepared fiber onto v-groove so that the fiber tip is located between the v-groove edge and tip of electrode.
- Hold fiber with fingers and close sheath clamp so that the fiber does not move. Make sure the fiber is placed in the bottom of the v-grooves. If fiber is not placed properly, reload fiber.



- d) Load another fiber in the same manner as in above step.
- e) Close wind protector.

CAUTION!

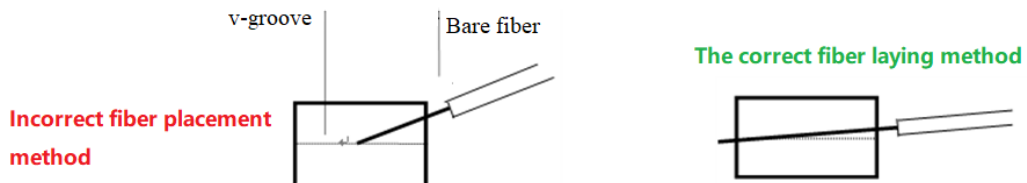

To assure a good splice, the optical fiber is observed with the image processing system equipped in the LP-FS-PRO-X6. However, there are some cases when the image processing system cannot detect a faulty splice. Visual inspection with the monitor is often necessary for better splicing yield. Procedure below describes standard operating procedure.

- a) After fibers are loaded in the splicer, press  button and fibers move forward toward each other. The fiber forwarding motion stops at a certain position shortly after the cleaning arc is performed. Next, the cleave angle and end-face quality are checked. If the measured cleave angle greater than its set threshold or fiber chipping is detected, the buzzer will sound and an error message warns the operator. The splicing

procedure pauses. If no error message is displayed, the below stated end-face conditions are used for visual inspection. If observed, remove the fiber from the splicer and repeat fiber preparation. These visual defects may cause a faulty splice.

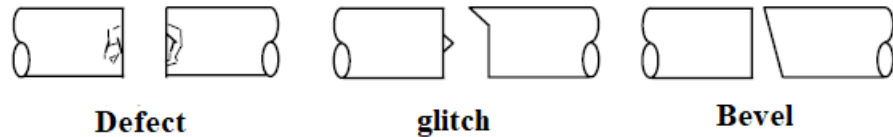

- b) After fiber inspection, the fibers are aligned core-to-core or cladding-to-cladding. Cladding axis offset and core axis offset measurements can be displayed.
- c) After completion of fiber alignment, arc discharge is performed to splice the fibers.
- d) Estimated splice loss is displayed upon completion of splicing. Splice loss is affected by certain factors stated in Page 27. These factors are taken into account to calculate, or estimate, splice loss. The calculation is based on certain dimensional parameters, such as MFD. If either the cleave angle measured or the estimated splice loss exceeds its set threshold, an error message is displayed. If the spliced fiber is detected as abnormal, such as "Fat", "Thin" or "Bubble", an error message is displayed. If no error message is displayed but the splice looks poor by visual inspection through the monitor, it is strongly recommended to repeat the splice from the beginning.

NOTE

- ◆ Splice point sometimes looks a bit fatter than other parts. This is considered a normal splice, and does not affect splice loss.
- ◆ To change threshold for estimated splice loss or cleave angle, see [Splice Mode] for details.
- ◆ Splice loss may be improved in some cases by additional arc discharges.

Press  button for an additional arc discharge (re-arc). Splice loss estimate and splice check are performed again. Splice loss may be worsened in some cases by additional arc discharges (re-arcs). Additional arc discharge can be set to "disabled", or limited to the number of additional arcs.

- ◆ Splicing result is automatically saved in splicer memory

5. Heating protection sleeve

- a) Transfer fiber with protection sleeve to tube heater. Protection sleeve is placed in the center of the tube heater.
- b) Place fiber with protection sleeve in the middle of tube heater. While placing it in the tube heater, apply some tension on the fiber so the tube heater lids automatically close. Then press  button starting heating process.

NOTE

- ◆ Make sure the splice point is located at the center of the protection sleeve.
- ◆ Make sure the strength member in the protection sleeve is placed downwards.
- ◆ Make sure no fiber twist.
- ◆ Press  button to turn on. The buzzer beeps and the HEAT LED turn off when tube heating is completed.
- ◆ Open tube heater lids and remove protected fiber from the tube heater. Apply some tension to the fiber while removing it from the tube heater.
- ◆ Visually inspect the finished sleeve to verify no bubbles or debris/dust is present in the sleeve.

Menu Operation

Press  button to enter splicer menu, there are six main menus: “Splice Mode Menu”, “Heat Mode Menu”, “ Calibration and Maintenance Menu”, “Data”, “Splice Setting Menu”, and “Setting Menu” as shown below:

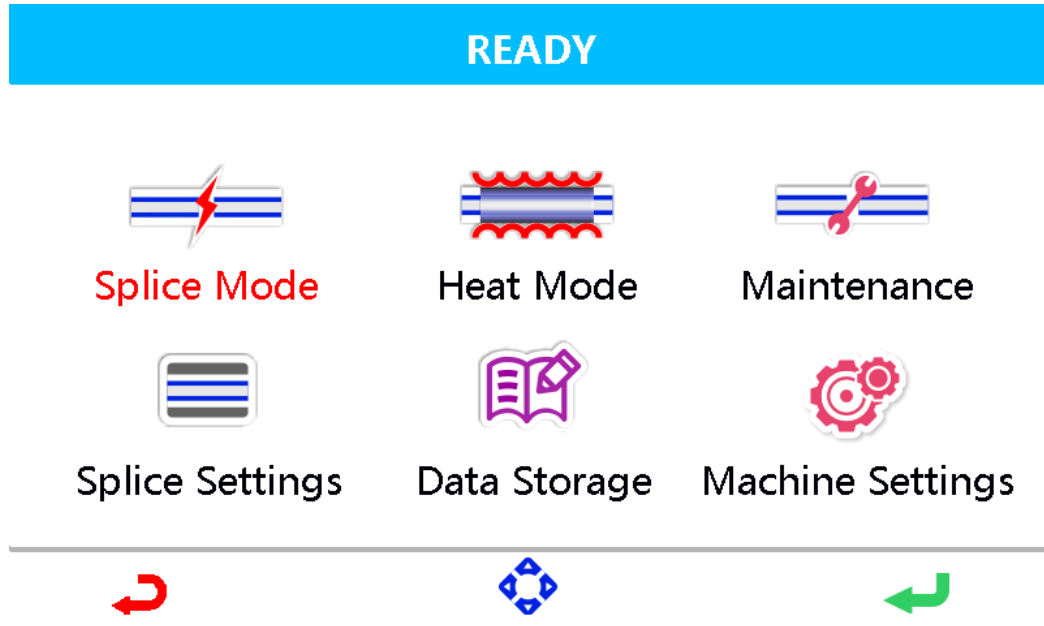



1. Splice Mode Menu

A. Splice Mode

In the main menu item in the figure above, select the fusion mode option and click  to enter, as shown in the figure below:



Select a suitable splicing mode according to the type of fiber to be spliced. Select

the splicing mode by   and click  to confirm the selection.

It is recommended to select “1 AUTO SM / NZ / DS / MM” mode for normal operation. In this mode, the splicer automatically adjusts the splicing parameters according to the condition of the spliced fiber, which is easy to operate.

➤ **Database**



Mode No.	Splice Mode	Description
1	AUTO	For splicing in most cases, in which the splicer will automatically adjust splice parameters according to fiber type. Automatic arc calibration works in this splice mode.
2	2~240	Multiple splicing modes can be edited by the user.

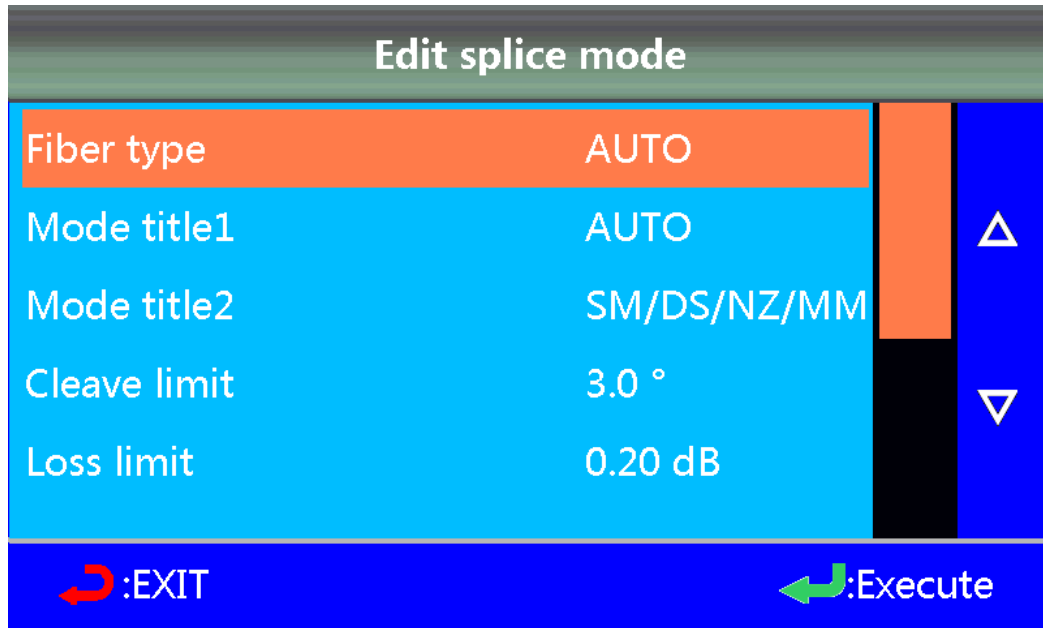

B. Edit Splice Mode

Splicing parameters in each splice mode can be modified.

In [Select Splice Mode] menu, press  button to enter “Edit Splice Mode” and modify splice mode as shown above:



Press  or  button to select the parameter to be modified, press  button to enter parameter setting.

Press  or  button to modify parameter, press  button to confirm.

NOTE

In AUTO mode, certain parameters cannot be changed.

Parameter	Description
Fiber Type	List of splice modes stored in database is displayed. A selected splice mode stored in the database area is copied to a selected splice mode in the user-programmable area.
Mode Title1	Title for a splice mode expressed in up to 10 characters.
Mode Title2	Detail explanation for a splice mode expressed in up to 10 characters. Title2 is displayed at the [Splice Mode Select] menu.
Cleave Limit	Set cleave limit. An error message is displayed if the cleave angle of either the left or right fiber ends exceeds the selected threshold.

Loss Limit	An error message is displayed if the estimated splice loss exceeds selected threshold (loss limit).
Arc Power	In SM/DS/MM/NZ/AUTO modes, the Arc Power is fixed at 40 bits.
Arc Time	Arc Time is fixed at 1500 ms for SM and DS modes, 2000 ms for NZ mode, and 3000 ms for MM mode. This is automatically set depending on the fiber type when AUTO mode is selected.
Cleaning Arc	A cleaning arc burns out micro dust on the surface of the fiber with an arc discharge for a short period of time. The duration of the cleaning arc can be changed by this parameter.
Rearc Time	Splice loss may be improved by an additional “rearc” discharge in some cases. The duration of this additional arc can be changed by this parameter.

2. Heater Mode

There are 30 user-programmable heating modes. Select one best suitable for the protection sleeve used.



Each tube-heating mode is optimized for a type of protection sleeve. These modes can be found in database area for reference. Copy the appropriate one and paste it to the user-programmable area. The operator can edit the user-programmable modes.

A. Select Heater Mode

In “Splice Mode Menu”, press  button to select “Heater Mode”, as shown below:

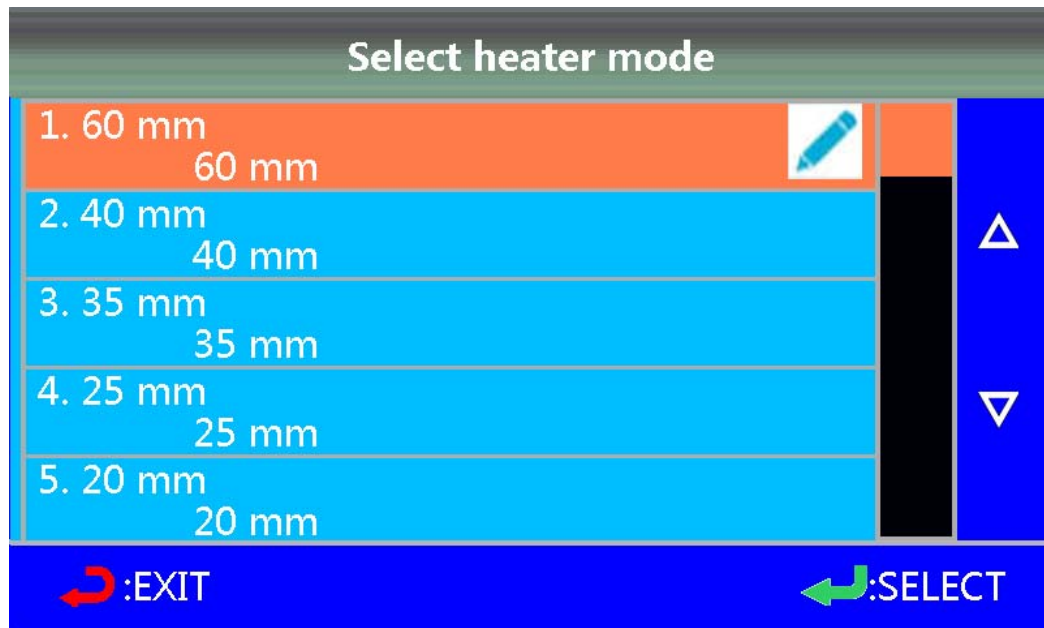
Select the heater mode most suitable for the protection sleeve to be used.



Press   button to select a heater mode, press  button to confirm.

B. Edit Heater Mode

Tube-heating conditions stored in heater mode can be edited or changed.



Editable parameters include: Heat Time, Heat Temp (heating temperature) and etc. Heat Time will automatically adjust according to atmospheric conditions e.g: ambient temperature. The real Heat Time may vary from set Heat Time.

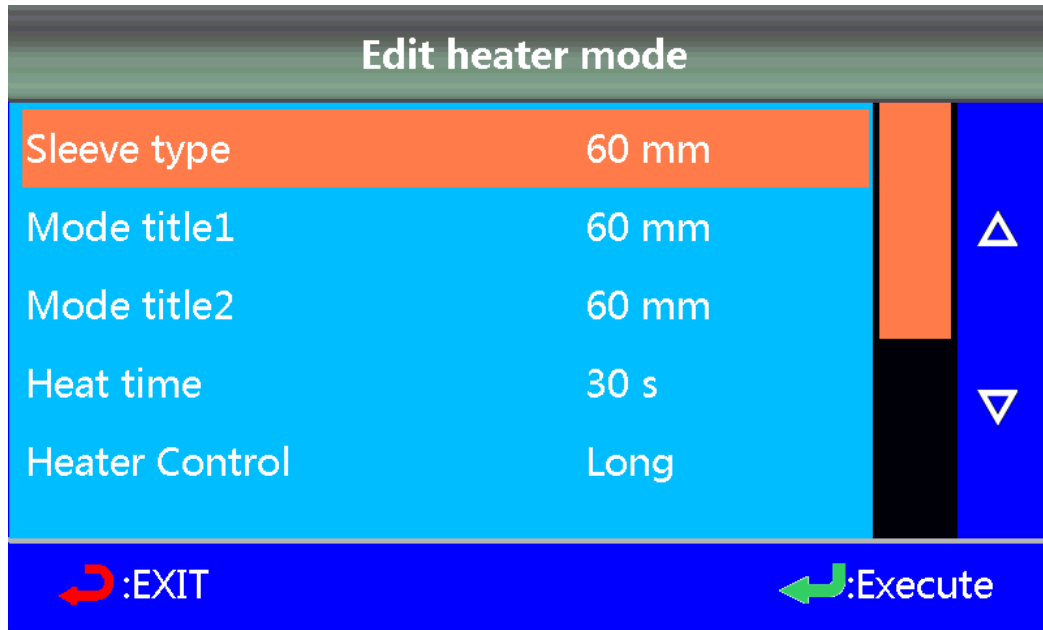

Sets heating temperature. Fiber coating may melt if Heat Temp is over 190°C

Sets Finish Temp (Finish Temperature). When heater approaches this temperature the buzzer beeps announcing the sleeve is cooled down and is ready to be taken out of the heater.

In “Select Heater Menu”, press  button to enter “Heater Mode Edit” menu as shown below:



Press  or  button to select the parameter to be modified, press  button to enter parameter setting.

Press  or  button to modify parameter, press  button to confirm.

Editing heating mode parameters and meaning

Parameter	Description
Sleeve Type	20mm, 25mm, 35mm,40mm, 60mm
Mode Title 1	Editable display information for heating mode page
Mode Title 2	Editable display information for heating mode page
Heating Time	0-240s adjustable
Heating Control	Long tube, medium tube, micro tube
Center Heating Temperature	100-255° adjustable
Both sides	100-255° adjustable



Heating Temperature	
Cooling Time	0-100s adjustable
Heating Mode	Center edge, Center

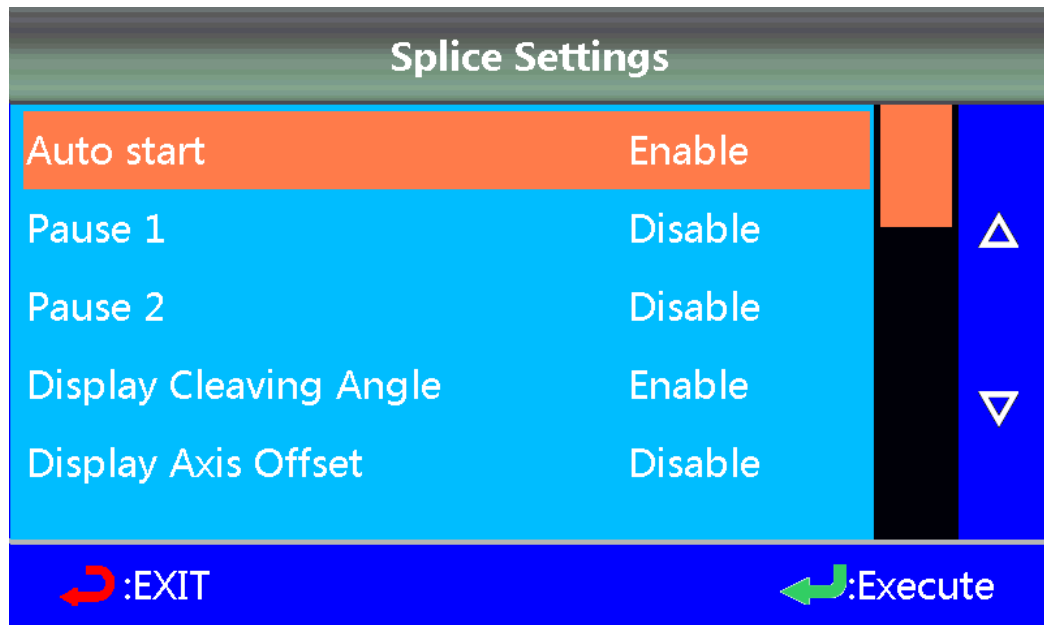

3. Splice Set

Splice Set include: Auto Start, Pause, Cleave Angle Display and etc.

In “Splice Mode Menu”, press  button to select “Splice Option”, as shown above:



Press   button to select the parameter to be modified, press  button to enter parameter setting.

Press   button to modify the parameter and press  button to confirm.

4. Data Save

LP-FS-PRO-X6 stores up to 20480 splicing results. In “Splice Memory” menu,

operator can review saved results or delete saved results.

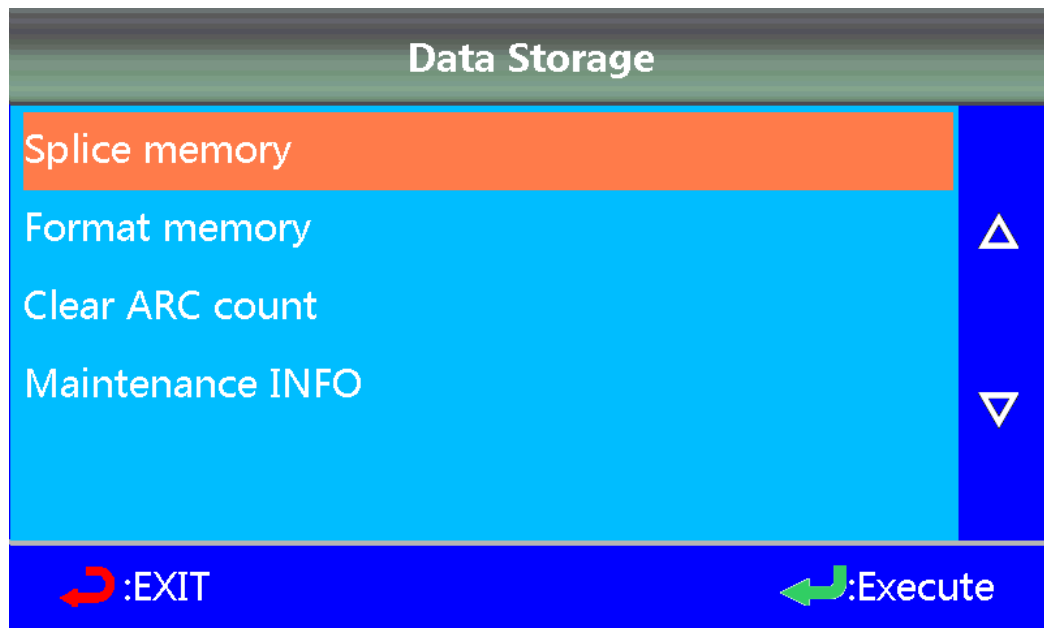

5. Set Menu



This menu is used to change language and power save settings. etc.



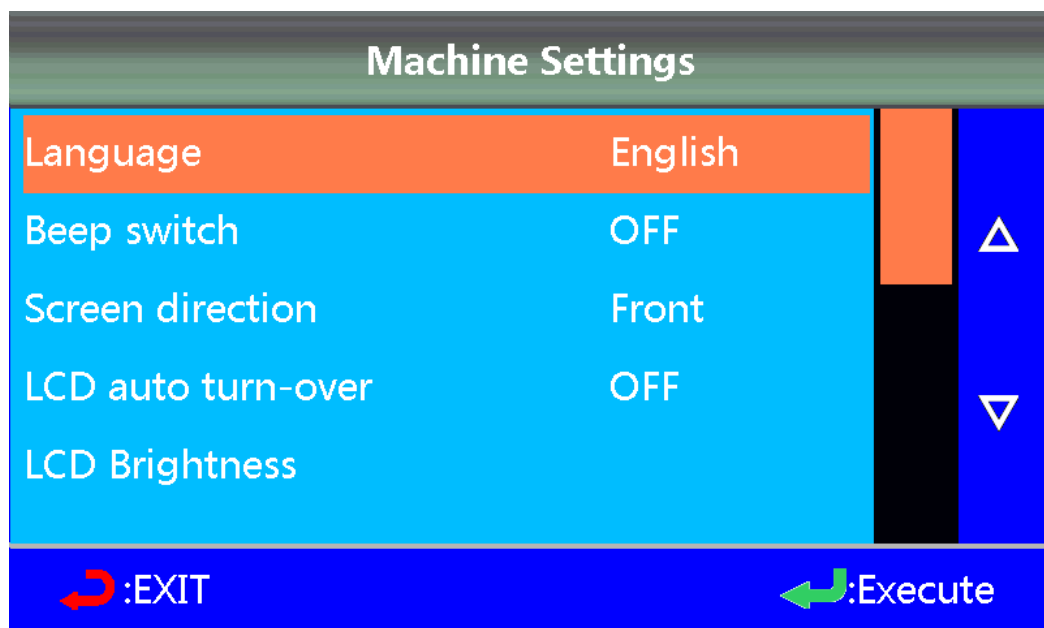

Press button to select “Management Menu”, as shown below:



A. Language

In “Set”, press   button to select “Lang/语言/”, press  button to enter as shown below:



Press   button to select the target language and press  button to confirm.

B. Beep switch

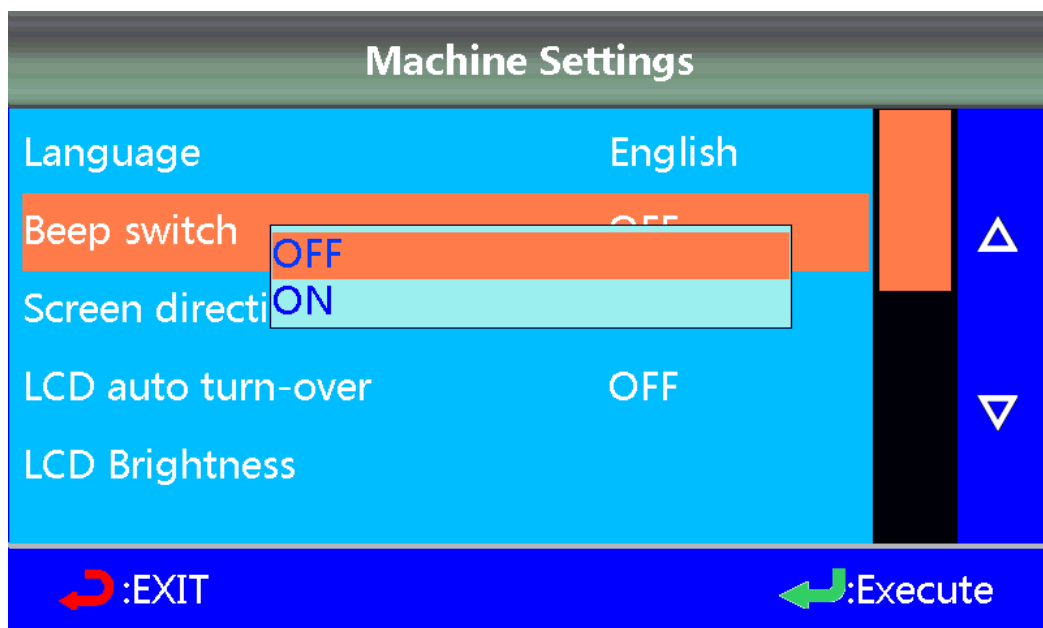

C. Screen direction

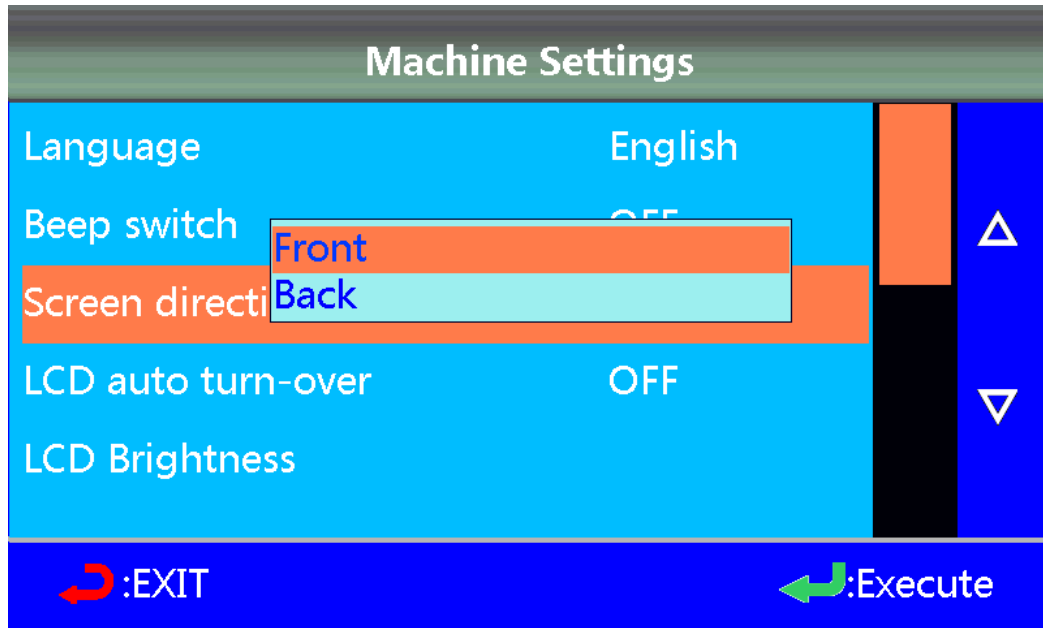

D. Lcd switch

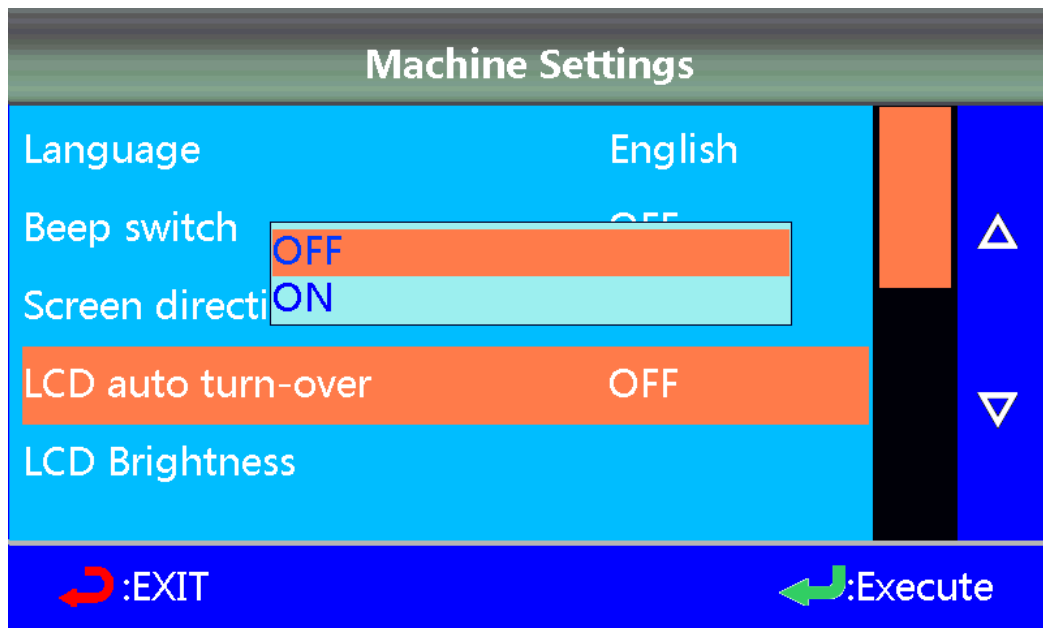

E. Auto heat switch

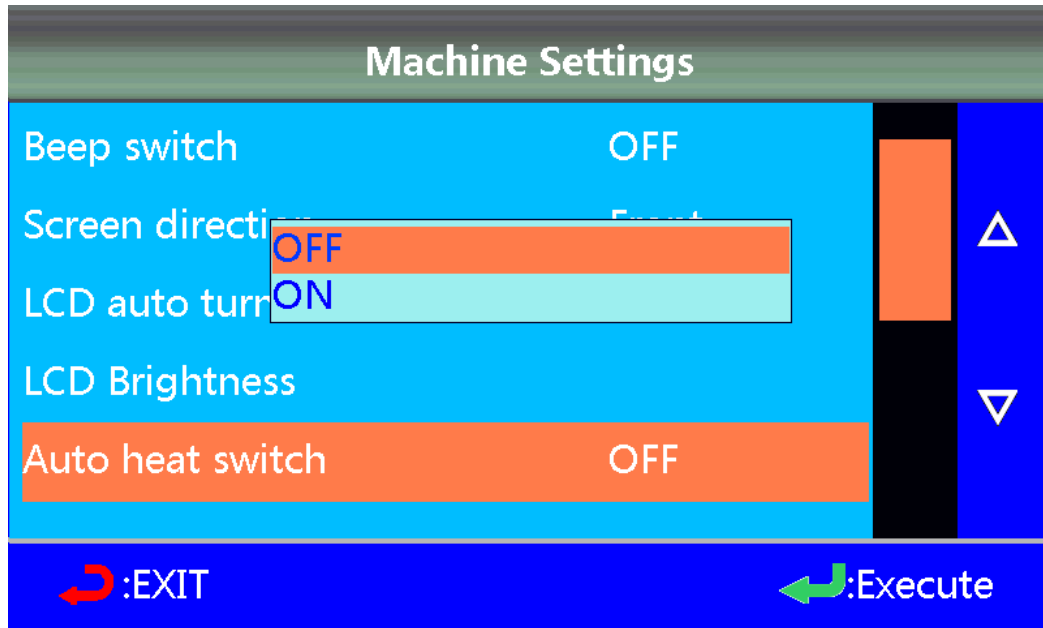

F. Power Save

Power Save function is important for energy conservation which turns off the power supply to the LCD monitor if the splicer performs no operation after a certain period of time (0 – 20 minutes adjustable). LED indicator turns on after Power Save is enabled, pressing any key to turn back on the LCD monitor. Splicer can also automatically turn off after certain period of time without operation (0 – 20 minutes adjustable)

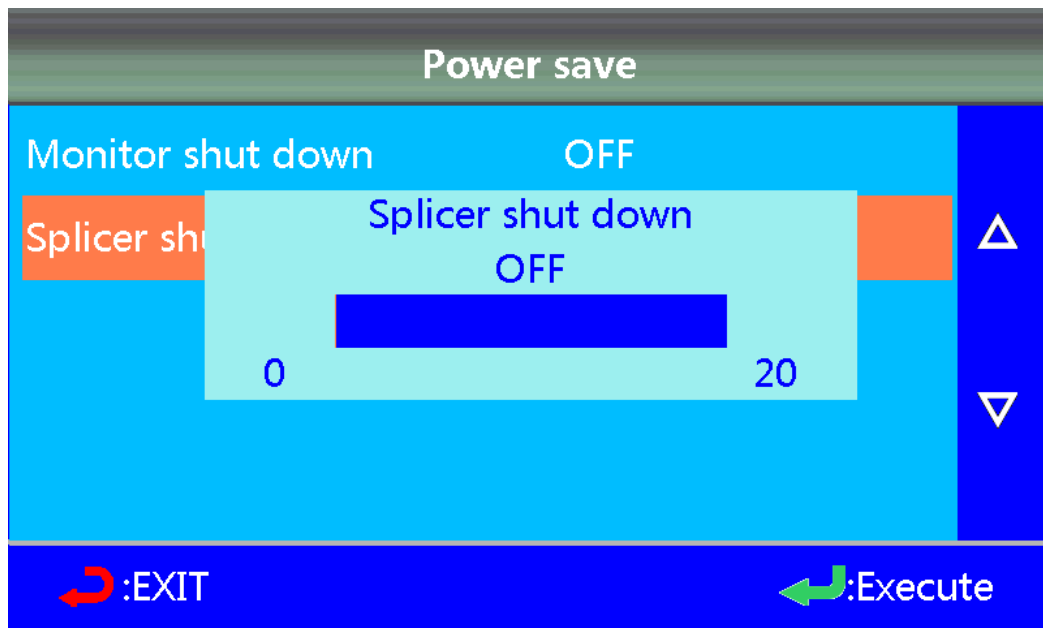
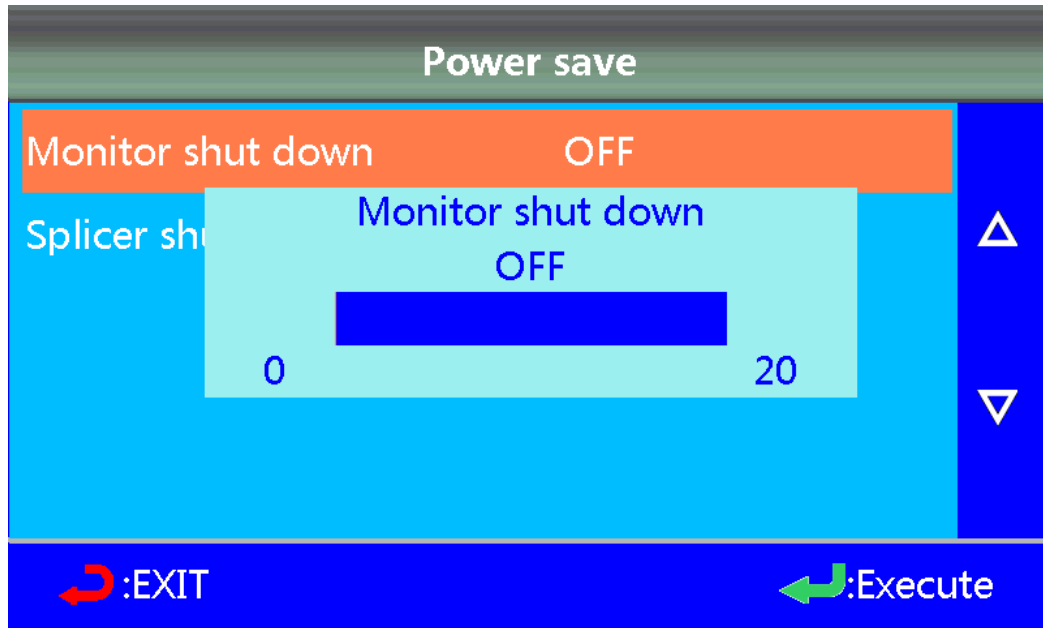

G. LCD brightness

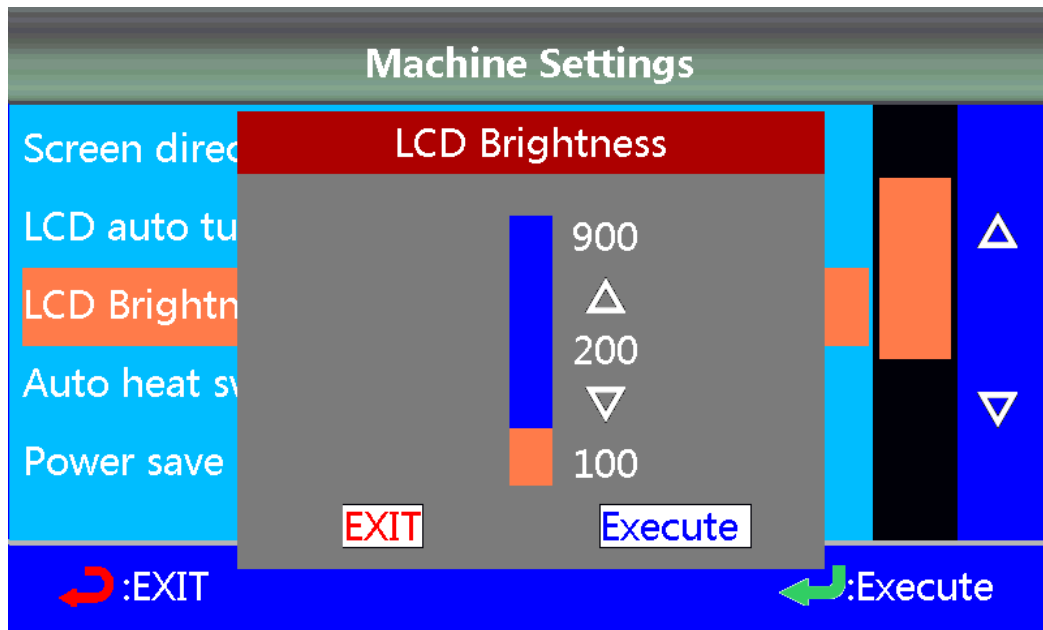

H. Set calendar

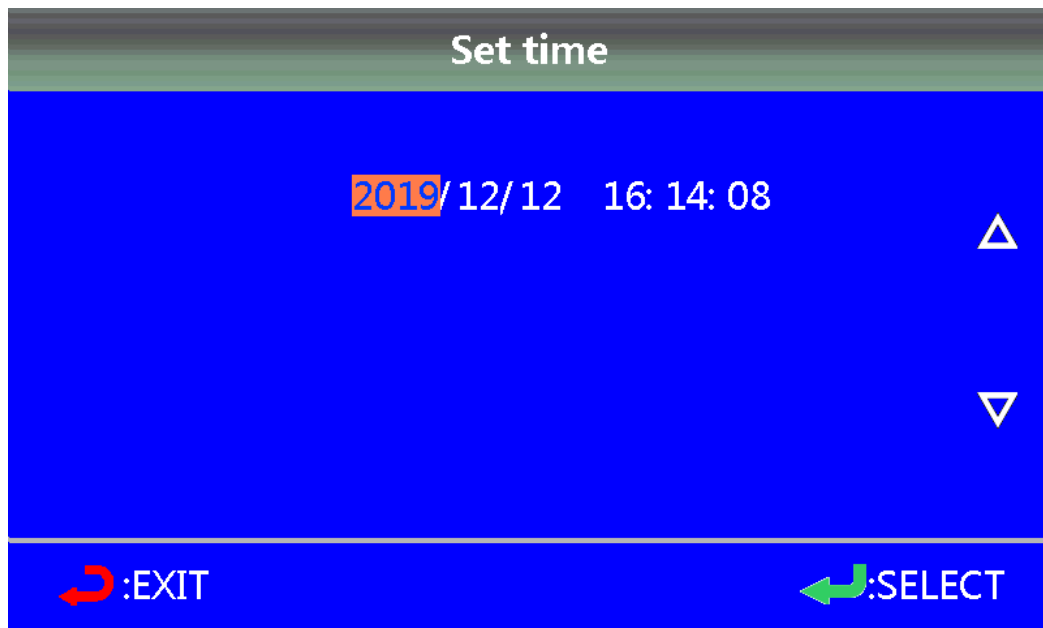

I. Sensor value

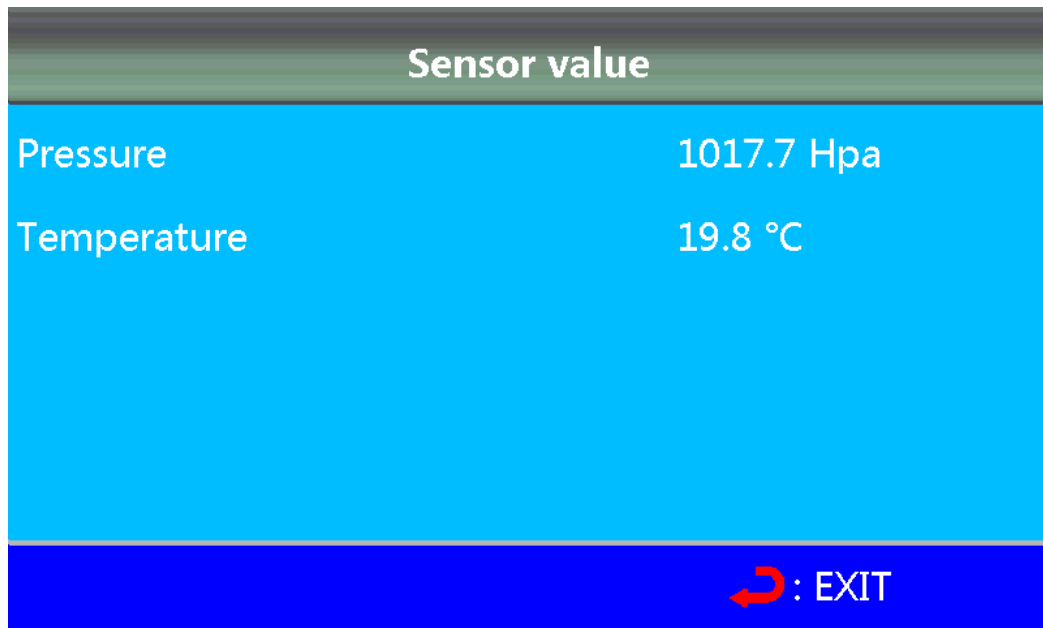

J. Load Default

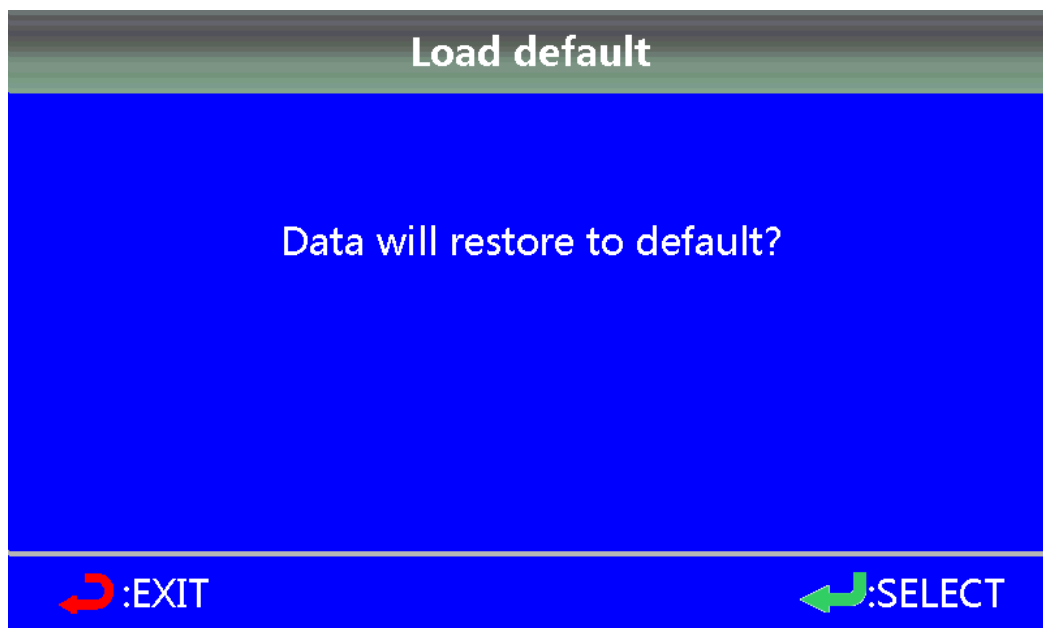

K. Software Version Upgrade

This function is for users to upgrade the software by downloading the latest software version released by Linkedpro.



Upgrade steps:

- Connect the computer in the standby interface of the splicer. The screen of the splicer displays the USB connection, and the computer displays the new removable disk.



- Copy the upgrade package bin format file to the folder update under the new removable disk, and then unplug the USB.



- In the splicer setting menu, open the update option through , select the firmware, select the firmware file to be upgraded through , and start the upgrade through . After the upgrade is completed, it will automatically shut down and restart to use normally.

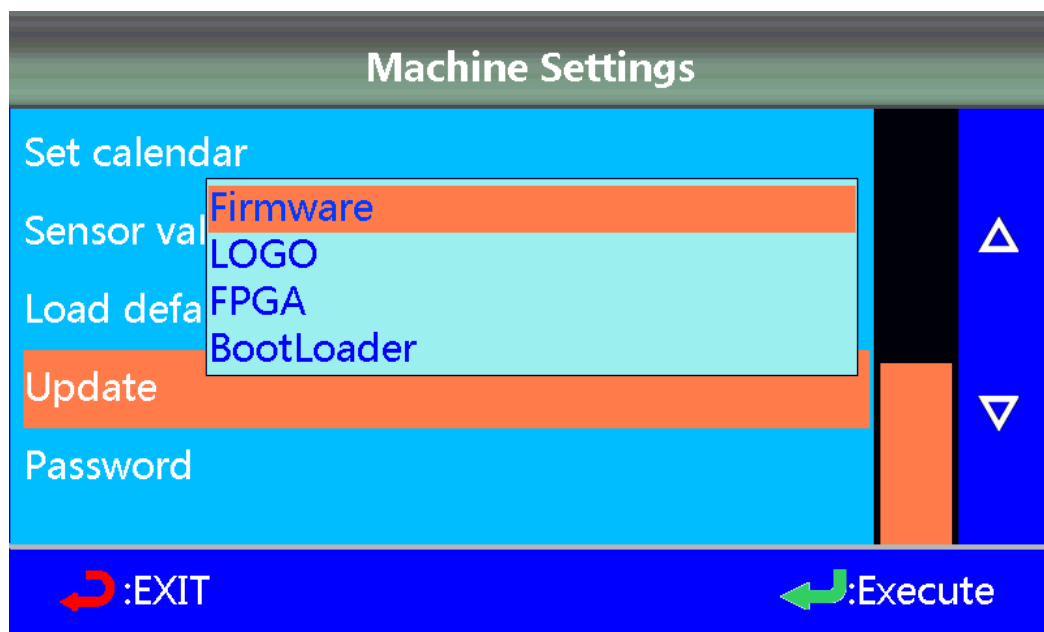

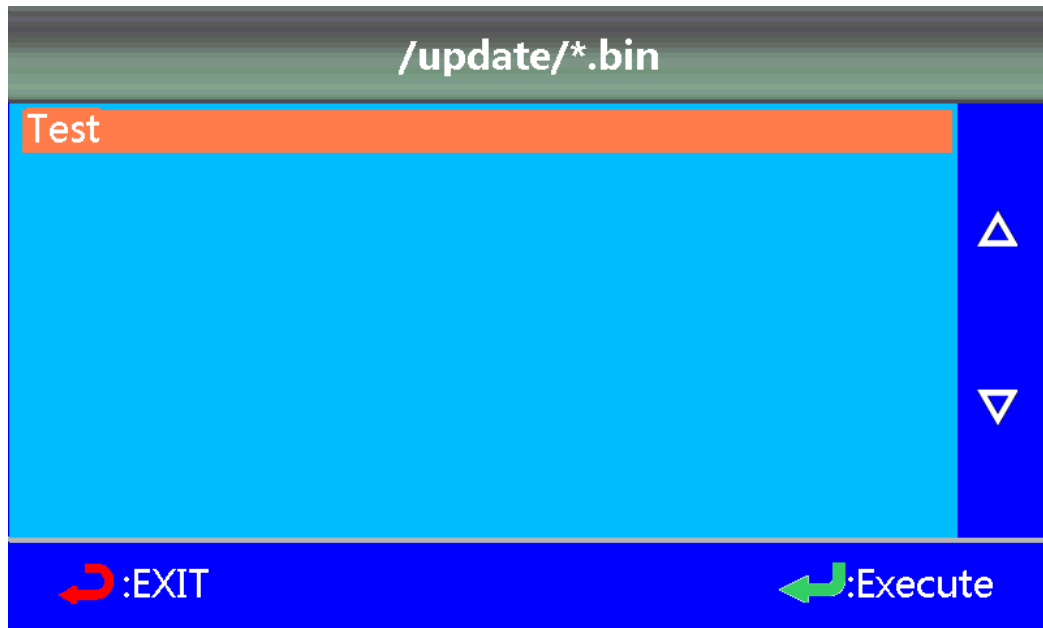

L. Password

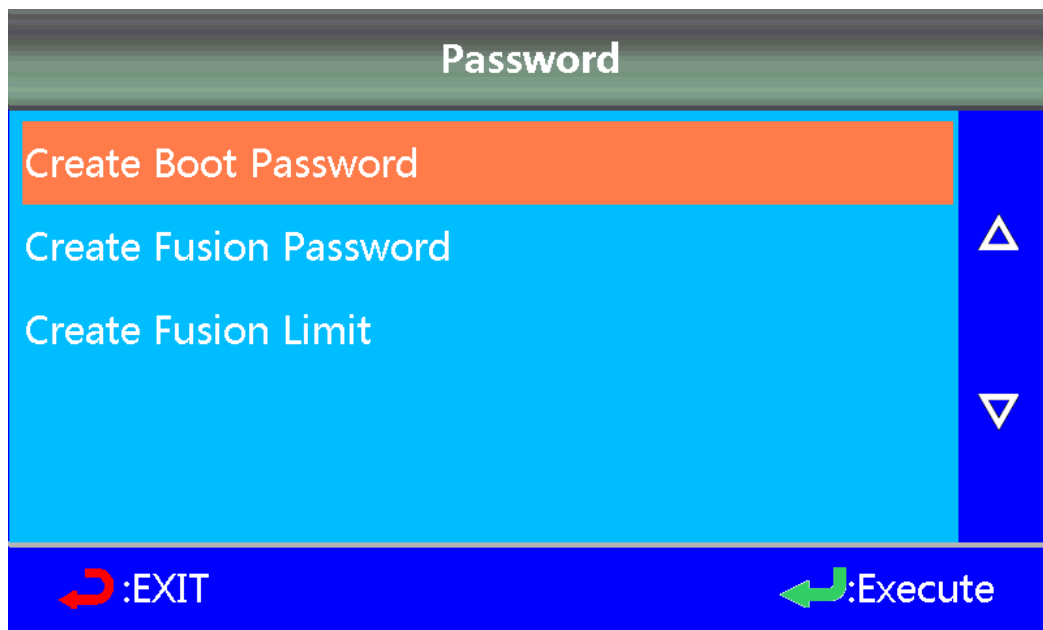

6. Maintenance Menu

LP-FS-PRO-X6 has the ability to perform routine maintenance, in “Maintenance” Menu, operator can Arc Calibration, Motor Drive, Screen Adjust, replace electrodes and stabilize electrodes.

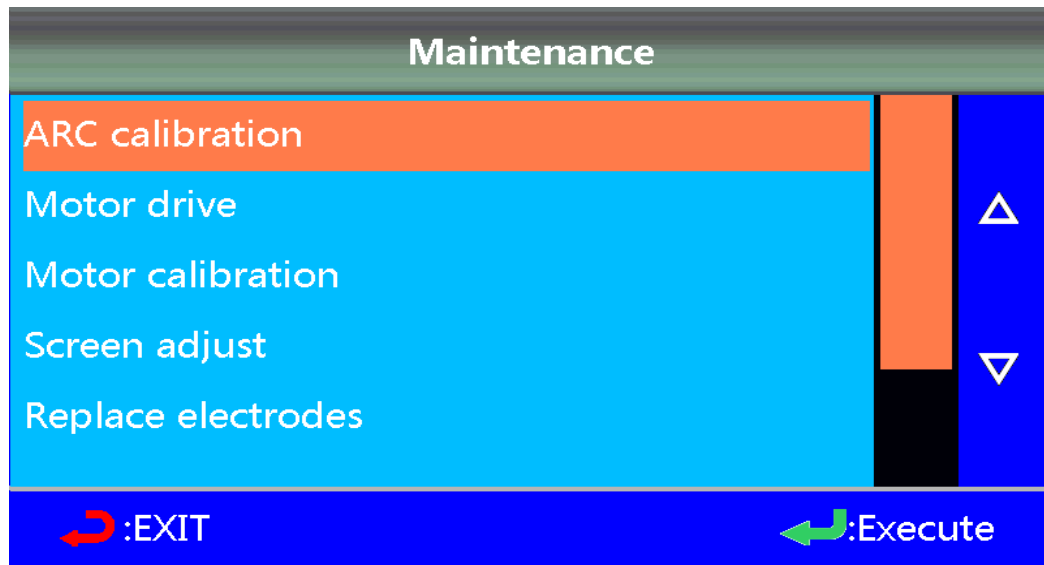

A. Discharge correction

This function is mainly to automatically adjust the discharge coefficient according to the user's current area.

In the menu interface, use the "Maintenance" option, select "Discharge Calibration" to perform this operation.

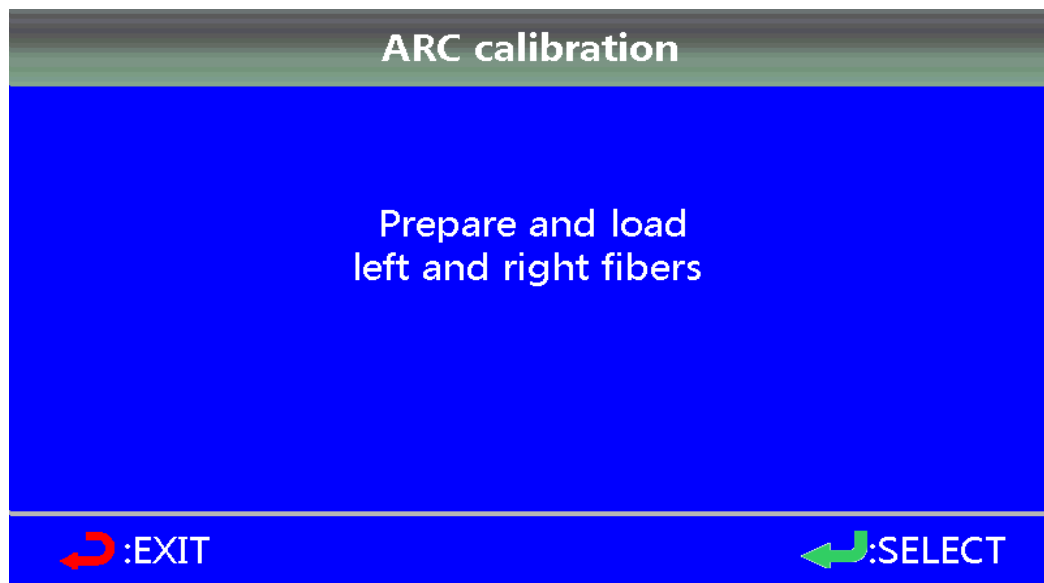



Through "discharge correction", the discharge parameters are adjusted on the spot in real time to optimize the welding result.

B. Motor driven

This function is mainly to manually drive the motor and check whether the motor is abnormal.

In the menu interface, select the "Maintenance" option, select "Motor Drive" to perform this operation.

Select the motor to be driven by  : left advance, right advance, X axis, Y axis, upper lens and lower lens. Change the motor driving speed by , where the value shown in [xx] represents the number of driving steps.

Implement the drive motor through   : verify the normality of the motor.

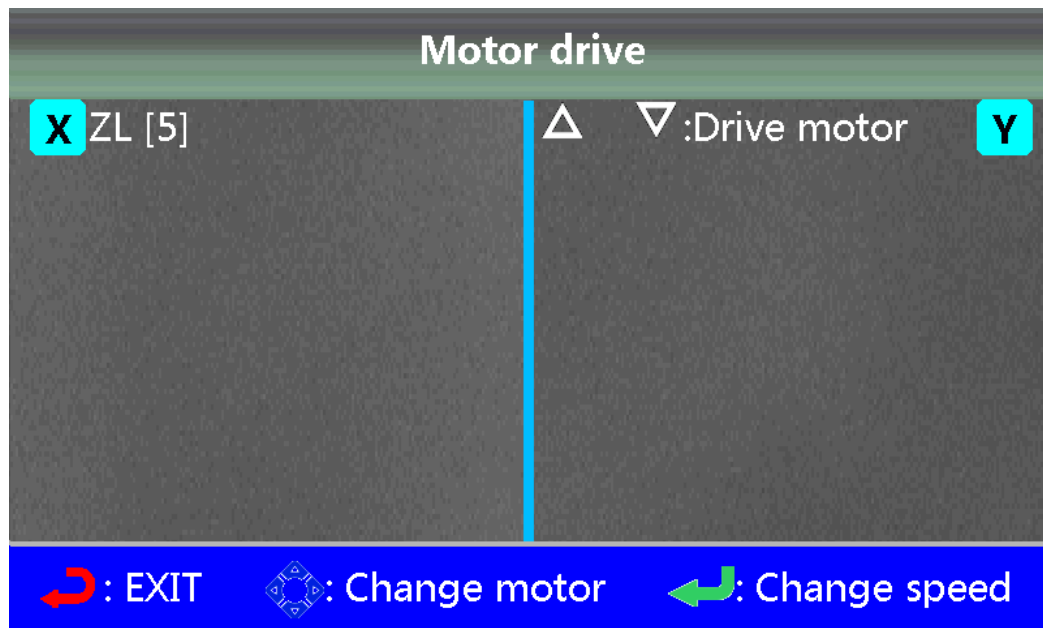

C. Motor Calibration

This function is mainly to automatically adjust the motor to achieve the best working position.

In the menu interface, select the "Maintenance" option, select "Motor calibration" to perform this operation.

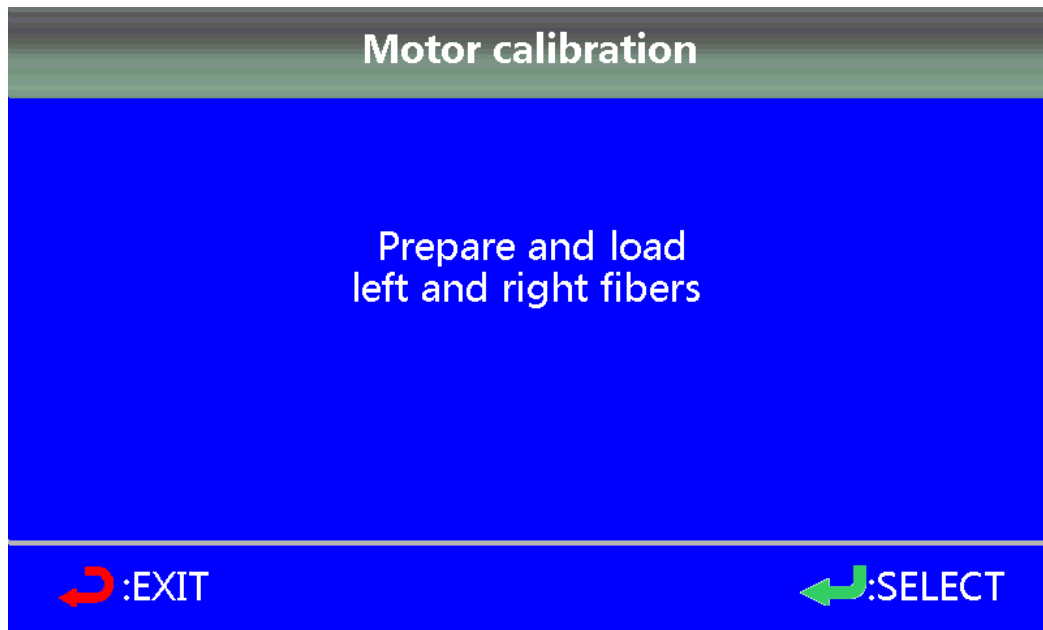

After “Motor Calibration” , the motor position will be adjusted automatically, and some “Motor Failure” errors will be resolved to resume normal work.

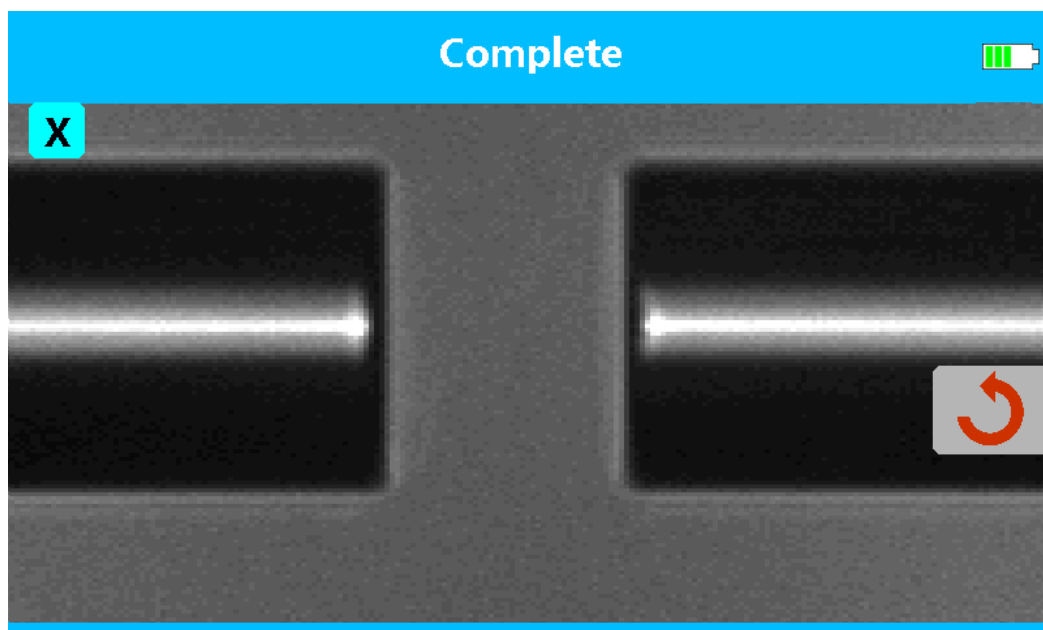

D. Display adjustment

Change the image display position with display adjustment.

In the menu interface, select the "Maintenance" option, select "Display adjustment calibration" to perform this operation.

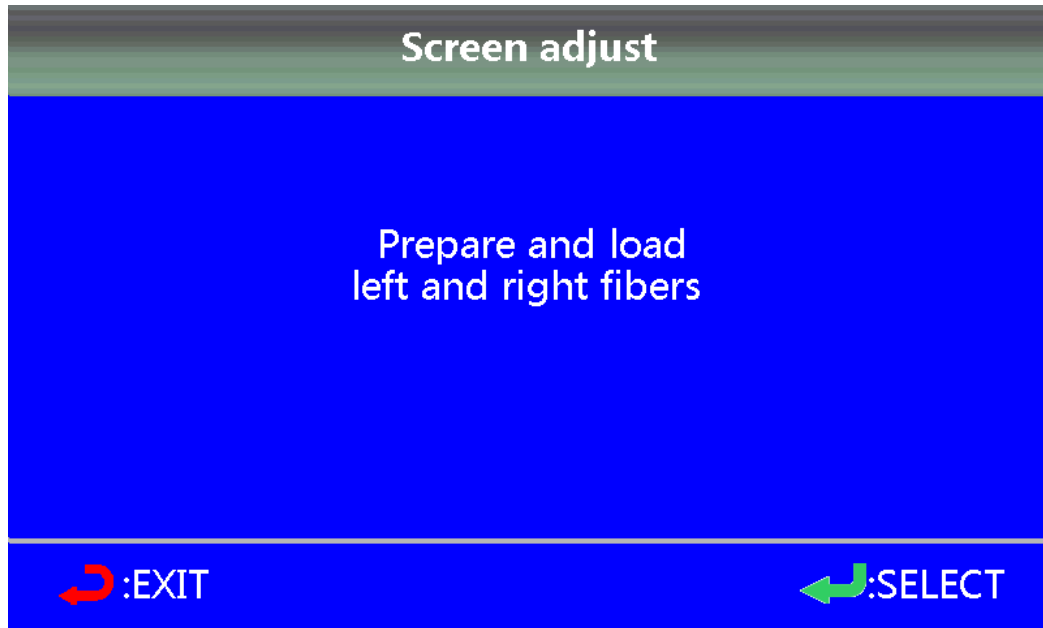

You need to place the cut fiber properly.

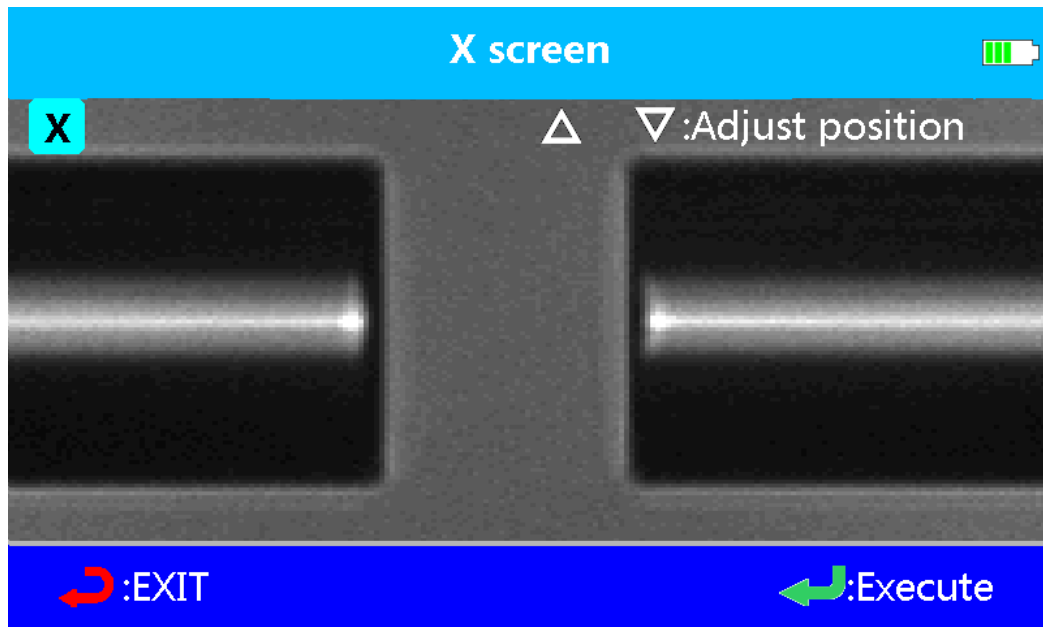

E. Replace the electrode

In the menu interface, select the "Maintenance" option, click  button to confirm the entry, and select "Replace the electrode" to perform this operation. As shown below:

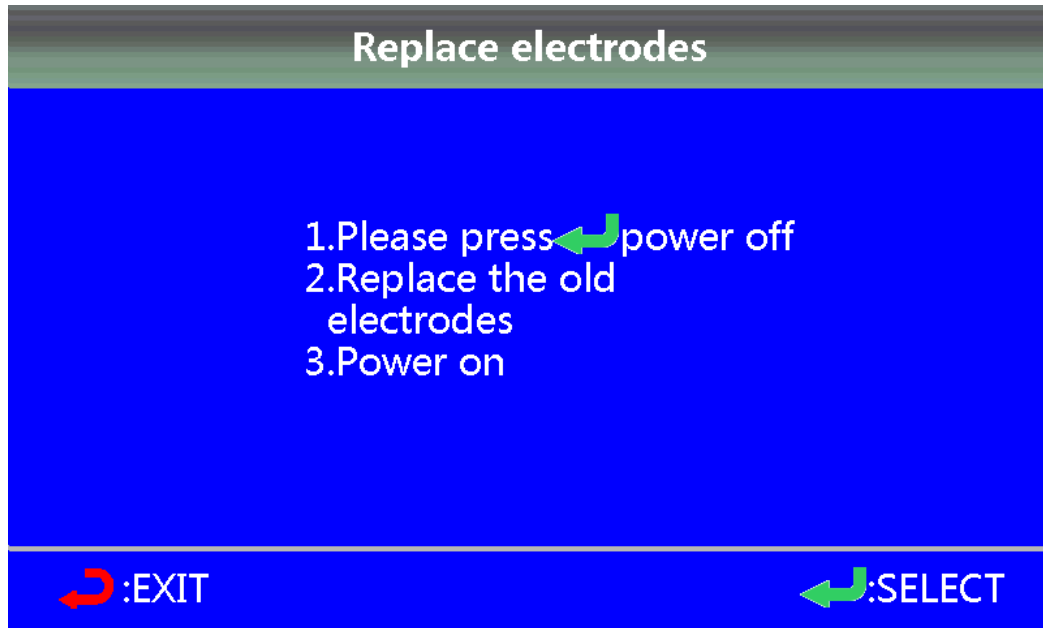

Follow the instructions of this machine and follow the steps to replace the electrodes.



F. Stabilizing electrode

According to the working performance curve of the electrode needle, the discharge phenomenon of the first few times is unstable, and the "stabilizing electrode" operation can be performed to make the electrode needle in a stable working state. During the stabilization of the electrode, discharge correction is performed continuously until the stabilization of the electrode is completed.

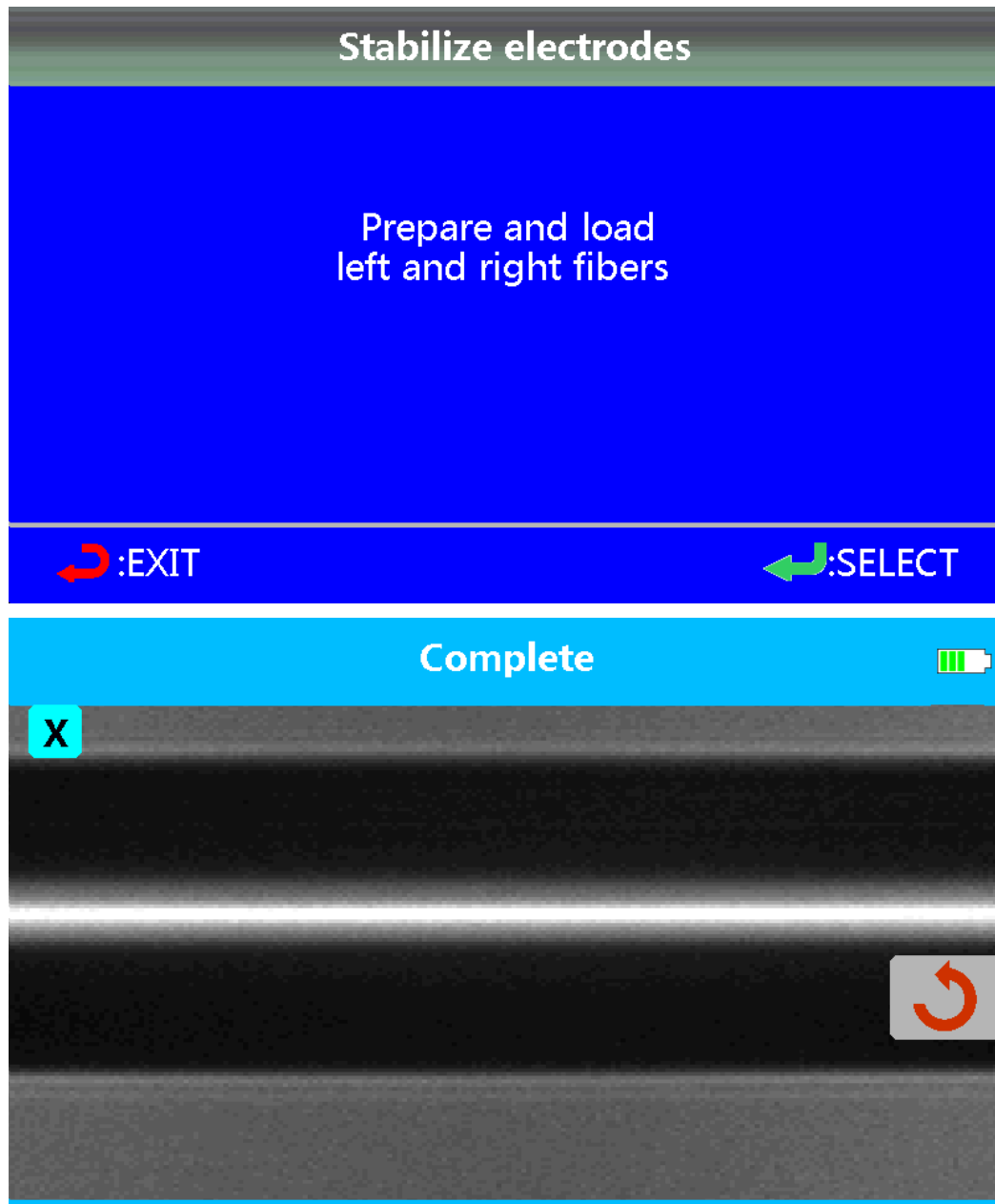







G. Hardware

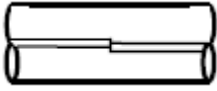

Select debug mode and user mode. If you need to use it, please use it under the guidance of the factory technicians.

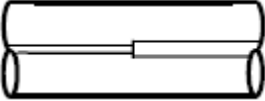

Common Problems and Troubleshooting

Phenomenon	Reason	Solution
Core axial misalignment 	Dust or dirt is on the V-groove or the clamp chip.	Cleaning V-groove and the clamp chip.
Wrong core angle 	Dust or dirt is on the V-groove or the clamp chip.	Cleaning V-groove and the clamp chip.
	Bad fiber end-face.	Check if the fiber cutter is working well.
Core steps 	Dust or dirt is on the V-groove or the clamp chip.	Cleaning V-groove and the clamp chip.
Core bending 	Bad fiber end-face.	Check if the fiber cutter is working well.
	Low pre-discharge intensity or short pre-discharge time.	Increase [Pre-discharge intensity] and / or increase [Pre-discharge time].
Mode field diameter mismatch 	The discharge intensity is too low.	Increase [discharge intensity] and / or increase [discharge time].
Dust burning 	Bad fiber end-face.	Check the working condition of the fiber cleaver
	Insufficient fiber cleaning.	Clean the fiber thoroughly or increase the [clean discharge time]

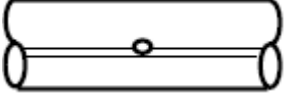
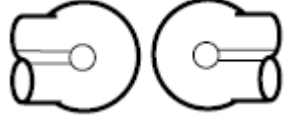
Common Problems and Troubleshooting

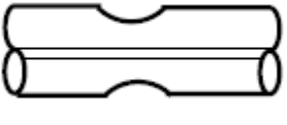
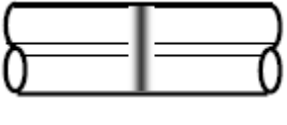
Bubble 	Bad fiber end-face.	Check the working condition of the fiber cleaver
	Inadequate arc power or time.	Increase [Pre-discharge intensity] and / or increase [Pre-discharge time].
Fiber separation 	Fiber advance is too small.	Do [motor calibration] experiment
	Excessive arc power or time.	Reduce [pre-discharge intensity] and / or reduce [pre-discharge time]
Too thick 	Fiber advance is too big.	Reduce [overlap amount] and do [motor calibration] experiment.
Too fine 	Discharge intensity is inappropriate.	Do [discharge correction]
	Inadequate arc parameters in other splice modes.	Adjust [pre-discharge intensity], [pre-discharge time] or [fiber advance amount]
line 	Inadequate arc parameters in other splice modes.	Adjust [pre-discharge intensity], [pre-discharge time] or [fiber advance amount]

NOTE

When different fibers (different diameters) or multimode fibers are spliced, sometimes a vertical line is generated at the splicing point, which does not affect the splicing results, such as splice loss and joint strength.

Warranty Information

1. Terms of Warranty

All Linkedpro products are warranted against defective material and workmanship for a period of one (1) year from the date of shipment to the original customer. Any product found to be defective within the warranty period would be repaired or replaced by Linkedpro free of charge.

In no case will Linkedpro liabilities exceed the original purchase price of the product.

2. Exclusions

The warranty on your equipment shall not apply to defects resulting from the following:

- *Unauthorized repair or modification*
- *Misuse, negligence, or accident*
- *Consumptive parts (e.g electrodes)*

Linkedpro reserves the right to make changes to any of its products at any time without having to replace or change previously purchased units.

3. Warranty Registration

A warranty registration card is included with the original shipment of equipment. Please take a few moments to fill out the card and mail or fax it to the local Customer Service Center of Linkedpro to ensure proper initiation of your warranty term and scope of your warranty.

4. Returning Instruments

To return instrument for reasons of yearly calibration or other, please contact the local Customer Service Center of Linkedpro to obtain additional information and a RMA# (Return Materials Authorization number). And describe briefly reasons for the return of the equipment, to allow us offer you more efficient service.

NOTE

To return the instrument in the case of repair, calibration or other maintenance, please note the following:

- Be sure to pack the instrument with soft cushion like Polyethylene, so as to protect the shell of the instrument.
- Please use the original hard packing box. If use other packing material, please ensure at least 3 cm soft material around the instrument.
- Be sure to correctly fill out and return the warranty registration card, which should include the following information: company name, postal address, contact, phone number, email address and problem description.
- Be sure to seal the packing box with exclusive tape.
- Be sure to ship to your representative or the agent of the Company in a reliable way.