



.....R@6%\$\$ (, A5L RESS Li-ion Battery User's Guide

End User Documentation

Rev 1.1

March-14-2023

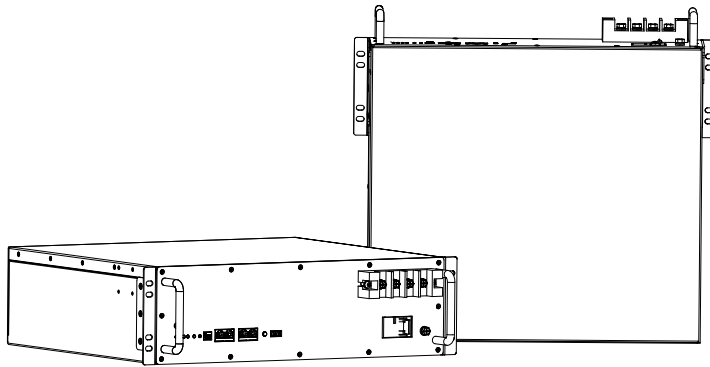

DOCUMENT NOTICE: The information contained in this manual is the property of SYSCOM ("SYSCOM") and is subject to change without notice. SYSCOM reserves the right to make changes in the design of its products

or components as progress in engineering and manufacturing may warrant. It is the customer's responsibility to satisfy itself as to whether the information contained herein is adequate and sufficient for a user's particular use. It is the further responsibility of each user to ensure that all applications of SYSCOM's products are appropriate and safe based on conditions anticipated or encountered during use. This document does not create any additional obligation for SYSCOM and does not constitute additional warranties and representations.



WARNING: Explosion, Electrocution, Or Fire Hazard

- ☑ A battery can present a risk of electric shock, burns from high short circuit current, fire, or explosion.
- ☑ Observe proper precautions.
- ☑ Ensure the cables are properly sized.
- ☑ Ensure clearance requirements are strictly enforced around the batteries.
- ☑ Ensure the area around the batteries is well ventilated and clean of debris.
- ☑ Always use insulated tools. Avoid dropping tools onto batteries or other electrical parts.
- ☑ If a battery must be removed, always remove the grounded terminal from the battery first. Make sure all devices are disconnected.
- ☑ All devices must be disconnected when update the BMS software.
- ☑ DO NOT short the battery terminals.
- ☑ DO NOT incinerate, crush, or disassemble.
- ☑ DO NOT reverse connections (polarity) from charger to battery.
- ☑ DO NOT operate battery beyond published voltage and current limits.



IMPORTANT

- ☑ When installing batteries, leave adequate clearance between batteries.
- ☑ When replacing batteries, use the same part number of batteries.
- ☑ Avoid any fall or collision during the installation process.
- ☑ Do not remove the battery components. The maintenance of the battery should be carried out by a professional engineer.
- ☑ Do not expose the Li-ion battery to heat in excess of 55°C during operation, 60 °C in storage; Do not incinerate or expose to open flames.
- ☑ The SOC is 50% when shipped from factory, it needs to be recharged in time for long time storage.

Rack Type Li-ion Battery

This series rack type li-ion batteries are designed for the residential energy storage market (RESS) which combines safe and reliable LiFePO4 prismatic cells with RESS dedicated BMS to guarantee high reliability, safety, and scalability when used with different inverter. The product can be installed in a 19" or 21" standard cabinet/rack or wall mounted.

It provides 48V and 51.2V configuration to adapt to the different requirement.

This document is intended for use by anyone required to install and operate Syscom rack type Li-ion batteries. Be sure to review this manual carefully to identify any potential safety risks before proceeding.

The owner must be familiar with all the features of this product before proceeding.

Failure to install or use this product as instructed can result in damage to the product that may not be covered under the limited warranty.

Product Introduction

The rack type Li-ion batteries are shown in Figure 1.



Figure 1. Rack type Li-ion batteries appearance

The front panel of the battery is shown in Figure 2.

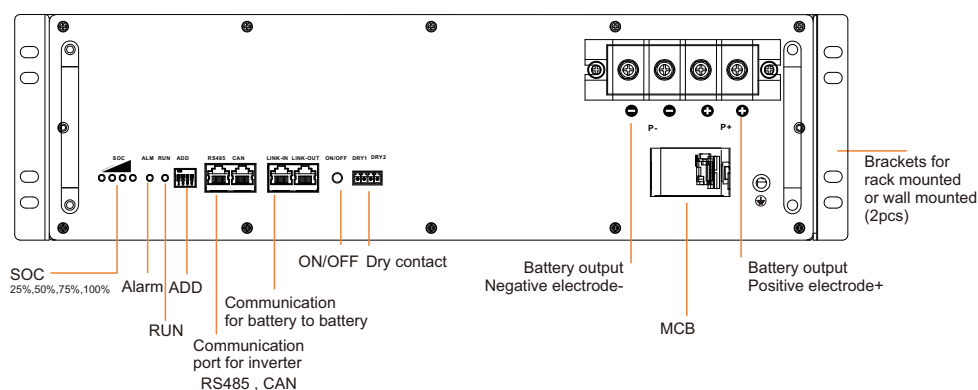
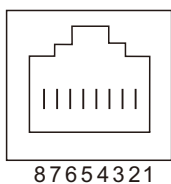

Figure 2. Front panel of rack mounted Li-ion batteries

Communication port with inverter



RS485 PIN MAP

RJ45 PIN	Description
1	RS485_B
2	RS485_A
3,4,5,6,7,8	NC

CAN PIN MAP

RJ45 PIN	Description
1,2,3,4,5,6	NC
7	CAN_H
8	CAN_L

Communication port battery to battery

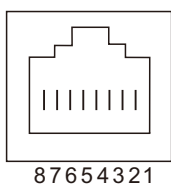

LINK-IN/OUT PIN MAP





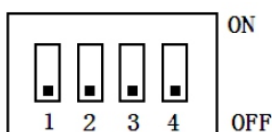

RJ45 PIN	Description
1,2,3,4,5,6	NC
7	RS485-2_A
8	RS485-2_B

ADD Switch



ADD	1#	1#	1#	1#	Remark
0	OFF	OFF	OFF	OFF	Pack 0, Default
1	ON	OFF	OFF	OFF	Pack 1, Master Battery
2	OFF	ON	OFF	OFF	Pack 2
3	ON	ON	OFF	OFF	Pack 3
4	OFF	OFF	ON	OFF	Pack 4
5	ON	OFF	ON	OFF	Pack 5
6	OFF	ON	ON	OFF	Pack 6
7	ON	ON	ON	OFF	Pack 7
8	OFF	OFF	OFF	ON	Pack 8
9	ON	OFF	OFF	ON	Pack 9
10	OFF	ON	OFF	ON	Pack 10
11	ON	ON	OFF	ON	Pack 11
12	OFF	OFF	ON	ON	Pack 12
13	ON	OFF	ON	ON	Pack 13
14	OFF	ON	ON	ON	Pack 14
15	ON	ON	ON	ON	Pack 15

LED Indicator Description

Status	Nominal Warning Protection	RUN	ALM	SOC				Description
								
Shut down	Dormancy	OFF	OFF	OFF	OFF	OFF	OFF	
Standby	Nominal	Flash 1	OFF	Follow module capacity				Standby
	Warning	Flash 1	Flash 3	Follow module capacity				Module at low voltage
Charge	Nominal	ON	OFF	Follow module capacity				
	Warning	ON	Flash 3	Follow module capacity				
	Over-charge Protection	ON	OFF	ON	ON	ON	ON	LED turn to standby if no power supply
	Temperature, over-current, Failure protection	OFF	OFF	OFF	OFF	OFF	OFF	Stop charging
Discharge	Nominal	ON	OFF	Follow module capacity				
	Warning	ON	Flash 3	Follow module capacity				
	Under voltage Protection	OFF	OFF	OFF	OFF	OFF	OFF	Stop discharging
	Temperature, over-current, short circuit, failure protection	OFF	ON	OFF	OFF	OFF	OFF	Stop discharging
Failure		OFF	ON	OFF	OFF	OFF	OFF	Stop charging and discharging

Note:

Flash 1: light 0.25s/off 3.75s

Flash 2: light 0.5s/ off 0.5s

Flash 3: light 0.5s / off 1.5s

ON/OFF Button

OFF mode

During in transport, BMS ON/OFF button is at OFF status. it will turn off the BMS power supply.

ON mode

By press ON/OFF button to active BMS to enter into working mode, if the MCB is also ON, the battery voltage will can be measured by terminal.

Even if the button is at ON mode, The BMS will enter into dormancy mode after 24 hours when there are no charge, no discharge and no communication. it can be activated again by charge or communication or repress ON/OFF button.

History Record

The BMS can restore 500 logs about historical alarm / protection data, the logs can be read by PC software.

BMS Parameters

Note: For 48V battery, it's 15 cells in series, for 51.2V, it's 16 cells in series.

S/N	Parameters	Default Setting	Adjustable or not	Remark
1	Cell Over-voltage protection	Cell OV alarm	3500mV	Adjustable
		Cell OV protection	3650mV	Adjustable
		Delay time	1.0S±0.5S	Adjustable
	Cell OV protection release	Release voltage	3380mV	Adjustable
		Discharge release	Discharge current > 1A	
2	Cell Low-voltage protection	Cell LV alarm	2800mV	Adjustable
		Cell LV protection	2500mV	Adjustable
		Delay time	1S	Adjustable
	Cell LV protection release	Release voltage	2900mV	Adjustable
		Charge release	connect to charger	
3	System Over-voltage protection	System OV alarm	3.5V*Cells series	Adjustable
		System OV protection	3.6V*Cells series	Adjustable
		Delay time	1.0S	Adjustable
	System OV protection release	Release voltage	3.38V*Cells series	Adjustable
		Discharge release	Discharge current > 1A	
4	System Low-voltage protection	System LV alarm	2.9V*Cells series	Adjustable
		System LV protection	2.8V*Cells series	Adjustable
		Delay time	1S	Adjustable
	System LV protection release	Release voltage	2.9V*Cells series	Adjustable
		Charge release	connect to charger	
5	Charge Over-current protection	OC alarm	105A	Adjustable
		OC protection	110A	Adjustable
		Delay time	1.0S	Adjustable
	Charge OC protection release	Automatic release	1min automatic release	
		Discharge release	discharge current > 1A	

S/N	Parameters	Default Setting	Adjustable or not	Remark	
6	OC Alarm-1	110A	Adjustable		
	Discharge Over-current protection	OC protection	120A	Adjustable	
		Delay time	1.0S	Adjustable	
		Automatic release	It will be automatically released after 1min. If it repeat 10 times, the state will be locked.		
	Discharge Over-current protection release	Discharge release			
		Charge release	charge current > 1A		
8	Short circuit protection	Short circuit protection	Yes		
	Release voltage	Charge the battery			
		Remove the load			
9	MOS HT alarm	90°C	Adjustable		
	MOS HT protection	110°C	Adjustable		
	MOS protection release	90°C	Adjustable		
10	Cell temperature	Charge low temperature alarm	0°C	Adjustable	
		Charge low temperature protection	-5°C	Adjustable	
		Charge low temperature protection release	0°C	Adjustable	
		Charge high temperature alarm	60°C	Adjustable	
		Charge high temperature protection	65°C	Adjustable	
		Charge high temperature protection release	60°C	Adjustable	
		Discharge low temperature alarm	-15°C	Adjustable	
		Discharge low temperature protection	-20°C	Adjustable	
		Discharge low temperature protection release	-15°C	Adjustable	
		Discharge high temperature alarm	65°C	Adjustable	
Discharge high temperature protection	70°C	Adjustable			
Discharge high temperature protection release	60°C	Adjustable			

S/N	Parameters	Default Setting	Adjustable or not	Remark
11	Ambient temperature			
	Ambient low temperature alarm	-20°C	Adjustable	
	Ambient low temperature protection	-25°C	Adjustable	
	Ambient low temperature protection release	-20°C	Adjustable	
	Ambient high temperature alarm	65°C	Adjustable	
	Ambient high temperature protection	70°C	Adjustable	
	Ambient high temperature protection release	65°C	Adjustable	

Transportation and storage

Transportation requirement

The product passes the certifications of the UN38.3 (UN38.3: Section 38.3 of the sixth Revised Edition of the Recommendations on the Transport of Dangerous Goods, Manual of Tests and Criteria) and SN/T 0370.2-2009 (Part 2: Performance Test of the Rules for the Inspection of Packaging for Exporting Dangerous Goods). This product belongs to class 9 dangerous goods.

The SOC is 50% when shipped from factory.

The product can be delivered to the site directly and transported by land and water. The packing case must be secured for transportation, compliant with related national standards,

and printed with marks such as anti-collision and moisture prevention. Dispose of waste ESMS in strict accordance with local laws and regulations.

Protect the packing case with the product from the following situations:

- Being dampened by rains, snows, or falling into water
- Falling or mechanical impact
- Being upside-down or tilted

Storage

The rack type Li-ion battery can be stored in an environment with temperatures between -40°C and +60°C and between 10% and 90% relative humidity, non-condensing. For long storage periods at 25°C, charge the battery every 6 months. For temperatures above 40°C, charge the battery every quarter.

- Do not store the Li-ion battery at temperatures above 60°C.
- Keep away from heat sources (such as a heater)

Communication with different inverter

Syscom RESS rack type li-ion battery BMS support to do communication with below inverters. This chapter mainly introduce the communication cable connection and BMS software configuration.

SN	Inverter Brand	Adaption Series	Communication
1	Victron	CCGX- VE-CAN	CAN
2	SMA	SUNNY ISLAND Series	CAN
3	Megarevo	REVO Series	CAN
4	MUST	Solar Inverter 2KW-5.5KW	CAN
5	Voltronic	Axpert Series	RS485
6	Growatt	SPF *** TL, ES, Series.	RS485
7	OPTI	SP5000 Handy Plus	RS485
8	DEYE	SUN-3K/3.6K-SG04LP1	RS485
9	INHENERGY	HI-**-SL Series	RS485
10	Afore	HNS3000-6000HS	RS485
11	Phocos	Any-Grid PSW-H	RS485

Note: The list of inverter will renew by the BMS software update, the newest inverter list will shown on BMS PC software.

Communication cable

The accessories communication cable is standard T-568B CAT5-e cable. it can be used for battery-battery internal communication and inverter CAN (Victron), RS485 (Growatt, DEYE, INHENERGY), for other brand inverter, it needs to modify communication cable according to PINOUT of inverter.

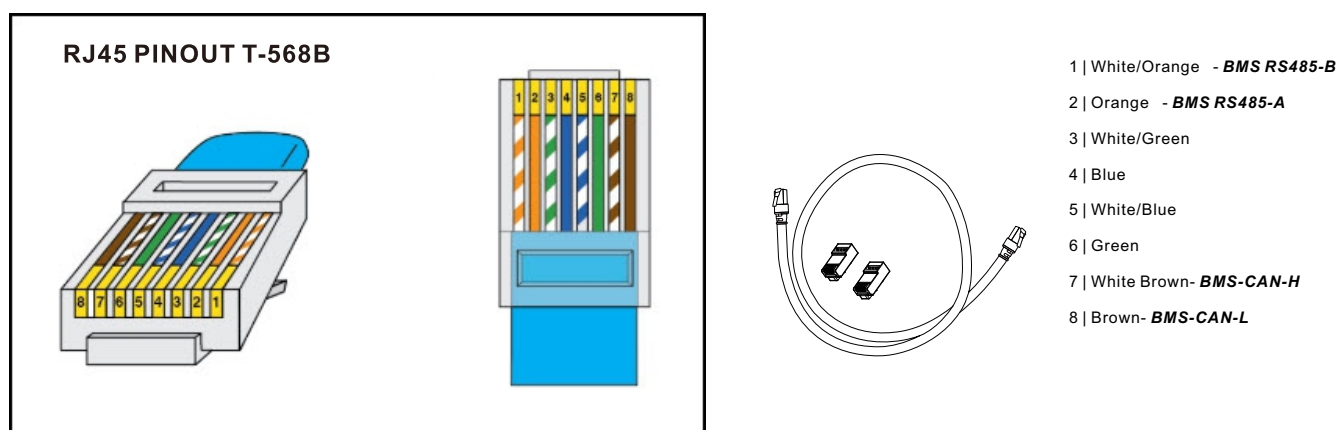

BMS RS485 and CAN Port, Major inverter BMS Port.

PIN	BMS		CAN				RS485					
	RS485	CAN	Victron	SMA	Megarevo	MUST	Growatt	Voltronic	DEYE	Afore	Phocos	INHENERGY
1	485_B	NC	NET-C/V-	Sync1-reserved	/	485_B	485_B	/	485_B	Meter 485A	232_RX	485_B
2	485_A	NC	NET-S/V+	CAN_GND	/	485_A	485_A	/	485_A	Meter 485B	232_TX	486_A
3	NC	NC	NET-C/V-	SYNC_H	/	GND	NC	485_B	/	BAT 485A	485_B	GND_S
4	NC	NC	NC	CAN_H	CAN_H	/	NC	/	CAN_H	BAT CANH	+12Vdc	CAN_H
5	NC	NC	NC	CAN_L	CAN_L	CAN_L	NC	485_A	CAN_L	BAT CANL	485_A	CAN_L
6	NC	NC	NET-S/V+	SYNC_L	485_GND	CAN_H	NC	/	485_GND	BAT 485B	CAN_H	NTC.BAT
7	NC	CAN-H	CAN-H	Sync7-Reserved	485_A	/	NC	/	485_A	CTU	CAN_L	WAKE-
8	NC	CAN-L	CAN-L	Sync8-Reserved	485_B	/	NC	/	485_B	CTN	GND	WAKE+

System cable connection

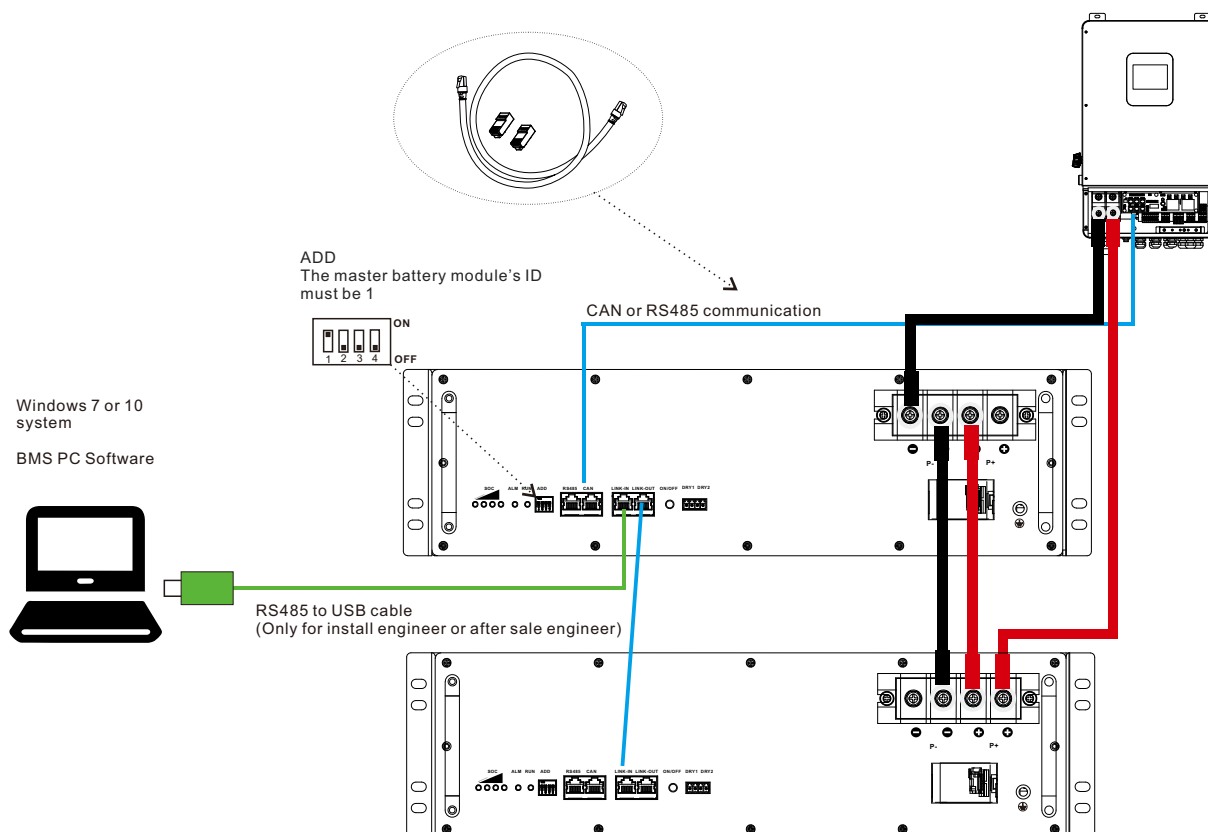

Charging Batteries

The constant current (CC) charger is recommended strongly.

The charge voltage and current setting can refer to below table:

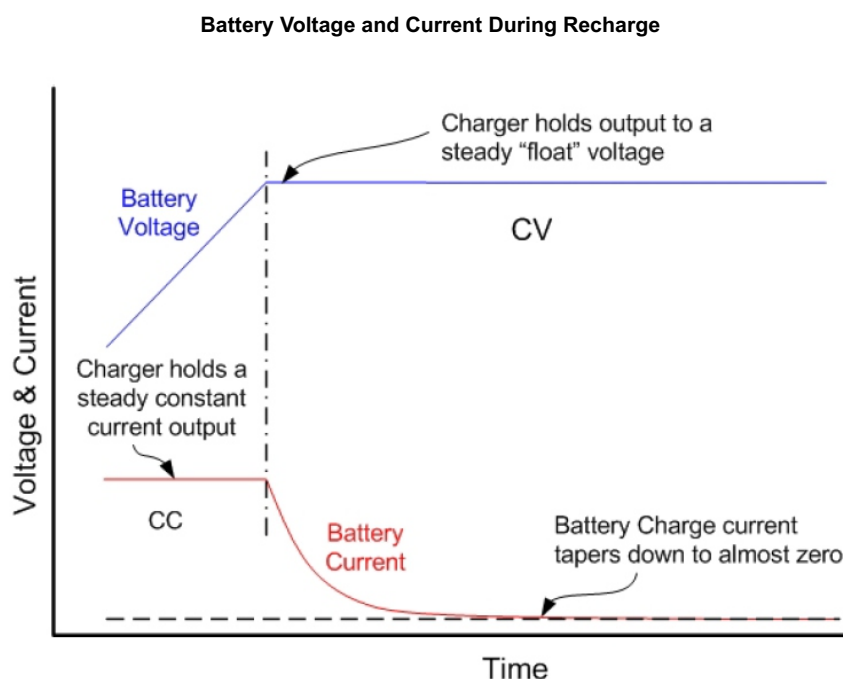

- If there are communication between battery and inverter, the BMS will automatic request charge and discharge parameters from inverter,
- If there are no communication between battery and inverter, setting charge and discharge parameters on inverter.

Recommended setting for 48V battery:

Equalized charging voltage: 52.5Vd

Float charging voltage: 50.5Vdc

Charge current: 0.5C

End of discharge voltage: 45Vdc

Recommended setting for 51.2V battery:

Equalized charging voltage: 56.0Vd

Float charging voltage: 53.9Vdc

Charge current: 0.5C

End of discharge voltage: 48Vdc

BMS PC Software Operation

1. Download BMS PC software and Unzip to a local folder.

http://120.27.63.138:8181/docs/rack_48v/software

2. Connect battery LINK-IN port to computer by RS485 to USB equipment:

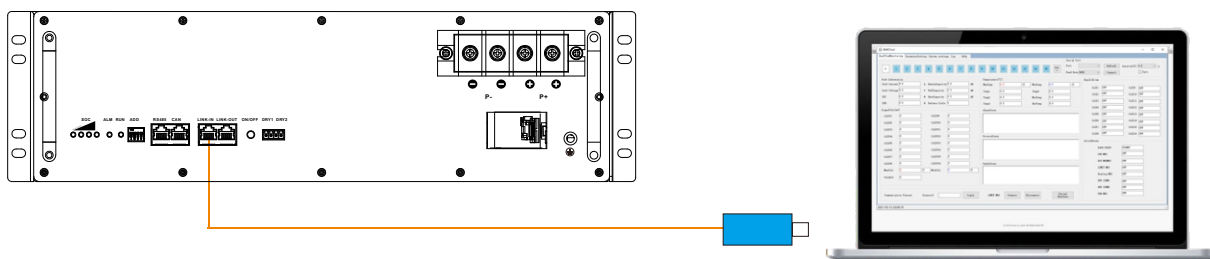

3. Check the battery ADD and make sure the ID=1



4. Double click “BMSTool.exe” to run BMS PC software.

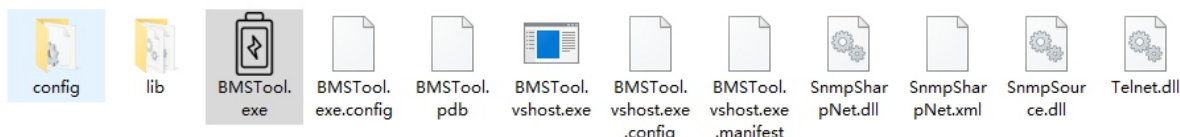

Battery ADD **If RS485 to USB device is connected well, the serial port will be listed**

3. Click “Connect”, the BMS detail information will be listed

The screenshot shows the BMSTool software interface with several key sections highlighted by red boxes:

- Pack Information:** Displays Pack Current (0.0 A), Pack Voltage (48.8 V), SOC (21.0%), SOH (100.0%), and Battery Cycle (1).
- Temperature (C):** Shows MaxTemp (29.0), Min Temp (28.4), and individual temperatures for Temp 1-4 and Env Temp (31.0).
- Cell Voltage (mV):** Lists voltages for 16 individual cells (V1-V16) and MaxVolt (3252 mV).
- Alarm Status:** Shows 'No Alarm', 'Protect Status: No Protect', and 'Fault Status: No Fault'.
- SwitchStatus:** Includes controls for PACK STATUS (STANDBY), CHG MOS, DSG MOS, LIMIT MOS, HEATING MOS, DRY CONN1, DRY CONN2, and PRE MOS.

Battery information:
Total current, Total voltage,
SOC, SOH, Remain capacity,
Rated capacity, Cycle times.

Cells information:
Cell voltage

Alarm, Protection, Fault
information

Temperature information:
Cell temperature
Environment temperature
BMS temperature (MOS)

Note:

The Parameter setting change must be carried out by a professional engineer.

Writer new
parameters

Check default BMS
parameters setting

The screenshot shows the 'ParameterSetting' tab in the BMSTool software. It features a grid of settings for various protection and alarm functions, each with a checkbox and numerical input fields:

- Pack OV Alarm Protect:** Pack OV Alarm (V), Pack OV Protect (V), Pack OVP Release (V), Pack OVP Delay Time (mS).
- Cell OV Alarm Protect:** Cell OV Alarm (V), Cell OV Protect (V), Cell OVP Release (V), Cell OVP Delay Time (mS).
- Pack UV Alarm Protect:** Pack UV Alarm (V), Pack UV Protect (V), Pack UVP Release (V), Pack UVP Delay Time (mS).
- Cell UV Alarm Protect:** Cell UV Alarm (V), Cell UV Protect (V), Cell UVP Release (V), Cell UP Delay Time (mS).
- CHG OC Alarm Protect:** CHG OC Alarm (A), CHG OC Protect (A), CHG OC Delay Time (mS).
- CHG OT Alarm Protect:** CHG OT Alarm (°C), CHG OT Protect (°C), CHG OTP Release (°C).
- DSG OT Alarm Protect:** DSG OT Alarm (°C), DSG OT Protect (°C), DSG OTP Release (°C).
- CHG UT Alarm Protect:** CHG UT Alarm (°C), CHG UT Protect (°C), CHG UTP Release (°C).
- DSG OC Alarm Protect:** DSG OC Alarm (A), DSG OC 1 Protect (A), DSG OC 1 Delay Time (mS), DSG OC 2 Protect (A), DSG OC 2 Delay Time (mS).
- DHG UT Alarm Protect:** DHG UT Alarm (°C), DHG UT Protect (°C), DHG UTP Release (°C).
- MOS OT Alarm Protect:** MOS OT Alarm (°C), MOS OT Protect (°C), MOS OTP Release (°C).
- ENV OT Alarm Protect:** ENV OT Alarm (°C), ENV OT Protect (°C), ENV OTP Release (°C).
- ENV UT Alarm Protect:** ENV UT Alarm (°C), ENV UT Protect (°C), ENV UTP Release (°C).
- Balance Threshold (mV):** Balance Δ Vcell (mV).
- Sleep Vcell (V):** Delay Time (s), SCP Delay Time (uS), SOC Low Alarm (%).

At the bottom left, the date and time are displayed as 2021-12-22 09:09:10.

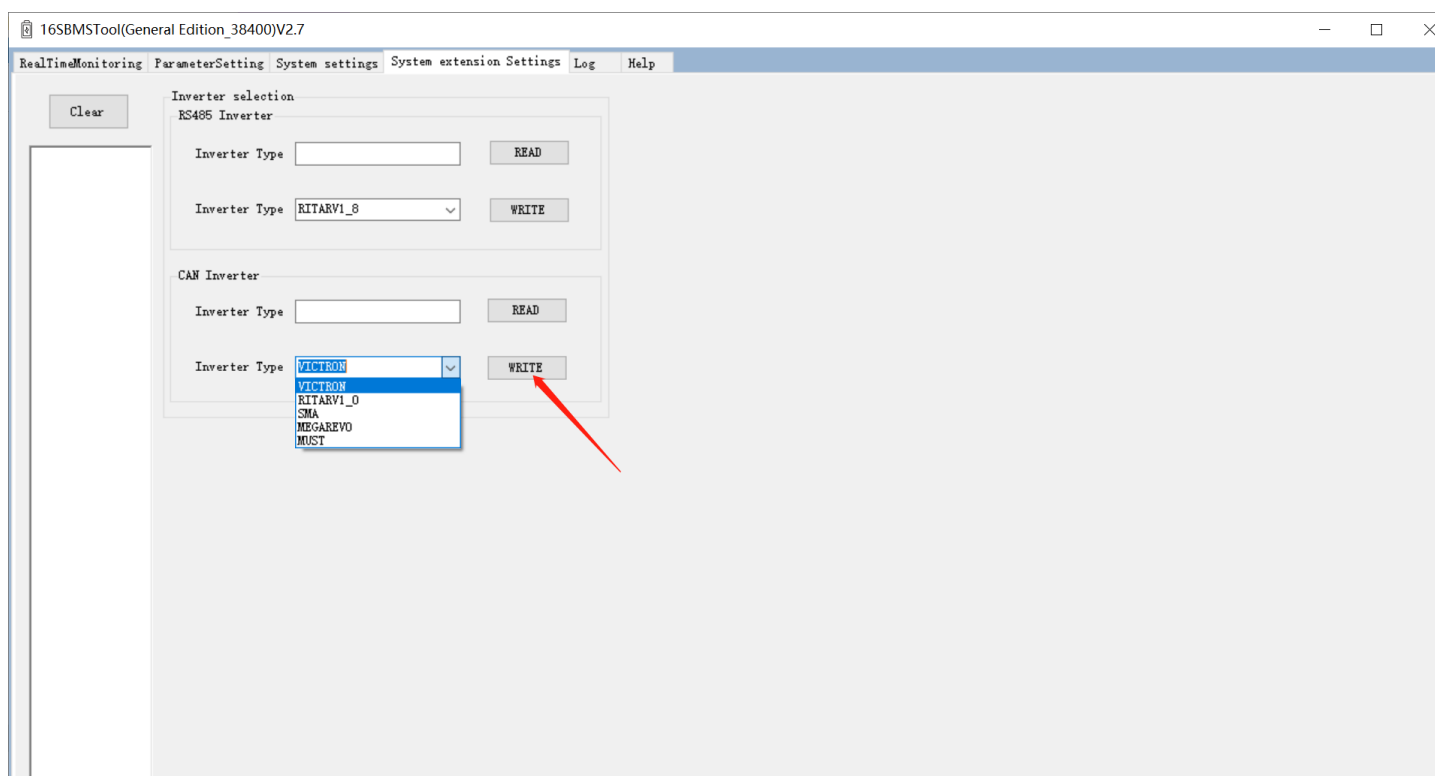

Note:

The Parameter setting change must be carried out by a professional engineer.