

Honeywell



SK-PS6 & SK-PS10

Power Supplies

Instruction Manual

Fire Alarm & Emergency Communication System Limitations

While a life safety system may lower insurance rates, it is not a substitute for life and property insurance!

An automatic fire alarm system—typically made up of smoke detectors, heat detectors, manual pull stations, audible warning devices, and a fire alarm control panel (FACP) with remote notification capability—can provide early warning of a developing fire. Such a system, however, does not assure protection against property damage or loss of life resulting from a fire.

An emergency communication system—typically made up of an automatic fire alarm system (as described above) and a life safety communication system that may include an autonomous control unit (ACU), local operating console (LOC), voice communication, and other various interoperable communication methods—can broadcast a mass notification message. Such a system, however, does not assure protection against property damage or loss of life resulting from a fire or life safety event.

The Manufacturer recommends that smoke and/or heat detectors be located throughout a protected premises following the recommendations of the current edition of the National Fire Protection Association Standard 72 (NFPA 72), manufacturer's recommendations, State and local codes, and the recommendations contained in the Guide for Proper Use of System Smoke Detectors, which is made available at no charge to all installing dealers. This document can be found at <http://www.systemsensor.com/appguides/>. A study by the Federal Emergency Management Agency (an agency of the United States government) indicated that smoke detectors may not go off in as many as 35% of all fires. While fire alarm systems are designed to provide early warning against fire, they do not guarantee warning or protection against fire. A fire alarm system may not provide timely or adequate warning, or simply may not function, for a variety of reasons:

Smoke detectors may not sense fire where smoke cannot reach the detectors such as in chimneys, in or behind walls, on roofs, or on the other side of closed doors. Smoke detectors also may not sense a fire on another level or floor of a building. A second-floor detector, for example, may not sense a first-floor or basement fire.

Particles of combustion or "smoke" from a developing fire may not reach the sensing chambers of smoke detectors because:

- Barriers such as closed or partially closed doors, walls, chimneys, even wet or humid areas may inhibit particle or smoke flow.
- Smoke particles may become "cold," stratify, and not reach the ceiling or upper walls where detectors are located.
- Smoke particles may be blown away from detectors by air outlets, such as air conditioning vents.
- Smoke particles may be drawn into air returns before reaching the detector.

The amount of "smoke" present may be insufficient to alarm smoke detectors. Smoke detectors are designed to alarm at various levels of smoke density. If such density levels are not created by a developing fire at the location of detectors, the detectors will not go into alarm.

Smoke detectors, even when working properly, have sensing limitations. Detectors that have photoelectronic sensing chambers tend to detect smoldering fires better than flaming fires, which have little visible smoke. Detectors that have ionizing-type sensing chambers tend to detect fast-flaming fires better than smoldering fires. Because fires develop in different ways and are often unpredictable in their growth, neither type of detector is necessarily best and a given type of detector may not provide adequate warning of a fire.

Smoke detectors cannot be expected to provide adequate warning of fires caused by arson, children playing with matches (especially in bedrooms), smoking in bed, and violent explosions (caused by escaping gas, improper storage of flammable materials, etc.).

Heat detectors do not sense particles of combustion and alarm only when heat on their sensors increases at a predetermined rate or reaches a predetermined level. Rate-of-rise heat detectors may

year by a qualified fire protection specialist. Heat detectors are designed to protect property, not life.

IMPORTANT! Smoke detectors must be installed in the same room as the control panel and in rooms used by the system for the connection of alarm transmission wiring, communications, signaling, and/or power. If detectors are not so located, a developing fire may damage the alarm system, compromising its ability to report a fire.

Audible warning devices such as bells, horns, strobes, speakers and displays may not alert people if these devices are located on the other side of closed or partly open doors or are located on another floor of a building. Any warning device may fail to alert people with a disability or those who have recently consumed drugs, alcohol, or medication. Please note that:

- An emergency communication system may take priority over a fire alarm system in the event of a life safety emergency.
- Voice messaging systems must be designed to meet intelligibility requirements as defined by NFPA, local codes, and Authorities Having Jurisdiction (AHJ).
- Language and instructional requirements must be clearly disseminated on any local displays.
- Strobes can, under certain circumstances, cause seizures in people with conditions such as epilepsy.
- Studies have shown that certain people, even when they hear a fire alarm signal, do not respond to or comprehend the meaning of the signal. Audible devices, such as horns and bells, can have different tonal patterns and frequencies. It is the property owner's responsibility to conduct fire drills and other training exercises to make people aware of fire alarm signals and instruct them on the proper reaction to alarm signals.
- In rare instances, the sounding of a warning device can cause temporary or permanent hearing loss.

A life safety system will not operate without any electrical power. If AC power fails, the system will operate from standby batteries only for a specified time and only if the batteries have been properly maintained and replaced regularly.

Equipment used in the system may not be technically compatible with the control panel. It is essential to use only equipment listed for service with your control panel.

Alarm Signaling Communications:

- **IP connections** rely on available bandwidth, which could be limited if the network is shared by multiple users or if ISP policies impose restrictions on the amount of data transmitted. Service packages must be carefully chosen to ensure that alarm signals will always have available bandwidth. Outages by the ISP for maintenance and upgrades may also inhibit alarm signals. For added protection, a backup cellular connection is recommended.
- **Cellular connections** rely on a strong signal. Signal strength can be adversely affected by the network coverage of the cellular carrier, objects and structural barriers at the installation location. Utilize a cellular carrier that has reliable network coverage where the alarm system is installed. For added protection, utilize an external antenna to boost the signal.
- **Telephone lines** needed to transmit alarm signals from a premise to a central monitoring station may be out of service or temporarily disabled. For added protection against telephone line failure, backup alarm signaling connections are recommended.

The most common cause of life safety system malfunction is inadequate maintenance. To keep the entire life safety system in excellent working order, ongoing maintenance is required per the manufacturer's recommendations, and UL and NFPA standards. At a minimum, the requirements of NFPA 72 shall be followed. Environments with large amounts of dust, dirt, or high air velocity require more frequent maintenance. A maintenance agreement should be arranged through the local manufacturer's representative. Maintenance should be scheduled as required by National and/or local fire codes and should be performed by authorized professional

Installation Precautions

Adherence to the following will aid in problem-free installation with long-term reliability:

WARNING - Several different sources of power can be connected to the fire alarm control panel. Disconnect all sources of power before servicing. Control unit and associated equipment may be damaged by removing and/or inserting cards, modules, or interconnecting cables while the unit is energized. Do not attempt to install, service, or operate this unit until manuals are read and understood.

CAUTION - System Re-acceptance Test after Software

Changes: To ensure proper system operation, this product must be tested in accordance with NFPA 72 after any programming operation or change in site-specific software. Re-acceptance testing is required after any change, addition or deletion of system components, or after any modification, repair or adjustment to system hardware or wiring. All components, circuits, system operations, or software functions known to be affected by a change must be 100% tested. In addition, to ensure that other operations are not inadvertently affected, at least 10% of initiating devices that are not directly affected by the change, up to a maximum of 50 devices, must also be tested and proper system operation verified.

This system meets NFPA requirements for operation at 0-49° C/ 32-120° F and at a relative humidity 93% ± 2% RH (non-condensing) at 32°C ± 2°C (90°F ± 3°F). However, the useful life of the system's standby batteries and the electronic components may be adversely affected by extreme temperature ranges and humidity. Therefore, it is recommended that this system and its peripherals be installed in an environment with a normal room temperature of 15-27° C/60-80° F.

Verify that wire sizes are adequate for all initiating and indicating device loops. Most devices cannot tolerate more than a 10% I.R. drop from the specified device voltage.

Like all solid state electronic devices, this system may operate erratically or can be damaged when subjected to lightning induced transients. Although no system is completely immune from lightning transients and interference, proper grounding will reduce susceptibility. Overhead or outside aerial wiring is not recommended, due to an increased susceptibility to nearby lightning strikes. Consult with the Technical Services Department if any problems are anticipated or encountered.

Disconnect AC power and batteries prior to removing or inserting circuit boards. Failure to do so can damage circuits.

Remove all electronic assemblies prior to any drilling, filing, reaming, or punching of the enclosure. When possible, make all cable entries from the sides or rear. Before making modifications, verify that they will not interfere with battery, transformer, or printed circuit board location.

Do not tighten screw terminals more than 9 in-lbs. Over-tightening may damage threads, resulting in reduced terminal contact pressure and difficulty with screw terminal removal.

This system contains static-sensitive components. Always ground yourself with a proper wrist strap before handling any circuits so that static charges are removed from the body. Use static suppressive packaging to protect electronic assemblies removed from the unit.

Units with a touchscreen display should be cleaned with a dry, clean, lint free/microfiber cloth. If additional cleaning is required, apply a small amount of Isopropyl alcohol to the cloth and wipe clean. Do not use detergents, solvents, or water for cleaning. Do not spray liquid directly onto the display.

Follow the instructions in the installation, operating, and programming manuals. These instructions must be followed to avoid damage to the control panel and associated equipment. FACP operation and reliability depend upon proper installation.

Precau-D2-11-2017

FCC Warning

WARNING: This equipment generates, uses, and can radiate radio frequency energy and if not installed and used in accordance with the instruction manual may cause interference to radio communications. It has been tested and found to comply with the limits for class A computing devices pursuant to Subpart B of Part 15 of FCC Rules, which is designed to provide reasonable protection against such interference when devices are operated in a commercial environment. Operation of this equipment in a residential area is likely to cause interference, in which case the user will be required to correct the interference at his or her own expense.

Canadian Requirements

This digital apparatus does not exceed the Class A limits for radiation noise emissions from digital apparatus set out in the Radio Interference Regulations of the Canadian Department of Communications.

Le présent appareil numérique n'émet pas de bruits radioélectriques dépassant les limites applicables aux appareils numériques de la classe A prescrites dans le Règlement sur le brouillage radioélectrique édicté par le ministère des Communications du Canada.

eVance®, Flexput®, Honeywell®, JumpStart®, Silent Knight®, and SWIFT® are registered trademarks of Honeywell International Inc. Microsoft® and Windows® are registered trademarks of the Microsoft Corporation. Chrome™ and Google™ are trademarks of Google Inc. Firefox® is a registered trademark of The Mozilla Foundation.

©2021. All rights reserved. Unauthorized use of this document is strictly prohibited.

Software Downloads

In order to supply the latest features and functionality in fire alarm and life safety technology to our customers, we make frequent upgrades to the embedded software in our products. To ensure that you are installing and programming the latest features, we strongly recommend that you download the most current version of software for each product prior to commissioning any system. Contact Technical Support with any questions about software and the appropriate version for a specific application.

Documentation Feedback

Your feedback helps us keep our documentation up-to-date and accurate. If you have any comments or suggestions about our online Help or printed manuals, you can email us.

Please include the following information:

- Product name and version number (if applicable)
- Printed manual or online Help
- Topic Title (for online Help)
- Page number (for printed manual)
- Brief description of content you think should be improved or corrected
- Your suggestion for how to correct/improve documentation

Send email messages to:

FireSystems.TechPubs@honeywell.com

Please note this email address is for documentation feedback only. If you have any technical issues, please contact Technical Services.



This symbol (shown left) on the product(s) and / or accompanying documents means that used electrical and electronic products should not be mixed with general household waste. For proper treatment, recovery and recycling, contact your local authorities or dealer and ask for the correct method of disposal.

Electrical and electronic equipment contains materials, parts and substances, which can be dangerous to the environment and harmful to human health if the waste of electrical and electronic equipment (WEEE) is not disposed of correctly.

Table of Contents

Section 1: System Overview	8
1.1: General	8
1.2: Features	8
1.3: Specifications	8
1.4: Open/Short/Ground Fault Trip Values in Standby	9
1.5: Switch SW1 - Ground Fault Detection	9
1.6: Applications	11
1.7: Start-up Procedure	11
Section 2: Installation	12
2.1: Backbox Mounting	12
2.2: NAC Circuit Wiring	13
2.2.1: Class B	13
2.2.2: ZNAC-PS Class A Option Module	13
2.3: Addressable Module Mounting	14
2.4: NEC Power-limited (Class 2) Wiring Requirements	15
2.5: FACP with SK-PS Power Supply in Slave Mode	16
2.6: SK-PS Power Supply in Master Mode Connected to FACP	16
2.7: Connecting to an External Charger	17
2.7.1: CHG-120F	17
2.7.2: CHG-75	17
2.8: Cascading Multiple Units	18
Section 3: Programming Options	20
3.1: S1 Global Options DIP Switch	21
3.1.1: Global Programmable Features Description	21
Input Debounce/Dejitter/Delay	21
Command Input #1	22
Charger Enable/Disable	22
AC Loss Door Holder Dropout Timer	22
AC Fail Indication Delay	22
Special Operating Modes	22
3.2: Output Circuit Control DIP Switch Settings	23
3.2.1: Output Circuit Programmable Features Description	23
Command Inputs/NAC Circuits	23
Unused Outputs	24
Remote Supply with Resettable and Non-resettable Power	24
Door Holder	24
Synchronization Mode - Master/Slave	24
Master Mode - Selective Silence	25
Command Input #1 - Normal/Sync Mode of Operation	25
Class A Wiring	26
Section 4: LED Indicators	27
Section 5: Trouble Supervision	29
5.1: Trouble Supervision Using Input Circuits	29
5.2: Trouble Relay	29
5.3: AC Trouble Relay	29
Section 6: Power Supply Requirements	31
6.1: Overview	31
6.2: Calculating the AC Branch Circuit	31
6.3: Calculating the System Current Draw	31
6.3.1: Overview	31
6.3.2: How to Calculate System Current Draw	32
6.4: Selecting and Locating Batteries	32
6.4.1: NFPA Battery Requirements	32
6.4.2: Maximum Battery Standby Load	33
Section 7: Testing and Maintenance	33
7.1: Periodic Testing and Service	33
7.2: Battery Checks and Maintenance	33

Appendix A: Wire Requirements..... 34

Appendix B: Application Examples 35

 B.1: Controlling NACs For Selective Silence Operation Using a Control Module35

 B.2: Controlling NACs For Sync Follower Operation Using a Control Module36

 B.3: Controlling NACs, Aux Power, or Door Holders Using a Control Module37

 B.4: Controlling NACs, Aux Power, and Door Holders with NAC Sync38

 B.5: Controlling all Three Inputs with One Control Module.....39

 B.6: AC Trouble Reporting with a Conventional FACP.....40

Index 41

It is imperative that the installer understand the requirements of the Authority Having Jurisdiction (AHJ) and be familiar with the standards set forth by the following regulatory agencies:

- Underwriters Laboratories Standards
- NFPA 72 National Fire Alarm Code

Before proceeding, the installer should be familiar with the following documents.



NFPA Standards

NFPA 72 National Fire Alarm Code
NFPA 70 National Electrical Code



Underwriters Laboratories Documents:

UL 464 Audible Signaling Appliances
UL 864 Standard for Control Units for Fire Protective Signaling Systems
UL 1638 Visual Signaling Appliances
UL 1971 Signaling Devices for Hearing Impaired
UL 2572 Standard for Mass Notification Systems

Other:

NEC Article 250 Grounding
NEC Article 300 Wiring Methods
NEC Article 760 Fire Protective Signaling Systems
Applicable Local and State Building Codes
Requirements of the Local Authority Having Jurisdiction (LAHJ)

Other Silent Knight Documents:

Device Compatibility Document	Document #52612
CHG-75 Manual	Document #51315
CHG-120F Manual	Document #50888

This product has been certified to comply with the requirements in the Standard for Control Units and Accessories for Fire Alarm Systems, UL 864, 10th Edition. Operation of this product with products not tested for UL 864, 9th/10th Edition has not been evaluated. Such operation requires the approval of the local Authority Having Jurisdiction (AHJ).



This symbol (shown left) on the product(s) and / or accompanying documents means that used electrical and electronic products should not be mixed with general household waste. For proper treatment, recovery and recycling, contact your local authorities or dealer and ask for the correct method of disposal.

Electrical and electronic equipment contains materials, parts and substances, which can be dangerous to the environment and harmful to human health if the waste of electrical and electronic equipment (WEEE) is not disposed of correctly.

Section 1: System Overview

The SK-PS6 is a 6 amp and the SK-PS10 is a 10 amp remote power supply with battery charger. Both models provide ADA compatible strobe synchronization and a filtered 24 VDC output that can be configured to drive five (6 amp model) or seven (10 amp model) Class B NACs (Notification Appliance Circuits). NAC circuits can be configured for Class A wiring with the optional ZNAC-PS Class A converter module. NAC output circuits may be configured as 24 VDC resettable or non-resettable power outputs, or Class D door holder outputs. The input circuits, which control the power supply operation, are triggered by the reverse polarity of a NAC or by a 12 VDC or 24 VDC power source. The SK-PS power supplies are compatible with 12 VDC and 24 VDC control panels.

1.1 General

SK-PS power supplies can be used as remotely mounted power supplies and battery chargers to power non-coded or coded NACs. The Main FACP (Fire Alarm Control Panel) NAC(s) is connected to the remote power supply input circuit(s). When the command input circuit activates due to reverse polarity of the NAC from the FACP, the power supply will activate its Notification Appliance Circuits.

During the inactive or non-alarm state, the power supply supervises its NAC field wiring for short and open conditions. AC fail, battery, charger and ground fault troubles will also be monitored by the power supply and will activate the AC Fail and Battery Fault relay, respectively. If a NAC fault is detected, the input end-of-line will open to indicate the fault to the main panel.

If an alarm condition occurs and the NAC is activated, the supervision is disabled and the Notification Appliance Circuit is no longer supervised (except for shorts). Supervision of other power supply faults such as low battery, overcharged battery, ground fault, and battery charger trouble will continue and will be monitored by their respective trouble relays.

1.2 Features

- Self-contained in a lockable cabinet
- 24 VDC remote power supply
- Outputs are completely power-limited (Class 2)
- Two (SK-PS6) or three (SK-PS10) optically-isolated input/command circuits, compatible with 12 VDC and 24 VDC control panel NACs
- Five (SK-PS6) or seven (SK-PS10) output circuits:
 - Fully filtered power
 - Five or seven 24 VDC Class B NACs
 - Optional ZNAC-PS Class A converter module for conversion to Class A NACs
 - Alternatively, all output circuits may be configured as 24 VDC special application power outputs or Class D door holder power outputs
 - Output circuits may be configured as resettable or non-resettable
- Individual NAC Power (red) and Trouble (yellow) LEDs for each output
- Maximum current available:
 - SK-PS6: TB8-TB9 – 1A Regulated, 3A special applications; TB10-TB12 – 0.3A Regulated, 3A special applications
 - SK-PS10: TB8-TB11 – 1.5A Regulated, 3A special applications; TB12-TB14 – 0.3A Regulated, 3A special applications
- Maximum total current available (alarm and standby):
 - 6.0 amps for SK-PS6 alarm; 3.0 amps standby
 - 10.0 amps for SK-PS10 alarm; 3.0 amps standby
- Integral supervised battery charger for lead acid batteries only
- Capable of charging 7.0 AH - 33.0 AH (Amp Hour) batteries (cabinet fits 7 or 18 AH batteries)
- Fully supervised power supply, battery and NACs
- Selectable Strobe Synchronization for NACs (System Sensor, Gentex, Wheelock, and Amseco)
- Coded signal synchronization
- Removable terminal blocks for field wiring capable of accepting 12 - 18 AWG wire
- Selectable Ground Fault detection by switch SW1
- LED trouble diagnostics and history
- Power supply trouble and AC Loss Form-C relay contacts (fail-safe)
- Optional delay of AC loss reporting for 0, 2, 12, or 30 hours
- Mounting location for optional addressable module
- Up to four PS Series units can be cascaded

1.3 Specifications

Refer to Figure 1.1 on page 10 for terminal locations.



NOTE: The SK-PS6 uses the same PCB layout as the SK-PS10, however some terminals will be depopulated, leaving the SK-PS6 with five output circuits and two input circuits.

Primary AC Power - TB4

- SK-PS6: 120 VAC, 50/60 Hz, 5.0 amps maximum
- SK-PS10: 120 VAC, 50/60 Hz, 6.2 amps maximum
- Wire size: #12-14 AWG wire with 600V insulation

Command Input Circuits - TB5, TB6, TB7

- Trigger Input Voltage: 9 - 32 VDC
- Input Current Draw in Alarm Polarity: 9 - 32 volts, 14.0 mA maximum per input

Output Circuits - TB8-TB14

- Supervised and power-limited
- Voltage Rating: 24 VDC filtered
- Current:
 - SK-PS6: TB8-TB9 – 1A Regulated, 3A special applications; TB10-TB12 – 0.3A Regulated, 3A special applications
 - SK-PS10: TB8-TB11 – 1.5A Regulated, 3A special applications; TB12-TB14 – 0.3A Regulated, 3A special applications
 - Maximum total alarm current for all output:
 - SK-PS6 - 6.0 amps
 - SK-PS10 - 10.0 amps
- Output Circuit Types:
 - Class B NACs (require 2k Ω - 27k Ω End-of-Line Resistors) and/or Class A NACs using the optional ZNAC-PS Class A converter module. Use Listed ELRs supplied by the FACP or compatible equipment manufacturer.
 - Resettable or non-resettable outputs for 24 VDC power outputs or Class D door holder (max ripple voltage: 780mV_{RMS})
- Refer to the *Silent Knight Device Compatibility Document #52612* for listed compatible devices.
- For wiring requirements, refer to “Wire Requirements” on page 34.

Trouble and AC Loss Relay Contact Rating - TB1-TB2

- Fail-safe Form-C relay (normally energized, transfers with loss of power)
- 4.0 amps @ 30 VDC resistive

Secondary Power (battery) Charging Circuit - TB15

- Supervised, non-power-limited
- Supports lead acid type batteries only
- Float Charge Voltage: 27.6 VDC
- Maximum Peak Charge Current: 2.47A
- Maximum Nominal Charge Current: 1.5 A
- Maximum Battery Capacity: 33.0 AH (with onboard battery charger)
- Minimum Battery Capacity: 7.0 AH



NOTE: The SK-PS only supports 7AH or 18AH batteries in the cabinet. Other battery capacities up to 33AH will not fit in the cabinet due to physical dimensions and require a separate battery cabinet.

1.4 Open/Short/Ground Fault Trip Values in Standby

Table 1.1 lists the earth fault resistance detection in standby for each applicable terminal on the FACP.

Output Circuit	Terminal	Trip Resistance (in ohms)
NAC 1-5/7	+	9.9K or lower
NAC 1-5/7	-	9.2K or lower
ZNAC-PS 1-5/7	+	9.9K or lower
ZNAC-PS 1-5/7	-	9K or lower

Table 1.1 Earth Fault Trip Values

Value of the resistance in between any circuit terminal to Earth, which will cause the Ground Fault detection, depends on the ELR chosen for inputs and output circuits. This resistance will vary from 9.9K down to 0 Ohm.

Table 1.2 lists the open/short trip values and restoral values in standby for the NAC circuits on the FACP.

Circuit	Fault	Trip Resistance (in ohms)	Restore Value
NAC 1-5/7	Short	1.6K or lower	1.7K or higher
NAC 1-5/7	Open	55K or higher	33K or lower
ZNAC-PS 1-5/7	Short	1.6K or lower	1.7K or higher
ZNAC-PS 1-5/7	Open	45K or higher	21K or lower

Table 1.2 NAC Open/Short Trip Values

1.5 Switch SW1 - Ground Fault Detection

The Ground Fault Detection circuit monitors for ground faults. Switch SW1 is located on the lower left section of the power supply circuit board. Sliding SW1 to the left will disable ground fault detection by the power supply. This should only be done if ground faults are being monitored by an FACP connected to the SK-PS power supply or in a cascading application as shown in Section 2.8 on page 18.

Note: The SK-PS6 uses the same PCB layout, however some terminals will be depopulated, leaving the SK-PS6 with five output circuits and two inputs circuits.

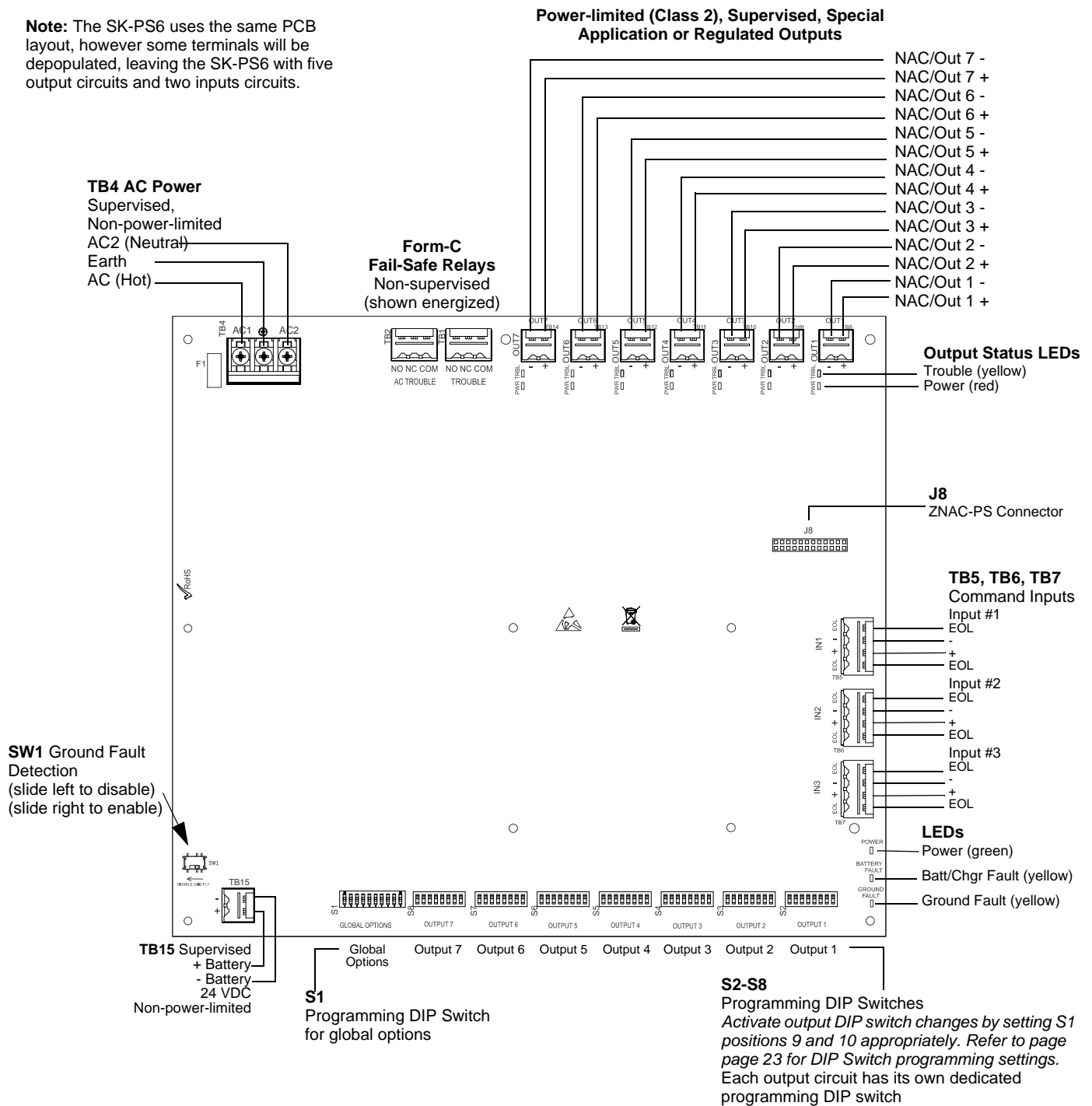

Figure 1.1 SK-PS10 Board Layout

1.6 Applications

The SK-PS may be used in a number of different applications. It may be used as a remotely-mounted power supply and battery charger where it can provide up to seven coded or non-coded, synchronized or non-synchronized NACs (Notification Appliance Circuits). Alternatively, any output can be used as a door holder circuit which will provide a steady 24 VDC output until an alarm condition or AC fail condition causes it to drop to 0 VDC following a selectable delay. See the DIP switch settings for S1 global options on page 21. All outputs can also provide power.

One possible application for the SK-PS remote power supply utilizes the NAC repeater feature. In this application, one or two NACs are connected from the main FACP to the remote power supply command input circuits. When the command input circuits are activated by the reverse polarity of the NACs, the power supply will activate its corresponding output circuits as programmed by its DIP switch configuration (refer to Table 3.7 on page 23).

During the inactive state, the remote power supply supervises its NAC field wiring for short and open conditions. If a fault is detected, the power supply will enter a trouble condition and illuminate the NAC Trouble LED. When the NACs are activated, the supervision is disabled and the circuits are no longer supervised (except for short circuit conditions). Supervision of other power supply faults such as low battery, battery charger trouble, ground fault and AC loss will continue and may be monitored via their respective trouble relay.

If an application requires that all outputs activate at the same time, only one NAC is required from the FACP. For this application, the NAC is connected to command input circuit #1 and the DIP switch is set for this operation.

1.7 Start-up Procedure

1. Configure the power supply switch as described in “Switch SW1 - Ground Fault Detection” on page 9.
2. Install the power supply as described in “Installation” on page 12.
3. Program the power supply as described in “Programming Options” on page 20.
4. Wire the power supply circuits, referring to the options described in “Trouble Supervision” on page 29 and the application examples in “Application Examples” on page 35.
5. Connect primary power source wiring while observing the following:
 - Ensure the AC mains circuit breaker is **off** before making any wiring connections between the mains and the power supply.
 - Make certain primary power source is:
120 VAC, 50/60 Hz, 5.0 (6 amp model) 6.2 amps (10 amp model) Run a pair of wires (with ground conductor) from the protected premises main breaker box to TB4 of the power supply main circuit board.
 - Use #12-14 AWG gauge wire with 600V insulation.
6. Apply power to the power supply using the following procedure:
 - Apply AC power by turning on the AC mains circuit breaker connected to the power supply.
 - Connect a properly charged battery to connector TB15 on the power supply main circuit board.
7. Clear trouble history using global DIP switch S1 positions 9 and 10. See DIP switch settings in Table 3.6 on page 22.

Section 2: Installation

Carefully unpack the system and check for shipping damage. Select a location for the cabinet that is in a clean, dry, vibration-free area where extreme temperatures are not encountered. The area should be readily accessible with sufficient room to easily install and maintain the power supply. With the hinge mounting on the left, determine the number of conductors required for the devices to be installed and determine the appropriate knockouts. All wiring must be in accordance with the National and/or Local codes for fire alarm systems and power supplies.

2.1 Backbox Mounting



CAUTION: STATIC SENSITIVE COMPONENTS

THE CIRCUIT BOARD CONTAINS STATIC-SENSITIVE COMPONENTS. ALWAYS GROUND YOURSELF WITH A PROPER WRIST STRAP BEFORE HANDLING ANY BOARDS SO THAT STATIC CHARGES ARE REMOVED FROM THE BODY. USE STATIC SUPPRESSIVE PACKAGING TO PROTECT ELECTRONIC ASSEMBLIES.

1. Mark and pre-drill holes for the top two keyhole mounting bolts.
2. Install two upper fasteners in the wall with the screw heads protruding approximately 1/4".
3. Using the upper keyholes, mount the backbox over the two screws.
4. Mark the lower two holes, remove the backbox from the wall and drill the mounting holes.
5. Mount the backbox, install the remaining fasteners and tighten all screws..

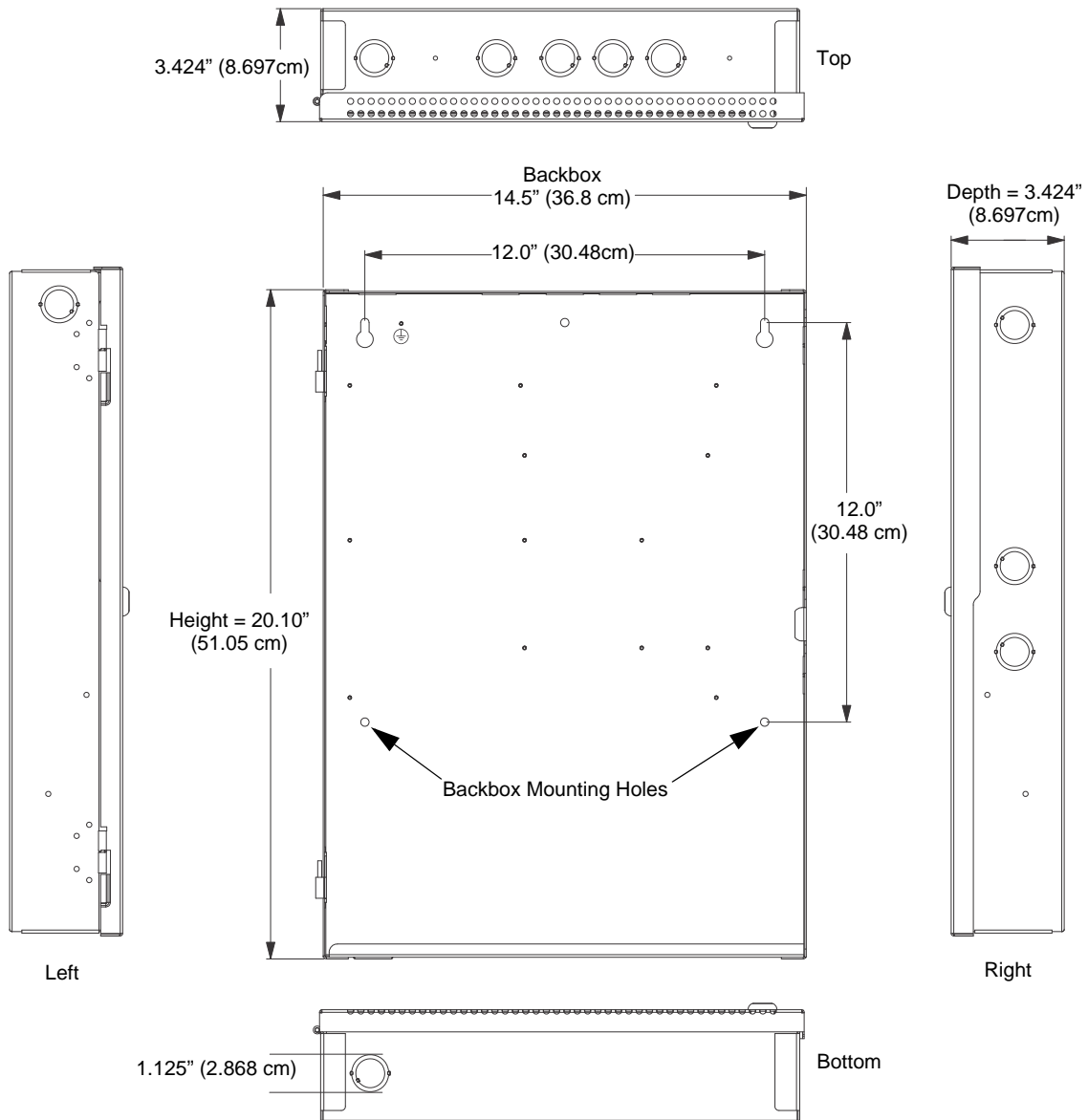

Figure 2.1 Backbox Mounting Dimensions

2.2 NAC Circuit Wiring

2.2.1 Class B

The standard configuration for NACs is Class B as shown below. Use Listed ELRs supplied by the FACP or compatible equipment manufacturer.

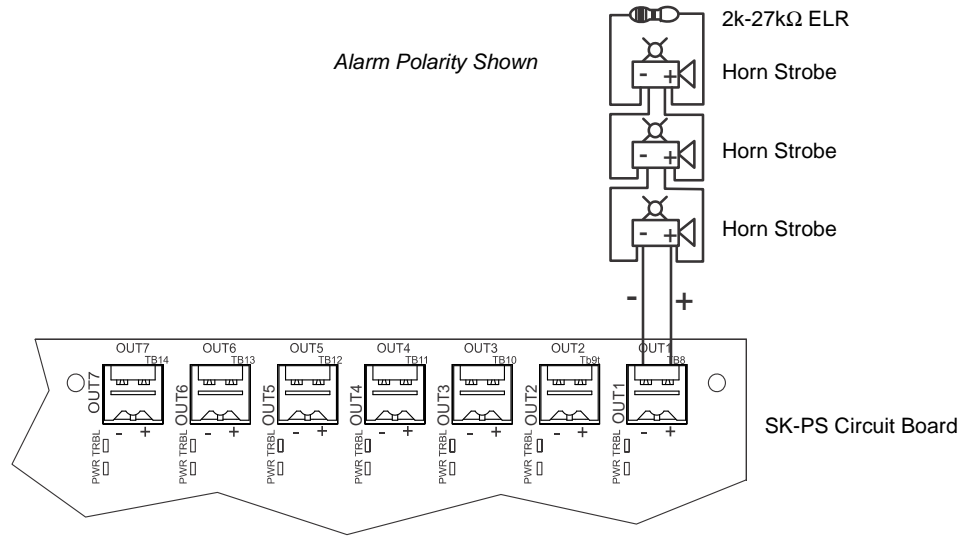

Figure 2.2 NAC Class B

2.2.2 ZNAC-PS Class A Option Module

The ZNAC-PS is an optional Class A conversion module which mounts to connector J8 on the upper right side of the circuit board. This module allows the SK-PS6 or SK-PS10 to support Class A Notification Appliance Circuits on all outputs. Class A power supervision is also supported on output circuits #1 and #2 when either of these outputs are configured as resettable or non-resettable Auxiliary power.

Two slide switches are located on the right side of the ZNAC-PS module to properly configure output circuits #1 and #2 for either NAC or Auxiliary Power operation, as described below. Note that there are no slide switches for the remaining outputs as these outputs do not support Class A power supervision.

- For output #1, set the upper switch to either “NAC1” or “AUX1” depending on the intended operation.
- For output #2, set the lower switch to either “NAC2” or “AUX2” depending on the intended operation.



NOTE: Class A supervision and the ZNAC-PS module are not intended for use with door holder operation.

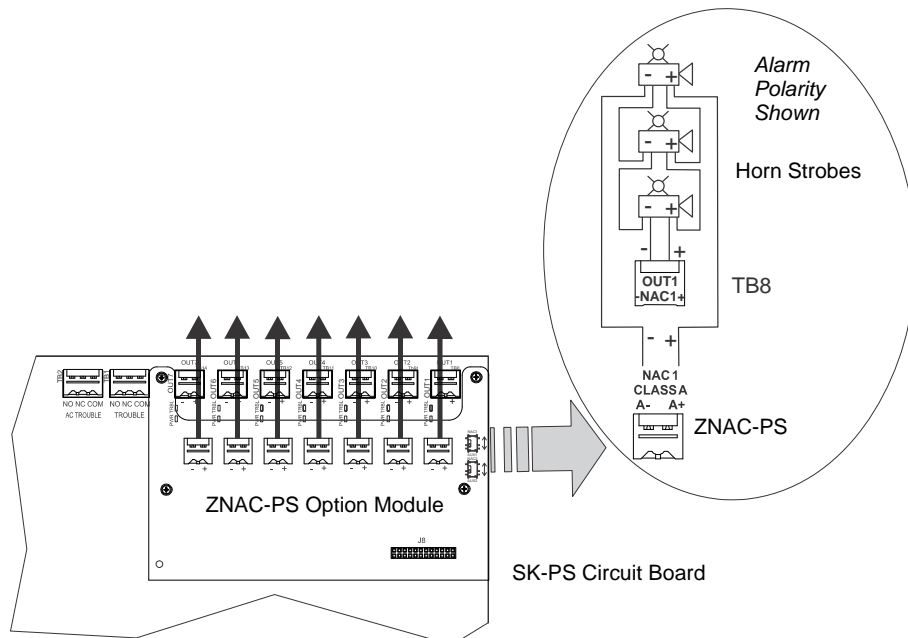

Figure 2.3 Class A NACs using ZNAC-PS Option Module

2.3 Addressable Module Mounting

The SK-PS has been designed to allow the mounting of an addressable control, relay, or monitor module on the main circuit board inside the power supply cabinet. This allows power to be fed from an SK-PS output circuit directly to the module, if needed, without running the power wires outside the cabinet. Remove mounting screws from the positions indicated below and replace with standoffs (included in hardware kit). Mount the module over the standoffs and secure with screws.

Compatible modules include the SK-CONTROL, SK-MONITOR, SK-MONITOR-2, SK-RELAY, SK-RELAYMON-2, SK-CONTROL-6, SK-RELAY-6, and SK-MON-10.



NOTE: PS-MOUNT, the optional hardware kit, ordered separately, contains all necessary hardware for mounting the ZNAC-PS onto the PCB with an additional multi-point module.

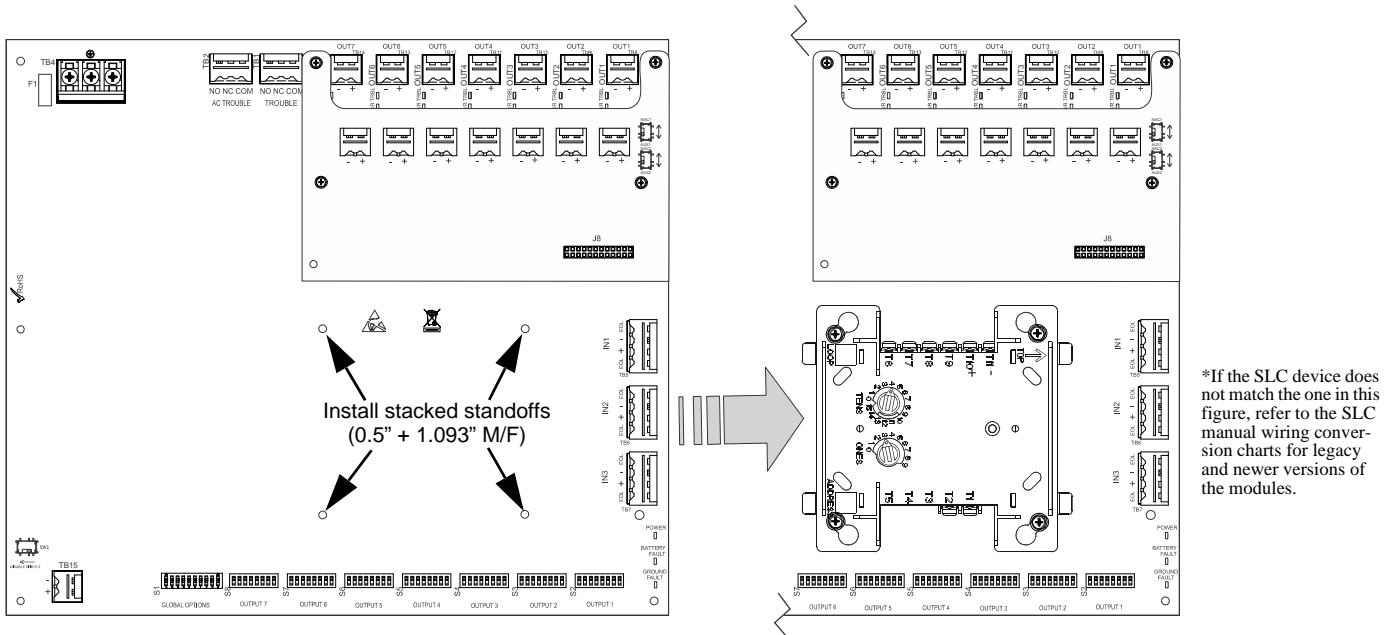
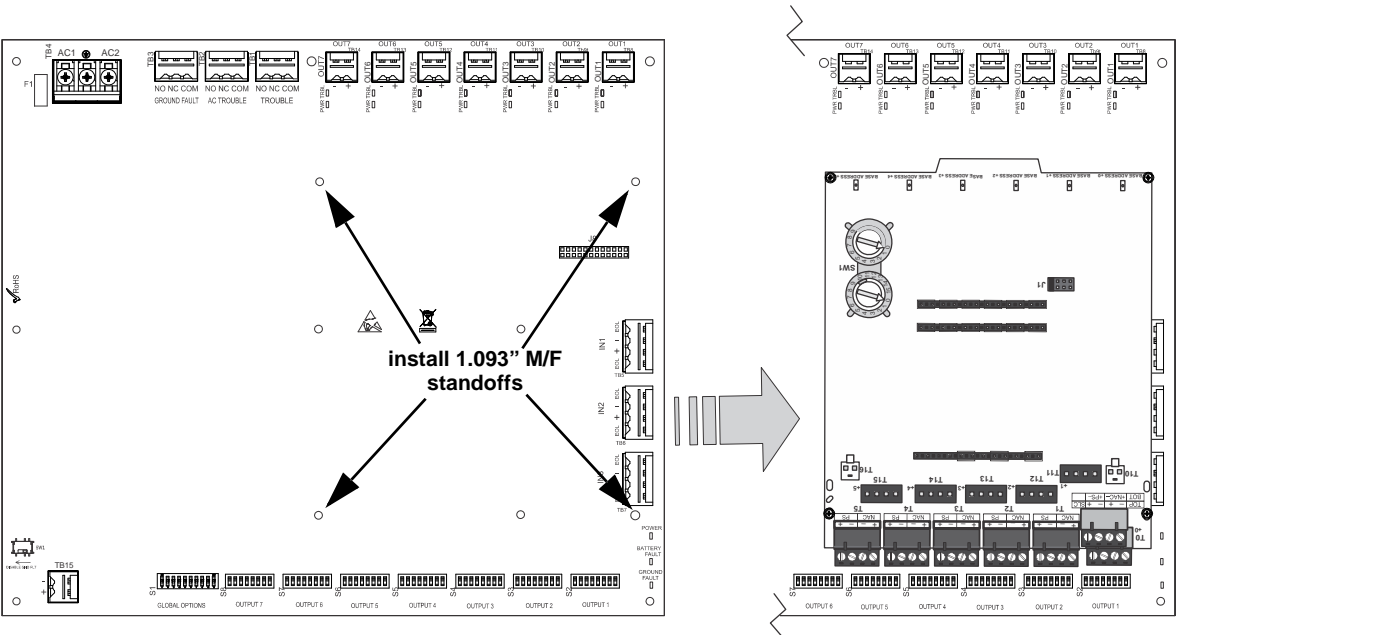

Figure 2.4 Mounting a Single Module in the SK-PS Cabinet



Note: For instructions on mounting a multi-module and a ZNAC-PS module, refer to the ZNAC-PS Install Sheet #LS10228-000GE-E. The multi-module *must* be installed upside down when the ZNAC-PS is installed. If the ZNAC-PS is *not* installed, the multi-module may be mounted in either direction.

Figure 2.5 Mounting a Multi-Module in the SK-PS Cabinet

2.4 NEC Power-limited (Class 2) Wiring Requirements

Power-limited (Class 2) and non-power-limited circuit wiring must remain separated in the cabinet. All power-limited (Class 2) circuit wiring must remain at least 0.25" away from any non-power-limited circuit wiring and all power-limited (Class 2) circuit wiring and non-power-limited circuit wiring must enter and exit the cabinet through different conduits. One such example of this is shown below. Any conduit knockouts may be used. For power-limited (Class 2) applications, use of conduit is optional.

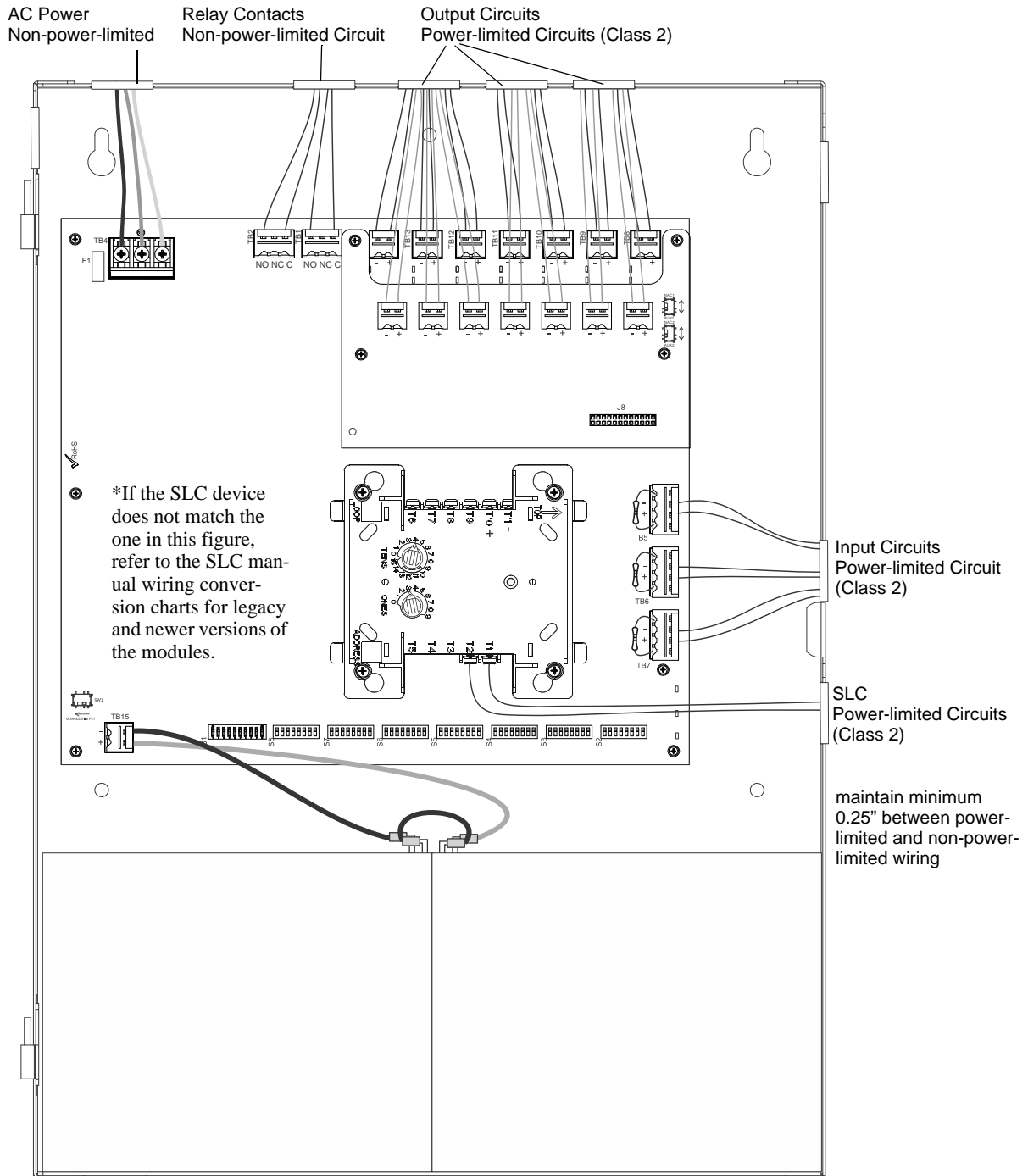

Figure 2.6 Power-limited (Class 2) Wiring Example

2.5 FACP with SK-PS Power Supply in Slave Mode

In this application, an SK-PS power supply, configured as a Slave unit, is connected to a master FACP programmed for synchronized output . .

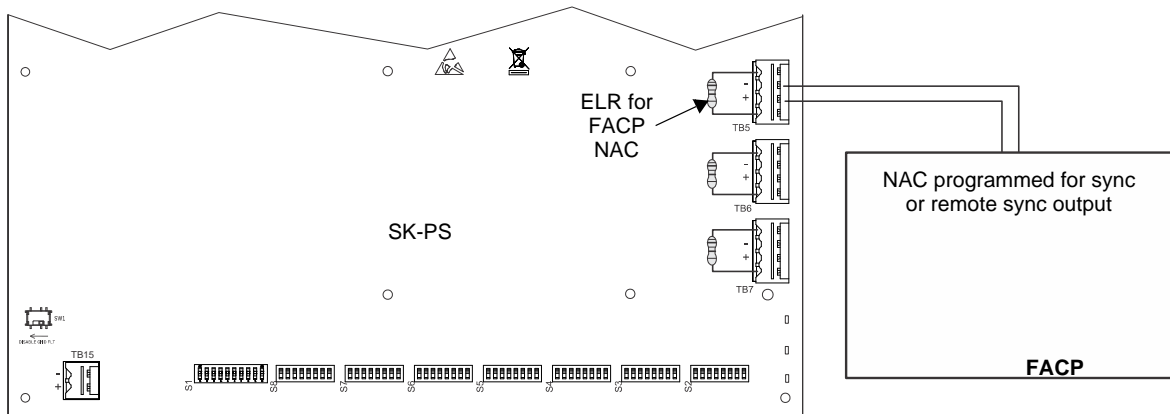

Figure 2.7 Supervised Master/Slave Connections

The following notes apply to Figure 2.7 on page 16

1. Refer to NFPA 72, Chapter 4-4, Visible Characteristics, Public Mode.
2. Use only devices from the same manufacturer in each system.
3. Set Output DIP Switch: position 3=ON, 4 = OFF, 5 = ON, 6 = OFF.
4. If the FACP has a dedicated sync output connector, wire the remote sync output connector to Input #1 terminals 2 and 3.
5. Input#1 is mapped to Slave mode output in this example, but it can be programmed to another input using the DIP switches.
6. Notification appliances cannot be installed on the FACP control circuit connecting to the SK-PS input circuits.

2.6 SK-PS Power Supply in Master Mode Connected to FACP

In this application, a master SK-PS power supply, set for synchronization, is connected to an FACP with non-synchronized output.

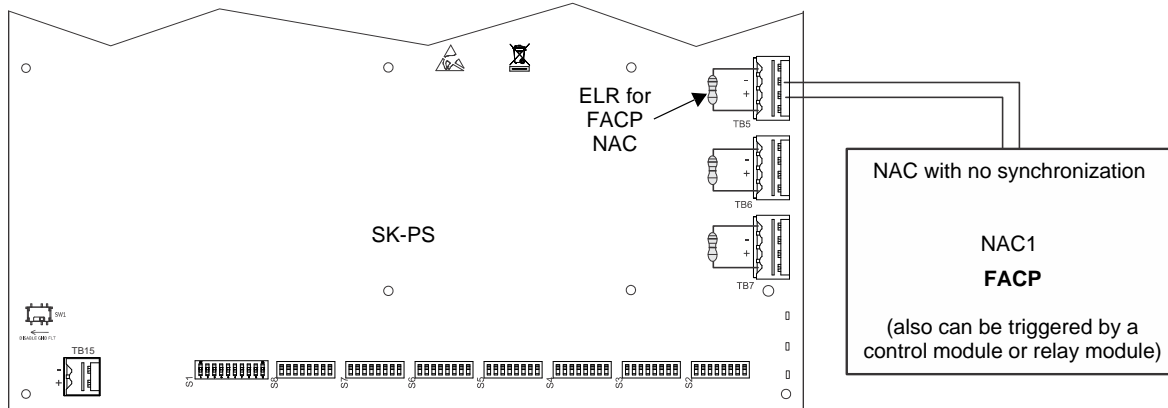

Figure 2.8 Supervised FACP to Master Connections (non-synchronized source)

The following notes apply to Figure 2.8.

1. Refer to NFPA 72, Chapter 4-4, Visible Characteristics, Public Mode.
2. Set Output DIP switches to the desired sync protocol as described below. Refer to the *Device Compatibility Document* for compatible devices.

DIP Switch Position				Synchronization Type
3	4	5	6	
ON	OFF	ON	OFF	Slave mode (NAC follower)
OFF	ON	ON	OFF	Master mode - ANSI Temporal (Temporal 3)
ON	ON	ON	OFF	Master mode - CO Temporal (Temporal 4)
OFF	OFF	OFF	ON	Master mode - Amseco/Potter
OFF	ON	OFF	ON	Master mode - Gentex
OFF	OFF	ON	ON	Master mode - System Sensor
OFF	ON	ON	ON	Master mode - Wheelock
ON	OFF	OFF	ON	Master mode, Selective Silence - Amseco/Potter
ON	ON	OFF	ON	Master mode, Selective Silence - Gentex

ON	OFF	ON	ON	Master mode, Selective Silence - System Sensor
ON	ON	ON	ON	Master mode, Selective Silence - Wheelock

- Use only devices from the same manufacturer in each zone or field of view.
- Input#1 is mapped to Master mode output in this example, but it can be programmed to another input using the DIP switches.
- Notification appliances cannot be installed on the FACP control circuit connecting to the SK-PS input circuits.

2.7 Connecting to an External Charger

The SK-PS Power Supply can be connected to an external charger to charge systems requiring over 33AH batteries. Ensure all power has been disconnected before wiring. Observe polarity when making connections. Wiring must be in conduit within 20 feet (6.096m) in the same room.

2.7.1 CHG-120F

- Set S1 position 4 on the SK-PS Power Supply to the OFF position to disable the onboard battery charger.
- Connect the battery cables between TB15 (+ and -) on the SK-PS and the CHG-120F charger output circuit (TB2: Out 1+ and Out 1-) as shown in Figure 2.9. Be certain to observe polarity.
- Connect the batteries to the charger.
- Connect the battery interconnect cable only after AC power is applied and batteries are connected. Refer to the *CHG-120F Manual* for more information.

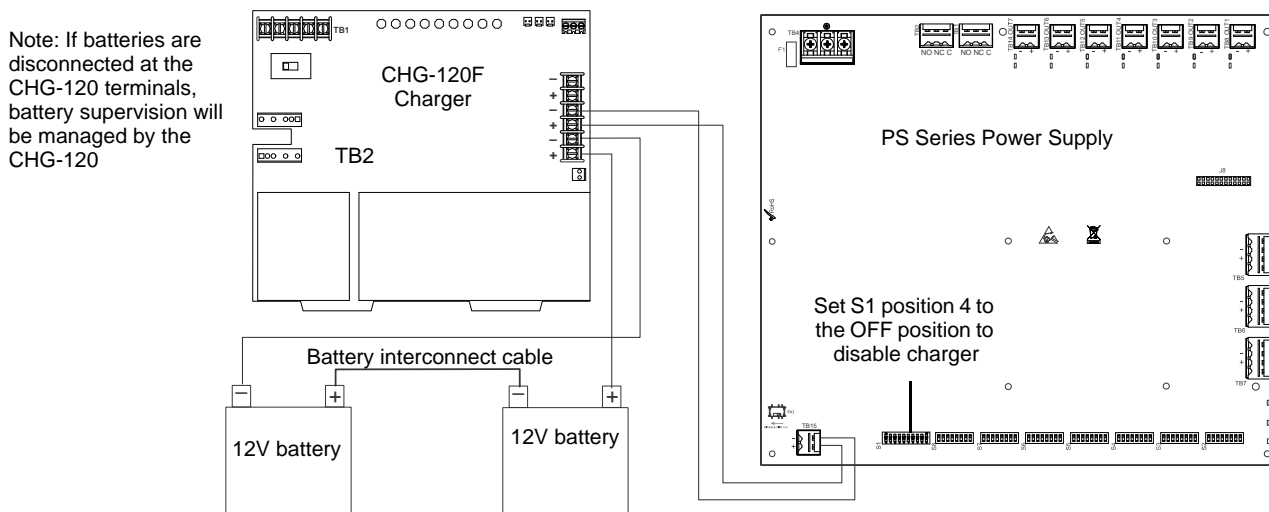

Figure 2.9 Connecting the Power Supply to a CHG-120F Charger

2.7.2 CHG-75

- Set S1 position 4 on the SK-PS Power Supply to the OFF position to disable the onboard battery charger.
- Connect the battery cables between TB15 (+ and -) on the SK-PS and the CHG-75 charger output circuit (TB2: Out+ and Out-) as shown in Figure 2.10. Be certain to observe polarity.
- Connect the batteries to the charger.
- Connect the battery interconnect cable only after AC power is applied and batteries are connected. Refer to the *CHG-75 Manual* for more information.

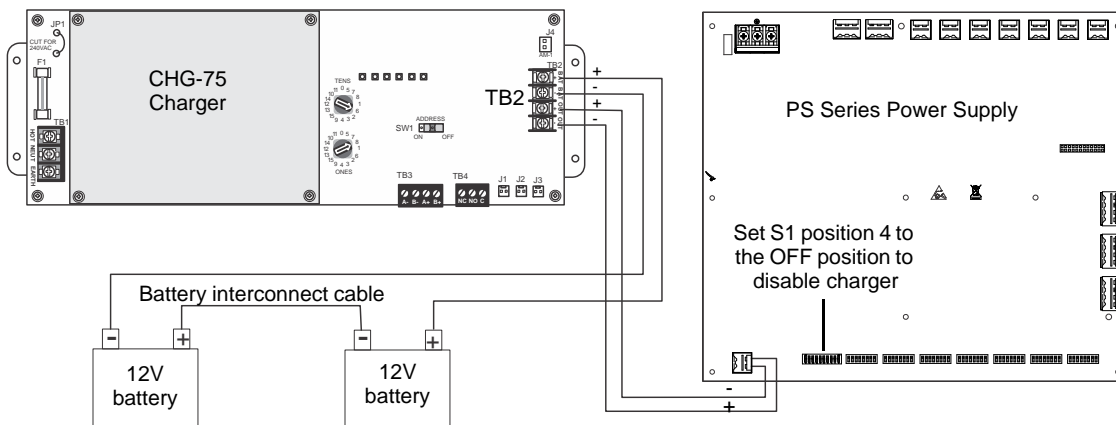

Figure 2.10 Connecting the Power Supply to a CHG-75 Charger

2.8 Cascading Multiple Units

Up to four SK-PS power supplies can be cascaded together to provide additional NAC extenders for a system. Maintain separation of power-limited and non-power-limited wiring as shown in Figure 2.6 on page 15.

Figures 2.11 and 2.12 show the controlling signal connected to Input 1 of SK-PS1. However, typically any available Input of SK-PS1 can be used.

Figures 2.11 and 2.12 show NAC7 of SK-PS1 - SK-PS3 as the cascading output. However, any available Output of SK-PS1 – SK-PS3 can be used.



NOTE: Any mode of operation that requires an additional control signal (i.e. a trigger signal), such as Selective Silence or Sync Mode, will affect which Inputs may be available on PSE1 for use with cascading. (Triggers signals are usually assigned to Input 2.) Refer to those sections of the manual for specifics.

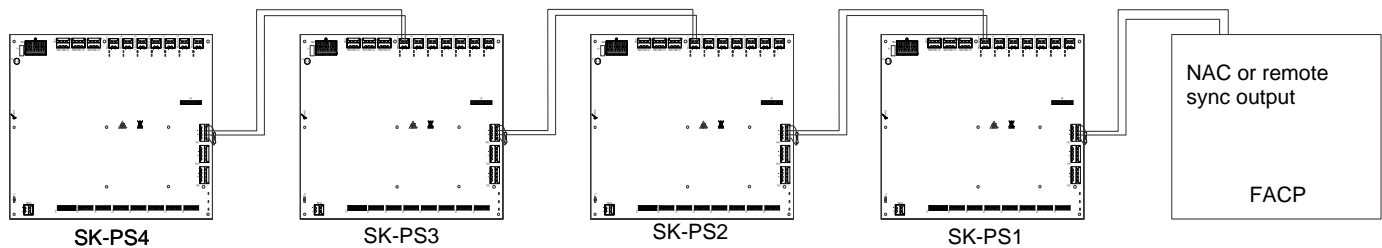

Figure 2.11 System Sync Connections Triggered by FACP

The following notes apply to Figure 2.11.

1. Set all SK-PS units to Slave (sync follower) mode.
2. The debounce/dejitter setting must be set to 1 msec on all cascaded units. See Table 3.3 on page 21.
3. Any output used for remote sync applications cannot have notification appliances installed on the same circuit.
4. Notification appliances cannot be installed on the interconnecting control circuits.
5. The total line impedance for interconnected units cannot be such that it creates a voltage drop > 3.2 VDC.
6. Ground fault supervision is provided via the general trouble relay . Enable ground fault detection on SK-PS1 and disable detection on SK-PS2-4 with negative (-) battery terminals tied together. FACP ground fault supervision will be independent of cascaded PSE1-4. (FACP negative battery terminal is not tied to PSE1).

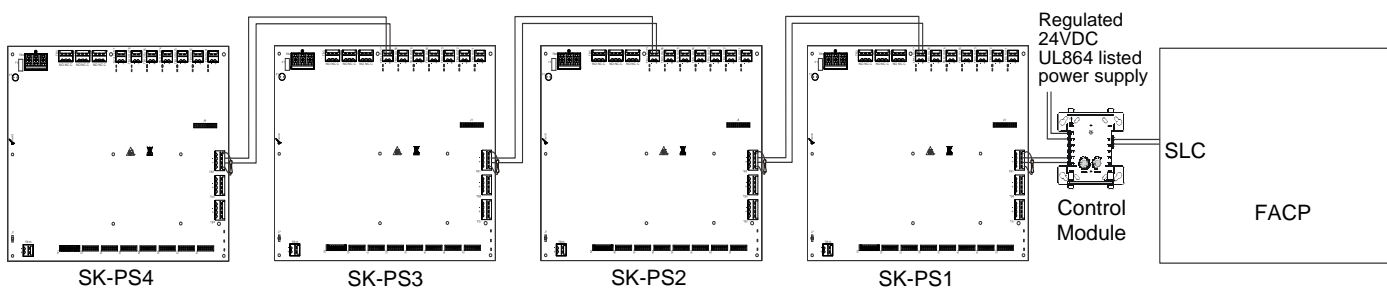

Figure 2.12 System Sync Connections Triggered by Control Module

The following notes apply to Figure 2.12.

1. Set SK-PS1 to Master Mode, and the desired strobe/horn type. Set remaining SK-PS units to Slave (sync follower) mode.
2. The debounce/dejitter setting must be set to 1 msec on SK-PS2 – SK-PS4 units. See Table 3.3 on page 21.
3. Strobe/Horn devices connected to the SK-PS units are not guaranteed to be in sync with FACP devices when using this configuration
4. Any output used for remote sync applications cannot have notification appliances installed on the same circuit.
5. Notification appliances cannot be installed on the interconnecting control circuits.
6. The total line impedance for interconnected units cannot be such that it creates a voltage drop > 3.2 VDC.
7. Ground fault supervision is provided via the general trouble relay . Enable ground fault detection on SK-PS1 and disable detection on SK-PS2-4 with negative (-) battery terminals tied together. FACP ground fault supervision will be independent of cascaded PSE1-4. (FACP negative battery terminal is not tied to PSE1).

✓

Notes

Section 3: Programming Options

NOTICE TO USERS, INSTALLERS, AUTHORITIES HAVING JURISDICTION AND OTHER INVOLVED PARTIES				
This product incorporates field-programmable software. In order for the product to comply with the requirements in the Standard for Control Units and Accessories for Fire Alarm Systems, UL 864, certain programming features or options must be limited to specific values or not used at all as indicated below:				
Program feature or option	Permitted in UL864 and ULC S527? (Y/N)	Possible settings	Settings permitted in UL 864	Settings permitted in ULC S527
Door Holder Dropout Delay	Y	Refer to "AC Loss Door Holder Dropout Timer" on page 22. <ul style="list-style-type: none"> • Does not drop • 15 seconds • 5 minutes • 60 seconds 	<ul style="list-style-type: none"> • Does not drop • 15 seconds • 60 seconds • 5 minutes 	<ul style="list-style-type: none"> • Does not drop • 15 seconds • 60 seconds • 5 minutes
AC Loss Delay Timer	Y	Refer to "AC Fail Indication Delay" on page 22. <ul style="list-style-type: none"> • 30 hours • 12 hours • 2 hours • none 	<ul style="list-style-type: none"> • 2 hours¹ • none 	<ul style="list-style-type: none"> • 2 hours • none

Table 3.1 Agency-Permitted Programming Settings

1 A two hour delay is only permitted on an addressable FACP.

This section describes the programming options available via DIP switch settings. The SK-PS can be field programmed using DIP switches S1-S8 which are located at the bottom of the circuit board. S1 controls the global options of the power supply and S2-S8 control the functions of each output circuit, respectively. Refer to the following illustration for switch locations and DIP switch placement in the ON and OFF positions.

Important: Activate output DIP switch changes by setting S1 positions 9 and 10 appropriately. Refer to Table 3.6 on page 22 for DIP Switch programming settings.

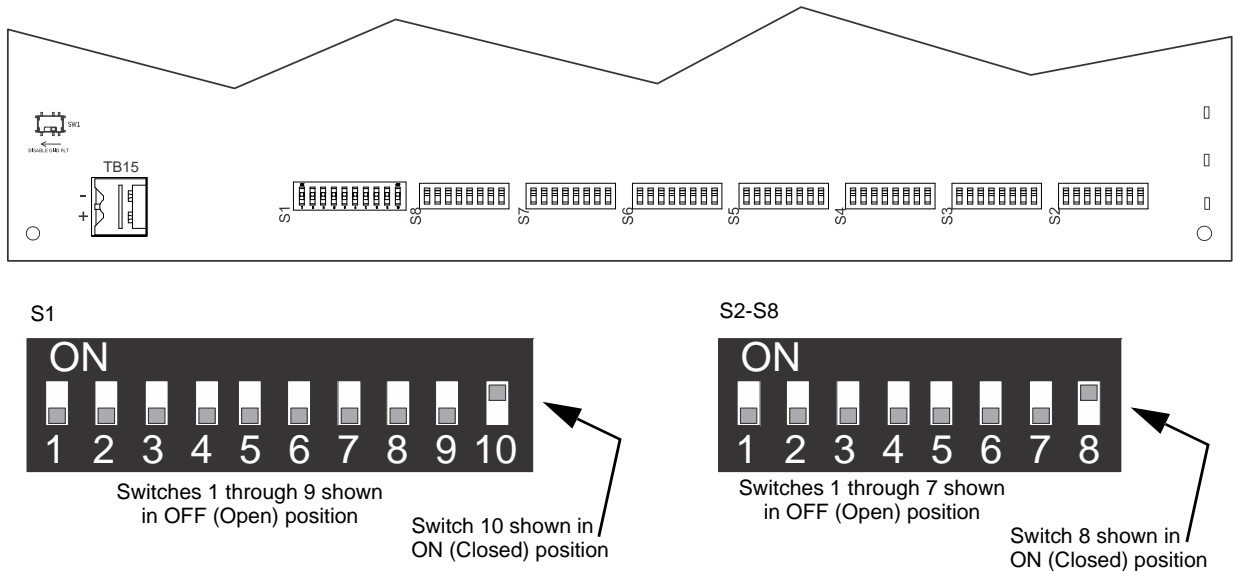

Figure 3.1 Field Programming DIP Switches

3.1 S1 Global Options DIP Switch

The following table lists the global control options for the SK-PS programmable features and the switch settings required to select a particular feature. A detailed description of each feature is presented in the following pages. Refer to Table 3.1 for UL-compliant settings.

S1 DIP Switch	OFF	ON
1, 2	These switches determine the command input debounce/dejitter setting (Setting applies to ALL inputs) ¹ . 1 OFF, 2 OFF = Temporal (for ANSI temporal signals) 1 ON, 2 OFF = 50Hz (20 msec, for full wave rectified signals) 1 OFF, 2 ON = 6 msec (for strobe sync signals, control/relay modules) 1 ON, 2 ON = 1 msec (for strobe sync signals, control/relay modules)	
3	Command Input #1 configured for Slave Mode Sync ² input ³	Command Input #1 configured as normal
4	Internal battery charger = disabled	Internal battery charger = enabled
5, 6	These switches determine door holder dropout delay after AC power loss 5 OFF, 6 OFF = Power does not drop out 5 ON, 6 OFF = 5 minutes 5 OFF, 6 ON = 60 seconds 5 ON, 6 ON = 15 seconds	
7, 8	These switches determine the AC loss delay timer 7 OFF, 8 OFF = 30 hours 7 ON, 8 OFF = 12 hours 7 OFF, 8 ON = 2 hours 7 ON, 8 ON = none	
9, 10	These switches determine the operating mode of the power supply. <i>Return switches to normal mode to exit change output circuit configurations and display trouble history modes!</i> 9 OFF, 10 OFF = normal 9 ON, 10 OFF = change output circuit configurations 9 OFF, 10 ON = display trouble history 9 ON, 10 ON = normal	

Table 3.2 S1 Global Options DIP Switch Settings

- 1 Debounce/dejitter provides settling time for input signals to avoid false triggers.
- 2 Strobe synchronization only works with non-coded NACs.
- 3 Output circuit(s) must be set to activate on Input #2. See, "Command Input #1" below.

3.1.1 Global Programmable Features Description

Input Debounce/Dejitter/Delay

Signals from electronic circuits or relay contacts can have a small unstable time when changing state (OFF to ON, or ON to OFF). This means the signal can briefly "bounce" between states before stabilizing to the desired state, causing signal "jitter" during this time. The SK-PS provides four "debounce/dejitter" settings, as shown in the table below. These settings provide time for a NAC Input signal to stabilize before that NAC Input will recognize it as a valid signal, and not just "noise", so as to prevent false activation of Output circuits. Input debounce settings can be used as needed.

Unless the system experiences input "noise" issues, apply 1ms setting for general use.

Position 1	Position 2	Setting	Notes
OFF	OFF	Temporal	Debounces ANSI temporal signals. Allows for a 0.5 second ON signal with an almost 2 second OFF signal to trigger a continuous ON input signal. <i>Do not use for strobe sync signals.</i>
ON	OFF	50Hz (20msec)	Debounces FWR (full wave rectified signals). Allows an input signal with 50Hz, 33% duty cycle to trigger a continuous (i.e. filters FWR input signal to appear constantly on) ON input signal. May apply to legacy panels. <i>Do not use for strobe sync signals.</i>
OFF	ON	6 msec	Input delay for strobe sync signals (i.e. Slave mode using sync input), or control/relay modules (i.e. Master or Aux. power mode using trigger input).
ON	ON	1 msec	Input delay for strobe sync signals (i.e. Slave mode using sync input), or control/relay modules (i.e. Master or Aux. power mode using trigger input). Must be the only one used when cascading Power Strike units. Refer to Section 2.8, "Cascading Multiple Units", on page 18.

Table 3.3 Debounce/Dejitter Settings

Command Input #1

Power supply Output circuits can be configured to “follow” a sync pattern that is input to Command Input #1 (TB5), either immediately (Normal Mode), or only after a trigger signal (Sync Input Mode) is applied at Command Input #2 (TB6). In Sync Input Mode an output circuit will only output the Command Input #1 sync pattern when Command Input #2 is receiving a valid (9V - 32V) trigger signal.

See “Command Input #1 - Normal/Sync Mode of Operation” on page 25 for additional information.

Charger Enable/Disable

The SK-PS battery charger can be disabled to accommodate an external battery charger, such as the CHG-75 or CHG-120F. Setting DIP switch position 4 to the OFF position will disable the charger. Setting DIP switch position 4 to the ON position will enable the charger. It should only be disabled if an external battery charger is being used for the SK-PS.

AC Loss Door Holder Dropout Timer

Any output can be configured as a NAC, aux power, or door closer circuit. Configuring an output circuit as a door closer circuit will provide a steady 24 VDC to door holders until an alarm condition or an AC fail condition. Upon an alarm condition, power to door holder circuits will be removed, causing doors to close immediately. During an AC fail condition, the door holder will remain energized until the programmed AC fail indication delay expires. Programmed delays are only applicable to AC loss conditions. Refer to Table 3.1 for UL-compliant settings.

DIP switch positions 5 and 6 are used to select the door holder dropout timer as listed below:

Position 5	Position 6	Door holder dropout delay after AC loss
OFF	OFF	Power does not drop out with AC loss
ON	OFF	5 minutes
OFF	ON	60 seconds
ON	ON	15 seconds

Table 3.4 Door Holder Dropout Settings

AC Fail Indication Delay

The AC Fail Indication Delay feature provides the option to delay generation of a trouble signal upon the loss of AC power. Refer to Table 3.1 for UL-compliant settings.

DIP switch positions 7 and 8 are used to select the AC Fail Indication Delay as listed below:

Position 7	Position 8	AC Fail Indication Delay
OFF	OFF	30 hours
ON	OFF	12 hours
OFF	ON	2 hours
ON	ON	none

Table 3.5 AC Loss Delay Settings

Refer to “AC Trouble Relay” on page 29, for operation of internal NAC trouble relay in response to AC loss.

Special Operating Modes

The power supply can be placed in two special operating modes per settings in Table 3.6. They are Change Output Circuit Configurations and Display Trouble History. *Upon completion of either of these two modes, the system must be placed back in normal operating mode. Note that the current operation of all outputs will not be affected or disturbed while in either of these two special operating modes.*

Change Output Circuit Configurations mode:



NOTE: DIP switch settings may be changed to the desired configuration either before or after entering Change Output Circuit Configurations mode.

1. Enter this mode via the setting shown in Table 3.6. Once entered, the Output trouble LEDs will continually flash from right to left to confirm the SK-PS is in Change Output Configuration mode.
2. Configure settings on the Output DIP switches as needed (see Note above).
3. Return to Normal Operating mode via either of the two settings shown in Table 3.6. The output trouble LEDs will stop the flash pattern described above to confirm Normal mode has been restored.

The SK-PS power supply offers a trouble history mode. To see past troubles on the system, place position 9 to OFF and position 10 to ON. Refer to Section 4 for descriptions of troubles. Trouble history will be erased upon returning to Normal operating mode.

DIP switch positions 9 and 10 are used to select the type of operating mode as listed below:

Position 9	Position 10	Operating Mode
OFF	OFF	Normal
ON	OFF	Change output circuit configurations

Table 3.6 Operating Mode

OFF	ON	Display Trouble History
ON	ON	Normal

Table 3.6 Operating Mode

3.2 Output Circuit Control DIP Switch Settings

Each output circuit has its own programming DIP switch. DIP switches S2-S8 are labeled on the PCB to indicate which output circuit it is controlling. Output circuits are labeled at the top of the PCB, TB8-TB14. The following table applies to DIP Switches S2-S8.

Important! If an output circuit is overloaded, the output will shut off and generate a trouble signal. If this happens, the SK-PS will need to be reset manually. Either reset circuit configurations by toggling switch S1 position 10 to the OFF position for a minimum of five seconds or turn off primary and secondary power and reapply to the SK-PS.

DIP Switch Position				Output Control Setting/Operation
	1	2		
	OFF	OFF		NAC output will activate when Command Input #1 is activated.
	ON	OFF		NAC output will activate when Command Input #2 is activated. (Exception: this Input controls Horn silencing during Selective Silence operation.)
	OFF	ON		NAC output will activate when Command Input #3 is activated, if available. (If accidentally programmed on a SK-PS6, the system will default to Input #2.)
	ON	ON		NAC output will activate when ANY Command Input is activated.
3	4	5	6	Output Control Setting/Operation
OFF	OFF	OFF	OFF	Unused/Unsupervised. Outputs will not activate. <i>Factory default setting.</i>
ON	OFF	OFF	OFF	Reserved- Outputs will not activate
OFF	ON	OFF	OFF	Non-resettable auxiliary power
OFF	OFF	ON	OFF	Resettable aux power
ON	ON	OFF	OFF	Door holder auxiliary power
ON	OFF	ON	OFF	Slave mode (NAC follower)
OFF	ON	ON	OFF	Master mode - ANSI Temporal (Temporal 3)
ON	ON	ON	OFF	Master mode - CO Temporal (Temporal 4)
OFF	OFF	OFF	ON	Master mode - Amseco/Potter
OFF	ON	OFF	ON	Master mode - Gentex
OFF	OFF	ON	ON	Master mode - System Sensor
OFF	ON	ON	ON	Master mode - Wheelock
ON	OFF	OFF	ON	Master mode, Selective Silence - Amseco/Potter
ON	ON	OFF	ON	Master mode, Selective Silence - Gentex
ON	OFF	ON	ON	Master mode, Selective Silence - System Sensor
ON	ON	ON	ON	Master mode, Selective Silence - Wheelock
			7	Output Control Setting/Operation (Only applies when ZNAC-PS is installed)
			OFF	Class B
			ON	Class A
			8	Output Control Setting/Operation (Unused)
			OFF	Unused/Unassigned
			ON	Unused/Unassigned

Table 3.7 S2-S8 Output Circuit DIP Switch Settings

3.2.1 Output Circuit Programmable Features Description

Command Inputs/NAC Circuits

The SK-PS allows for individual NAC circuit programming. Each NAC can be configured to activate based on the settings selected for up to 3 command inputs.

Position 1	Position 2	Output to Command Input Assignment
OFF	OFF	NAC will activate when Input #1 activates.
ON	OFF	NAC will activate when input #2 activates. (Exception: this Input controls Horn silencing during Selective Silence operation.)

Table 3.8 NAC Activation Settings

OFF	ON	NAC will activate when input #3 activates. (Input #3 is only available on the SK-PS10 model. If selected on SK-PS6, this setting will default to input #2.)
ON	ON	NAC will activate when any input (1, 2, or 3) activates.

Table 3.8 NAC Activation Settings

Unused Outputs

The factory default setting for all output circuits is “unused/unsupervised” where positions 3, 4, 5, and 6 are set to the OFF position. Any unused or disabled outputs in the system configuration must be set to OFF as shown below.

Position 3	Position 4	Position 5	Position 6	Auxiliary Power Type
OFF	OFF	OFF	OFF	Unused/Unsupervised. Outputs will not activate. <i>Factory default setting.</i>
ON	OFF	OFF	OFF	Reserved- Outputs will not activate

Table 3.9 Auxiliary Power Settings

Remote Supply with Resettable and Non-resettable Power

Each output circuit on the SK-PS can be used as a remote stand-alone power supply to provide power to any devices that require filtered, resettable or non-resettable power. The SK-PS can provide up to 3 amps of continuous current. Non-resettable power is suitable for powering annunciators and other peripheral equipment. Resettable power is suitable for four-wire smoke detectors. Resettable outputs reset when the mapped input receives a negative pulse trigger signal from FACP or control module. There will be a three second delay prior to output reset. The output reset will last 10 seconds. Set DIP switches positions indicated in Table 3.10 below to select auxiliary power type.

Position 3	Position 4	Position 5	Position 6	Auxiliary Power Type
OFF	ON	OFF	OFF	Non-resettable (constant) aux power
OFF	OFF	ON	OFF	Resettable aux power

Table 3.10 Auxiliary Power Settings

Door Holder

Each output circuit can be configured as a door holder circuit. Setting DIP switch positions according to Table 3.11 will configure the selected output circuit as a door holder circuit which will provide a steady 24 VDC to door holders until a mapped input activates an alarm or when an AC fail condition removes the power following a programmable delay. See “AC Loss Door Holder Dropout Timer” on page 22 for more information.

Position 3	Position 4	Position 5	Position 6	Door Holder
ON	ON	OFF	OFF	Set as door holder circuit

Table 3.11 Door Holder Power

Synchronization Mode - Master/Slave

The SK-PS power supply can be configured for Master or Slave Synchronization by setting DIP switches according to Table 3.12. Synchronization is a feature that controls the activation of notification appliances in such a way that all devices will turn on and off at exactly the same time. This is particularly critical when activating strobes which must be synchronized to avoid random activation and a potential hazard or confusion.

In some installations, it is necessary to synchronize the flash timing of all strobes in the system for ADA compliance. Strobes accomplish this by monitoring very short timing pulses on the NAC power which are created by an FACP with synchronization capability. When installed at the end of a NAC wire run, this power supply can track (follow) the strobe synchronization timing pulses on the existing NAC wire run. This maintains the overall system flash timing of the additional strobes attached to this power supply. Note that strobe synchronization works only with non-coded NACs.

When the output circuit is configured as a *sync generator* (Master Synchronization mode), the sync input circuit will only be used to trigger the output. The power supply is the originator of the strobe synchronization pulse on the NAC output. Refer to Table 3.12 to select the desired Master mode sync type.

When the output circuit is configured as a *sync follower* (Slave Synchronization mode), the power supply’s NAC outputs track the strobe synchronization pulses present at the supply’s Input terminals (based on the settings selected from Table 3.8). The pulses originate from an upstream FACP or other power supply. Some FACPs provide synchronization timing pulses from a dedicated sync output connector. Connect the SK-PS input terminals to the FACP sync output connector instead of the FACP NAC.

If circuits are configured for both master and slave mode, devices must be installed in different zones or field of view on a circuit basis.

Position 3	Position 4	Position 5	Position 6	Synchronization Type
ON	OFF	ON	OFF	Slave mode (NAC follower) - NAC outputs track Command Input Circuits
OFF	ON	ON	OFF	Master mode - ANSI Temporal (Temporal 3)

Table 3.12 Sync Mode - Master/Slave Settings

ON	ON	ON	OFF	Master mode - CO Temporal (Temporal 4)
OFF	OFF	OFF	ON	Master mode - Amseco/Potter
OFF	ON	OFF	ON	Master mode - Gentex
OFF	OFF	ON	ON	Master mode - System Sensor
OFF	ON	ON	ON	Master mode - Wheelock

Table 3.12 Sync Mode - Master/Slave Settings

Master Mode - Selective Silence

Selective Silence allows the silencing of the sounder portion of a horn/strobe combination device without turning off the strobe. Selective Silence is only supported while in Master mode setting for Amseco, Gentex, System Sensor, and Wheelock. Refer to Table 3.13 to select the desired Master mode, Selective Silence sync type.



NOTE: Do not apply synchronization signals to Command Input #1 and 2. Only trigger signals are allowed (i.e. constant 9-32 VDC). Synchronization signal is internally generated by the system when in Master mode.

Only Command Inputs #1 and #2 are used to control the Selective Silence operation. (Command Input #3 on SK-PS10 does not support Selective Silence.) Input #1 is for activating the horn/strobe devices, while Input 2 only controls sounding of the horns. Input #1 must be active for Input #2 to have any effect on NAC outputs set for Selective Silence. The list below provides additional detail.

- If only Command Input #1 is active, only the strobes will be activated.
- If both Command Input #1 and #2 are active, strobes and horns will be activated.
- If only Command Input #2 is active, NAC outputs will not be activated.
- If neither Command Input #1 nor #2 is active, NAC outputs will not be activated.

Position 3	Position 4	Position 5	Position 6	Synchronization Type
ON	OFF	OFF	ON	Master mode, Selective Silence - Amseco/Potter
ON	ON	OFF	ON	Master mode, Selective Silence - Gentex
ON	OFF	ON	ON	Master mode, Selective Silence - System Sensor
ON	ON	ON	ON	Master mode, Selective Silence - Wheelock

Table 3.13 Master Mode - Selective Silence Settings

Command Input #1 - Normal/Sync Mode of Operation

For Normal Mode of operation, see previous section.

Sync Mode is an available option for the Slave Synchronization operating mode (see previous section). Sync Mode differs from the Slave Synchronization Normal Mode of operation because it requires an additional “trigger” signal to activate the output(s). Once the trigger signal is active, the corresponding output(s), as selected by the Output DIP Switch settings, will follow any synchronization signal provided to Input #1.

- Input #1 is dedicated as the follower input for any synchronization signal received into this input. Do not apply the trigger signal to this input.
- Input #2 is used for the trigger input for either the 6 amp or 10 amp models. Do not apply the synchronization signal to this input.
- Input #3 can also be used for the trigger input, but is only available on the 10 amp model. Do not apply the synchronization signal to this input.
- Use only one input (Input #2 or #3) at any one time for the trigger input.
- A trigger signal between 9-32VDC is required for proper operation.
- Set the Global DIP switch, S1 position 3, to the OFF position. See below:



NOTE: If Input #1 signal is lost while Input #2 (or Input #3, if available) trigger is active, output circuits will deactivate.

S1 DIP Switch	OFF	ON
3	Command Input #1 configured for Sync input	Command Input #1 configured as normal

Set DIP switch positions 1 and 2 according to which input circuit, #2 or #3, is used as the trigger input as shown below.

Position 1	Position 2	Trigger Input Assignment For Sync Mode Operation
ON	OFF	NAC will activate when Input #2 activates
OFF	ON	NAC will activate when Input #3 activates (Input #3 is only available on the SK-PS10 model. If selected on SK-PS6, this setting will default to input #2.)

DIP switch positions 4, 5, and 6 should be set to Slave Mode as shown below:

Position 3	Position 4	Position 5	Position 6	Synchronization Type for Sync Mode Operation
ON	OFF	ON	OFF	Slave mode (NAC follower) - NAC outputs track Command Input Circuits

Table 3.14 Sync Mode Settings

Class A Wiring

NAC circuits (all outputs) and aux power circuits (outputs 1 and 2) can be converted to Class A wiring using the ZNAC-PS option card. Setting DIP switch position 7=ON when a selected output circuit is configured for Class A wiring. The default setting is OFF for Class B wiring.

■ Maximum Number of Strokes for Synchronization

The total current draw for each Notification Appliance Circuit cannot exceed 3.0 amps special application, 1A (6 amp model) or 1.5A (10 amp model) regulated. Refer to the manufacturer's documentation supplied with the strobe to determine the maximum current draw for each strobe and ensure that the circuit maximum is not exceeded.

To ensure proper strobe and circuit operation, there is also a limit to the number of strobes that can be attached to each circuit. Following is a table of the strobes that have been tested with the power supply and the maximum number that can be connected to each NAC when using the lowest candela settings. *Make sure that the NAC maximum current is not exceeded:*

Manufacturer	max. number of strokes ¹
System Sensor	69
Gentex	42
Wheelock	50
Amseco/Potter	34



Table 3.15 Maximum Number of Strokes

¹ These values are for strobe-only devices at the minimum candela setting. Values will be different for strobe/horn and horn-only devices. Refer to the manufacturer's installation documents for values on these devices.

Section 4: LED Indicators

The SK-PS power supply has 3 system LED indicators for Power, Batt/Chgr Fault, and Ground Fault. In addition, each available output circuit also has 2 status LEDs. Refer to Figure 1.1 on page 10 for LED locations. A description of each SK-PS LED indication is given below.

Ground Fault LED (yellow)

No Fault	LED is OFF 
Fault Condition: ground fault	LED is ON constant 

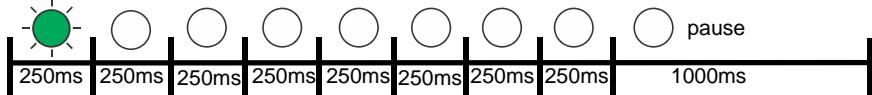

Power LED (green)

No Fault	LED is ON constant 
Fault Condition: AC power loss (or brownout) 1 short blink (250ms)	Repeating LED blink pattern (non-diagnostic mode and diagnostic mode) 

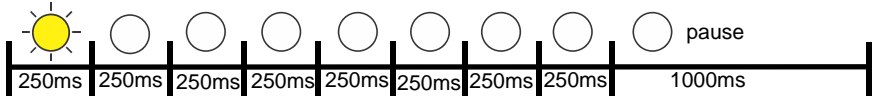
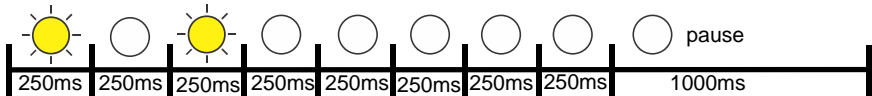
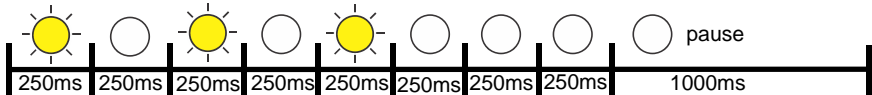
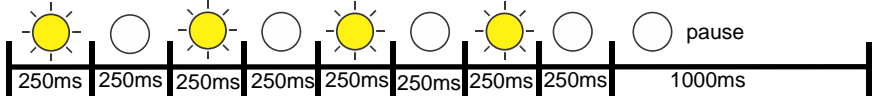
Battery fault LED (yellow)

No Fault	LED is OFF 
Fault Condition: Charging path (FETs) failure 1 short blink (250ms)	Repeating LED blink pattern (non-diagnostic mode and diagnostic mode) 
Fault Condition: Charger voltage too low or Charger Diode Fault 2 short blinks (250ms)	Repeating LED blink pattern (non-diagnostic mode and diagnostic mode) 
Fault Condition: Battery discharged/overcharged 3 short blinks (250ms)	Repeating LED blink pattern (non-diagnostic mode and diagnostic mode) 
Fault Condition: Battery disconnected/fully discharged 4 short blinks (250ms)	Repeating LED blink pattern (non-diagnostic mode and diagnostic mode) 

Output Circuit Status LEDs (red)

Output inactive	LED is OFF 
Output active	LED is ON constant 

Output Circuit Trouble LEDs (yellow)

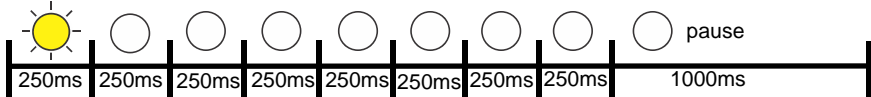
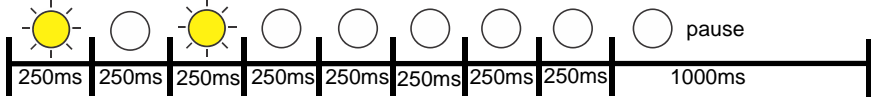
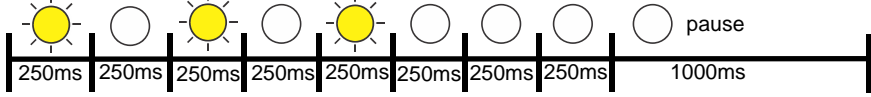
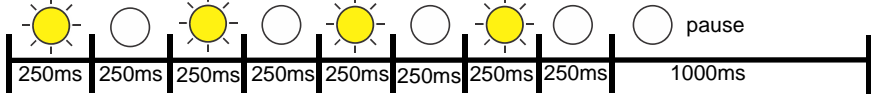
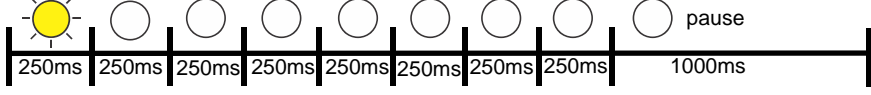
No Fault	LED is OFF 
Fault Condition (Normal/Standby Mode): Wire Supervision Class A or B Open circuit 1 short blink (250ms)	Repeating LED blink pattern (non-diagnostic mode and diagnostic mode) 
Fault Condition (Normal/Standby Mode): Wire Supervision Class A or B Short Circuit 2 short blinks (250ms)	Repeating LED blink pattern (non-diagnostic mode and diagnostic mode) 
Fault Condition: Aux Power Supervision Class A Open circuit (ZNAC-PS Circuit #1 and #2 only) 3 short blinks (250ms)	Repeating LED blink pattern (non-diagnostic mode and diagnostic mode) 
Fault Condition: Power limit condition (individual ckt overload) 4 short blinks per individual circuit (250ms) Fault Condition: Power limit condition (panel overload) 4 short blinks on all output circuits (250ms)	Repeating LED blink pattern (non-diagnostic mode and diagnostic mode) 
Operating Mode Fault: Power Supply not in Normal Operating mode 1 short blink from right to left across all output circuits. Set positions 9 and 10 on S1 to the ON position.	Repeating LED blink pattern (non-diagnostic mode) 

Section 5: Trouble Supervision

The FACP will detect SK-PS power supply faults. Any of the following conditions will cause the trouble contact to open, provided the FACP Notification Appliance Circuit is *not* in alarm.

5.1 Trouble Supervision Using Input Circuits

The FACP (Fire Alarm Control Panel) supervises the connection between itself and the SK-PS via the control panel's NAC End-of-Line Resistor (ELR). To supervise the SK-PS, an ELR must be installed across terminals 1 & 4 of Command Inputs #1 and #2 (and #3 for the 10 amp models). A field wiring fault on the NAC output of the SK-PS will trigger a disconnection of the ELR at the related Command Input, causing a general NAC trouble at the FACP provided the FACP's NAC is *not* in alarm. Refer to Section 3.2, "Output Circuit Control DIP Switch Settings", on page 23 for input/output configuration assignment. The following are exceptions.

1. Resettable Aux Power, Non-Resettable Aux Power, and Door Holder Aux Power outputs that trigger the Trouble relay during an output trouble instead of breaking the ELR connection at the Command Input regardless of the output to input relationship (i.e. mapping). Refer to 5.2, "Trouble Relay" below.
2. Faults are only reported by Command Input #1 when Selective Silence output mode is controlled by Command Input #1 and #2.
3. Faults are only reported by the trigger input when Command Input #1 is configured for Sync Input mode operation controlled by a sync and trigger input.

If the SK-PS is in alarm, only a short circuit on the NAC will be detected as a trouble.

If other trouble monitoring is required when the power supply is in alarm, the Trouble Relay at TB1 and AC Trouble at TB2 can be used for this purpose.

5.2 Trouble Relay

The SK-PS power supply has a fail-safe Form-C trouble relay located at TB1. The contacts can be monitored by an FACP input circuit or an addressable monitor module as illustrated in Figure 5.1. Note that any faults reported by Command Inputs are not repeated by the trouble relay, offering limited trouble reporting.

Trouble conditions that will cause the normally energized trouble relay to change states regardless of whether the panel is in alarm or standby:

- A battery fail condition at the power supply
- A battery charger fail on the power supply
- A ground fault condition on the power supply
- A field wiring fault on the SK-PS output in Resettable Aux Power, Non-Resettable Aux Power, or Door Holder Aux Power mode
- A total panel overload fault

If trouble monitoring is required when the power supply is in alarm, the Trouble Relay at TB1 can be used for this purpose. Refer to Figure 5.1 below.



NOTE: The individual NAC Trouble LED will indicate which NAC circuit is in trouble.

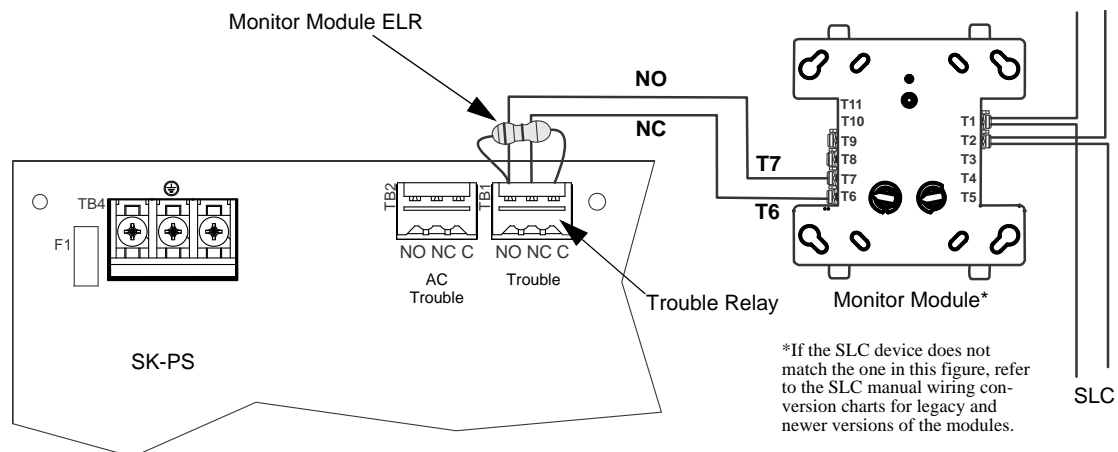

Figure 5.1 Monitoring the Trouble Relay

5.3 AC Trouble Relay

The SK-PS power supply has a fail-safe Form-C trouble relay located at TB2. The contacts can be monitored by an FACP input circuit or an addressable monitor module similar to the drawing illustrated in Figure 5.1. The AC Trouble Relay responds to an AC fail condition on the SK-PS immediately, or after a programmed delay time, depending on the setting of S1 switches 7 and 8.

The reporting of AC loss to a central station is usually delayed in order to prevent multiple transmissions of AC loss and restoration, allowing AC power to stabilize. When a host FACP is programmed to delay AC loss reporting, the SK-PS must be configured to delay the reporting of AC fail. This is accomplished by setting S1 positions 7 and 8. Refer to the DIP switch setting chart in Table 3.5 on page 22. This will prevent AC loss from being reported as a trouble condition for 30, 12, 2, or 0 hours. Note that only no delay and the 2 hour delay are acceptable per UL 864 and UL 2572.

Notes

Section 6: Power Supply Requirements

6.1 Overview

This section contains instructions and tables for calculating power supply currents in alarm and standby conditions. This is a four-step process, consisting of the following:

1. Calculating the total amount of AC branch circuit current required to operate the system
2. Calculating the power supply load current for secondary non-fire and fire alarm conditions
3. Calculating the size of batteries required to support the system if an AC power loss occurs
4. Selecting the proper batteries for your system

6.2 Calculating the AC Branch Circuit

The power supply requires connection to a separate, dedicated AC branch circuit, which must be labeled **FIRE ALARM**. This branch circuit must connect to the line side of the main power feed of the protected premises. No other non-fire alarm equipment may be powered from the fire alarm branch circuit. The branch circuit wire must run continuously, without any disconnect devices, from the power source to the power supply. Overcurrent protection for this circuit must comply with Article 760 of the National Electrical Codes as well as local codes. Use a minimum of 14 AWG (2.00 mm²) wire with 600 volt insulation for this branch circuit.

Use Table 6.1 to determine the total amount of current, in AC amperes, that must be supplied to the system.

Device Type	Number of Devices		Current Draw (AC amps)		Total Current per Device
SK-PS6 or SK-PS10	1	x	5.0 or 6.2	=	
[]	[]	x	[]	=	
[]	[]	x	[]	=	
Sum Column for AC Branch Current Required				=	

Table 6.1 120 VAC Branch Circuit Requirements

6.3 Calculating the System Current Draw

6.3.1 Overview

The power supply must be able to power all internal and external devices continuously during a fire alarm condition. The secondary power source (batteries) must be able to power the system during a primary power loss. To calculate the non-fire alarm load on the power supply when secondary power is applied, use Calculation Column 1 in Table 6.3 on page 32. The power supply must support a larger load current during a fire alarm condition. To calculate the fire alarm load on the power supply as secondary power, use Calculation Column 2 in Table 6.3 on page 32.

When calculating current draw and the battery size, note the following:

- *Primary* refers to the main power source for the power supply.
- *Secondary* refers to the power supply's backup batteries.
- All currents are given in amperes (A). Table 6.2 shows how to convert milliamperes and microamperes to full amperes.

To convert...	Multiply	Example
Milliamperes (mA) to amperes (A)	mA x 0.001	3 mA x 0.001 = 0.003 A
Microamperes (μA) to amperes (A)	μA x 0.000001	300 μA x 0.000001 = 0.0003 A

Table 6.2 Converting to Full Amperes

6.3.2 How to Calculate System Current Draw

Use Table 6.3 to calculate current draws as follows and refer to the battery calculation tool on www.silentknight.com or www.faren-hyt.com.

1. Enter the quantity of devices in both columns.
2. Enter the current draw where required. Refer to the *Silent Knight Device Compatibility Document* for compatible devices and their current draws.
3. Calculate the current draws for each in both columns.
4. Sum the total current for each column.

Following are the types of current that can be entered into Table 6.3.

- ✓ **Calculation Column 1** - The secondary supply current load that the power supply must support during a non-fire alarm condition, with DC power applied
- ✓ **Calculation Column 2** - The secondary supply current load the power supply must support during a fire alarm condition, with DC power applied

Table 6.3 contains two columns for calculating current draws. For each column, calculate the current and enter the total (in amperes) in the bottom row. When finished, use the data to select the proper size batteries in Tables 6.4 and 6.5.

Device Type	Calculation Column 1 Secondary, Non-Fire Alarm Current (amps)			Calculation Column 2 Secondary, Fire Alarm Current (amps)		
	Qty	X (current draw) =	Total	Qty	X (current draw) =	Total
Main Circuit Board - SK-PS6 with all outputs 2k EOL	1	X [0.154] =		1	X [0.192] =	
Main Circuit Board - SK-PS6 with 4.7k EOL	1	X [0.139] =		1	X [0.157] =	
Main Circuit Board - SK-PS6 with 27k EOL	1	X [0.124] =		1	X [0.137] =	
Main Circuit Board - SK-PS6 with all Outputs Aux Power Class B	1	X [0.132] =		1	X [0.132] =	
Main Circuit Board - SK-PS6 with ZNAC-PS Class A option card with all outputs Aux Power	1	X [0.142] =		1	X [0.142] =	
Main Circuit Board - SK-PS10 with all outputs 2k EOL	1	X [0.178] =		1	X [0.232] =	
Main Circuit Board - SK-PS6 with 4.7k EOL	1	X [0.156] =		1	X [0.185] =	
Main Circuit Board - SK-PS6 with 27k EOL	1	X [0.135] =		1	X [0.154] =	
Main Circuit Board - SK-PS10 with all Outputs Aux Power Class B	1	X [0.149] =		1	X [0.149] =	
Main Circuit Board - SK-PS10 with ZNAC-PS Class A option card with all outputs Aux Power	1	X [0.160] =		1	X [0.160] =	
NAC/Output #1	[]	X [] =		[]	X [] =	
NAC/Output #2	[]	X [] =		[]	X [] =	
NAC/Output #3	[]	X [] =		[]	X [] =	
NAC/Output #4	[]	X [] =		[]	X [] =	
NAC/Output #5	[]	X [] =		[]	X [] =	
NAC/Output #6	[]	X [] =		[]	X [] =	
NAC/Output #7	[]	X [] =		[]	X [] =	
EOLR-1 Power Supervision Relay	[]	X [0.020] =		[]	X [0.020] =	
Sum each column for totals		Secondary Non-Alarm =			Secondary Alarm =	

Table 6.3 System Current Draw Calculations

6.4 Selecting and Locating Batteries

Select batteries that meet or exceed the total ampere hours determined in Tables 6.4 and 6.5. The power supply can charge batteries from 7 AH to 33 AH range. The power supply cabinet is capable of housing industry standard 7 AH or 18 AH batteries. Other ampere batteries (e.g. 12AH, 26AH, 33AH) will not fit physically inside the SK-PS cabinet and require a separate battery box.

6.4.1 NFPA Battery Requirements

NFPA 72 Local and Proprietary Fire Alarm Systems require 24 hours of standby power followed by 5 minutes in alarm for normal operations or 15 minutes for mass notification systems.



NOTE: When using carbon monoxide detection, the system must be monitored by a Supervising Station meeting the Standard for the Installation of Carbon Monoxide (CO) Detection and Warning Equipment, NFPA 720.

6.4.2 Maximum Battery Standby Load

Tables 6.4 and 6.5 show the standby load calculations for the power supply based on 24 hours of standby. The standby load calculations in the Table 6.3 must be less than the number shown in Tables 6.4 and 6.5 for the selected battery size, standby hour and alarm time. The numbers below have a built in 20% derating factor for the battery ampere capacity.

Battery Capacity (AH)	Alarm Time (min)				
	5	10	15	20	30
7	0.212 A	0.190 A	0.169 A	0.147 A	N/A
12	0.379 A	0.357 A	0.336 A	0.314 A	0.271 A
18	0.579 A	0.557 A	0.536 A	0.514 A	0.471 A
33	1.079 A	1.057 A	1.036 A	1.014 A	0.971 A
75	2.479 A	2.457 A	2.436 A	2.414 A	2.371 A
120	3.000 A	3.000 A	3.000 A	3.000 A	3.000 A

Table 6.4 Maximum Battery Standby Loads for 24 Hour Standby on the SK-PS6

Battery Capacity (AH)	Alarm Time (min)				
	5	10	15	20	30
7	0.198 A	0.162 A	N/A	N/A	N/A
12	0.364 A	0.329 A	0.293 A	0.258 A	0.187 A
18	0.564 A	0.529 A	0.493 A	0.458 A	0.387 A
33	1.064 A	1.029 A	0.993 A	0.958 A	0.887 A
75	2.464 A	2.429 A	2.393 A	2.358 A	2.287 A
120	3.000 A	3.000 A	3.000 A	3.000 A	3.000 A

Table 6.5 Maximum Battery Standby Loads for 24 Hour Standby on the SK-PS10

Section 7: Testing and Maintenance

7.1 Periodic Testing and Service

Periodic testing and servicing of equipment is essential to ensure proper and reliable operation. Test and service the power supply according to the schedules and procedures outlined in the following documents:

- NFPA Standard 72's section on Inspection, Testing and Maintenance

7.2 Battery Checks and Maintenance

Maintenance-free sealed lead-acid batteries used in the system do not require the addition of water or electrolyte. These batteries are charged and maintained in a fully charged state by the main power supply's charger during normal system operation. A discharged battery typically reaches the voltage of 27.6 VDC within 48 hours;. Sealed lead-acid batteries must be replaced within at most 5 years from their date of manufacture. Minimal replacement battery capacity appears on the control panel marking label. Immediately replace a leaking or damaged battery. Replacement batteries are available from the manufacturer.



WARNING: SULFURIC ACID

BATTERIES CONTAIN SULFURIC ACID WHICH CAN CAUSE SEVERE BURNS TO THE SKIN AND EYES AND DAMAGE TO FABRICS.

F1 Fuse Replacement	Not Allowed
Rechargeable Battery Replacement	Recommended Part Numbers: <ul style="list-style-type: none"> • BAT-1270 (12V,7AH) • BAT-12120 (12V, 12AH) • BAT-12180 (12V 18AH) • BAT-12260 (12V, 26AH) • BAT-12330 (12V, 33AH)

Appendix A: Wire Requirements

Connecting external system accessories to the main circuits must be carefully considered to ensure proper operation. It is important to use the correct type of wire, gauge and run length for each circuit. The following table lists NAC wiring requirements for the SK-PS6 and SK-PS10 Power Supply.

The numbers documented in this chart are worst case numbers, based on the conditions listed below. The maximum voltage drop, maximum loop resistance, and wire length ratings can be increased with lower system current loading.

1. The SK-PS6/10 is full capacity loaded at 6A/10A.
2. The SK-PS6/10 is running at the Low Battery voltage of 20.4VDC (at Battery Connector TB15).

Wire lengths apply to Class B wiring, and to Class A wiring returned to the ZNAC-PS card.

Max Load (Amps)	Max Loop Resistance (Ohms)	AWG 12 (Solid)	AWG 14 (Solid)	AWG 16 (Solid)	AWG 18 (Solid)
0.25	12.804	3320	2087	1310	823
0.50	6.402	1660	1044	655	412
0.75	4.268	1107	696	437	274
1.00	3.201	830	522	327	206
1.25	2.561	664	417	262	165
1.50	2.134	553	348	218	137
1.75	1.829	474	298	187	118
2.00	1.601	415	261	164	103
2.25	1.423	369	232	146	91
2.50	1.280	332	209	131	82
2.75	1.164	302	190	119	75
3.00	1.067	277	174	109	69

Table A.1 Wiring Requirements for Power Supply



NOTE: Calculations are based on Direct-Current Resistance data for uncoated copper wire, per National Electrical Code (2005 Edition) Table 8, Conductor Properties.



NOTE: These distances reflect the worst case scenario and are based on the correct draw of the highest candela strobes at the low end of the supported NAC voltage with the entire load at the end of the circuit. Further distances can be achieved by performing a point to point voltage calculation that more accurately reflects the specific devices used and how they are dispersed on the circuit.

Appendix B: Application Examples

B.1 Controlling NACs For Selective Silence Operation Using a Control Module

In this application, the power supply has been set as a master with synchronized outputs and selective silence (see DIP switch settings and Selective Silence Operation information in Section 3). This application requires Input #1 to be controlled by the FACP. Input #2 is required for controlling selective silence via a control/relay module, *programmed as an alarm output and a silenceable point*. Only Mass Notification, Fire, or combo Mass Notification/Fire NACs are allowed in this configuration. The control module can be powered by one of the SK-PS output circuits, configured as aux power (24VDC).

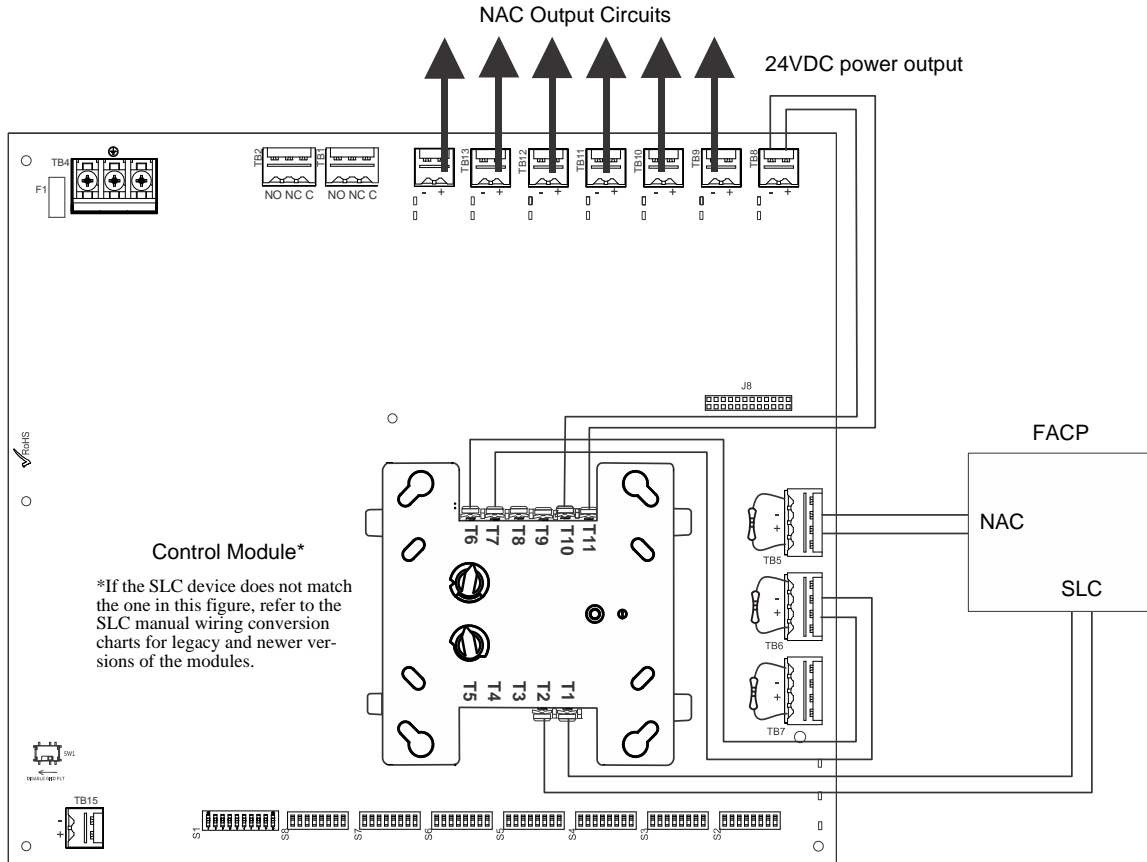

Figure B.1 Controlling Multiple Outputs with One Input

The following notes apply to Figure B.1.

When the SK-PS power supply is in an inactive state (FACP NAC not active), a trouble on the NAC circuit will result in an open circuit condition on the FACP (monitored by End-of-Line Resistor across TB5, Terminals 1 and 4). As an alternative, the trouble contacts at TB1 of the power supply can also be used for limited trouble monitoring excluding Selective Silence output faults. Refer to Section 5 for more information.

- Refer to Section 3 for instructions on setting the DIP switches.
- Selective Silence output faults are only reported via Command Input #1 (not Command Input #2).
- Wire NACs as shown on page 13.
- Do not loop wires under screw terminals. Break wires to maintain proper supervision.
- An End-of-Line Resistor must be installed across all input circuits, Terminals 1 and 4, for control module wiring supervision (the ELR value is dependent on the module/FACP employed).
- For a list of compatible devices, refer to the *Silent Knight Device Compatibility Document #52612*.
- Refer to the *SLC Wiring Manual* for more information.

B.2 Controlling NACs For Sync Follower Operation Using a Control Module

In this application, the power supply has been set to operate in slave mode and will follow the sync signal from the FACP. This application requires Input #1 to be controlled by the FACP sync output. Input #1 may be wired to the next SK-PS or terminate in an ELR. Input #2 (or Input #3, if available) will act as the trigger signal for the output circuits. The control module can be powered by one of the SK-PS output circuits, configured as aux power (24VDC). See Table 3.14 on page 25 DIP switch settings.

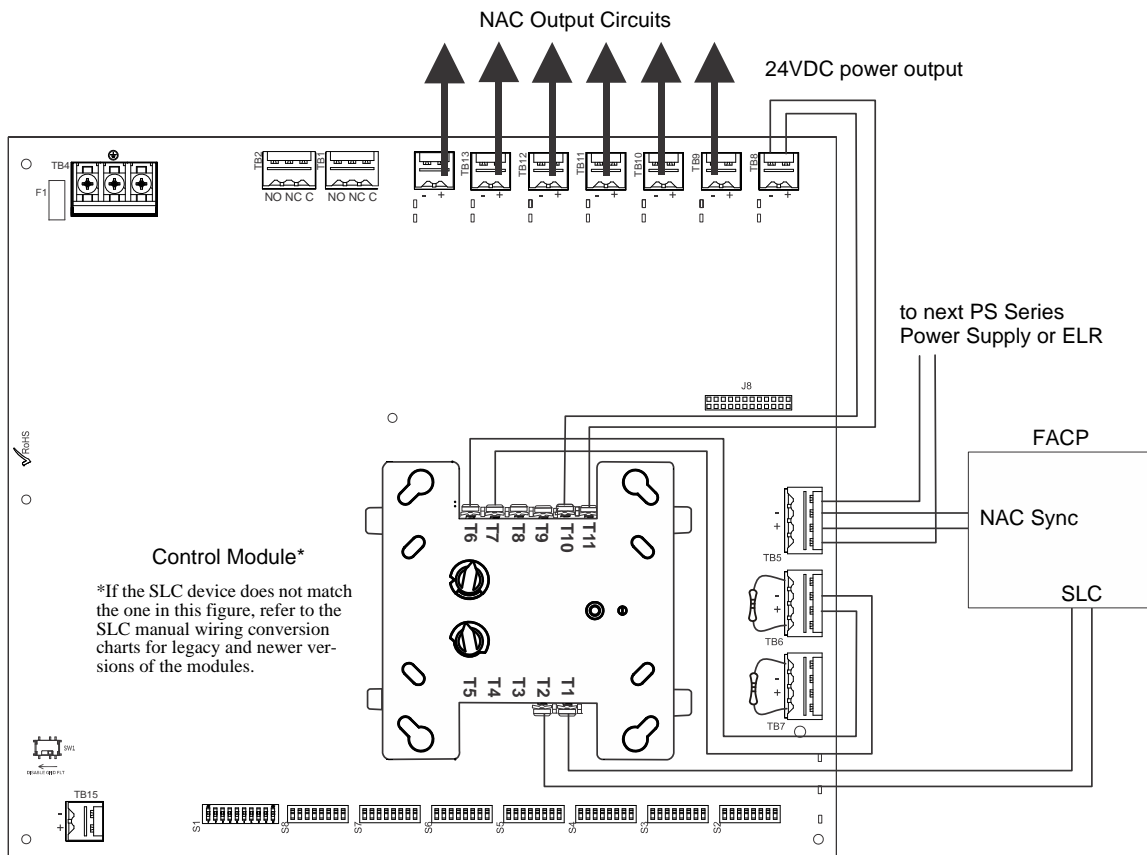

Figure B.2 Controlling Multiple Outputs with One Input as Sync Follower

The following notes apply to Figure B.2.

- When the SK-PS power supply is in an inactive state (control module not active), a trouble on the NAC circuits mapped to TB6 will result in an open circuit condition on the control module output circuit (monitored by End-of-Line Resistor across TB6, Terminals 1 and 4). As an alternative, the trouble contacts at TB1 of the power supply can also be used for limited trouble monitoring excluding faults reported by Command Input #2 related to Command Input#1 configured for Sync Input mode. Refer to Section 5 for more information.
- Refer to Section 3 for instructions on setting the DIP switches.
- Output faults are reported via Command Input#2 with Command Input#1 configured for Sync Input mode operation.
- Refer to the FACP manual for load restrictions and line length limitations when wiring multiple power supplies at the input.
- Wire NACs as shown on page 13.
- Do not loop wires under screw terminals. Break wires to maintain proper supervision.
- An End-of-Line Resistor must be installed across all input circuits, Terminals 1 and 4, for control module wiring supervision (the ELR value is dependent on the module/FACP employed).
- For a list of compatible devices, refer to the *Silent Knight Device Compatibility Document #52612*.
- Refer to the *SLC Wiring Manual* for more information.

B.3 Controlling NACs, Aux Power, or Door Holders Using a Control Module

All output circuits, NACs, aux power (non-resettable power – active regardless of control module state), or door holders, can be controlled from one input such as an addressable control module as illustrated in Figure B.3. The control module can be powered from one of the SK-PS output circuits, as 24 VDC power. In this example, Output #1 will be configured as 24VDC non-resettable aux power. The control module is shown to demonstrate the use of an internally mounted device associated with an addressable fire alarm control panel. The module could be replaced with any circuit capable of polarity reversal, such as an FACP Notification Appliance Circuit.

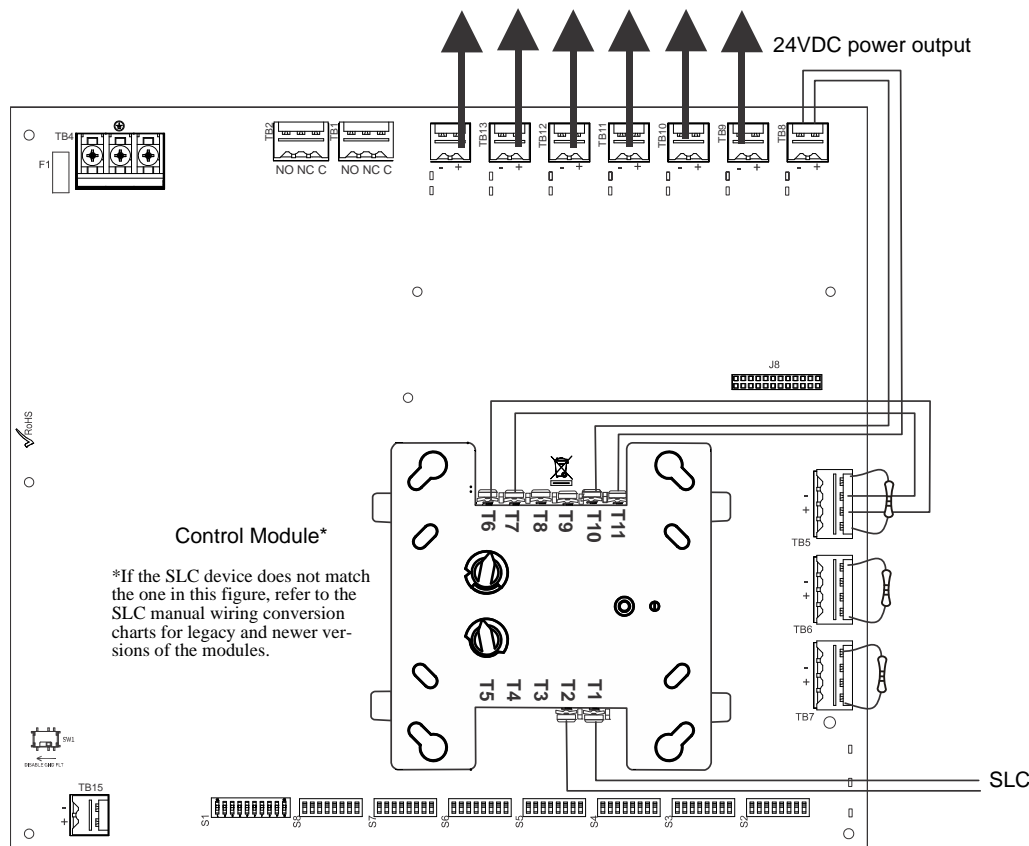

Figure B.3 Controlling NACs, Aux Power, and Door Holders with One Input

The following notes apply to Figure B.3.

- Any output circuit can be configured as NAC, door holder, or 24VDC power.
- Wire NACs as shown on page 13.
- Refer to Section 3 for instructions on setting the DIP switches.
- When the SK-PS power supply is in an inactive state (control module not active), a trouble on the NAC circuits mapped to TB5 will result in an open circuit condition on the control module output circuit (monitored by an End-of-Line Resistor across Terminals 1 and 4). Additionally, the trouble contacts at TB1 of the power supply can also be used for limited trouble monitoring excluding output faults reporting to Command Input #1. Refer to Section 5 for more information.
- Do not loop wires under screw terminals. Break wires to maintain proper supervision.
- An End-of-Line Resistor must be installed between terminals 1 and 4 for control module wiring supervision (the ELR value is dependent on the module/FACP employed).
- For a list of compatible devices, refer to the *Silent Knight Device Compatibility Document #52612*.
- Refer to the *SLC Wiring Manual* for more information.

B.4 Controlling NACs, Aux Power, and Door Holders with NAC Sync

In this application, use of a single SK-RELAYMON-2 mounted inside the cabinet can monitor the two power supply trouble relays and trigger two independent outputs via relay circuits. SK-PS outputs #1 and #2 are being used for 24 VDC aux power triggered by the module's relay circuits. Any SK-PS output circuit can be configured to follow any input circuit.

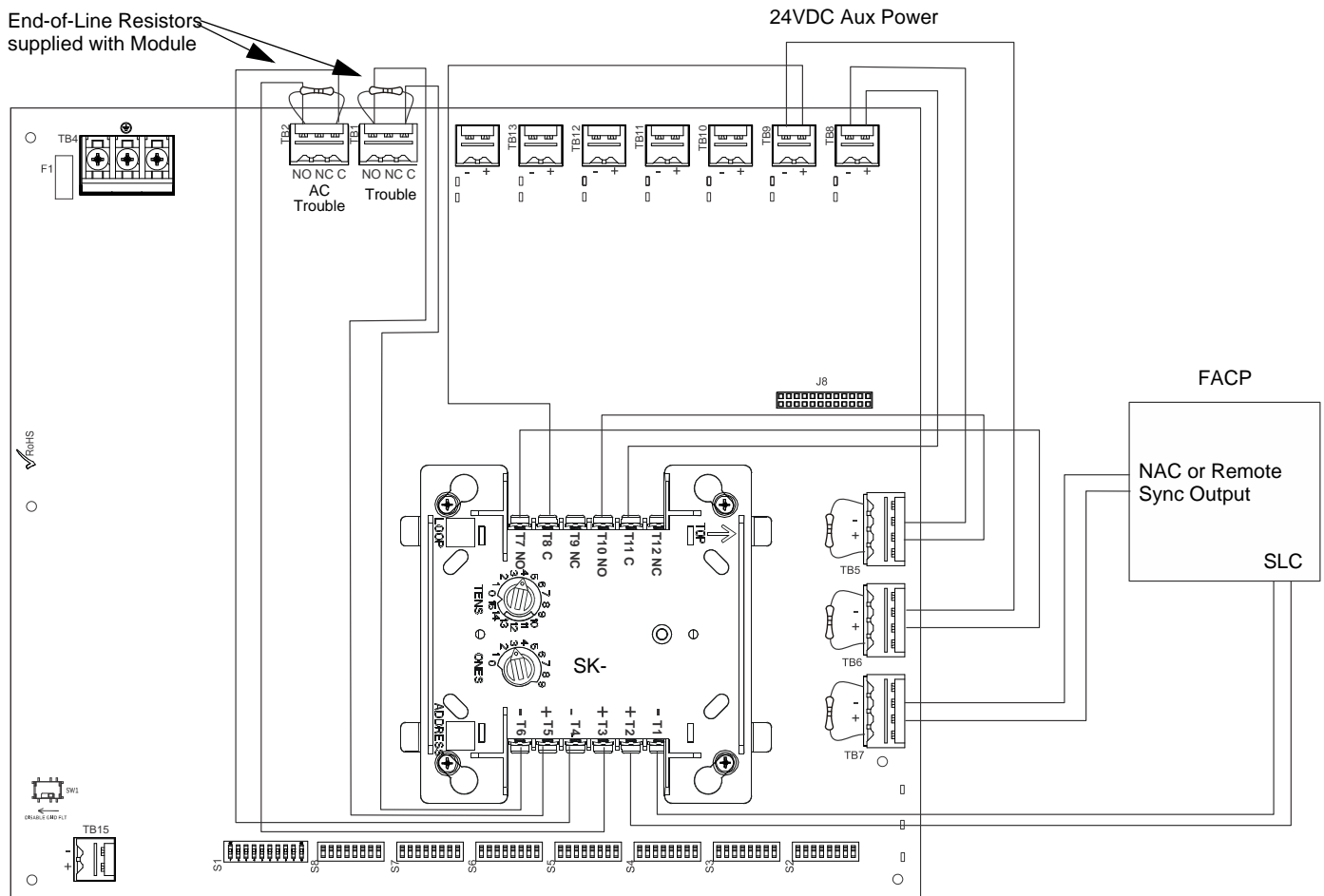

Figure B.4 Controlling NACs, Aux Power, and Door Holders with One Input and NAC Sync

The following notes apply to Figure B.4.

- Any output circuit can be configured as NAC, door holder, or 24VDC power.
- Refer to Section 3 for instructions on setting the DIP switches.
- Do not loop wires under screw terminals. Break wires to maintain proper supervision.
- An End-of-Line Resistor must be installed between terminals 1 and 4 for module wiring supervision (the ELR value is dependent on the module/FACP employed).
- An End-of-line Resistor on input circuits #1-2 (TB5-6) are optional for this particular application.
- Ensure that the SK-RELAYMON-2 is programmed appropriately at the FACP where the inputs are *not* mapped to the same zone as its outputs.
- For a list of compatible devices, refer to the *Silent Knight Device Compatibility Document #52612*.
- Refer to the *SLC Wiring Manual* for more information.

B.5 Controlling all Three Inputs with One Control Module

In this application, all three command inputs are being controlled by one multi-module, the SK-CONTROL-6 mounted inside the cabinet. Output #1 is being used for 24 VDC aux power. Any output circuit may be configured to any input.

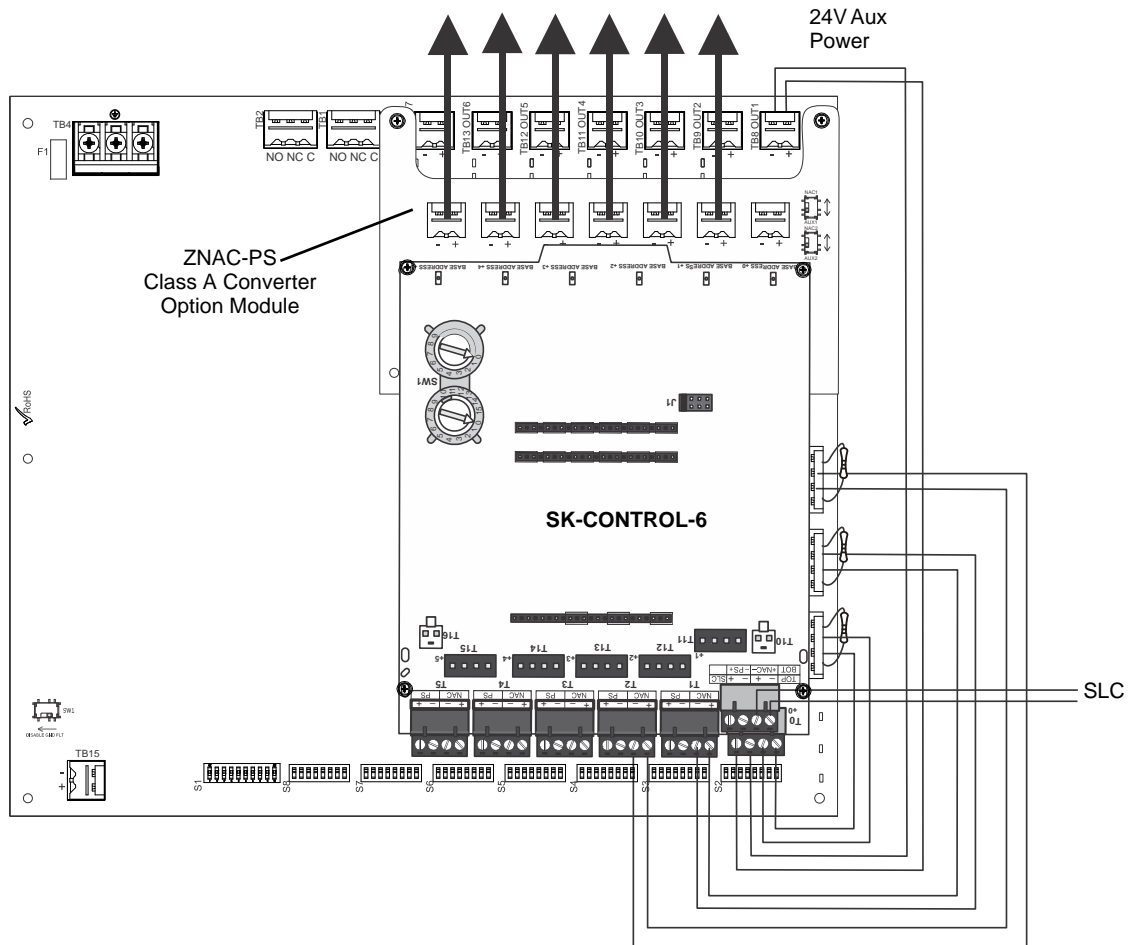

Figure B.5 Controlling Three Inputs with One Module

The following notes apply to Figure B.5.

- An End-of-Line Resistor must be installed between terminals 1 and 4 for control module wiring supervision (the ELR value is dependent on the module/FACP employed).
- Either disable the unused addresses or install ELRs across unused outputs on the SK-CONTROL-6.
- Refer to Section 3 for instructions on setting the DIP switches.
- Do not loop wires under screw terminals. Break wires to maintain proper supervision.
- For a list of compatible devices, refer to the *Silent Knight Device Compatibility Document #52612*.
- Refer to the *SLC Wiring Manual* for more information.

B.6 AC Trouble Reporting with a Conventional FACP

In this application, the SK-PS is being used with a conventional FACP that does not have a type-coded input zone for AC Power loss with a delay. AC Trouble Delay on the SK-PS must be set to none (S1-7 ON, 8 ON). AC Fail delay timers must be set on the DACT. The DACT must be installed in close proximity to the conventional FACP so the audible and visual signaling can be given locally at the FACP as required by UL 864.

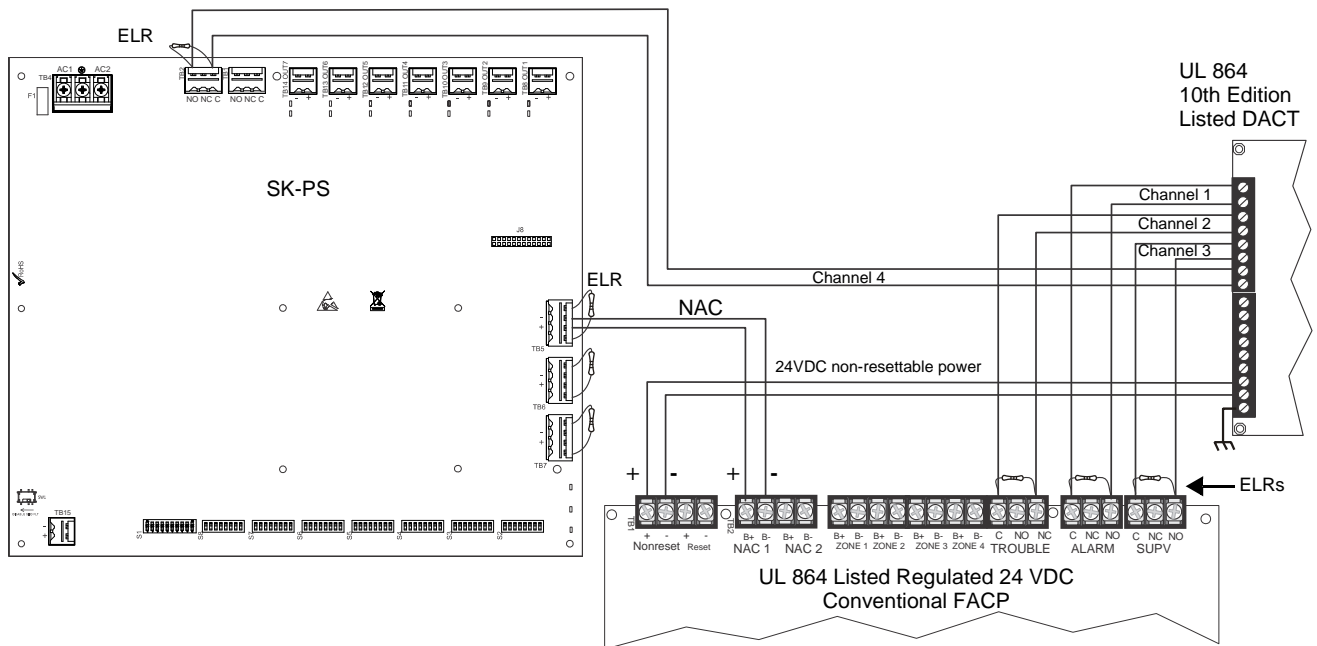

Figure B.6 AC Trouble Reporting with a Conventional FACP

The following notes apply to Figure B.6.

- Wiring from the power supply to the DACT must be in metal conduit within 20 feet of the FACP.
- Refer to Section 3 for instructions on setting the DIP switches.
- Do not loop wires under screw terminals. Break wires to maintain proper supervision.
- An End-of-Line Resistor must be installed between terminals 1 and 4 on the input circuits that require wiring supervision. (The ELR value is dependent on the FACP employed).
- Refer to panel/DACT documentation for programming information.
-

Index

A

AC power **8**
 calculations **31**
 current **8**
 fail **22**
 fail delay **22**
 loss **8**
 loss relay **9**
 loss reporting delay **8, 29**
 loss timer **21**
 voltage **8**
activation
 reverse polarity **8**
alarm condition **8**
applications **8**
aux power **23**
aux power control
 see also resettable or non-resettable power
 24

B

backbox dimensions **12**
battery
 capacity **9**
 charge current **9**
 charger capacity **8**
 float charge voltage **9**
 lead acid **8, 9**
 maximum capacity **8**
 see also secondary power **9**
 trouble **8**

C

cabinet
 see also backbox **12**
capacity
 battery **9**
cascading **18**
charge current
 maximum **9**
 nominal **9**
charger
 enable/disable **22**
charger trouble **8**
circuit board
 layout **10**
Class A Converter Module **13**
 see also ZNAC-PS **8**
Class B **8**
coding
 NAC **8**
command circuit **8**
 current **9**
 see also input circuit **9**
 voltage **9**
command input **22**
compatibility
 input circuit **8**
current
 maximum continuous **8**

 maximum short term **8**
 standby **9**
 total continuous **9**
 total short term **9**

D

debounce/dejitter **21**
dimensions
 backbox **12**
DIP switch
 settings **21, 23**
disable outputs **24**
door holder **24**
 dropout delay **21**

E

ELR **9, 13, 29, 35, 36, 37, 38, 39, 40**

F

factory default **24**
faults **29**
features **8**
filtered power **8**
float charge voltage **9**
form-C
 see also relay **8**

G

ground fault **8, 18**
ground fault detection **8, 9**
 switch SW1 **9**

I

input **22**
 current **9**
 settings **23**
 voltage **9**
input circuit **8**
 activation **8**
 compatibility **8**
 see also control **9**
installation **12**

M

master mode **24**
module
 mounting **14**
mounting
 see also installation **12**
multi-module
 mounting **14**

N

NAC
 activation **8**
 circuit wiring **13**
 Class
 see also NFPA Class **8**

 coding **8**
 output
 see also output circuit **9**
 see also Notification Appliance Circuit **8**
 NEC power-limited wiring requirements **15**
 non-alarm state **8**
 non-resettable power **23, 24**
 notification appliance circuit
 see also NAC **8**

O

operating mode **21, 22**
output
 disable **24**
 unused **24**
output circuit **9**
 Class **9**
 current **9**
 maximum current **8, 9**
 see also NAC output **9**
 types **9**
 voltage rating **9**
output power **8**

P

power
 non-resettable **8**
 resettable **8**
power supply **31**
 board layout drawing **10**
 connectors and switches **10**
power-limited outputs **8**
power-limited wiring **15**

R

relay
 trouble **8, 9, 29**
reporting delay
 AC loss **29**
requirements **31**
resettable power **23, 24**

S

secondary power
 see also battery **9**
selective silence **25**
SK **8**
SK-PS10 **8**
SK-PS6 **8**
slave mode **23, 24**
special operating mode **22**
specifications **8**
startup procedure **9**
strobe synchronization **8**
supervision **8**
 trouble **29**
SW1
 ground fault detection **9**
switch

- SW1 ground fault detection **8, 9**
- sync **24**
- sync mode **22**
- sync type **16, 24, 25**
- synchronization
 - ADA compatible **8**
 - selectable **8**

T

- trouble **29**
 - power supply **8**
 - supervision **29**
- trouble relay **8, 9, 29**
 - contact rating **9**
- trouble supervision **8**

W

- wiring **8**
 - AC power **8**
 - power-limited **15**

Z

- ZNAC-PS **13, 14**
 - see also Class A Converter Module **8**

Manufacturer Warranties and Limitation of Liability

Manufacturer Warranties. Subject to the limitations set forth herein, Manufacturer warrants that the Products manufactured by it in its Northford, Connecticut facility and sold by it to its authorized Distributors shall be free, under normal use and service, from defects in material and workmanship for a period of thirty six months (36) months from the date of manufacture (effective Jan. 1, 2009). The Products manufactured and sold by Manufacturer are date stamped at the time of production. Manufacturer does not warrant Products that are not manufactured by it in its Northford, Connecticut facility but assigns to its Distributor, to the extent possible, any warranty offered by the manufacturer of such product. This warranty shall be void if a Product is altered, serviced or repaired by anyone other than Manufacturer or its authorized Distributors. This warranty shall also be void if there is a failure to maintain the Products and the systems in which they operate in proper working conditions.

MANUFACTURER MAKES NO FURTHER WARRANTIES, AND DISCLAIMS ANY AND ALL OTHER WARRANTIES, EITHER EXPRESSED OR IMPLIED, WITH RESPECT TO THE PRODUCTS, TRADEMARKS, PROGRAMS AND SERVICES RENDERED BY MANUFACTURER INCLUDING WITHOUT LIMITATION, INFRINGEMENT, TITLE, MERCHANTABILITY, OR FITNESS FOR ANY PARTICULAR PURPOSE. MANUFACTURER SHALL NOT BE LIABLE FOR ANY PERSONAL INJURY OR DEATH WHICH MAY ARISE IN THE COURSE OF, OR AS A RESULT OF, PERSONAL, COMMERCIAL OR INDUSTRIAL USES OF ITS PRODUCTS.

This document constitutes the only warranty made by Manufacturer with respect to its products and replaces all previous warranties and is the only warranty made by Manufacturer. No increase or alteration, written or verbal, of the obligation of this warranty is authorized. Manufacturer does not represent that its products will prevent any loss by fire or otherwise.

Warranty Claims. Manufacturer shall replace or repair, at Manufacturer's discretion, each part returned by its authorized Distributor and acknowledged by Manufacturer to be defective, provided that such part shall have been returned to Manufacturer with all charges prepaid and the authorized Distributor has completed Manufacturer's Return Material Authorization form. The replacement part shall come from Manufacturer's stock and may be new or refurbished. THE FOREGOING IS DISTRIBUTOR'S SOLE AND EXCLUSIVE REMEDY IN THE EVENT OF A WARRANTY CLAIM.

Warn-HL-08-2009.fm

Honeywell Silent Knight
12 Clintonville Road
Northford, CT 06472-1610
203.484.7161
www.silentknight.com

LS10227-002SK-E | B | 03-21
©2021 Honeywell International Inc.

Honeywell