

Surface-Type Door Closer

SD-C101-SGQ

Features:

- Grade 1 door closer
- Fits metal or wood doors up to 59" (150cm) wide
- Door weight up to 330-lb (150kg), adjustable for size 1~6
- Two independent valve adjustments for easy setting of sweep and latch speed
- Reversible, non-handed design
- Anodized aluminum body
- Silver finish
- Forged steel arms
- Includes hardware

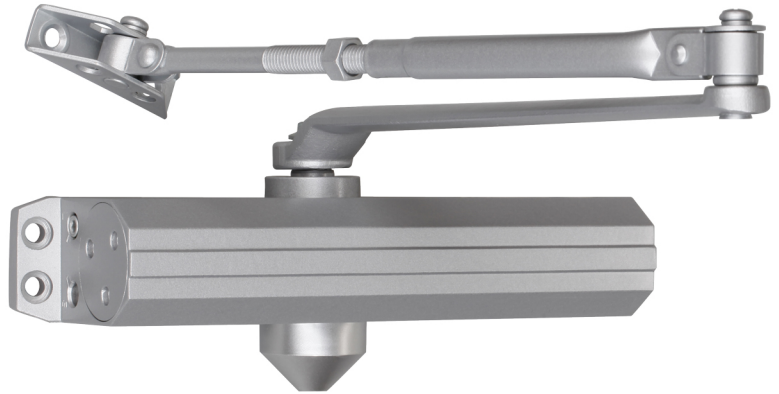

Dimensions:

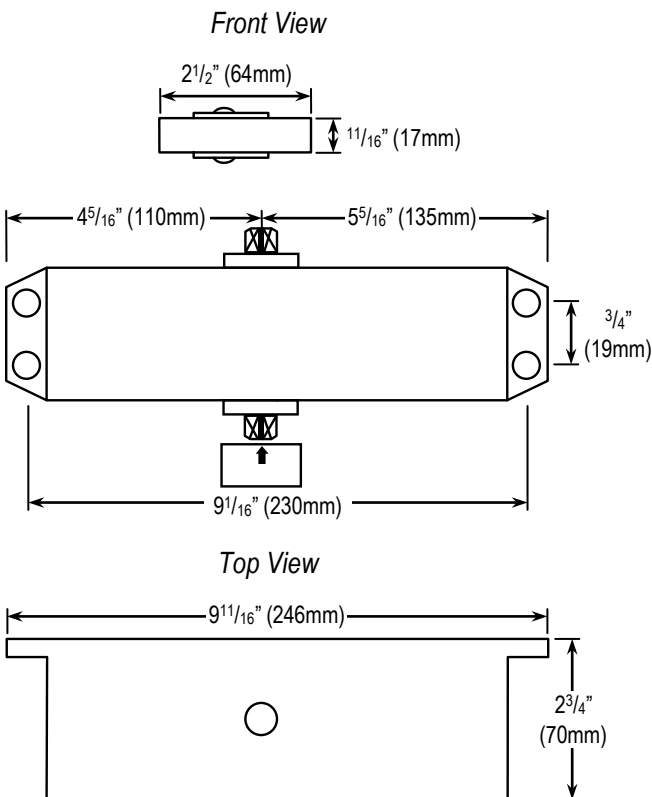

Specifications:

Model	SD-C101-SGQ
Door width	Up to 59" (150cm) wide
Door weight	Up to 330-lb (150kg)
Door type	Metal or wood
Hand	Non-handed
Body	Anodized aluminum
Arm	Forged steel

SECO-LARM® U.S.A., Inc.

16842 Millikan Avenue, Irvine, CA 92606

Phone: (949) 261-2999 | (800) 662-0800 Fax: (949) 261-7326

Website: www.seco-larm.com Email: sales@seco-larm.com

Copyright 2014 © SECO-LARM U.S.A., Inc. All rights reserved.
 All trademarks are the property of SECO-LARM U.S.A., Inc. or their respective owners.
 The SECO-LARM policy is one of continual development. For that reason, SECO-LARM reserves the right to change prices and specifications without notice. SECO-LARM is not responsible for misprints.

SECO-LARM® ENFORCER® CRIMEBUSTER® CBA SLI