



PRODUCT
SANDOR

Product code SANDOR DUAL QUAD ESA
SMA 220V

SANDOR
DUAL QUAD ESA SMA 220V



DOUBLE OPTIC PERIMETER BARRIER

INSTALLATION AND MOUNTING MANUAL VERSION 3.3

Table of contents

1. Introduction.....	3
2. Product description.....	3
3. General warnings.....	4
3.1 Additional warnings for devices powered by mains voltage	
3.2 Installation warnings	
4. List of main components	5
5. Preparation for installation	6
5.1 Preparation of the barrier parts before installation	
5.2 It is advisable to carry out	
6. Examples of mounting/fixing	7
6.1 Placement and installation height	
6.2 Placement and mounting	
7. Evaluations before installation.....	9
7.1 Introduction to barriers	
8. Barrier positioning.....	10
8.1 Precautions before installation	
9. Installation examples	11
9.1 Barrier control	
10. Wiring.....	12
10.1 Type of cable	
10.2 Connecting the cables from the power supply to the barrier	
11. Connections to the terminal board.....	13
11.1 RX Section	
11.2 TX Section	
12. Barrier alignment.....	15
12.1 Calibration using SMA system	
12.2 Alignment	
12.3 Parallel beam calibration	
12.4 Calibration with active crossing function	
13. Basic functions	19
13.1 Basic settings and programming - QUAD B RX board	
14. Intervention time adjustment.....	20
15. Appendix A: motherboard details QUAD B RX	21
15.1 Motherboard components	
15.2 LED indicator operation	
15.3 Characteristics and settings	
16. Appendix B: motherboard details QUAD B TX	24
16.1 Motherboard components	
16.2 LED indicator operation	
16.3 Characteristics and settings	
17. Appendix C: configuration of optical boards	26
17.1 Transmitter optic	
17.2 Receiver optic	
18. Appendix D: wiring kit 220V connections	29
19. Technical specifications	29
20. FAQ.....	30
21. Product disposal	32



1. Introduction

Congratulations on having purchased the Politec perimeter barrier. This appliance guarantees long-lasting and reliable operation if installed correctly. For correct and effective use, it is necessary to read this instruction manual carefully.



The system has been designed to detect intrusions and activate the alarm; it is not a device that prevents intrusion. Politec is not responsible for damage, injury or loss caused by accidents, theft, force majeure (including momentary lightning-induced overcurrent), abuse, improper or incorrect use, faulty installation or inadequate maintenance.

2. Product description

The double optic infrared perimeter barrier consists of an infrared receiver and transmitter. Operation is based on "AND" logical operations: in other words, the alarm is activated only in the event of simultaneous interruption of two superimposed beams.

N.B.: These barriers use optical synchronism. The receiver must see ONLY and exclusively its transmitter. MUST NOT see signals from other barriers, IR lights such as photocells or flashing lights. It is not recommended for use in indoor applications where there are many reflections and light sources

This barrier is ideal for perimeter protection of internal and external areas.

It is equipped with a system for selecting the operating frequency that allows you to install multiple barriers on the same site without them interfering with each other. The main features of this barrier are:

- Adjustable intervention time which allows you to adapt to the characteristics of the site to be protected;
- Protection beam angle adjustment both vertically and horizontally;
- Set-up for mounting on a wall, on a pole and on aluminium columns;
- Optical alignment with viewfinder and signal measurement points;
- Contact signalling barrier opening.

Warnings



Mounting, installation of the barrier and connection to the mains must be carried out by expert and qualified personnel, in compliance with rules and regulations applicable to electrical systems.

3.General warnings

This installation manual contains important information regarding safety for installation: it is necessary to read all the instructions before proceeding with the installation.

Keep this manual for future use.

- If you have any questions or doubts during installation, do not carry out any operations and contact the support service.
- Use of these products for purposes other than those specified in these instructions is prohibited.
- You must not make any changes to the components of the product unless stated in the manual in order not to void the warranty; such operations can only lead to malfunctions; Politec assumes no liability for malfunctions or damage due to modified products.
- Depending on the specific situation of use, check for the need for additional devices: detectors or signalling devices.
- During installation, mounting and use of the product, make sure no foreign objects (solids, metals or liquids) are able to penetrate inside the open devices.
- Manufacturer's liability:Politec assumes no liability for failures resulting from incorrect installation; lack of maintenance, incorrect assembly or use.
- Politec is also not liable for incorrect or incomplete operation of the product or failure to detect intrusion.
- Warranty (summary of conditions):Politec guarantees its products for a period of 2 years from the production date.The warranty is applied to those purchasing directly from Politec; there is no warranty for the end user who, in the event of breakdowns or faults, must contact the installer or dealer.
- The warranty excludes aesthetic parts as well as parts subject to normal wear and parts subject to normal consumption such as batteries and accumulators.

3.1 Additional warnings for devices powered by mains voltage

This manual is intended only for technical personnel qualified to install such devices.

- Assessing the hazards that may occur during installation and use of the system, in order to achieve complete safety, it is necessary that installation takes place in full compliance with applicable laws, methods, rules and regulations.
- Before accessing the internal terminals of the product, it is necessary to disconnect all the power circuits.
- If automatic circuit breakers or fuses trip, before resetting them it is necessary to identify the fault and repair it.

3.2 Installation warnings

- Check that all the material to be used is in excellent condition and suitable for use.
- Before proceeding with the installation, check the environmental class of the products in the "technical specifications" chapter.
- Check, by comparing with the values shown in the paragraph "technical specifications", that the range of the devices is equal to or lower than the physical distance between the barriers.
- Check that the barrier is positioned in areas protected against potential impact, in flat areas and on fixed supports to avoid oscillations.
- Do not place the system components close to heat sources as they could be damaged.
- Each barrier has its own operating principle: check the instructions for choosing the right position in the respective instruction manual.



4.List of main components

The package contains the following components and accessories.

When opening the package, check that everything has been included.

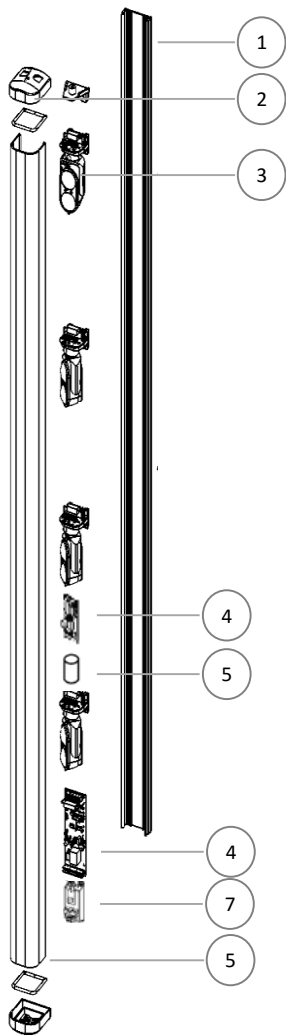

No.	COMPONENT
1	Aluminium profile
2	Caps
3	Transmitter\Receiver optics
4	Control Board 220V
5	Rechargeable Lithium Battery 14.8V 2Ah
6	QUAD B RX / TX motherboard
7	Power supplier 12V
8	Black polycarbonate cover

5. Preparation for installation

5.1 Preparation of the barrier parts before installation

Since the communication between the barriers can take place wired, via wireless and their alignment can be done optically, it is advisable to firstly check all the component parts of the barriers and any accessories before beginning the installation.

5.2 It is advisable to carry out:

- device configuration on a table;
- a check on the operation of the optical and acoustic alignment
- the permanent fixing of each device;
- the preparation and carrying out of electrical connections.

In order to avoid errors, operating and installation problems, it is advisable to proceed as follows:

- a) Place all the products with the package open on a table;
- b) For the low consumption barrier version for wireless models with universal circuit board housing, insert and connect the radio transmitter, and connect it to the barrier receiver board
- c) Power up the barriers and program them
- d) Test barrier operation;
- e) Place (without fixing) the barriers at the planned points;
- f) Place (without fixing) all the other devices at the planned points;
- g) Check for each barrier that there is sufficient field for radio communication (for wireless versions);
- h) Permanently fix the barriers.

Before proceeding with the installation, it is necessary to check the integrity of the product, the adequacy of the model chosen and the suitability of the environment intended for installation:

- Check that all conditions of use fall within the "limits of use" and in the "Technical specifications of the product".
- Check that the environment chosen for the installation is compatible with the total footprint of the product.
- Check that the surface chosen for the installation of the product is sturdy so as to ensure stable fixing and that it is adequately protected against possible impacts or the elements.



6.Examples of mounting/fixing

6.1 Placement and installation height

Position the barrier considering the type of surrounding environment and the protection distance for correct and effective operation.

Position it in such a way that there are no obstacles in its range of action (trees/plants or objects that can swing or move with the wind or rain).

Position the barrier so that sunlight does not hit it directly near the RX sensors.

In any case, it is necessary to take into consideration the specific beam diffusion of each model, to avoid reflection of the beams caused by the ground or by adjacent objects.

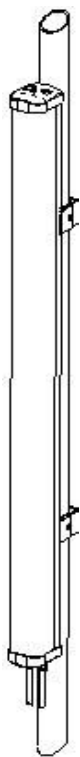

**Pole mounting
with SAN/PL
brackets**

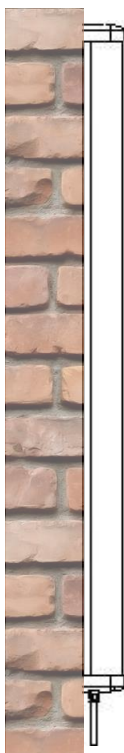

**Wall mounting with
SAN/SD brackets**

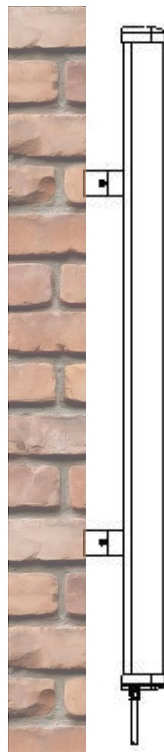

**Wall mounting with
SAN/PL pole brackets
(recommended for
protection of sections
along the wall)**

6.2 Placement and mounting

It is strongly recommended to always request and use the accessory brackets for fixing the columns, avoiding to make holes in the aluminium structure.

Pole mounting with SAN/PL

SAN/PL brackets allow fixing on poles type SAN/TB1 and SAN/TB2 with a diameter of 48 - 50mm in a very simple way as seen in the figure.

- Each column requires a minimum of 2 brackets or more if the column is very tall.
- The poles are equipped with a base for fixing to the floor or to the POB30 cable pit to be cemented into the ground, also with the function of branch junction box.
- The connection cables enter from the lower cover of the column, equipped with O rings and cable glands.

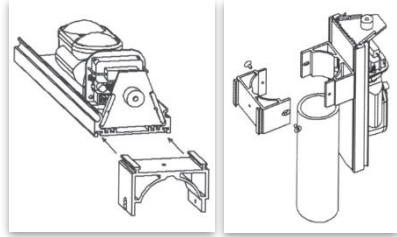

Wall mounting with SAN/PL

The SAN/PL brackets also allow fixing to the wall, in a very simple way as seen in the figure.

- It is recommended to use these, when protecting windows, doors, etc., along the wall, in order to avoid small obstacles, such as hinges, edges of the windowsills, which could be in the beams creating an attenuation of the signal.
- Each column requires a minimum of 2 brackets or more if the column is very tall.

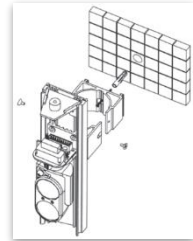

Wall mounting with SAN/SD

The SAN/SD brackets supplied in a kit of 2 pieces allow wall mounting and are invisible, as seen in the figure.

- These brackets are recommended when the columns are placed in front of each other or the internal optics are rotated to less than 90° horizontally.
- Each column requires a kit consisting of two brackets, which are fixed to the ends of the column, leaving only the holes for wall fixing visible.
- Once all the installation and functional operations have been completed, the two covers will hide the part with the fixing holes.

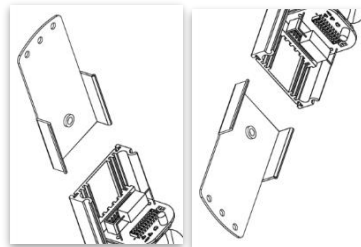

WARNING:

Product warranty is invalid if there is any hole in the aluminium profile or any component

7. Evaluations before installation

7.1 Introduction to barriers

The Active Infrared Barrier is characterised by two components, a TX transmitter that emits a pulsed infrared signal towards the RX receiver. This signal is constantly controlled by a **CODED SYNCHRONISM** which can be **WIRED or OPTICAL** according to the different types of barriers.

The transmitted infrared beam takes on a conical shape: the greater the distance between TX and RX, the greater the diameter of the cone when it arrives.

View from above

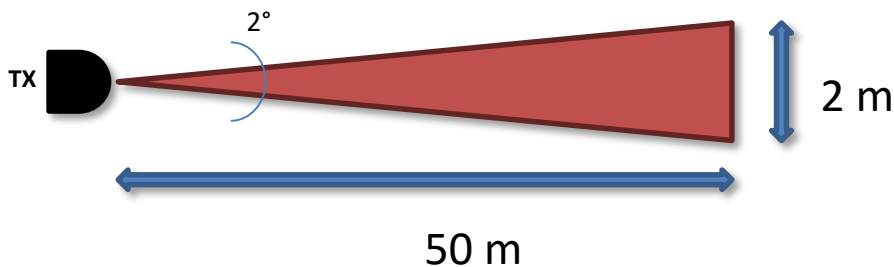

Signal interruption:ALARM

A barrier can be composed of several TX transmitters and RX receivers mounted inside specific different columns.

The infrared barriers have multiple controls that significantly limit false alarms, as the genuine alarm signal is given by the complete interruption of the infrared signal.

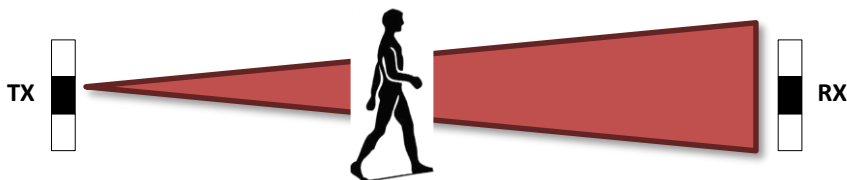

POWER SUPPLY

The barriers can be divided into two categories, powered at low voltage and connected by wire, or powered by batteries for Wireless systems, then combined with radio transmitters to communicate with the alarm control unit, as required by specific sector regulations.

HEATERS

It is recommended to power the thermostating system as, in conditions of high humidity, the condensation that is created on the screen can lead to a significant decrease in the IR signal up to the alarm. For obvious reasons, for battery powered barriers, there is no thermostat control even if set up, therefore to minimise the problem, it is necessary to reduce the working distance between TX and RX, thereby ensuring a good amount of signal constantly, even in case of particular climatic conditions.

8. Barrier positioning

8.1 Precautions before installation

In order to avoid false alarms, it is advisable to place the barriers away from reflecting surfaces, away from walls or anything that can attenuate the signal.

DO NOT place the barriers if there are plants, bushes or fixed objects in the range that obstruct the signal and create "grey areas". Leave a corridor of 50cm for distances between columns greater than 50m

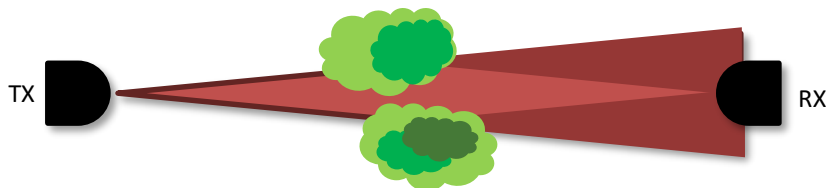

DO NOT place the barriers close to walls, without spacing the columns with adequate brackets, as the signal quality may decrease

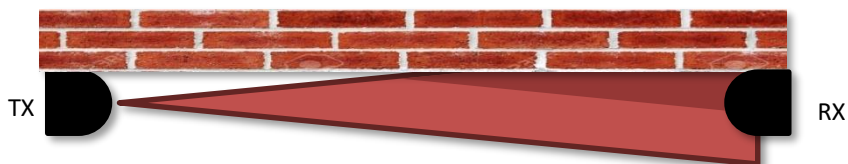

DO NOT place barriers close to roads: vehicle lights directed towards the RX could create disturbances

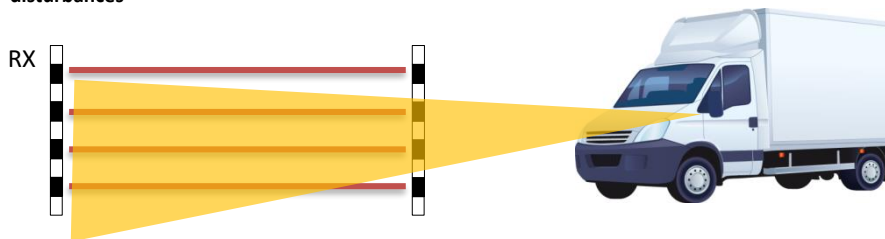

DO NOT place barriers near automatic gates: photocell signals can create interference.

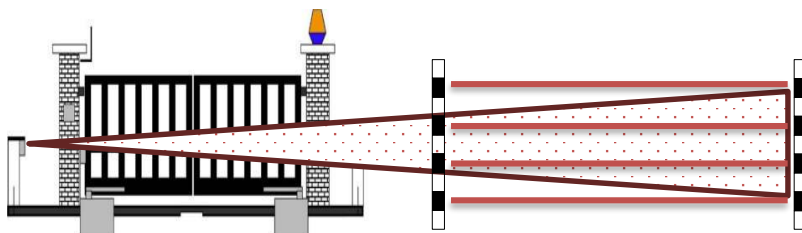

9. Installation examples

9.1 Barrier positioning

In addition to standard products, all Politec products can be customised according to the installation needs including height of the columns, number of beams inside and the different ways they are arranged.

This barrier, always composed of a TX column and an RX column, lends itself well to single barrier systems and for the protection of facades, as well as in the open field, observing the necessary precautions, given by their characteristics (e.g. optical synchronism, power supply and working distances).

To avoid interference between barriers, position the columns so that each receiver only sees its transmitter.

N.B.: Use this layout also for barriers on facades on surfaces at different heights

Arrangement of barriers according to protection needs.

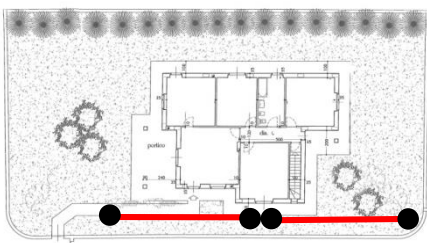

Contiguous single barrier system



Single barrier system

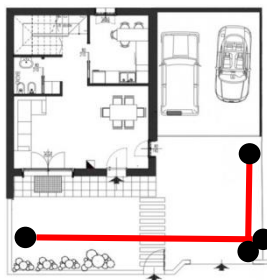

Crossed single barrier systems

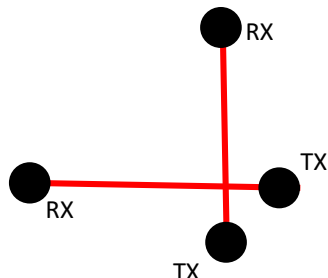

10.Wiring

The wiring must be done using two separate cables.

The first of the electric type (eg 3x1.5 mm²) to be connected to the power supply via a fuse holder

The second, necessarily of the SHIELDED type (ex. Nx0.22 mm² minimum) to transfer all outgoing signals to the alarm control unit, as well as the connection of the synchronism between the columns, otherwise made with a dedicated cable but always shielded.

N.B. The shield of this cable must be connected to the 12 Vdc negative of all columns.



Power Line cable



Signals

11.Connections to the terminal board

11.1 RX Section QUAD B RX Motherboard

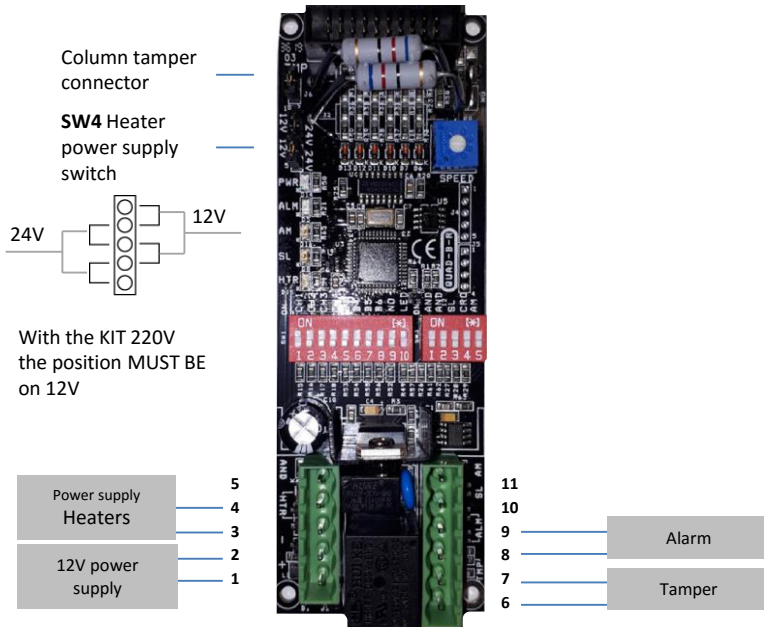

12 Vdc for command AND RANDOM remotely	AND	5	11	AM	Antimask - O.C. output:NO to GND
Heater power supply 24/12 Vac (or Vdc)	HTR	4	10	SL	Disqualification - O.C. output:NO to GND
Heater power supply 24/12 Vac (or Vdc)	HTR	3	9	ALM	NC alarm output
GND	-	2	8	ALM	NC alarm output
Power supply +12/30 Vdc	+	1	7	TMP	Tamper output
			6	TMP	Tamper output



11.2 TX Section QUAD B TX Motherboard

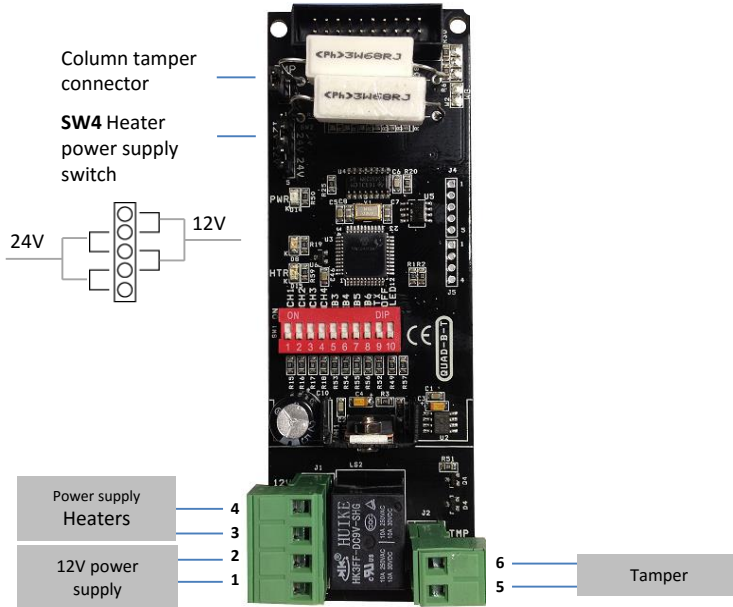

Heater power supply 24/12 Vac (or Vdc)	HTR	4			
Heater power supply 24/12 Vac (or Vdc)	HTR	3			
GND	-	2	6	TMP	Tamper output
Power supply +12/30 Vdc	+	1	5	TMP	Tamper output

12.Barrier alignment

For correct alignment, once the barriers are installed, orient the optical units of the transmitters and the optical units of the receivers towards each other, adjusting the lens holder horizontally manually, after having loosened the locking screw on the joint and vertically through the front screw located to the left of the lens.

Vertical orientation

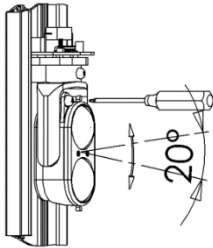

Horizontal orientation

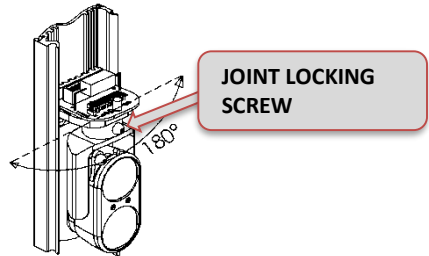

N.B.: Tighten the joint locking screw after the adjustment

12.1 Calibration using SMA system

It is possible to improve the calibration by using the supplied filter.

1. Fold the device following the pre-set folds.

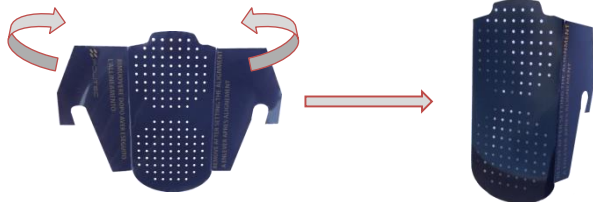

2. Position the filter in front of the TX optic inserting the two hooks on the pins of the optic fork. The filter is designed to refine the search for the alignment signal under adverse conditions.



It is sufficient to apply the filter only on the TX, there is no need to repeat the operation also on the RX.

12.2 Alignment

- Power the unit electrically
- Starting from the Receiving column, press the TEST button on the first RX optic for 3 seconds or until the buzzer emits an intermittent acoustic signal, accompanied by the equally intermittent flashing of the long-range high-intensity LEDs.

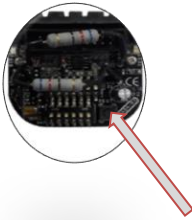

- Press the TEST button on the TX optic of the corresponding column for 5 seconds, in this case only the orange TEST LED will light up.
- Orient the TX optic towards the RX optic, vertically and horizontally acting as explained above, until you find the maximum alignment.

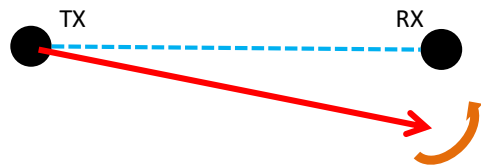

- The maximum alignment condition will be reached when the high-intensity LEDs are on steady and the buzzer will emit a continuous sound, for this reason, it may be necessary to make minor adjustments also on the RX optic.

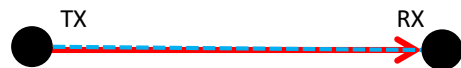

N.B.: the fixed buzzer sound has a maximum duration of 3 minutes. To obtain a good alignment it is necessary to complete a FULL rotation on the horizontal axis of the RECEIVER optic, thereby performing the SCANNING of the optical signal. This operation is very useful to understand if the alignment of the optics is taking place directly on the same axis and not through reflection, therefore deceptive, because the signal value is much lower, despite having reached the hypothetical maximum alignment signal.

- The partial or total misalignment condition is signalled by the infrequent flashing of the LEDs and by the non-continuous whistle of the buzzer.
- After calibration, tighten the horizontal adjustment screw, and exit the test function by pressing the TEST button on the TX and RX optics for 3 seconds.
- Repeat all the operations on each beam of the barrier.

At the end of the operation, remove the screen which acts as an attenuator, making sure to have found the optimal value.

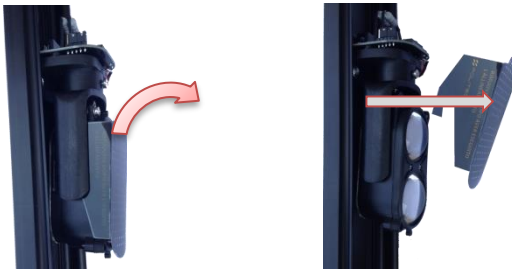

N.B.: Optical synchronism requires greater attention during the installation phases, in particular, that the receiving column is not affected by other sources of IR light.

To be absolutely certain that the alignment of the optics is correct (and therefore no false alignments due to the transmission of other infrared sources, such as other barriers of the same system as well as gate photocells) cover the TRANSMITTER optic with your hand: if the RECEIVER continues to give a continuous beep, it means that it sees another infrared source that must be turned off and eliminated.



12.3 Parallel beam calibration

Test the TX1 and RX1 optics on the respective columns and proceed with the calibration as explained. Then repeat the operation for each pair of optics.

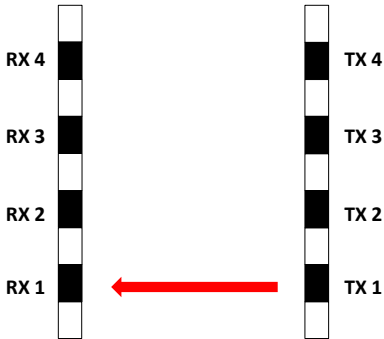

N.B.: During the alignment test phase, the activation of a TX transmitter determines the automatic shutdown of the other TX optics in the column.

12.4 Calibration with active crossing function

To activate the function, set DIP 4 to ON on the 5 DIP SWITCH unit of the QUAD B RX

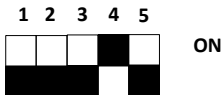

Test the TX1 and RX1 optics and proceed with the calibration as explained but, having found the maximum alignment, keep the TX1 optic in test and exit the test only with RX1, then repeat the same operations with RX2, RX3 and RX4 (QUAD) + RX5 and RX6 (ESA).

At the end, exit the test of TX1 and repeat the operation for each TX optic on each RX.

At the end of all operations, make sure that TX1 and TX4 or TX6, the ends and most susceptible to orientation movements, are still optimally aligned with the corresponding RX1 and RX4 or RX6.

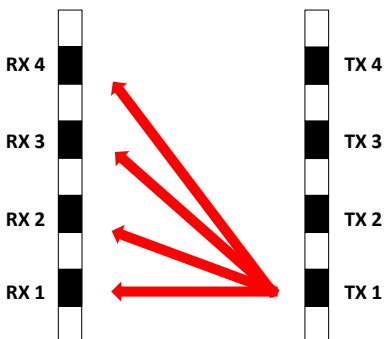

WARNING: too close a distance between the TX and RX columns does not allow calibration with the crossing function.

Furthermore, this function significantly increases sensitivity and is used to intercept the approach to the barrier, not the crossing. For this reason, it is recommended to use this function only in INDOOR applications

13. Basic functions

13.1 Basic settings and programming - QUAD B RX board

LED INDICATORS

- POWER - Lit if powered
- ALM - Lit if the barrier is in alarm
- AM - Lit if receiving IR interference

10 DIP SWITCH UNIT FOR BEAM SELECTION

SEE SPECIFICATIONS IN
CHAP 15.3



INTERVENTION TIME ADJUSTMENT TRIMMER

5 DIP SWITCH UNIT FOR CONFIGURATIONS

- AND RANDOM: DIP 2
- DISQUALIFICATION:
DIP 3

14. Intervention time adjustment

On the QUAD B RX motherboard there is a potentiometer to adjust the INTERVENTION TIME. In particular, it is possible to set the barrier for rapid (crossing while running) or slow (crossing while walking) alarms.

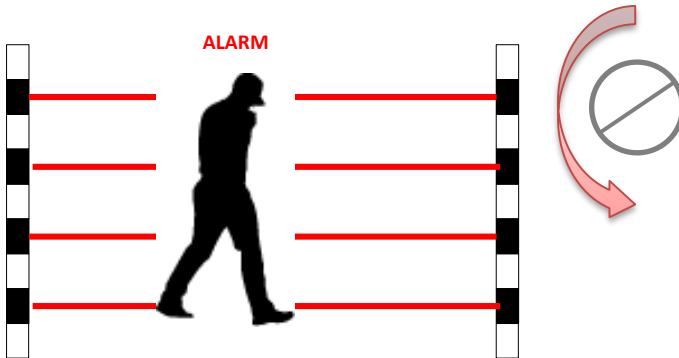

By adjusting the potentiometer anticlockwise, the intervention time is increased up to 500ms. In this condition, the alarm of a person crossing the barrier while walking is guaranteed, with the advantage of excluding the possibility of any false alarms (e.g. animal crossing).

By adjusting the potentiometer clockwise, the intervention time decreases up to 50ms. In this condition, an alarm is guaranteed for a person crossing the barrier running at maximum speed.

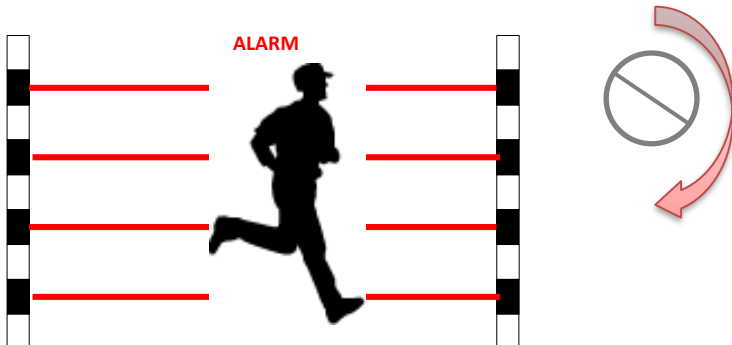

15. Appendix A: QUAD B RX motherboard details

15.1 Motherboard components

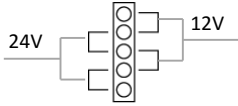

SW4 Heater power supply switch

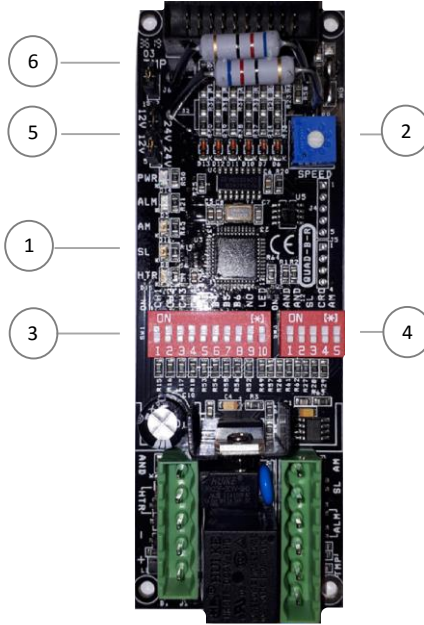

1	POWER SUPPLY LED	PWR	Green
	ALARM LED	ALM	Red
	MASKING LED	AM	Green
	DISQUALIFICATION LED	SL	Green
	HEATERS LED	HTR	Yellow
2	TRIMMER	Intervention time adjustment	
3	10 DIP SWITCH UNIT	Channel and beam selector	
4	5 DIP SWITCH UNIT	Function selector	
5	SW4 JUMPER	Heater power supply switch	
6	TAMPER	Column tamper connection	

15.2 LED indicator operation

The QUAD B RX motherboard has five control LED indicators, which can be activated by setting DIP 10 on the unit with 10 on the board to ON.

At the end of the test it is advisable to reposition the DIP on OFF, both to avoid catching the signals and to reduce system consumption.

<p>PWR LED <i>Power supply on LED</i></p>	<p>The POWER LED is the only one that is always on in normal operating conditions, it confirms that the board is correctly powered.</p>
<p>ALM LED <i>Alarm LED</i></p>	<p>Normally off, if lit, it indicates the alarm status. The alarm condition will depend on the setting of the jumpers making up the board and on the intervention delay set on the trimmer SPEED which will be adjustable from a minimum of 50 mSec to 500 mSec. Increases clockwise.</p>
<p>AM LED <i>Masking <u>signal</u></i></p>	<p>The lighting up of the AM LED indicates the presence of an unwanted modulated infrared signal. ANTIMASK can be signalled on the terminal board in the presence of an attempt at masking N.B.: Under normal operating conditions, the LED must remain off. If it remains on or flashing, check the correct setting of the beam selection jumpers on the various transmitters.</p>
<p>SL LED <i>Low signal (<u>disqualification</u>)</i></p>	<p>The lighting up of the SL LED indicates the presence of THICK FOG. In the presence of thick fog, before having an alarm condition due to lack of signal, the SIG LOW LED lights up and the DISQUALIFICATION signal can be displayed on the terminal board N.B.: By inserting the jumper SIG LOW in the ON position, and with the disqualification intervention, the barrier is excluded, which will become operational again as soon as the fog has cleared.</p>
<p>HTR LED <i>LED confirming that the heating system is on</i></p>	<p>Electronically controlled automatic heating system to guarantee an internal temperature between 17°C and 22°C under all climatic conditions. Normally off, when on the heating is active.</p>



15.3 Characteristics of settings

N.B.By default the QUAD barriers with 4TX and 4RX or ESA with 6TX and 6RX, therefore in standard configuration, are set during the factory testing phase.If it is necessary to change the original number of Beams in the field, it is necessary to correctly set the DIP SWITCHES from 5 to 8 on the 10 unit of the QUAD B RX and QUAD B TX motherboard.

On the QUAD B RX motherboard, it is possible to configure different functional conditions, using the 10 and 5 DIP SWITCH units.

10 DIP SWITCH UNIT

1	CH1	Transmission channel 1
2	CH2	Transmitting channel 2
3	CH3	Transmission channel 3
4	CH4	Transmission channel 4
5	BEAM 3	The first 3 RXs are active
6	BEAM 4	The first 4 RXs are active
7	BEAM 5	The first 5 RXs are active
8	BEAM 6	The 6 RXs are active
9	NO	In ON the alarm relay switches to NO when at rest, Otherwise the relay is NC
10	LED	In ON the LED indicator on the board is turned on.

DUAL VERSION: Dip 5-6-7-8 in OFF the barrier works with the first 2 beams

5 DIP SWITCH UNIT

1	AND	In ON the barrier goes into alarm with at least 2 interrupted RX beams
2	AND 1-2	In ON the barrier goes into alarm in AND with the two RX lower beams and in OR with the remaining ones. WARNING:DIPs 1 and 2 cannot both be active
3	DISQ	In ON the fog "DISQUALIFICATION" function is activated.In case of fog the barrier is inhibited, blocking the alarm relay.It self-restores as soon as the fog has cleared.The condition information can be transferred from the output of the dedicated terminal.
4	CRO	In ON the cross beam function is activated.
5	AMK	In ON the "ANTIMASK" and IR filter function is activated.The condition information can be transferred from the output of the dedicated terminal.



16. Appendix B: QUAD B TX motherboard details

16.1 Motherboard components

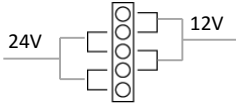

SW4 Heater power supply switch

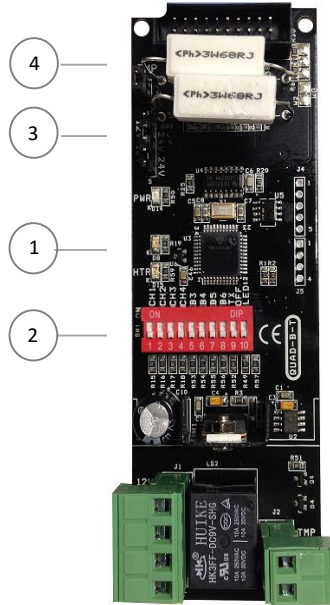

1	POWER SUPPLY LED	PWR	Green
	HEATERS LED	HTR	Yellow
2	10 DIP SWITCH UNIT	Channel and beam selector	
3	SW4 JUMPER	Heater power supply switch	
4	TAMPER	Column tamper connection	

16.2 LED indicator operation

The QUAD B TX motherboard has two control LED indicators, which can be activated by setting DIP 10 on the unit with 10 on the board to ON.

At the end of the test it is advisable to reposition the DIP on OFF, both to avoid catching the signals and to reduce system consumption.

POWER <i>Power supply on LED</i>	The POWER LED is the only one that is always on in normal operating conditions, it confirms that the board is correctly powered.
HTR LED <i>LED confirming that the heating system is on</i>	Electronically controlled automatic heating system to guarantee an internal temperature between 17°C and 22°C under all climatic conditions. Normally off, when on the heating is active.

16.3 Characteristics of settings

On the QUAD B TX motherboard, it is possible to configure different functional conditions, using the 10 DIP SWITCH unit.

10 DIP SWITCH UNIT

1	CH1	Transmission channel 1
2	CH2	Transmitting channel 2
3	CH3	Transmission channel 3
4	CH4	Transmission channel 4
5	BEAM 3	The first 3 TXs are active
6	BEAM 4	The first 4 TXs are active
7	BEAM 5	The first 5 TXs are active
8	BEAM 6	The 6 TXs are active
9	TX OFF	In ON it disables all the transmitters. It is a useful function for checking the presence of external IR interference during the alignment phases
10	LED	In ON the LED indicator on the board is turned on.

DUAL VERSION: Dip 5-6-7-8 in OFF the barrier works with the first 2 beams



17. Appendix C: configuration of optical boards

17.1 Transmitter optic.

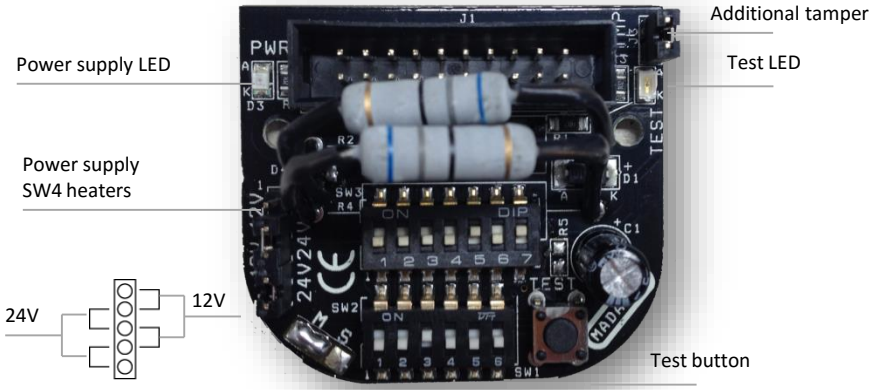

With the KIT 220V the position MUST BE on 12V

	1	2	3	4	5	6	7	1	2	3	4	5	6	
QUAD version	TX6	Black	Black	Black	Black	Black	Black	White	White	White	White	White	White	ON
	TX5	White	White	White	White	White	White	Black	Black	Black	Black	Black	Black	ON
	TX4	Black	White	Black	White	Black	White	Black	White	Black	White	Black	White	ON
	TX3	White	Black	White	Black	White	Black	White	Black	White	Black	White	Black	ON
	TX2	Black	White	Black	White	Black	White	Black	White	Black	White	Black	White	ON
	TX1	White	Black	White	Black	White	Black	White	Black	White	Black	White	Black	ON
														ESa version
														DUAL Version

With DIP 7 in ON (as default) and with the power supply LED on, the TX optic functioning is verified. The power supply of the heaters is set by default to 24V; 12V can be used by changing the jumper configuration (SW4) on all optics and on the QUAD B TX board. The voltage can be both AC and DC.

N.B.:The settings relating to the addressing are already set by default.



17.2 Receiver optic.

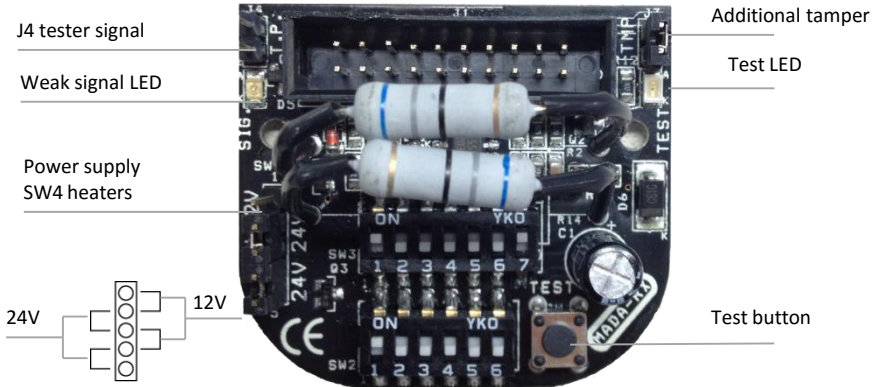

With the KIT 220V the position MUST BE on 12V

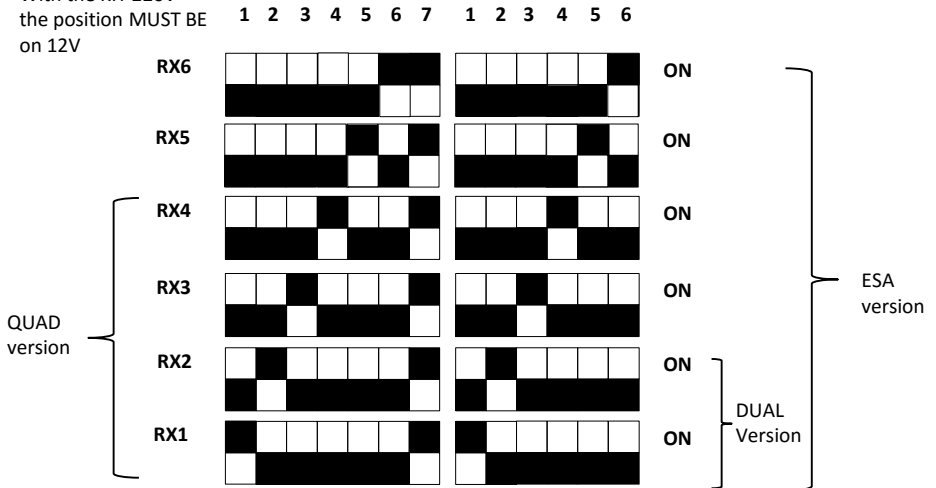

With DIP 7 in ON (as default) and with the power supply LED on, the TX optic functioning is verified. The power supply of the heaters is set by default to 24V; 12V can be used by changing the jumper configuration (SW4) on all optics and on the QUAD B RX board.

The voltage can be both AC and DC. Jumper J4 reads the value of the alignment signal, expressed in volts.

N.B.:The settings relating to the addressing are already set by default.

N.B.:The barrier can result in an alarm even if the WEAK SIGNAL LED is off. The cause may be the lack of synchronism or a misaligned transmitter.



18. Appendix D: wiring kit 220V connections

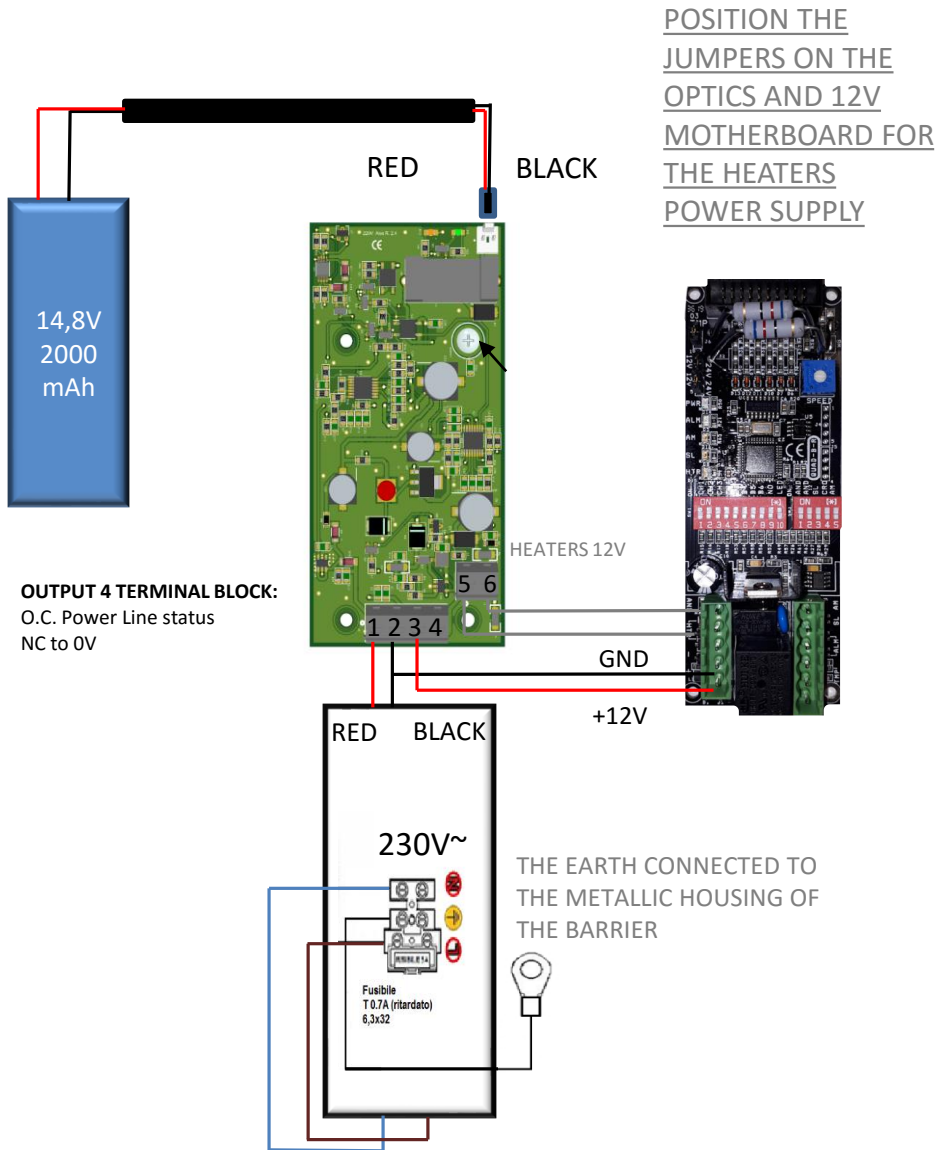

18. Technical specifications

OUTDOOR RANGE	1-100 m
INDOOR RANGE	1-200 m
SYNCHRONISATION	Optical
OPTICAL SENSORS	Double optics with pulsed beams 950 nm
CALIBRATION	Parallel or crossed beams
DISQUALIFICATION	Automatic, if enabled, with external signalling, O.C.:NO to GND
MASKING	Automatic, if enabled, with external signalling, O.C.:NO to GND
OPERATING TEMPERATURE	- 25°C / + 65°C. Heater kit available for temperatures down to -50°C
ALIGNMENT ANGLES	20° Vertical - 180° horizontal
DETECTION SYSTEM	OR / AND 1st and 2nd / AND random
REMOTE CONTROL	AND Random
EXTERNAL SCREEN	Infrared with UV filter
OUTPUTS	Alarm and tamper relay
PROFILE DIMENSIONS WxDxH	60mm x 60mm x from 1000mm to 4000mm
AMBIENTAL CLASS	CLASS 4
WARRANTY	2 years

STANDARD MODELS

2 TX +2 RX | DUAL PAIR

4 TX +4 RX | QUAD PAIR

6 TX + 6 RX | ESA PAIR

	2TX + 2RX	4TX + 4RX	6TX + 6RX
Total beams	2TX + 2RX	4TX + 4RX	6TX + 6RX
Power supply	110 – 220 Vac	110 – 220 Vac	110 – 220 Vac
Consumption per pair	105 mA	120 mA	135 mA
Column internal heaters	30W with thermostat	50W with thermostat	70W with thermostat



19.FAQ

I can't align	<p>Check that there are no obstacles of any kind interposed between RX and TX and that the conditions of the site do not represent an impediment;</p> <p><u>N.B. remember to reactivate the optics once the alignment operation is finished.</u></p>
	<p>Make sure that the TX is in the test phase (orange LED of the optic in question on and the others off);</p>
	<p>Make sure that the connectors are well inserted and that the DIP configuration is correct;</p>
	<p>Check that the power supply on the terminal board is sufficient;</p>
	<p>Use the shielded cable for the power supply by connecting the braiding to the earth (in case of persistent problem, it is recommended to connect the alarm and power supply/tamper with two separate shielded cables);</p>
	<p>Check the correct sizing of the power cables;</p>
	<p>Make sure there are no external light sources that interfere with the correct reading of the signal (gate photocells, other barriers, infrared etc.);</p>
The system goes into disqualification even in the absence of fog	<p>For more precise alignment, position one side of the column cover in front of the lenses in order to have two surfaces interposed between TX and RX to double the attenuation of the beam.</p>
	<p>Check the alignment accuracy of each individual optic and, if necessary, carry out the procedure by performing a complete scan, making sure that there are no light sources that can influence the calibration;</p>



After accurately aligning the sensor (LED light on steady and continuous BEEP) the system remains in alarm	Make sure that there are no external light sources that interfere with the correct reading of the signal (gate photocells, other barriers, infrared etc.), to do this it is possible to check when switching off the transmitter that the receivers have the alarm lights on, if this is not the case, find the light source and eliminate it.
	Make sure that the connectors are well inserted and that the DIP configuration is correct;
	Check which receiver optic does not pick up the corresponding transmitter. To do this set the AND mode, if the barrier is no longer in alarm, obscure each beam individually finding the one that does not generate the general alarm, this beam is not aligned;
	Check the sizing of the power cables;
	If the system uses a switching power supply, replace it with a linear one to avoid electrical disturbances coming from the network.
The system goes into alarm with fog and rain	Check that the fog disqualification function is active (see chap. 12);
	Make sure that the structure is well sealed and check that there are not already elements inside which could create disturbance (water, insects etc.);
	Check the alignment accuracy of each individual optic and, if necessary, carry out the procedure by performing a complete scan, making sure that there are no light sources that can influence the calibration;
	For more precise alignment, position one side of the column cover in front of the lenses in order to have two surfaces interposed between TX and RX to double the attenuation of the beam.
Repeated false alarms	If they are caused by the passage of animals, use the AND functions or increase the intervention time.
	Check the alignment accuracy of each individual optic and, if necessary, carry out the procedure by performing a complete scan, making sure that there are no light sources that can influence the calibration.
	Check the correct sizing of the power cables;
	If possible, increase the intervention time.



20.Product disposal.

All components of this barrier are an integral part of the equipment and must be disposed of together with it.

Just as with installation operations, also at the end of life of these products, the dismantling operations must be carried out by qualified personnel.

These products are made up of various types of materials: some can be recycled and others must be disposed of. Find out about available recycling or disposal systems for this category of products governed by regulations in force in your area.

Warning!- Some parts of the products may contain polluting or dangerous substances which, if dispersed in the environment, could result in harmful effects on the environment itself and on human health.

As indicated by the symbol on the side, it is forbidden to throw these products in domestic waste.

Therefore, carry out "separate collection" for disposal, according to the methods stipulated by the regulations in force in your area or return the products to the seller when purchasing a new equivalent product.

Warning!- Local regulations can impose heavy penalties for incorrect disposal of these products.



Via Adda, 66/68

20882 Bellusco (MB) • Italy

T +39 039.6883019

F +39 039.6200471

assistenza@politecsrl.it

www.politecsrl.it

