



# Ruijie RG-AP680-IO Access Point

## Hardware Installation and Reference Guide

Document Version: V1.3

Date: 2023.11.21

Copyright © 2023 Ruijie

Networks

## Copyright

Copyright © 2023 Ruijie Networks

All rights are reserved in this document and this statement.

Any reproduction, excerpt, backup, modification, transmission, translation or commercial use of this document or any portion of this document, in any form or by any means, without the prior written consent of Ruijie Networks is prohibited.

Trademark  and  are owned by Ruijie Networks.

All other trademarks or registered trademarks mentioned in this document are owned by their respective owners.

## Disclaimer

The products, services, or features you purchase are subject to commercial contracts and terms. Some or all of the products, services or features described in this document may not be within the scope of your purchase or use. Unless otherwise agreed in the contract, Ruijie Networks does not make any express or implied statement or guarantee for the content of this document.

Due to product version upgrades or other reasons, the content of this document will be updated from time to time. Ruijie Networks reserves the right to modify the content of the document without any notice or prompt.

This manual is for reference only. Ruijie Networks endeavors to ensure content accuracy and will not shoulder any responsibility for losses and damages caused due to content omissions, inaccuracies or errors.

# Preface

## Intended Audience

This document is intended for:

- Network engineers
- Technical support and servicing engineers
- Network administrators

## Technical Support

- Ruijie Networks Website: <https://www.ruijienetworks.com/>
- Technical Support Website: <https://ruijienetworks.com/support>
- Case Portal: <https://caseportal.ruijienetworks.com>
- Community: <https://community.ruijienetworks.com>
- Technical Support Email: [service\\_rj@ruijienetworks.com](mailto:service_rj@ruijienetworks.com)
- Live Chat: <https://www.ruijienetworks.com/rita>

## Conventions

### 1. Signs

The signs used in this document are described as follows:

---

#### **Warning**

An alert that calls attention to important rules and information that if not understood or followed can result in data loss or equipment damage.

---

---

#### **Caution**

An alert that calls attention to essential information that if not understood or followed can result in function failure or performance degradation.

---

---

#### **Note**

An alert that contains additional or supplementary information that if not understood or followed will not lead to serious consequences.

---

---

 **Specification**

An alert that contains a description of product or version support.

---

**2. Note**

The manual offers configuration information (including model, port type and command line interface) for indicative purpose only. In case of any discrepancy or inconsistency between the manual and the actual version, the actual version prevails.

# Contents

Preface.....	I
1 Product Introduction.....	1
1.1 Overview .....	1
1.2 Product Appearance .....	2
1.3 Package Contents.....	4
1.4 Technical Specifications .....	5
1.4.1 Dimensions and Weight.....	5
1.4.2 RF Specifications.....	6
1.4.3 Port Specifications.....	7
1.4.4 Power Supply and Consumption .....	8
1.4.5 Environment and Reliability .....	9
1.5 LED and Button.....	10
1.6 Optical Module .....	11
2 Preparing for Installation.....	13
2.1 Safety Precautions.....	13
2.1.1 General Safety Precautions .....	13
2.1.2 Handling Safety .....	13
2.1.3 Electric Safety.....	14
2.1.4 Storage Security .....	14

2.2 Installation Environment Requirements .....	14
2.2.1 Bearing Requirements .....	15
2.2.2 Ventilation Requirements.....	15
2.2.3 Space Requirements .....	15
2.2.4 Temperature/Humidity Requirements.....	15
2.2.5 Grounding Requirements.....	16
2.2.6 Anti-interference Requirements .....	16
2.2.7 Lightning Protection Requirements .....	17
2.2.8 Waterproof Requirements.....	17
2.2.9 Other Requirements .....	18
2.3 Tools .....	19
3 Installation .....	20
3.1 Installation Procedure .....	20
3.2 Before You Begin.....	21
3.3 Precautions .....	21
3.4 Installing the Device.....	22
3.4.1 Installing the Support for Wall-mounted Installation.....	22
3.4.2 Installing the Support for Pole-mounted Installation.....	22
3.4.3 Mounting Bracket and Device Installation.....	23
3.4.4 Removing the Device .....	26
3.5 Installing an Optical Module .....	26

3.6 Connecting Cables .....	27
3.6.1 Connecting the Ground Cable.....	27
3.6.2 Connecting the Network Cable .....	28
3.6.3 Connecting the Fiber-Optic Cable.....	29
3.7 Bundling Cables.....	30
3.7.1 Precautions .....	30
3.7.2 Bundling Description .....	31
3.8 Installation Verification.....	31
3.8.1 Checking the AP.....	31
3.8.2 Checking Cable Connections.....	32
3.8.3 Checking the Power Supply.....	32
4 Verifying Operating Status .....	33
4.1 Establishing the Configuration Environment .....	33
4.2 Powering on the AP.....	33
4.2.1 Checklist Before Power-on .....	33
4.2.2 Checking the Environment After Power-on .....	33
5 Monitoring and Maintenance.....	34
5.1 Monitoring .....	34
5.1.1 LED.....	34
5.1.2 CLI Commands .....	34
5.2 Remote Maintenance.....	34

5.3 Hardware Maintenance .....	34
6 Troubleshooting .....	35
6.1 General Troubleshooting Procedure.....	35
6.2 Common Troubleshooting Procedures.....	35
6.2.1 Ethernet Port Is Not Working After the Ethernet Cable Is Plugged In .....	35
6.2.2 LED Is Off for a Long Time.....	35
6.2.3 LED Is Steady Red .....	36
6.2.4 LED Is Steady Green .....	36
6.2.5 LED Keeps Blinking Blue at an Interval of 0.2s (in Fit Mode).....	36
6.2.6 LED Does Not Turn Steady Blue or Blinking Blue .....	36
6.2.7 No Wireless Signal Searched.....	36
7 Appendix .....	37
7.1 Connectors and Media.....	37
7.2 Cabling Recommendations .....	40
7.3 Optical Modules and Specifications.....	45



# 1 Product Introduction

## 1.1 Overview

The RG-AP680-IO is a Wi-Fi 6, dual-radio, enhanced, and industrial wireless access point (AP) provided by Ruijie Networks for higher education, wireless city, energy, business mall, and other scenarios.

The RG-AP680-IO supports the 802.11ax, 802.11ac Wave2, 802.11ac Wave1, and 802.11n protocols. With hardware-independent quad-band design, the AP can provide up to 5.951 Gbps access rate. The ultra-fast wireless network makes performance no longer a bottleneck.

Important factors such as the wireless network security, radio control, mobile access, Quality of Service (QoS), seamless roaming, and expansion of the Internet of Things (IoT) module are fully taken into account for this product. Therefore, this AP can be used in combination with Ruijie Access Controllers (ACs) and WIS to implement STA data forwarding, security, access control, and IoT application extension.

Thanks to its IP68 rated housing, the RG-AP680-IO is suitable for use in extreme industrial environments and capable of effectively withstanding harsh weather and environments. It is highly adaptable to colder and wet climates, allowing for easier installation and maintenance.

The RG-AP680-IO supports power over Ethernet (PoE) and built-in omnidirectional antennas to meet Wi-Fi network coverage and networking requirements in most environments.

## 1.2 Product Appearance

Figure 1-1 Front View

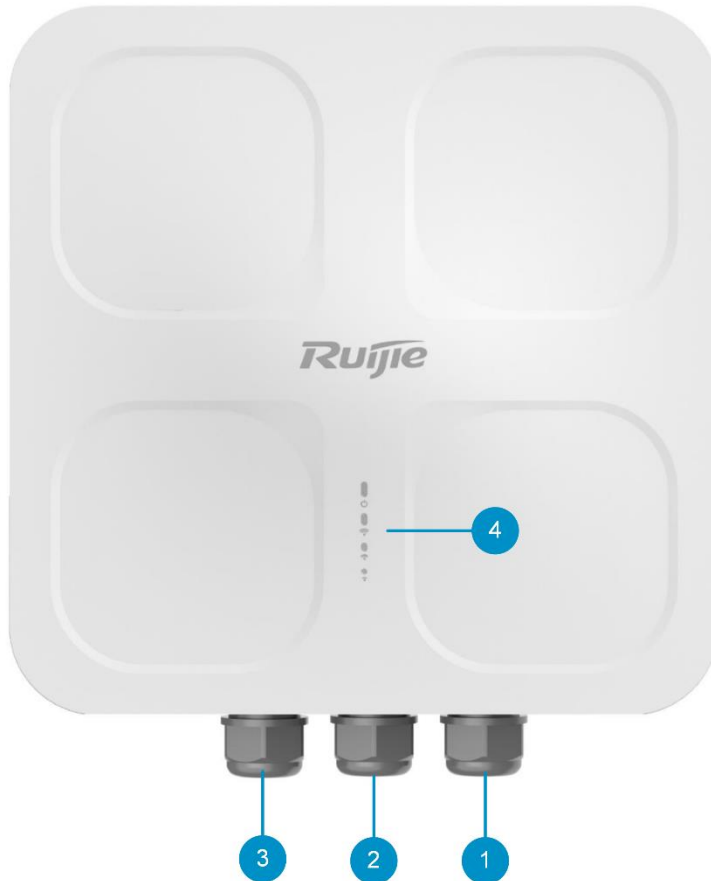
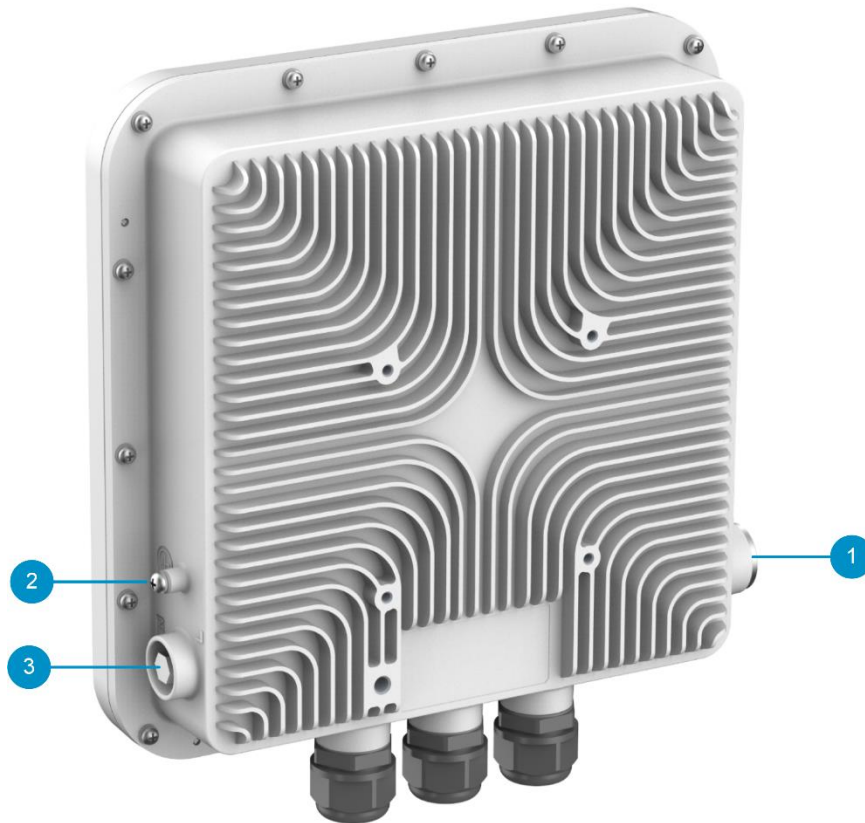


Table 1-1 Description of Buttons and Ports on the Front Panel

No.	Item	Description
1	LAN1/HPoE electrical port	Uplink service port for data transmission, 5000Base-T Ethernet port with auto-negotiation Support IEEE802.3af/802.3at/802.3bt-complaint PoE
2	LAN2/IoT	Downlink service port for data transmission, 1000Base-T Ethernet port with auto-negotiation Support 802.3af-complaint power supply to external devices
3	LAN3/SFP+	Uplink service port for data transmission, 10GE SFP port

No.	Item	Description
4	LED	Used to indicate the system working status, including one system status LED and three RSSI LEDs

**Figure 1-2Rear View**



**Table 1-2 Description of Buttons and Ports on the Rear Panel**

No.	Item	Description
1	Console port/Reset button	<p>The port integrates the functions of a console port and a reset button.</p> <ul style="list-style-type: none"> <li>● The console port is used to connect with a serial cable for device management.</li> <li>● The Reset button is used to restart a device or restore factory settings of the device.</li> </ul>

No.	Item	Description
2	Grounding stud	Used to ground the AP.
3	Breathable valve	Used to balance the pressure difference inside and outside the AP, meeting IP68 rating requirements.

**i Note**

The nameplate is at the bottom of the access point.

## 1.3 Package Contents

**Table 1-3 Package Contents**

No.	Item	Quantity	Remarks
1	AP	1	
2	Mounting bracket	1	
3	Support for pole-mounted or wall-mounted installation	1	
4	M5 x 10 machine screw	4	
5	M6 x 16 machine screw	2	
6	M8 x 20 machine screw	2	
7	M6 x 40 expansion anchor	4	
8	Waterproof PG connector	2	The rubber plug only has one hole and adapts to network cables with a diameter of 6.6 to 8.6 mm.
9	Waterproof connector for the	1	The rubber plug has two holes

No.	Item	Quantity	Remarks
	fiber-optic cable		and adapts to LC-LC fiber-optic cables with a diameter of 2.5 to 3.5 mm.
10	Metal hook	2	Adapts to poles with a diameter of 80 to 140 mm
11	Ground cable	1	
12	Product warranty manual	1	
13	Dust cap for ports	4	The dust caps are pre-installed on the AP.
14	User Manual	1	

## 1.4 Technical Specifications

### 1.4.1 Dimensions and Weight

**Table 1-4 Dimensions and Weight**

Dimensions and Weight	RG-AP680-IO
Dimensions (W × D × H)	300 mm × 300 mm × 94 mm (11.81 in. x 11.81 in. x 3.70 in.)
Weight	Main unit: 3.3 kg (7.28 lbs) Mounting bracket: 1.2 kg (2.65 lbs)
Installation	Wall-mounted or pole-mounted
Mounting bracket Dimensions (W x D x H)	130 mm × 282 mm x 130 mm (5.12 in. x 11.10 in. x 5.12 in.)

<b>Dimensions and Weight</b>	<b>RG-AP680-IO</b>
Mounting hole pattern	105 mm × 65 mm (4.13 in. x 2.56 in.)
Mounting hole diameter	9 mm (0.35 in.)
Pole diameter	80 mm to 140 mm (3.15 in to 5.51 in.)

## 1.4.2 Radio Specifications

**Table 1-5 Radio Specifications**

<b>Radio Specifications</b>	<b>RG-AP680-IO</b>
Radio design	Dual-radio, eight spatial streams Radio 1: 2.4 GHz, 4 spatial streams: 4x4, MIMO Radio 2: 5 GHz, 4 spatial streams: 4x4, MIMO
Operating frequencies	Radio 1: 802.11b/g/n/ax, 2.400 to 2.4835 GHz Radio 2: 802.11a/n/ac/ax, 5.150 GHz to 5.350 GHz, 5.470 GHz to 5.725 GHz, 5.725 to 5.850 GHz Note: The operating frequency is country-specific.
Data rate	Radio 1: 2.4 GHz, 1.147 Gbps Radio 2: 5 GHz, 4.804 Gbps Combined: 2.4 GHz + 5 GHz, 5.951 Gbps
Antenna type	Built-in omnidirectional antennas
Antenna gain	2.4 GHz: 6 dBi 5 GHz: 5 dBi
Max. transmit	30 dBm

Radio Specifications	RG-AP680-IO
power	Note: The transmit power varies based on the regulations in different countries and regions.
Power increment	1 dBm
Modulation	802.11b: BPSK、QPSK、CCK 802.11a/g/n: BPSK、QPSK、16-QAM、64-QAM 802.11ac: BPSK、QPSK、16-QAM、64-QAM、256-QAM 802.11ax: BPSK、QPSK、16-QAM、64-QAM、256-QAM、1024-QAM
Receive sensitivity	802.11b: -96 dBm (1 Mbps), -93 dBm (5 Mbps), -89 dBm (11 Mbps) 802.11a/g: -91 dBm (6 Mbps), -85 dBm (24 Mbps), -80 dBm (36 Mbps), -74 dBm (54 Mbps) 802.11n: -90 dBm (MCS0), -70 dBm (MCS7), -89 dBm (MCS8), -68 dBm (MCS15) 802.11ac: HT20: -88 dBm (MCS0), -63 dBm (MCS9) 802.11ac: HT40: -85 dBm (MCS0), -60 dBm (MCS9) 802.11ac: HT80: -85 dBm (MCS0), -60 dBm (MCS9) 802.11ac: HT160: -80 dBm (MCS0), -55 dBm (MCS9) 802.11ax: HE80: -82 dBm (MCS0), -57 dBm (MCS9), -52 dBm (MCS11) 802.11ax: HE160: -80 dBm (MCS0), -49 dBm (MCS11)

### 1.4.3 Port Specifications

Table 1-6 Port Specifications

Port Specifications	RG-AP680-IO
Bluetooth	Bluetooth 5.1
Fixed service port	Uplink:

	<p>One 100/1000/2500/5000Base-T Ethernet port with auto-negotiation, supporting IEEE 802.3af/at/bt-compliant PoE</p> <p>Two 10 Gbps SFP+ Ethernet optical ports with auto-negotiation, which are compatible with 2.5 Gbps/1 Gbps optical ports</p> <p>Downlink:</p> <p>One 10/100/1000Base-T Ethernet port with auto-negotiation, which allows the PSE to power external devices (802.3af, 15.4 W) and can connect to Ruijie IoT module</p>
Fixed management port	One RJ45 console port
Status LED	<p>One system status LED</p> <p>Three RSSI LEDs</p>
Button	One reset hole
GPS	Supported

## 1.4.4 Power Supply and Consumption

**Table 1-7 Power Supply and Consumption**

Power Supply and Consumption	RG-AP680-IO
Input power supply	<p>PoE/PoE+/PoE++ (IEEE 802.3af/at/bt-compliant)</p> <p>Note: If the AP is powered by 802.3af PoE, only the CPU works. If the AP is powered by 802.3at PoE, Radio 3 does not work and the AP does not supply power to external devices.</p>
External power supply	Supported (Connect to Ruijie IoT module, 802.3af-compliant, support for 15.4 W output power)
Max. power consumption	$\leq 40$ W



**⚠ Caution**

- To power the AP by using PoE, ensure that the device at the other end of the Ethernet cable supports IEEE 802.3af power supply.
- In 802.3af power supply state, the device can be started properly. All RF cards do not work, and the PSE does not power external devices.
- In 802.3at power supply state, the PSE does not power external devices.
- In 802.3bt power supply state, the device has the highest performance and all functions are enabled.
- The AP adopts a fan-free design. Therefore, maintain sufficient clearance around the AP for air circulation.

## 1.4.5 Environment and Reliability

**Table 1-8 Standard Compliance**

<b>Environment and Reliability</b>	<b>RG-AP680-IO</b>
Temperature	Working temperature: -40°C to +65°C (-40°F to +149°F) Storage temperature: -40°C to +85°C (-40°F to +185°F) At a height between 3000 m (9842.52 ft.) and 5000 m (16404.2 ft.), every time the altitude increases by 166 m (546 ft.), the maximum temperature decreases by 1°C (1.8°F).
Humidity	Operating humidity: 0% to 100% RH (non-condensing) Storage humidity: 0% to 100% RH (non-condensing)
IP Rating	IP68
Anti-corrosion rating	GB/T 2423.17
Regulatory compliance	EN 55032, EN 55035, EN 61000-3-3, EN IEC 61000-3-2, EN 301 489-1, EN 301 489-3, EN 301 489-17, EN 300 328, EN 301 893, EN 300 440, FCC Part 15, EN IEC 62311, IEC 62368-1, EN 62368-1, and IEC 60950-22

## 1.5 LED and Button

### Note

The LED description applies to both fit and fat modes unless otherwise specified.

**Table 1-9 LED Status**

Status	Frequency	Description
Off	N/A	The AP is not powered on. The AP is powered on, but the LED is manually turned off.
Steady green	N/A	The software system of the AP is being initialized.
Steady red	N/A	The system is running properly, but the uplink service port is linked down.
Blinking red at an interval of 1s	On for 3s Off for 1s	In fit mode, the setup of a CAPWAP tunnel between the AP and AC timed out.
Blinking blue at an interval of 0.2s	On for 0.2s Off for 0.2s	In fit or MACC mode, the software system of the AP is being updated.
Steady blue	N/A	The system is running properly, but there is no STA online.
Blinking blue at an interval of 1s	On for 1s Off for 1s	The system is running properly and there are one or more STAs online.
Blinking red at an interval of 0.2s	On for 0.2s Off for 0.2s	In fit mode, the AP is being located.

**Table 1-10 Reset button**

Button	Operation	Result
Reset button	Press the button for less than 2s	Reboot the device.
	Press and hold the button for longer than 5s	Restore to factory settings.

**Table 1-11 Bridge LED**

LED Color	No. of Steady-on LED	Description
N/A	N/A	The AP does not enable the bridge function. The AP has enabled the bridge function, but bridging fails.
Green	1	Bridging is successful, and the strength of the wireless signals dedicated for bridging is less than -70 dBm.
Green	1, 2	Bridging is successful, and the strength of the wireless signals dedicated for bridging ranges from -70 dBm to -50 dBm.
Green	1, 2, 3	Bridging is successful, and the strength of the wireless signals dedicated for bridging is greater than -50 dBm.

## 1.6 Optical Module

The type of the port on the device directly connected with the 10G SFP port on the AP can be an optical port or electrical port. However, the negotiated rate varies depending on the port rate or optical module used on both devices. For details, see Table 1-11 and Table 1-12.

**Table 1-12 Rate Negotiation for an Optical Port on the Peer Device**

Optical Port Rate of the AP	Optical Module Rate	Negotiated Rate Supported by the Port on the Peer Device		
		1 Gbps	1 Gbps/10 Gbps/Auto	1 Gbps/2.5 Gbps/10 Gbps/Auto
10 Gbps	10 Gbps	1 Gbps	10 Gbps	10 Gbps
10 Gbps	2.5 Gbps	Not supported	Not supported	2.5 Gbps
10 Gbps	1 Gbps	1 Gbps	1 Gbps	1 Gbps

**Table 1-13 Rate Negotiation for an Electrical Port on the Peer Device**

Optical Port Rate of the AP	O/E Conversion Module Rate	Negotiated Rate Supported by the Port on the Peer Device		
		1 Gbps	1 Gbps/10 Gbps/Auto	1 Gbps/2.5 Gbps/10 Gbps/Auto
10 Gbps	10 Gbps	1 Gbps	10 Gbps	10 Gbps
10 Gbps	1 Gbps	1 Gbps	1 Gbps	1 Gbps

# 2 Preparing for Installation

## 2.1 Safety Precautions

---

**Note**

- To avoid personal injury and device damage, carefully read the safety precautions before you install the device.
  - The following safety precautions may not cover all possible dangers.
- 

### 2.1.1 General Safety Precautions

- Do not expose the AP to high temperature, dusts, or harmful gases. Do not install the AP in an inflammable or explosive environment. Keep the AP away from EMI sources such as large radar stations, radio stations, and substations. Do not subject the AP to unstable voltage, vibration, and noises.
- The installation site should be free from water flooding, seepage, dripping, or condensation. The installation site should be selected according to network planning, communications equipment features, and considerations such as climate, hydrology, geology, earthquake, electrical power, and transportation.
- The installation site should be dry. It is not recommended that the AP be installed in a place near the sea. Keep the device at least 500 meters away from the ocean and do not face it towards the sea breeze.
- Do not place the device in walking areas.
- During the installation and maintenance, do not wear loose clothes, ornaments, or any other things that may be hooked by the chassis.
- Keep tools and components away from walking areas.

### 2.1.2 Handling Safety

- Prevent the AP from being frequently handled.
- Cut off all the power supplies and unplug all power cords before moving or handling the device.

---

### 2.1.3 Electric Safety

---

 **Warning**

- Improper or incorrect electric operations may cause a fire, electric shock, and other accidents, and lead to severe and fatal personal injury and device damage.
  - Direct or indirect contact with high voltage or mains power supply via wet objects may cause fatal dangers.
- 

- Observe local regulations and specifications during electric operations. Only personnel with relevant qualifications can perform such operations.
- Check whether there are potential risks in the work area. For example, check whether the ground is wet.
- Find the position of the indoor emergency power switch before installation. Cut off the power switch in case of accidents.
- Check the AP carefully for confirmation before shutting down the power supply.
- Do not place the device in a damp/wet location. Do not let any liquid enter the chassis.
- Keep the AP far away from grounding or lightning protection devices for power equipment.
- Keep the AP away from radio stations, radar stations, high-frequency high-current devices, and microwave ovens.

### 2.1.4 Storage Security

For proper working of the AP, the AP must be stored in an environment based on the storage temperature/humidity requirements in Specifications.

---

 **Caution**

If the AP is stored for more than 18 months, power on the AP and run it for consecutive 24 hours to activate the AP.

---

## 2.2 Installation Environment Requirements

The installation site must meet the following requirements.

## 2.2.1 Bearing Requirements

Evaluate the weight of the device and its accessories (such as the bracket and power supply module), and ensure that the ground of the installation site meets the requirements.

## 2.2.2 Ventilation Requirements

Reserve sufficient space in front of the air vents to ensure normal heat dissipation. After various cables are connected, bundle the cables or place them in the cable management bracket to avoid blocking air inlets.

## 2.2.3 Space Requirements

Maintain a minimum clearance of 0.4 m around the device to ensure proper cooling and ventilation.

## 2.2.4 Temperature/Humidity Requirements

To ensure the normal operation and a prolonged service life of the AP, maintain an appropriate temperature and humidity in the installation environment.

The installation environment with too high or too low temperature and humidity for a long period of time may damage the AP.

- In an environment with high relative humidity, the insulating material may have bad insulation or even leak electricity.
- In an environment with low relative humidity, the insulating strip may dry and shrink, loosening screws.
- In a dry environment, static electricity is prone to occur and damage the internal circuits of the AP.
- Too high temperatures can accelerate the aging of insulation materials, greatly reducing the reliability of the AP and severely affecting its service life.

---

### Note

The ambient temperature and humidity of the device are measured at the point that is 1.5 m (59.06 in.) above the floor and 0.4 m (15.75 in.) before the device when there is no protective plate in front or at the back of the device.

---

## 2.2.5 Grounding Requirements

A good grounding system is the basis for stable and reliable operation of the device, preventing lightning strokes and resisting interference. Carefully check the grounding conditions at the installation site according to the grounding requirements, and perform grounding operations properly as required.

- Safety Grounding

The device using AC power supply must be grounded by using the yellow/green safety grounding cable. Otherwise, an electric shock may occur when the insulation resistance between the power supply and the device enclosure decreases.

---

### Caution

The building must provide the protective grounding connection to ensure that the device is connected to the protection location.

---

### Lightning Grounding

The lightning protection system of a facility is an independent system that consists of the lightning rod, down conductor, and connector to the grounding system, which usually shares the power reference ground and ground cable. The lightning discharge ground is targeted for the facility.

### EMC Grounding

The grounding required for EMC design includes the shielding ground, filter ground, noise and interference suppression, and level reference. All the above constitute the comprehensive grounding requirements. The resistance of earth wires should be less than 1  $\Omega$ . The cabinet should be grounded according to the requirements before the device works.

## 2.2.6 Anti-interference Requirements

- Take interference prevention measures for the power supply system.
- Keep the AP away from the grounding equipment or lightning and grounding equipment of the power device as much as possible.
- Keep the AP far away from high-frequency current devices such as the high-power radio transmitting station and radar launcher.
- Take electromagnetic shielding measures when necessary.



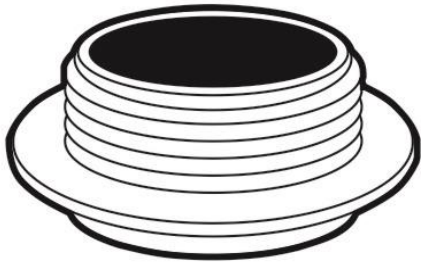
## 2.2.7 Lightning Protection Requirements

The RG-AP680-IO can guard against lightning strikes. As an electric device, too strong lightning strikes may still damage the device. Take the following lightning protection measures:

- Ensure that the neutral point of the AC power socket is in good contact with the ground.
- It is recommended that you install a power lightning arrester in front of the power input end to enhance the lightning prevention for the power supply.
- Keep the grounding connection within 30 m, and use a 40 mm x 4 mm or 50 mm x 5 mm ground bar of hot-dip zinc-coated flat steel sheet.
- When the connection cable between the main grounding conductor and local equipotential earthing terminal board (LEB) on each floor is short, use a stranded copper wire with a sectional area not less than 1.318 mm<sup>2</sup> (16 AWG) for the connection cable.
- Use a shielded network cable if possible, ensure that devices connected to both ends of the shielded network cable are reliably grounded, and make sure that the sheath of the shielded network cable is also grounded if possible. If no shielded network cable is available, wire the network cable through a steel pipe and bury the steel pipe for lead-in, and properly ground both ends of the steel pipe.
- Use a power cable with the PE end to ground the power supply (AC). Ensure that the PE end is properly grounded, with a ground resistance less than 5 ohms. Do not use a two-wire power cable with only the live (L) wire and neutral (N) wire. Do not connect the N wire to the protection ground cable of other communication devices, and ensure that the L wire and N wire are properly connected.
- Ensure that the ground resistance is less than 5 ohms. In areas with high soil resistivity, reduce the soil resistivity via measures such as spreading resistivity reduction mixture around the grounding conductor.

## 2.2.8 Waterproof Requirements

Cap unused ports to ensure waterproof.

**Figure 2-1 Dust Cap**

Connect the network cable, fiber-optic jumper, and AC power cable to the AP after they pass through the corresponding waterproof plugs to ensure waterproof.

## 2.2.9 Other Requirements

Regardless of whether the device is installed on the wall or pole, the following conditions must be met:

- Sufficient space is reserved at the air inlet and air vents of the device, to facilitate heat dissipation of the device.
- The installation site allows for proper cooling and ventilation.
- The installation side is sturdy enough to support the weight of the device and its accessories.
- The device is properly grounded.

## 2.3 Tools

**Table 2-1 Tools**

<b>Common Tools</b>	Marker, Phillips screwdriver, flathead screwdriver, hammer drill, segmented blade utility knife, network cable tester, related power cables and optical cables, adjustable wrench, hammer, binding strap, waterproof tape and cement
<b>Special Tools</b>	ESD tools, crimping pliers, diagonal pliers, network cable pliers, and wire stripper
<b>Meter</b>	Multimeter
<b>Relevant Devices</b>	PC, display, and keyboard

---

** Note**

The RG-AP680-IO is not delivered with a tool kit. The tool kit is customer-supplied.

---

# 3 Installation

The RG-AP680-IO must be installed at a fixed position.

---

**⚠ Caution**

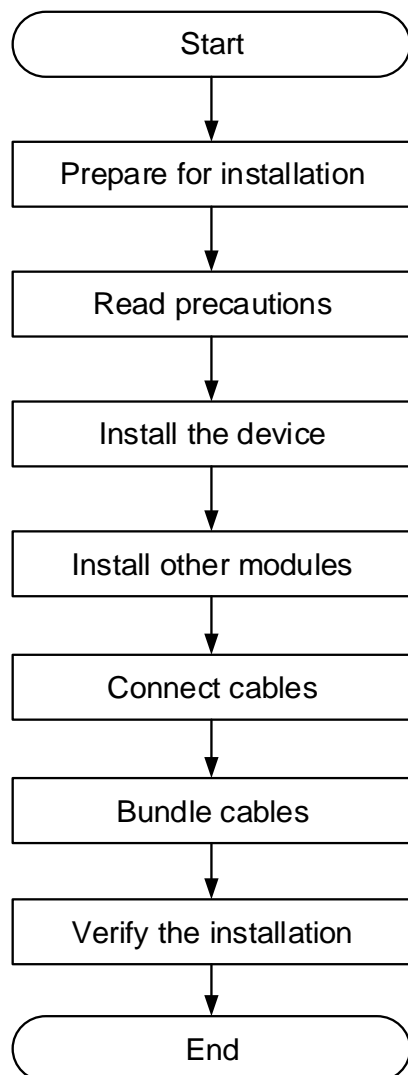
Before installing the device, make sure that you have carefully read the requirements described in Chapter 2.

---

## 3.1 Installation Procedure

The installation steps are shown in the following figure.

**Figure 3-1 Installation Procedure**



## 3.2 Before You Begin

Carefully plan and arrange the installation location, networking mode, power supply, and cabling before installing the device.

Confirm the following requirements before installation:

- The installation location provides sufficient space for heat dissipation.
- The installation location meets the temperature and humidity requirements of the device.
- The power supply and required current are available in the installation location.
- The Ethernet cables have been deployed in the installation location.
- The selected power supply meets the system power requirements.
- The position of the emergency power switch is found before installation, so that the power switch can be cut off in case of accidents.
- For wall-mounted APs, the mounting bracket dimensions, mounting hole pattern, and mounting hole diameter meet the specification requirements in [Table 1-4 Dimensions and Weight](#).
- The diameter range of the pole to which the device is to be mounted meets the specification requirements in [Table 1-4 Dimensions and Weight](#).

## 3.3 Precautions

To ensure the normal operation and prolonged service life of the AP, observe the following safety precautions:

- Do not power on the device during installation.
- Place the device in a well-ventilated environment.
- Do not subject the device to high temperatures.
- Keep the device away from high-voltage power cables.
- Do not expose the device in a thunderstorm or strong electric field.
- Keep the device clean and dust-free.
- Cut off the power switch before cleaning the device.

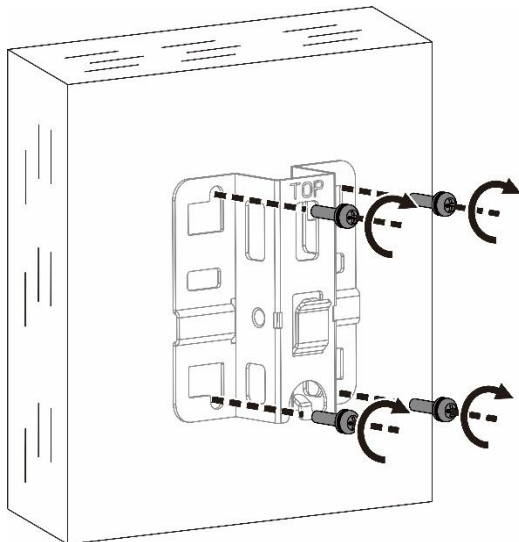
- Do not wipe the device with a damp cloth.
- Do not wash the device with liquid.
- Do not open the enclosure when the device is working.
- Fasten the device tightly.

## 3.4 Installing the Device

### 3.4.1 Installing the Support for Wall-mounted Installation

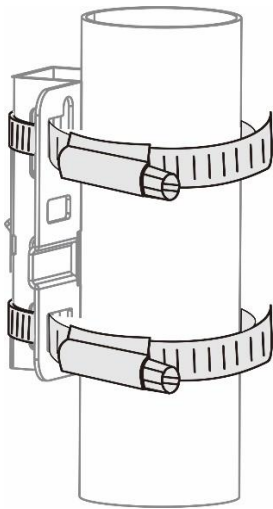
Use four M6 expansion screws (hole of 105 mm x 65 mm or 4.13 in. x 2.56 in.) to fix the support on the wall with the TOP label facing up.

**Figure 3-2** Installing the Support for Wall-mounted Installation



### 3.4.2 Installing the Support for Pole-mounted Installation

Pass two hooks through the opening groove of the support and install them on the pole with the TOP label facing up.

**Figure 3-3 Installing the Support for Pole-mounted Installation**

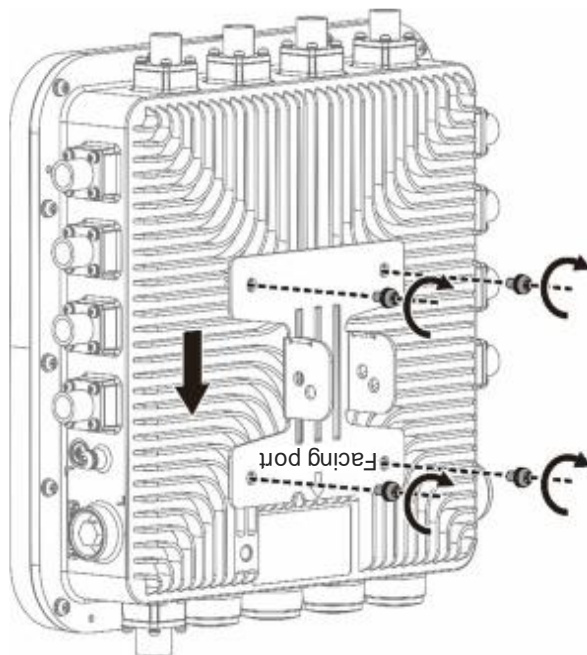
---

**⚠ Caution**

- Use matching screws for the screw holes, and tighten the structural parts in different installation links.
  - Tighten all fastening screws. If any screw is not installed, the device may vibrate violently, shift, or fall down.
  - After installation, check that all screws are tightened to prevent the device from falling down.
- 

### 3.4.3 Mounting Bracket and Device Installation

- (1) Use four M5 combined screws (hole of 100 mm x 100 mm or 3.94 in. x 3.94 in.) to fix the mounting bracket base on the back of the chassis based on the "Facing port" text and arrow indication.

**Figure 3-4** Installing the Mounting Bracket

- (2) Assemble the mounting bracket flange and installation pole and use two M6 hex socket combined screws to fix the left and right sides.

---

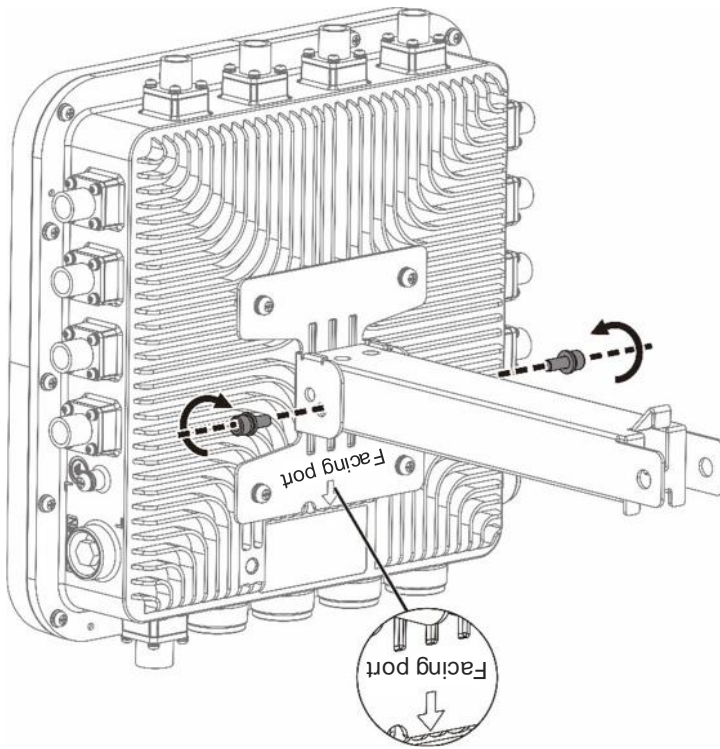
**Note**

The mounting bracket flange and installation pole can be assembled in vertical or horizontal mode based on the actual coverage requirements.

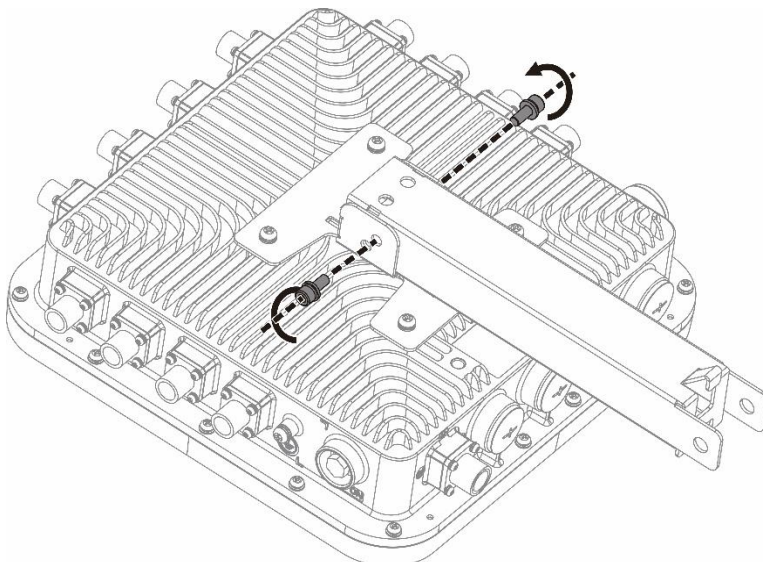
---



**Figure 3-5 Connecting the Mounting Bracket and Installation Pole Based on the Wall-mounted Direction**

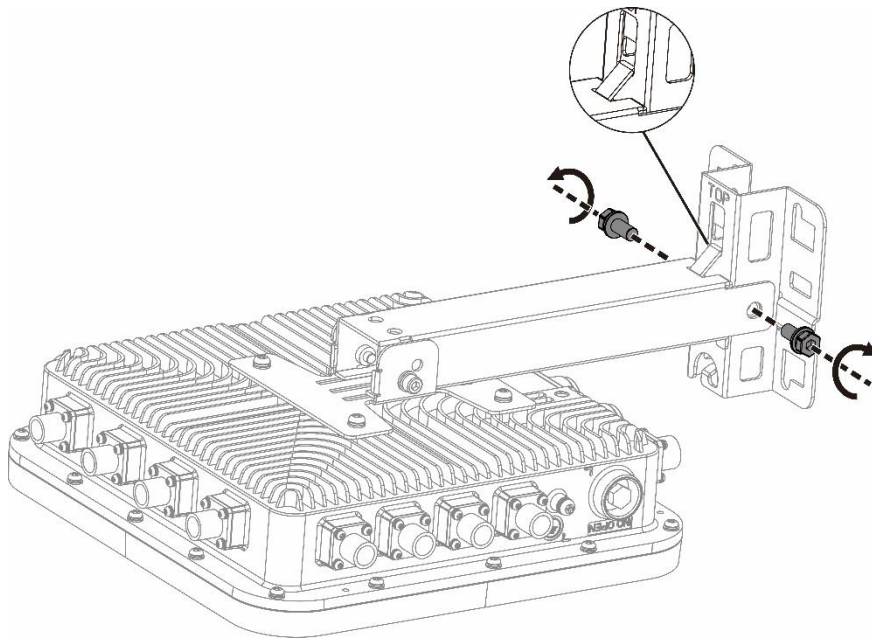


**Figure 3-6 Connecting the Mounting Bracket and Installation Pole Based on the Ceiling-mounted Direction**



- (3) Mount the device with the installation pole installed to the fixed support. Use hooks on the installation pole to connect with the support, and tighten a M8 combined screw on the left and right sides.

**Figure 3-7** Connecting with the Support

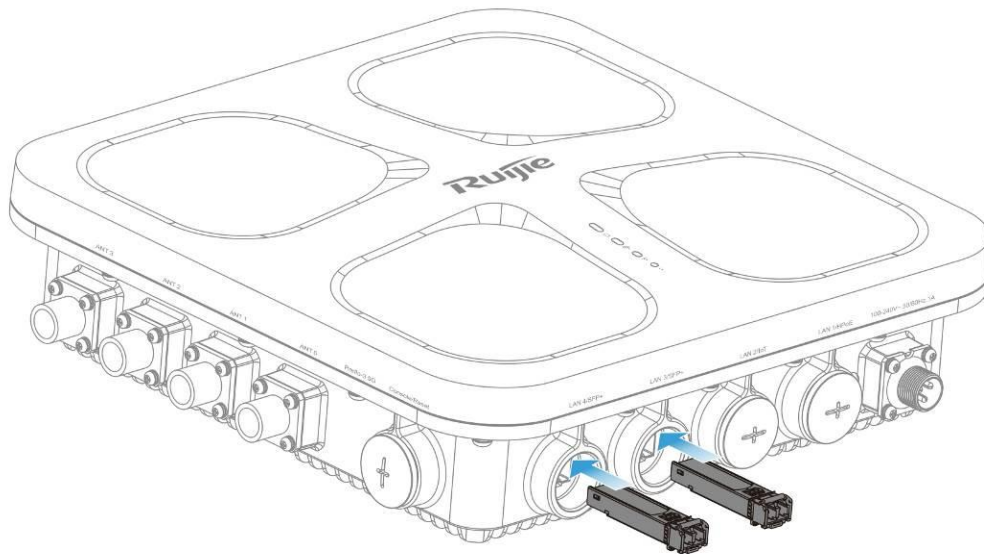


### 3.4.4 Removing the Device

Remove the AP according to the installation steps in reverse sequence.

## 3.5 Installing an Optical Module

Insert the selected optical module into the optical port on the device and ensure that the optical module is properly installed.

**Figure 3-8** Installing an Optical Module

## 3.6 Connecting Cables

---

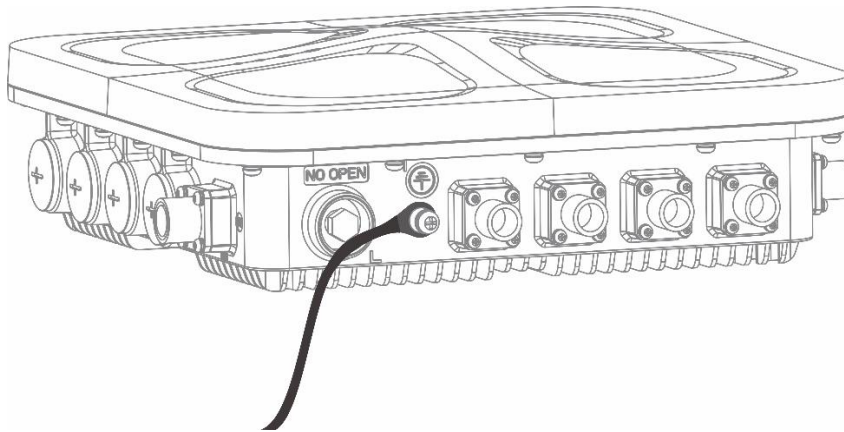
### **Note**

You need to prepare waterproof materials yourself.

---

### 3.6.1 Connecting the Ground Cable

The ground cable needs to be made on site. Connect one end of the yellow/green ground cable delivered with the device to the ground hole of the device through an OT terminal and the other end to the ground through another OT terminal. The cable length can be trimmed based on the on-site situation to avoid waste.

**Figure 3-9 Connecting the Ground Cable**

### 3.6.2 Connecting the Network Cable

---

**⚠ Caution**

- Ensure that the crystal connector of the network cable is properly inserted into the AP. If not, the crystal connector may be damaged when waterproof PG connector is installed.
  - When removing the network cable, remove the waterproof PG connector and then the crystal connector connected with the AP.
  - Use a shielded network cable and ensure that the diameter of the network cable is within the range of 6.6 mm to 8.6 mm.
  - It is recommended that the network cable for power supply to external devices do not exceed 15 m and the voltage at the PoE end is greater than 48 V. Alternatively, adopt AC power supply.
- 

- (1) Based on the distance from the AP to the power supply terminal, cut the network cable to a proper length and pass it through the support.
- (2) Pass the network cable with a crystal connector through the waterproof PG connector based on the sequence shown in the following figure.

**Figure 3-10** Passing the Network Cable Through the Waterproof PG Connector

- (3) Insert the crystal connector of the network cable into the network port on the AP and tighten the waterproof PG connector based on the sequence of parts B, C, D, and E. The network cable is installed.
- (4) Paint waterproof cement and wrap waterproof tapes on the PC connector to ensure waterproof.

### 3.6.3 Connecting the Fiber-Optic Cable

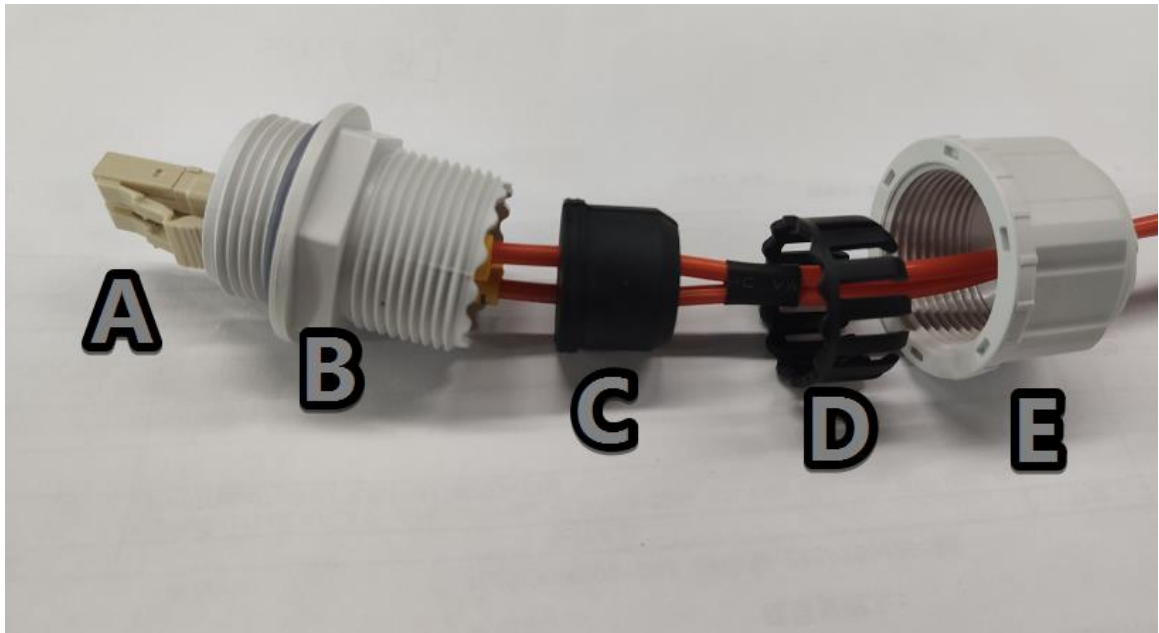
---

**⚠ Caution**

The diameter of the actually used LC-LC fiber-optic cable must be within the range of 2.5 mm to 3.5 mm. A too thick or too thin cable cannot ensure the waterproof performance.

---

- (1) Select an LC-LC fiber-optic cable whose diameter is  $2.7 \pm 0.2$  mm and pass the fiber-optic cable through the waterproof connector based on the sequence shown in the following figure.

**Figure 3-11 Passing the Fiber-Optic Cable Through the Waterproof Connector**

- (2) Insert the optical module into the optical port of the device, and insert the fiber-optic cable into the optical module connector.
- (3) Tighten part B of the waterproof connector on the device, combine parts C and D and place them into B, and tighten part E.
- (4) After the waterproof connector is installed, paint waterproof cement and wrap waterproof tapes on the connector.

---

**⚠ Caution**

When removing the fiber-optic cable, first remove the waterproof connector based on the sequence reversely to the waterproof connector installation sequence. That is, remove the screw cap (E), rubber plug (C), claw (D), and then the main body (B) of the waterproof connector connected with the AP. Otherwise, the cable may be damaged.

---

## 3.7 Bundling Cables

### 3.7.1 Precautions

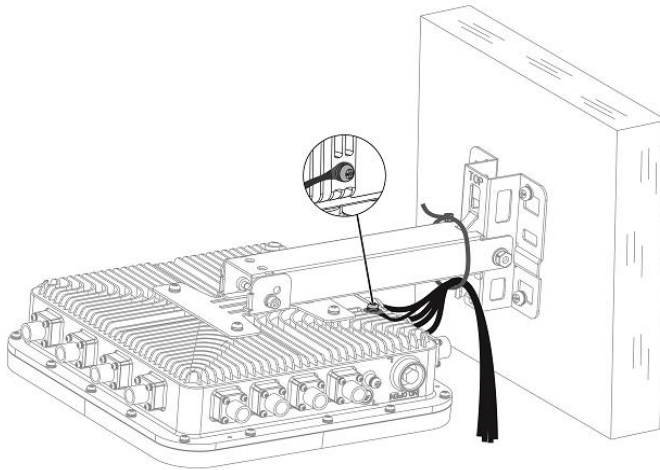
- Bundle cables neatly to ensure aesthetics.
- Bend twisted pairs naturally or to a large radius close to the connector.
- Do not over tighten twisted pair bundle as it may reduce the cable life and

performance.

### 3.7.2 Bundling Description

After the cables are connected with the device through the waterproof plugs and power-on is normal, use a cable tie to bundle the cables on the support and then fix the cables neatly.

**Figure 3-12 Bundling the Cables on the Support Using a Cable Tie**



---

**⚠ Caution**

- After the cables are bundled, check whether waterproof measures are taken properly.
  - The circle in the preceding figure shows the fastening rope installation. Use a M8 screw to lock one end of the fastening rope on the back of the device and lock the other end of the fastening rope in a safe position.
- 

## 3.8 Installation Verification

### 3.8.1 Checking the AP

- Verify that the external power supply matches with the AP.
- Verify that the AP is securely fastened.

### **3.8.2 Checking Cable Connections**

- Verify that the twisted pair cable matches the port.
- Verify that cables are properly bundled.

### **3.8.3 Checking the Power Supply**

- Verify that the power cord is properly connected and compliant with safety requirements.
- Turn on the power supply to supply power to the AP. Verify that the AP works properly.



# 4 Verifying Operating Status

## 4.1 Establishing the Configuration Environment

Power on the AP through PoE.

When setting up the environment, pay attention to the following:

- Verify that the AP is properly connected to the power source.
- Connect the AP to an AC through a twisted pair cable.
- When the AP is connected with a PC, verify that the PC and PoE switch are properly grounded.

## 4.2 Powering on the AP

### 4.2.1 Checklist Before Power-on

- Check whether the power cord is properly connected.
- Check whether the power supply voltage is the same as that required by the AP.

### 4.2.2 Checking the Environment After Power-on

After power-on, you are advised to check the following to ensure the normal operation of the AP:

- Check if any message is printed on the configuration interface of the device.
- Check whether the LEDs are normal.

# 5 Monitoring and Maintenance

## 5.1 Monitoring

### 5.1.1 LED

You can observe the LEDs to monitor the device in operation.

### 5.1.2 CLI Commands

You can run related commands on the CLI of the device to remotely monitor the device, including:

- Port configuration and status
- System logs

---

**Note**

- For details about the commands, see the corresponding configuration guide.
  - The AP supports remote maintenance.
- 

## 5.2 Remote Maintenance

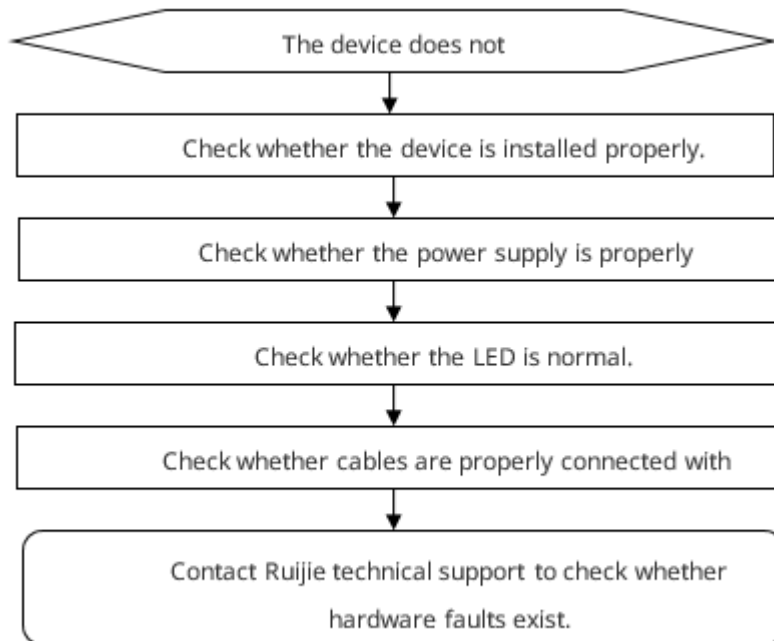
- If the AP works in fat mode, you can log in to the AP remotely for maintenance.
- If the AP works in fit mode, you can use an AC to centrally manage and maintain the AP.

## 5.3 Hardware Maintenance

If the hardware is faulty, please contact Ruijie technical support.

# 6 Troubleshooting

## 6.1 General Troubleshooting Procedure



## 6.2 Common Troubleshooting Procedures

### 6.2.1 Ethernet Port Is Not Working After the Ethernet Cable Is Plugged In

Verify that the device at the other end of the Ethernet cable is working properly. And then verify that the Ethernet cable is capable of providing the required data rate and is properly connected.

### 6.2.2 LED Is Off for a Long Time

- If you use a PoE power supply, verify that the power source is IEEE 802.11af-compliant, and then verify that the cable is connected properly.

### 6.2.3 LED Is Steady Red

The LED keeps steady red for a long time, indicating that the Ethernet port is not connected. Verify the Ethernet connection.

### 6.2.4 LED Is Steady Green

The device performs initialization after power-on. During this period, the LED keeps steady green and does not turn normal blue until the initialization is completed. Note: If the steady green persists for an hour, the device initialization fails and the device is faulty.

### 6.2.5 LED Keeps Blinking Blue at an Interval of 0.2s (in Fit Mode)

Sometimes the AP performs software upgrade after power-on. During this period, the LED keeps blinking blue at an interval of 0.2s and does not turn steady blue until the upgrade is completed. Note: Do not plug or unplug the power cord when the LED is blinking as software upgrade takes time. If the blinking persists for 10 minutes, the device fails to complete software upgrade and is faulty.

### 6.2.6 LED Does Not Turn Steady Blue or Blinking Blue

If the LED does not turn steady blue or blinking blue after the system starts, the AP probably has not established a proper CAPWAP connection with the AC. Verify that the AC is operational and configured properly.

### 6.2.7 No Wireless Signal Searched

- (1) Verify that the device is properly powered.
- (2) Verify that the Ethernet port is correctly connected.
- (3) Verify that the AP is correctly configured.
- (4) Move the client device to adjust the distance between the client and the AP.

# 7 Appendix

## 7.1 Connectors and Media

- 5000BASE-T/2500BASE-T/1000BASE-T/100BASE-TX/10BASE-T port

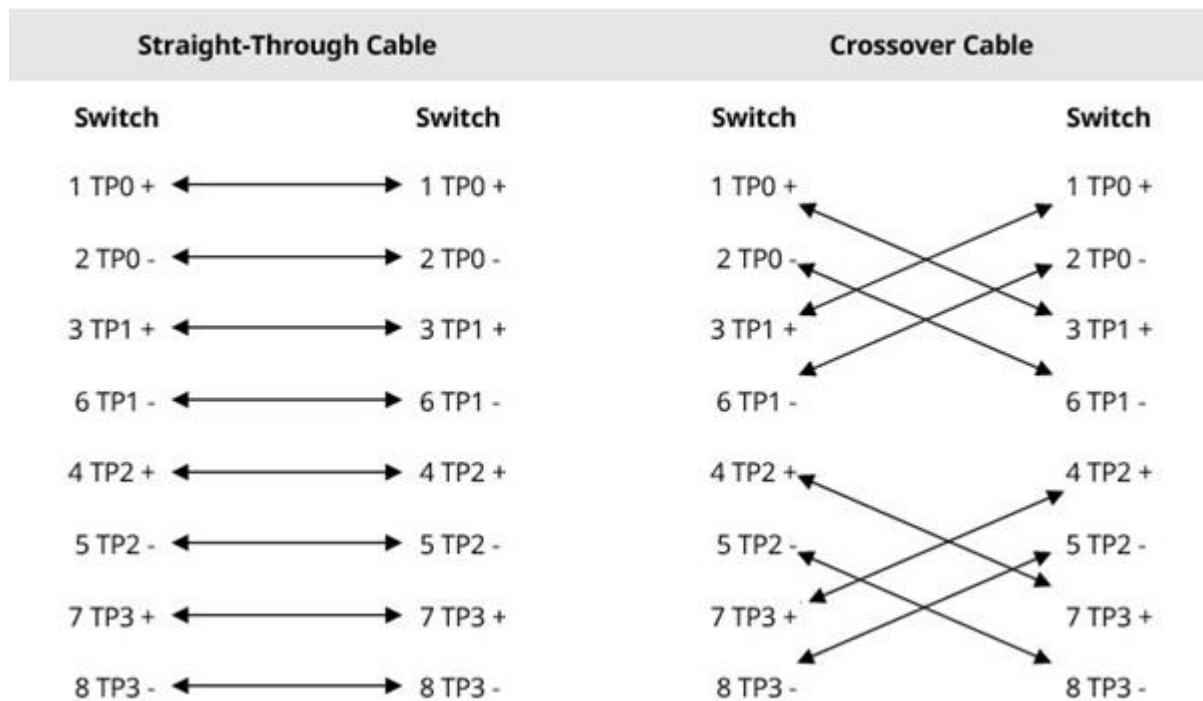
The 5000BASE-T/2500BASE-T/1000BASE-T/100BASE-TX/10BASE-T port supports auto-negotiation of five rates and supports auto MDI/MDIX crossover at these five rates.

Compliant with IEEE 802.3bz, the 5000BASE-T/2500BASE-T port requires at least Category 6 STP with a maximum distance of 100 m (328.10 ft). Category 6, 6A, and 7 STPs are recommended.

Compliant with IEEE 802.3ab, the 1000BASE-T port requires 100-ohm Category 5/5e UTP or STP with a maximum distance of 100 m (328.10 ft).

The 1000BASE-T port requires all four pairs of wires be connected for data transmission. Table 7-1 shows the four pairs of wires for the 1000BASE-T port.

**Table 7-1 1000BASE-T Twisted Pair Connections**



In addition to the preceding cables, the 100BASE-TX/10BASE-T can also use 100-ohm Category-3, Category-4, and Category-5 cables for 10 Mbps, and 100-ohm Category-5

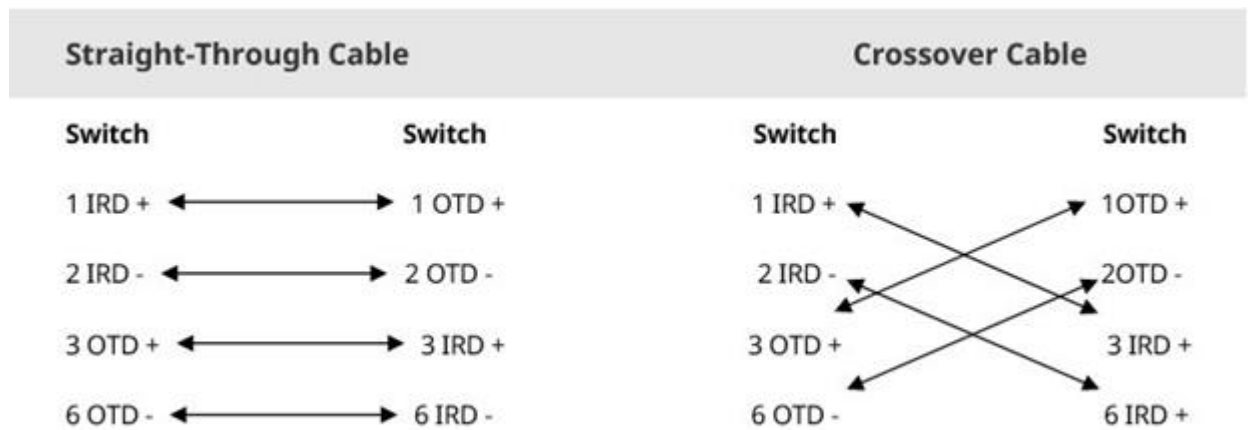
cables for 100 Mbps, both of which can be up to 100 m (328.10 ft). Table 7-2 shows the pinouts of the 100BASE-TX/10BASE-T.

**Table 7-2 Pinouts of the 100BASE-TX/10BASE-T**

Pin	Socket	Plug
1	Input Receive Data+	Output Transmit Data+
2	Input Receive Data-	Output Transmit Data-
3	Output Transmit Data+	Input Receive Data+
6	Output Transmit Data-	Input Receive Data-
4, 5, 7, 8	Not Used	Not Used

Table 7-3 shows the straight-through and crossover cable connections for the 100BASE-TX/10BASE-T.

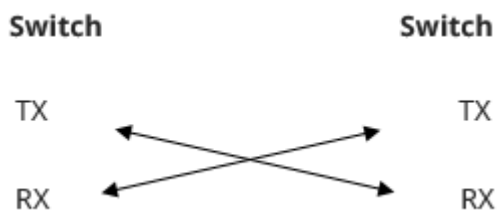
**Table 7-3 100BASE-TX/10BASE-T Twisted Pair Connections**



- Fiber-Optic Cable Connection

For the optical ports, select single-mode or multimode fiber-optic cables for connections according to the optical module connected. Table 7-4 shows the connection schematic diagram.

**Table 7-4 Fiber-Optic Cable Connections**

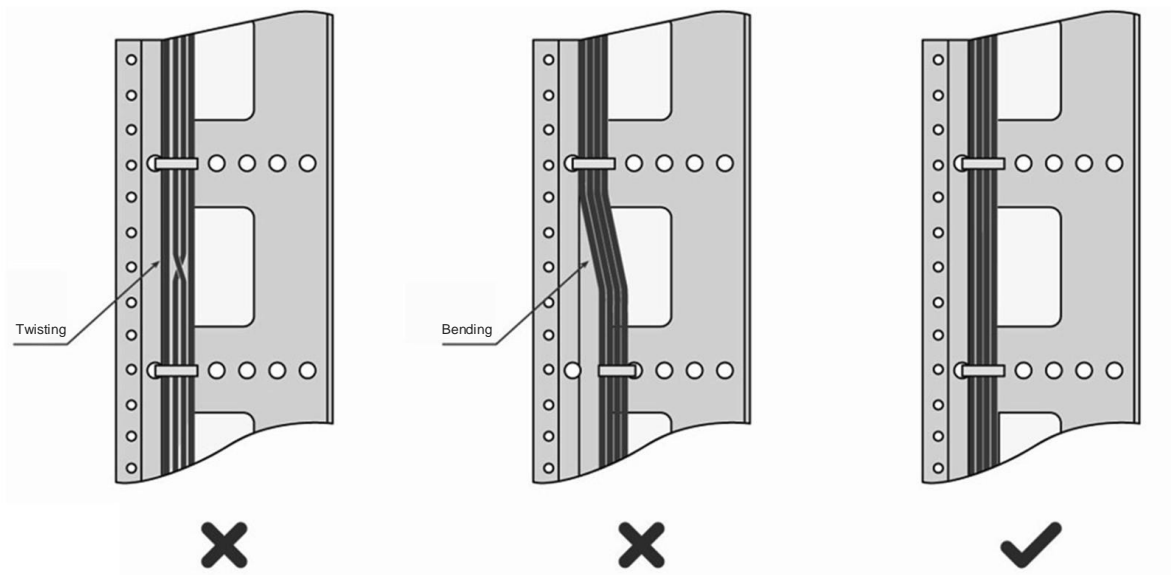


## 7.2 Cabling Recommendations

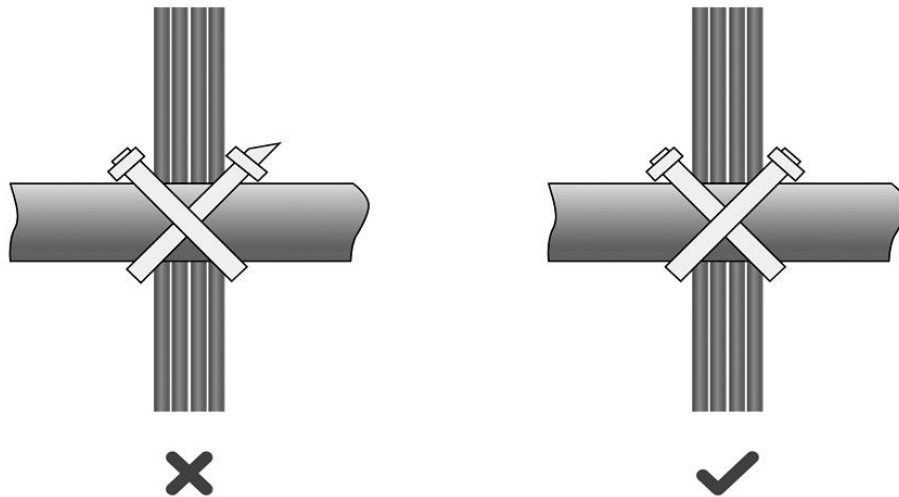
During installation, route cable bundles upward or downward along the sides of the rack depending on the actual situation in the equipment room. All cable connectors should be placed at the bottom of the cabinet rather than be exposed outside of the cabinet. Power cords are routed beside the cabinet, and top cabling or bottom cabling is adopted according to the actual situation in the equipment room, such as the positions of the DC power distribution box, AC socket, or lightning protection box.

- Requirement for the Minimum Cable Bend Radius
  - The bend radius of a power cable, communication cable, or flat cable should be over five times greater than their respective diameters. The bend radius of these cables that is often bent or plugged or unplugged should be over seven times greater than their respective diameters.
  - The bend radius of a fixed common coaxial cable should be over seven times greater than its diameter. The bend radius of the common coaxial cable that is often bent or plugged should be over 10 times greater than its diameter.
  - The minimum bend radius of a high-speed cable, such as an SFP+ cable should be over five times the overall diameter of the cable. If the cable is frequently bent, plugged or unplugged, the bend radius should be over 10 times the overall diameter.
- Precautions for Cable Bundling
  - Before cables are bundled, mark labels and stick the labels to cables wherever appropriate.
  - Cables should be neatly and properly bundled in the cabinet without twisting or bending, as shown in [Figure 7-1](#).

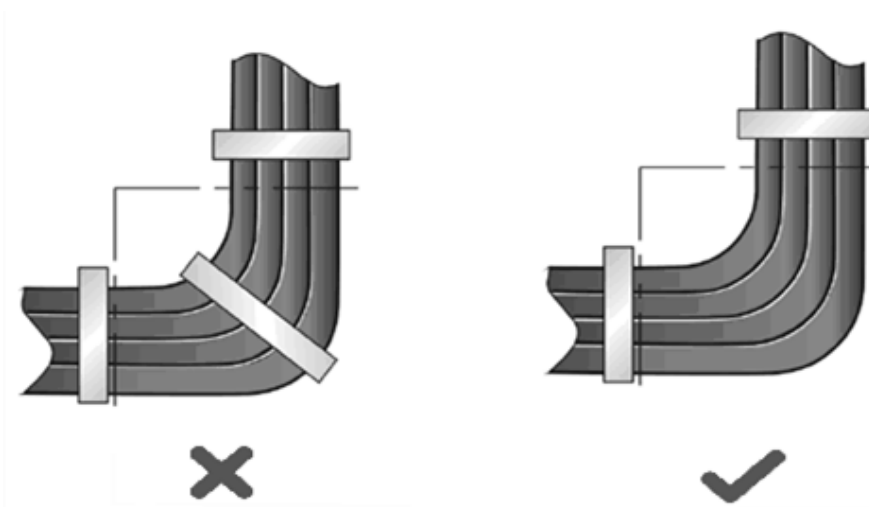


**Figure 7-1 Bundling Cables**

- Cables of different types (such as power cables, signal cables, and ground cables) should be separated in cabling and bundling. Mixed bundling is not allowed. When they are close to each other, it is recommended that crossover cabling be adopted. In the case of parallel cabling, maintain a minimum distance of 30 mm between power cords and signal cables.
- The cable management brackets and cabling troughs inside and outside the cabinet should be smooth without sharp corners.
- The metal hole traversed by cables should have a smooth and fully rounding surface or an insulated lining.
- Proper cable ties should be selected to bundle up cables. It is forbidden to connect two or more cable ties to bundle up cables.
- After bundling up cables with cable ties, cut off the remaining part. The cut should be smooth and trim, without sharp corners, as shown in [Figure 7-2](#).

**Figure 7-2 Cutting off Excess Cable Tie**

- When cables need to be bent, bind them first but do not tie cable ties within the bend. Otherwise, considerable stress may be generated in cables, breaking cable cores, as shown in [Figure 7-3](#).

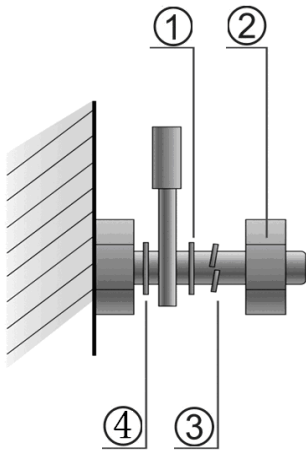
**Figure 7-3 Binding Cables**

- Cables not to be assembled or remaining parts of cables should be folded and placed in a proper position of the cabinet or cable trough. The proper position indicates a position that will not affect device running or cause device damage or cable damage during debugging.
- 220 V and -48 V power cables must not be bundled on the guide rails of moving parts.
- The power cables connecting moving parts such as door grounding wires should be reserved with some access after being assembled to avoid suffering tension or stress. When a moving part reaches the installation position, the remaining cable

part should not touch heat sources, sharp corners, or sharp edges. If heat sources cannot be avoided, high-temperature cables should be used.

- When screw threads are used to fasten cable terminals, the bolt or screw must be tightly fastened, and anti-loosening measures should be taken, as shown in [Figure 7-4](#).

**Figure 7-4 Fastening Cable Lugs**



- |               |                 |
|---------------|-----------------|
| ① Flat washer | ③ Spring washer |
| ② Nut         | ④ Flat washer   |

- Hard power cords should be fastened in the terminal connection area to prevent stress on terminal connection and cable.
- Do not use self-tapping screws to fasten terminals.
- Power cables of the same type and in the same cabling direction should be bundled up into cable bunches, with cables in cable bunches clean and straight.
- Bundle up cables using cable ties based on the following table.

Cable Bunch Diameter (mm)	Distance Between Every Binding Point (mm)
10	80-150
10-30	150-200
30	200-300

- No knot is allowed in cabling or bundling.
- For wiring terminal blocks (such as circuit breakers) with cord end terminals, the metal part of the cord end terminal should not be exposed outside the terminal block when assembled.

## 7.3 Optical Modules and Specifications

We provide appropriate optical modules according to the port types. You can select the module to suit your specific needs. The following tables list the models and technical specifications of some optical modules for reference.

**Table 7-5 Models and Technical Specifications of SFP Modules**

Wavelength (nm)	Fiber Type	DDM	Intensity of Transmitted Light (dBm)		Intensity of Received Light (dBm)	
			Min.	Max.	Min.	Max.
850 Tx/850 Rx	Multimode	Supported	N/A	-1	N/A	0.5
1310 Tx/1310 Rx	SMF	Supported	N/A	-0.5	N/A	0.5

**Table 7-6 SFP Module Cabling Specifications**

Interface Type	Fiber Type	Core Specifications ( $\mu\text{m}$ )	Max. Cabling Distance
LC	Multimode	50/125, 62.5/125	0.3 km
LC	SMF	9/125	10 km

### Caution

- For the optical module with the transmission distance exceeding 40 km (24.85 miles) or above, add one in-line optical attenuator on the link to avoid the overload of the optical receiver when short single-mode fiber-optic cables are used.
- The optical module is a laser device. Please do not look into the laser beam directly.
- To keep the optical module clean, make sure that the unused ports remain capped.