

Ruijie Reyee RG-ES206MG-P and RG-ES209MG-P Switches

Installation Guide

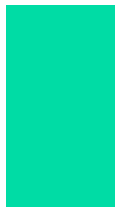
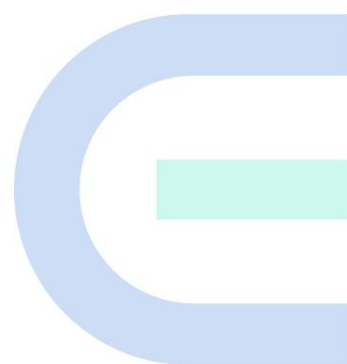

Copyright

Copyright © 2025 Ruijie Networks

All rights are reserved in this document and this statement.

Without the prior written consent of Ruijie Networks, any organization or individual shall not reproduce, extract, back up, modify, or propagate the content of this document in any manner or in any form, or translate it into other languages or use some or all parts of the document for commercial purposes.



and other Ruijie networks logos are trademarks of Ruijie Networks.

All other trademarks or registered trademarks mentioned in this document are owned by their respective owners.

Disclaimer

The products, services, or features that you purchase are subject to commercial contracts and terms. It is possible that some or all of the products, services, or features described in this document may not be available for purchase or use. Unless agreed upon otherwise in the contract, Ruijie Networks does not provide any explicit or implicit statements or warranties regarding the content of this document.

The names, links, descriptions, screenshots, and any other information regarding third-party software mentioned in this document are provided for your reference only. Ruijie Networks does not explicitly or implicitly endorse or recommend the use of any third-party software and does not make any assurances or guarantees concerning the applicability, security, or legality of such software. You should choose and use third-party software based on your business requirements and obtain proper authorization. Ruijie Networks assumes no liability for any risks or damages arising from your use of third-party software.

The content of this document is subject to constant change due to product version upgrades or other reasons. Thus, Ruijie Networks reserves the right to modify the content of the document without prior notice or prompt.

This manual serves solely as a user guide. While Ruijie Networks endeavors to ensure the accuracy and reliability of the content when compiling this manual, it does not guarantee that the content of the manual is free of errors or omissions. All information contained in this manual does not constitute any explicit or implicit warranties.

Preface

Intended Audience

This document is intended for:

- Network engineers
- Technical support and servicing engineers
- Network administrators

Technical Support

- Ruijie Reye website: <https://reyee.ruijie.com>
- Online support center: <https://reyee.ruijie.com/en-global/support>
- Case portal: <https://www.ruijie.com/support/caseportal>
- Community: <https://community.ruijie.com>
- Email support: service_rj@ruijie.com
- Live chat: <https://reyee.ruijie.com/en-global/rita>

Conventions

The signs used in this document are described as follows:

1. Signs

Danger

An alert that contains important safety instructions. Before you work on any equipment, be aware of the hazards involved and be familiar with standard practices in case of accidents.

Warning

An alert that calls attention to important rules and information that if not understood or followed can result in data loss or equipment damage.

Caution

An alert that calls attention to essential information that if not understood or followed can result in function failure or performance degradation.

Note

An alert that contains additional or supplementary information that if not understood or followed will not lead to serious consequences.

Specification

An alert that contains a description of product or version support.

2. Notes

This manual presents installation instructions, troubleshooting techniques, technical specifications, cable and connector requirements, and usage guidelines. It is intended for users who want to gain insight into the above content and have some experience in installing and maintaining network hardware. It is assumed that users are already familiar with relevant terms and concepts.

Contents

Preface	I
1 Overview	1
1.1 About the RG-ES206MG-P and RG-ES209MG-P	1
1.2 Package Contents.....	1
1.3 Product Appearance.....	2
1.3.1 RG-ES206MG-P	2
1.3.2 RG-ES209MG-P	4
1.4 Technical Specifications	6
1.4.1 RG-ES206MG-P	6
1.4.2 RG-ES209MG-P	8
1.5 Cooling.....	10
2 Preparing for Installation	11
2.1 Safety Guidelines.....	11
2.1.1 General Precautions	11
2.1.2 Chassis-Lifting Guidelines	11
2.1.3 Electric Safety	11
2.1.4 Static Electricity.....	12
2.1.5 Laser Safety	12
2.2 Site Requirements	13
2.2.1 Ventilation Requirements.....	13
2.2.2 Temperature and Humidity.....	13
2.2.3 Cleanliness.....	13

2.2.4 Grounding	14
2.2.5 Preventing Electromagnetic Interference	14
2.2.6 Surge Protection	14
2.3 Tools	15
3 Product Installation.....	16
3.1 Before You Begin.....	16
3.2 Precautions	16
3.3 Installing the RG-ES206MG-P or RG-ES209MG-P	16
3.3.1 Wall Mounting a Switch.....	16
3.3.2 Mounting a Switch on a Workbench	19
3.4 Grounding the Equipment.....	20
3.5 Connecting Cables.....	20
3.6 Checklist After Installation	20
4 Networking Configuration.....	22
4.1 Setting Up the Configuration Environment	22
4.2 Power-on.....	22
4.3 Configuring the Switch through Web Login or QR Code Scanning	23
4.3.1 Configuring the Switch through Web Login	23
4.3.2 Configuring the Switch through QR Code Scanning	23
5 Troubleshooting.....	24
5.1 Troubleshooting Flowchart	24
5.2 Common Faults and Troubleshooting	25
6 Appendix.....	27
6.1 Connectors and Media.....	27

6.1.1 10/100/1000/2500BASE-T Ports	27
6.1.2 Optical Cable Connection	28
6.2 SFP and SFP+ Transceivers	28
6.3 Surge Protection	32
6.3.1 Installing an AC Power Lightning Arrester	32
6.3.2 Installing an Ethernet Port Lightning Arrester	34

1 Overview

1.1 About the RG-ES206MG-P and RG-ES209MG-P

The RG-ES2 series 2.5 Gbps cloud-managed switches, including the RG-ES206MG-P and RG-ES209MG-P, are cost-effective products designed for home and small business scenarios.

The following table lists the port specifications for each model.

Table 1-1 Port Specifications

Model	10/100/1000/2500BASE-T Port	10GE SFP+ Port
RG-ES206MG-P	5 (PoE/PoE+ supported on ports 1 to 4)	1
RG-ES209MG-P	8 (PoE/PoE+ supported on all ports)	1

1.2 Package Contents

Table 1-2 Package Contents

No.	Item	Quantity
1	RG-ES206MG-P or RG-ES209MG-P switch	1
2	Power adapter (with slight variations between different product batches)	1
3	User Manual	1

 **Note**

The package contents are subject to the purchase contract, and actual delivery may vary. Please check the items carefully against the package contents or purchase contract. If you have any questions, please contact the distributor.

1.3 Product Appearance

1.3.1 RG-ES206MG-P

Figure 1-1 Front Panel

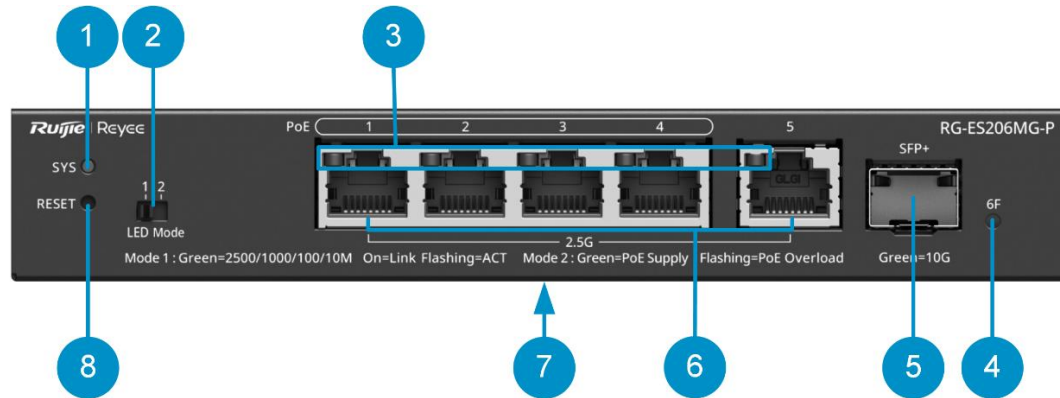

Table 1-3 Components on the Front Panel

No.	Component	Description
1	System status LED	<ul style="list-style-type: none"> ● Off: The switch is not powered on. ● Fast blinking green (10 Hz): The system is initializing or upgrading. ● Slow blinking green (0.5 Hz): The switch is operating normally, but is not connected to Ruijie Cloud. ● Solid green: The switch is operating normally, and is connected to Ruijie Cloud. ● Blinking yellow: A system alarm occurs, typically caused by insufficient PoE budget. ● Blinking red: A system failure occurs, typically caused by switch loops or PoE failures.
2	LED mode toggle	Toggle the switch to change the mode for Ethernet port LEDs. <ul style="list-style-type: none"> ● LED mode 1 (switching mode): When the switch is toggled to the left, the Ethernet port LEDs display the data transmission status. ● LED mode 2 (PoE mode): When the switch is toggled to the right, the Ethernet port LEDs display the PoE status.

No.	Component	Description
3	Ethernet port LEDs (1–5)	<p>LEDs of ports 1–4 support both switching mode and PoE mode, while the LED of port 5 supports only switching mode.</p> <ul style="list-style-type: none"> ● Switching mode: <ul style="list-style-type: none"> ○ Off: The port is not connected. ○ Solid green: The port is operating at 2500 Mbps, 1000 Mbps, 100 Mbps, or 10 Mbps, but is not receiving or sending data. ○ Blinking green: The port is operating at 2500 Mbps, 1000 Mbps, 100 Mbps, or 10 Mbps, and is receiving or sending data. ● PoE mode: <ul style="list-style-type: none"> ○ Off: PoE is disabled on the port. ○ Solid green: PoE is enabled on the port. ○ Blinking green: PoE overload occurs on the port.
4	SFP+ port LED	<ul style="list-style-type: none"> ● Off: The port is not connected. ● Solid green: The port is operating at 10 Gbps, but is not receiving or sending data. ● Blinking green: The port is operating at 10 Gbps, and is receiving or sending data.
5	SFP+ port	The port supports 10GE SFP+ transceivers and hot swapping.
6	10/100/1000/2500BASE-T ports (ports 1–5)	The ports are connected to Category 5 Enhanced (CAT5e) cables. Ports 1–4 are PoE-capable.
7	Nameplate	It is located at the bottom of the switch.
8	Reset button	<ul style="list-style-type: none"> ● Press and hold the button for less than 2s: Restart the switch. ● Press and hold the button for more than 5s: Release the button until the system status LED starts blinking to restore factory settings and restart the switch. ● Press and hold the button for 2s to 5s: No action is triggered.

Figure 1-2 Rear Panel



Table 1-4 Components on the Rear Panel

No.	Component	Description
1	Grounding stud	It is connected to a grounding wire.
2	DC power input port	<ul style="list-style-type: none"> It is connected to a 54 V DC power source to supply power to the switch. The matching DC power connector has an outer diameter of 5.5 mm (0.22 in.), an inner diameter of 2.1 mm (0.08 in.), and a depth of 10 mm (0.39 in.).

1.3.2 RG-ES209MG-P

Figure 1-3 Front Panel

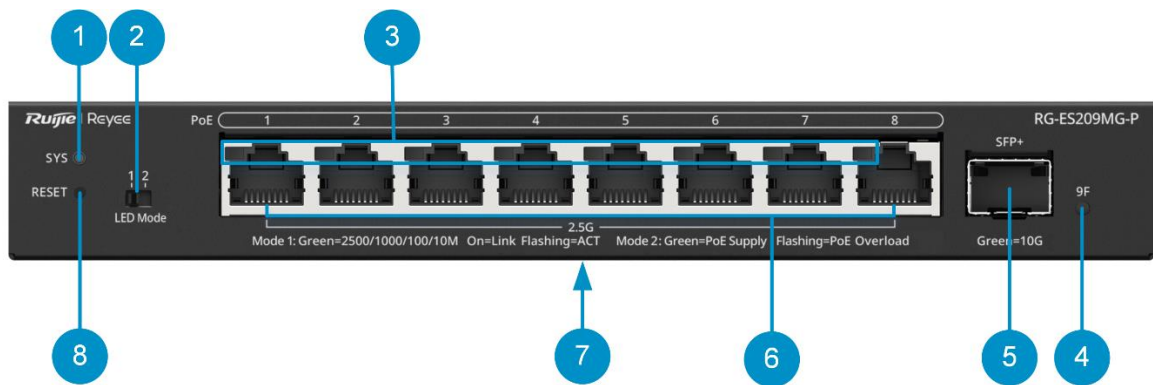

Table 1-5 Components on the Front Panel

No.	Component	Description
1	System status LED	<ul style="list-style-type: none"> Off: The switch is not powered on. Fast blinking green (10 Hz): The system is initializing or upgrading. Slow blinking green (0.5 Hz): The switch is operating normally, but is not connected to Ruijie Cloud. Solid green: The switch is operating normally, and is connected to Ruijie Cloud. Blinking yellow: A system alarm occurs, typically caused by insufficient PoE budget. Blinking red: A system failure occurs, typically caused by switch loops or PoE failures.
2	LED mode toggle	<p>Toggle the switch to change the mode for Ethernet port LEDs.</p> <ul style="list-style-type: none"> LED mode 1 (switching mode): When the switch is toggled to the left, the Ethernet port LEDs display the data transmission status. LED mode 2 (PoE mode): When the switch is toggled to the right, the Ethernet port LEDs display the PoE status.

No.	Component	Description
3	Ethernet port LEDs (1–8)	<ul style="list-style-type: none"> ● Switching mode: <ul style="list-style-type: none"> ○ Off: The port is not connected. ○ Solid green: The port is operating at 2500 Mbps, 1000 Mbps, 100 Mbps, or 10 Mbps, but is not receiving or sending data. ○ Blinking green: The port is operating at 2500 Mbps, 1000 Mbps, 100 Mbps, or 10 Mbps, and is receiving or sending data. ● PoE mode: <ul style="list-style-type: none"> ○ Off: PoE is disabled on the port. ○ Solid green: PoE is enabled on the port. ○ Blinking green: PoE overload occurs on the port.
4	SFP+ port LED	<ul style="list-style-type: none"> ● Off: The port is not connected. ● Solid green: The port is operating at 10 Gbps, but is not receiving or sending data. ● Blinking green: The port is operating at 10 Gbps, and is receiving or sending data.
5	SFP+ port	The port supports 10GE SFP+ transceivers and hot swapping.
6	10/100/1000/2500BASE-T ports (ports 1–8)	The ports are connected to CAT5e cables. Ports 1–8 are PoE-capable.
7	Nameplate	It is located at the bottom of the switch.
8	Reset button	<ul style="list-style-type: none"> ● Press and hold the button for less than 2s: Restart the switch. ● Press and hold the button for more than 5s: Release the button until the system status LED starts blinking to restore factory settings and restart the switch. ● Press and hold the button for 2s to 5s: No action is triggered.

Figure 1-4 Rear Panel

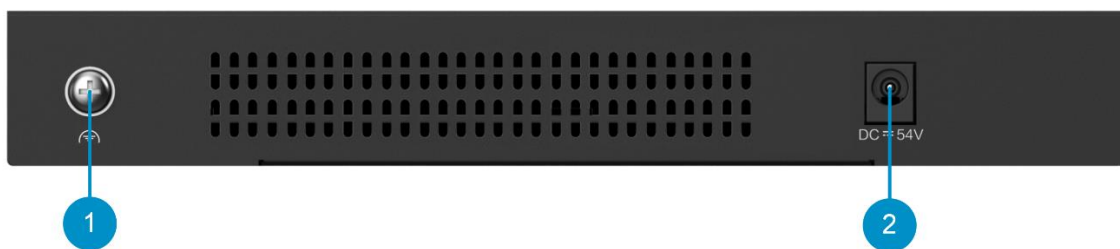

Table 1-6 Components on the Rear Panel

No.	Component	Description
1	Grounding stud	It is connected to a grounding wire.

No.	Component	Description
2	DC power input port	<ul style="list-style-type: none"> ● It is connected to a 54 V DC power source to supply power to the switch. ● The matching DC power connector has an outer diameter of 5.5 mm (0.22 in.), an inner diameter of 2.5 mm (0.08 in.), and a depth of 10 mm (0.39 in.).

1.4 Technical Specifications



Warning

- This is a Class A product. The equipment room should be located away from residential areas. Equipment rooms near residential areas should meet construction specifications to avoid noise and radio interference.
- This equipment is not suitable for use in locations where children are likely to be present.

1.4.1 RG-ES206MG-P

Table 1-7 Technical Specifications

System Specifications	Flash memory	4 MB
	Forwarding rate	33.75 Mpps
Port Specifications	Total number of RJ45 ports	5
	Total number of optical ports	1
	Number of 10GE SFP+ ports	1
	Number of 10/100/1000/2500BASE-T ports	5
	Reset button	1
	DIP switch	<ul style="list-style-type: none"> ● LED mode switch toggled to left (Mode 1): The port LED status indicates the status of traffic transmission. Solid green means that the port is link up, while blinking green means that the port is transmitting and receiving data. ● LED mode switch toggled to right (Mode 2): The port LED status indicates the PoE status. Solid green means that the port is supplying power, while blinking green means that the port is in power overload state.
	PoE Out standard	PoE/PoE+ (IEEE 802.3af/at)

Power Supply and Consumption	Number of PoE/PoE+ Out ports	4
	PoE budget per port	30 W
	PoE budget	70 W
	PoE power pins	1–2 (+), 3–6 (-)
	Power supply	DC power adapter
	Power input	DC adapter: <ul style="list-style-type: none"> ● Rated input voltage: 100 V AC to 240 V AC, 50 Hz to 60 Hz ● Maximum input voltage: 90 V AC to 264 V AC, 47 Hz to 63 Hz ● Rated input current: 1.5 A Output: <ul style="list-style-type: none"> ● Rated output voltage: 54 V DC ● Maximum output current: 1.48 A
	Maximum power consumption	<ul style="list-style-type: none"> ● 5.5 W (with no PoE load) ● 75.5 W (with PoE full load)
	Power supply to external devices	Ethernet interfaces 1 to 4 can provide external power supply of 54 V/30 W
Dimensions and Weight	Casing	Metal
	Product dimensions (W x D x H)	172 mm x 90.8 mm x 28 mm (6.77 in. x 3.57 in. x 1.1 in.)
	Weight	0.49 kg (1.08 lbs) (without packaging materials) 1.39 kg (3.06 lbs) (with packaging materials)
	Shipping weight	1.39 kg (3.06 lbs)
System Specifications	Switching capacity	45 Gbps (bit/s)
Environment and Reliability	Fan	Fanless design
	Cooling	Natural cooling
	Mounting options	Wall/Desk
	Hot swapping of cables	Hot swapping supported by the service port and power connector
	MTBF	200,000 hours
	Operating temperature	0°C to 40°C (32°F to 104°F)
	Storage temperature	-40°C to +70°C (-40°F to +158°F)

	Operating humidity	10% RH to 90% RH (non-condensing)
	Storage humidity	5% RH to 95% RH (non-condensing)
	Altitude	-500 m to +5,000 m (-1,640.42 ft. to +16,404.20 ft.)
	ESD protection	<ul style="list-style-type: none"> ● Air discharge: 8 kV ● Contact discharge: 6 kV
	Surge protection	<ul style="list-style-type: none"> ● Service port: ±4 kV for common mode ● Power connector: ±4 kV for common mode and ±4kV for differential mode
Certification and Regulatory Compliance	EMC	EN 55032 EN 61000-3-2 EN 61000-3-3 EN 55035 EN 300 386
	Safety compliance	EN 62638-1
	Certification	CE
Interface	EEE	Yes

1.4.2 RG-ES209MG-P

Table 1-8 Technical Specifications

System Specifications	Flash memory	4 MB
	Forwarding rate	45 Mpps
Port Specifications	Total number of RJ45 ports	8
	Total number of optical ports	1
	Number of 10GE SFP+ ports	1
	Number of 10/100/1000/2500BASE-T ports	8
	Reset button	1
	DIP switch	<ul style="list-style-type: none"> ● LED mode switch toggled to left (Mode 1): The port LED status indicates the status of traffic transmission. Solid green means that

		<p>the port is link up, while blinking green means that the port is transmitting and receiving data.</p> <ul style="list-style-type: none"> ● LED mode switch toggled to right (Mode 2): The port LED status indicates the PoE status. Solid green means that the port is supplying power, while blinking green means that the port is in power overload state.
Power Supply and Consumption	PoE Out standard	PoE/PoE+ (IEEE 802.3af/at)
	Number of PoE/PoE+ Out ports	8
	PoE budget per port	30 W
	PoE budget	130 W
	PoE power pins	1–2 (+), 3–6 (-)
	Power supply	DC power adapter
	Power input	<p>DC adapter:</p> <ul style="list-style-type: none"> ● Rated input voltage: 100 V AC to 240 V AC, 50 Hz to 60 Hz ● Maximum input voltage: 90 V AC to 264 V AC, 47 Hz to 63 Hz ● Rated input current: 2.5 A <p>Output:</p> <ul style="list-style-type: none"> ● Rated output voltage: 54 V DC ● Maximum output current: 2.78 A
	Maximum power consumption	<ul style="list-style-type: none"> ● 8.5 W (with no PoE load) ● 138.5 W (with PoE full load)
Power supply to external devices	Ethernet interfaces 1 to 8 can provide external power supply of 54 V/30 W	
Dimensions and Weight	Casing	Metal
	Product dimensions (W x D x H)	202 mm x 108 mm x 28 mm (7.95 in. x 4.25 in. x 1.1 in.)
	Weight	<ul style="list-style-type: none"> ● 0.66 kg (1.46 lbs) (without packaging materials) ● 1.63 kg (3.59 lbs) (with packaging materials)
System Specifications	Switching capacity	60 Gbps (bit/s)
Environment and Reliability	Fan	Fanless design
	Cooling	Natural cooling
	Mounting options	Wall/Desk

	Hot swapping of cables	Hot swapping supported by the service port and power connector
	MTBF	200,000 hours
	Operating temperature	0°C to 40°C (32°F to 104°F)
	Storage temperature	-40°C to +70°C (-40°F to +158°F)
	Operating humidity	10% RH to 90% RH (non-condensing)
	Storage humidity	5% RH to 95% RH (non-condensing)
	Altitude	-500 m to +5,000 m (-1,640.42 ft. to +16,404.20 ft.)
	ESD protection	<ul style="list-style-type: none"> ● Air discharge: 8 kV ● Contact discharge: 6 kV
	Surge protection	<ul style="list-style-type: none"> ● Service port: ±4 kV for common mode ● Power connector: ±4 kV for common mode and ±4 kV for differential mode
Certification and Regulatory Compliance	EMC	EN 55032 EN 61000-3-2 EN 61000-3-3 EN 55035 EN 300 386
	Safety compliance	EN 62638-1
	Certification	CE
Interface	EEE	Yes

1.5 Cooling

The RG-ES206MG-P and RG-ES209MG-P both adopt natural cooling. To ensure that the switches work properly in the specified environment, a minimum clearance of 10 cm (3.94 in.) must be maintained around the devices to ensure proper ventilation. Dust a switch every three months to avoid blocking the ventilation openings on the housing.

Note

The ventilation openings of the RG-ES206MG-P are located on the left and right sides, while the RG-ES209MG-P has ventilation openings on the left, right, and rear sides.

2 Preparing for Installation

2.1 Safety Guidelines

Note

- To avoid personal injury and equipment damage, review the safety guidelines in this chapter before you begin the installation.
 - The following safety guidelines may not include all the potentially hazardous situations.
-

2.1.1 General Precautions

- Do not place the switch in a wet position, and keep the switch away from liquid. Keep the chassis clean and dust-free.
- Keep the equipment away from heat sources.
- Keep the equipment away from walking areas.
- During the installation and maintenance, do not wear loose clothes, ornaments, or any other things that may be hooked by the device.

2.1.2 Chassis-Lifting Guidelines

- Avoid moving the equipment frequently.
- Turn off all power supplies and disconnect all power cords before lifting or moving the equipment.
- Keep balance and prevent personal injuries when handling the equipment.

2.1.3 Electric Safety

Warning

- Any deviation from standard or improper electrical operations can result in accidents such as fires or electric shocks, potentially causing severe or even fatal harm to both individuals and equipment.
 - Direct or indirect touch through a wet object on high-voltage and mains supply can bring a fatal danger.
-

- Always observe the local regulations and standards. Only trained and qualified personnel should be allowed to operate the device.
- Carefully check the work area for potential hazards, including ungrounded power system, absent safety grounds, and damp floors.
- Locate the emergency power-off switch in the room. In the case of an electrical accident, cut off the power supply immediately.
- Be sure to make a careful check before shutting down the power supply.
- Equip the power supply system with a leakage protector (also referred to as "leakage current switch" or "leakage current breaker") to automate the power cut-off in the case of power leakage or shock. When selecting the leakage protector, observe the following rule:
 - The rated leakage action current of each leakage protector is greater than twice of the theoretical

maximum leakage current of all the power supplies in the system.

- For example, if a system is equipped with 16 identical power supplies, the leakage current of each power supply is at most 3.5 mA, and the leakage current of the system totals 56 mA (maximum theoretical value). A leakage protector with 30 mA rated action current supports less than nine power supplies (that is, Action current of the leakage protector/2/Maximum leakage current of each power supply = $30/2/3.5 \approx 4.28$). In other words, the leakage protector with a rated action current of 30 mA supports up to four power supplies. In this case, the 16 power supplies in the system require at least four leakage protectors with a rated action current of 30 mA and each leakage protector supports four power supplies.
- If power supplies in a system differ in models, the rated leakage action current of each leakage protector divided by two is greater than the sum of maximum leakage currents of all the power supplies.
- The rated leakage non-action current of a leakage protector shall be 50% of the leakage action current. If the non-action current value is too small, the high sensitivity level may cause the circuit to break, causing power cut-off and service interruption even if the leakage current value is normal.
- Take a leakage protector with a rated action current of 30 mA as an example. The rated leakage non-action current shall be 15 mA. When the leakage current is less than 15mA, the protector shall not act.

⚠ Caution

To guarantee personal safety, the rated leakage action current of each leakage protector in the system must be equal to or less than 30 mA (human body safety current is 30 mA). When twice of the total leakage current of the system is greater than 30 mA, the system must be equipped with two or more leakage protectors.

2.1.4 Static Electricity

- Ensure that the chassis is connected to earth ground. Ensure that the AC power socket is a single-phase three-core power socket with protective earthing conductors (PE).
- Keep the site as dust free as possible.
- Maintain appropriate humidity conditions.

2.1.5 Laser Safety

The equipment supports various types of optical transceivers, which are Class I laser products.

- When a media converter is working, ensure that its port is connected to an optical cable or covered by a dust cap to keep out dust and prevent it from burning your eyes.
- Do not stare into an optical port.

Figure 2-1 Laser Product Label



⚠ Caution

Do not approach or look into any optical port under any circumstances. This may cause permanent damage to your eyes.

2.2 Site Requirements

The equipment must be installed indoors for normal operation and prolonged service life.

The installation site must meet the following requirements.

2.2.1 Ventilation Requirements

- Maintain a minimum clearance of 100 mm (3.94 in.) around the switch for air circulation and ventilation.
- After the cables are connected, bundle the cables or place them in the patch panel to avoid blocking air inlets.

2.2.2 Temperature and Humidity

To ensure the normal operation and a prolonged service life of the device, maintain an appropriate temperature and humidity in the installation environment.

- In an environment with a high relative humidity, insulating materials are prone to poor insulation or even electricity leakage.
- In an environment with a low relative humidity, insulating gaskets may shrink, resulting in screw loosening.
- In a dry environment, static electricity is more likely to occur, posing a risk to the internal circuits of equipment.
- A high temperature can accelerate the aging process of insulation materials, greatly reducing the availability of the equipment and severely affecting its service life.

2.2.3 Cleanliness

Dust poses a significant hazard to the equipment. The indoor dust takes on a positive or negative static electric charge when falling on the switch, causing poor contact of the metallic joint. Such electrostatic adhesion may occur more easily when the relative humidity is low, not only affecting the service life of the equipment, but also causing communication faults. The following table lists the requirements for dust concentration and particle size in the equipment room.

Table 2-1 Requirements for Dust

Dust	Unit	Concentration
≥ 0.5 μm	Particles/m ³	≤ 3.5 × 10 ⁶
≥ 5 μm	Particles/m ³	≤ 3.5 × 10 ⁴

Apart from dust, there are also requirements on the salt, acid, and sulfide in the air of the equipment room. These harmful substances will accelerate metal corrosion and component aging. Therefore, the equipment room should be properly protected against the intrusion of harmful gases, such as sulfur dioxide, hydrogen sulfide, nitrogen dioxide, and chlorine gas. The following table lists limit values for harmful gases.

Table 2-2 Requirements for Gases

Gas	Average (mg/m ³)	Maximum (mg/m ³)
Sulfur dioxide (SO ₂)	0.3	1.0
Hydrogen sulfide (H ₂ S)	0.1	0.5
Nitrogen dioxide (NO ₂)	0.5	1.0
Chlorine gas (Cl ₂)	0.1	0.3

i Note

Average refers to the average value of harmful gases measured in a week. Maximum refers to the upper limit of harmful gases measured in one week, and the maximum value cannot last for more than 30 minutes every day.

2.2.4 Grounding

A proper grounding system is crucial for ensuring stable and reliable operation, as well as preventing lightning strikes and interference. Carefully check the grounding conditions at the installation site according to the grounding requirements, and complete grounding properly based on the site situation.

Electromagnetic compatibility (EMC) grounding includes shielded grounding, filter grounding, noise and interference suppression, and level reference.

i Note

- The grounding resistance should be smaller than 1 ohm.
 - Connect the grounding stud to the ground before operating the equipment.
 - The grounding wire of the switch is not delivered with the switch and needs to be purchased by the customer.
-

2.2.5 Preventing Electromagnetic Interference

- Take interference prevention measures for the power supply system.
- Keep the equipment far away from the grounding system or lightning protection grounding system of the power facility.
- Keep the equipment far away from high-frequency current equipment such as a high-power radio transmitting stations and radar launchers.
- Take electromagnetic shielding measures when necessary.

2.2.6 Surge Protection

Although the equipment can guard against lightning strikes, strong lightning strikes may still damage the equipment. Take the following surge protection measures:

- Ensure that the grounding wire of the rack is in good contact with the ground.
- Ensure that the neutral point of the AC power socket is in good contact with the ground.

- Install a power arrester in front of the power input end to enhance surge protection for the power supply.

2.3 Tools

Table 2-3 Tools

Common Tools	Phillips screwdriver, power cords, Ethernet cables, cage nuts, diagonal pliers, cable ties, and optical cables
Special Tools	ESD-preventive glove, wire stripper, crimper, RJ45 connector crimping plier, and wire cutter
Meters	Multimeter
Relevant Equipment	PC, display, and keyboard

 **Note**

The equipment is not shipped with a tool kit. You need to prepare a tool kit by yourself.

3 Product Installation

Caution

Before installing the equipment, ensure that guidelines and requirements in Chapter 2 have been met.

3.1 Before You Begin

- The installation site provides sufficient space for heat dissipation.
- The installation site meets the temperature and humidity requirements.
- The power supply is available at the installation site, and its current meets the requirements.
- The Ethernet cables have been deployed at the installation site.
- Locate the emergency power-off switch in the room before installation. In the case of an accident, cut off the power supply immediately.

3.2 Precautions

To ensure normal operation and prolong the service life of the equipment, observe the following safety precautions:

- Do not power on the equipment during installation.
- Place the equipment in a well-ventilated environment.
- Do not expose the equipment to high temperatures.
- Keep the equipment away from high-voltage power cables.
- Install the equipment indoors.
- Do not expose the equipment to a thunderstorm or strong electric field.
- Keep the equipment clean and dust-free.
- Cut off the power supply before cleaning the equipment.
- Do not wipe the equipment with a damp cloth.
- Do not wash the equipment with liquid.
- Do not open the enclosure when the equipment is working.
- Secure the equipment properly.

3.3 Installing the RG-ES206MG-P or RG-ES209MG-P

3.3.1 Wall Mounting a Switch

Note

- The equipment can be mounted on a wall. Two M3 screws and two plastic expansion anchors must be prepared by yourself.
-

- When the equipment is mounted on a wall, it is only suitable to be mounted on a concrete or non-flammable surface.
-

Table 3-1 Drilling Distances for Wall Mounting Switches

Model	Drilling Distance
RG-ES206MG-P	100 mm (3.94 in.)
RG-ES209MG-P	120 mm (4.72 in.)

The steps for wall mounting a switch are as follows:

- (1) Drill two holes at suitable positions on the wall based on the hole spacing of the corresponding device model. The hole diameter and depth depend on the specifications of the purchased plastic expansion anchors.
- (2) Insert two plastic expansion anchors into the drilled holes, and then screw two M3 screws into the plastic expansion anchors.

 Note

Ensure that the distance between the inner side of the screw heads and the outer edge of the plastic expansion anchors is at least 2.5 mm (0.1 in.) to securely mount the switch onto the screws.

- (3) Mount the switch onto the M3 screws.

Mount the RG-ES206MG-P and RG-ES209MG-P, as shown in the following figures.

Figure 3-1 Wall Mounting the RG-ES206MG-P

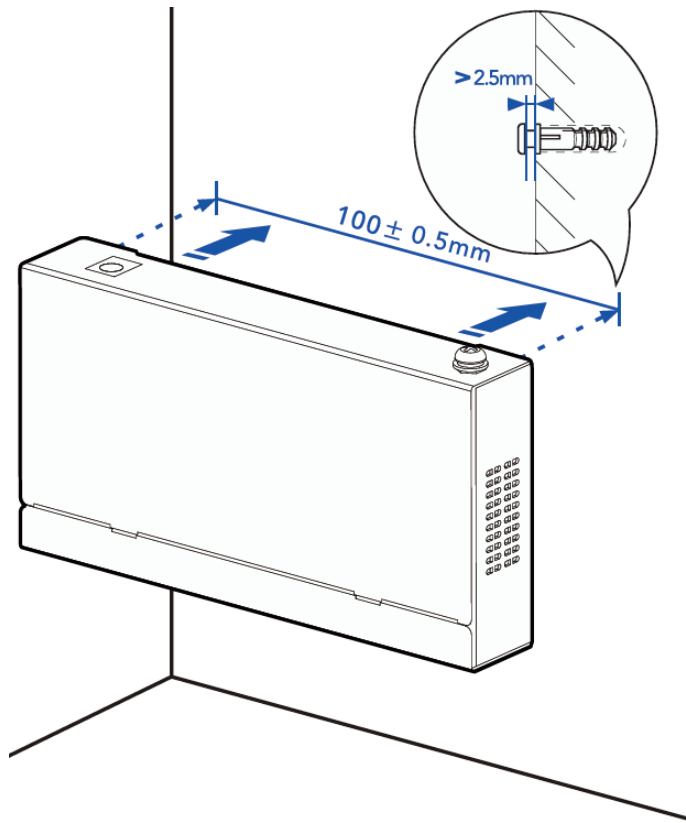
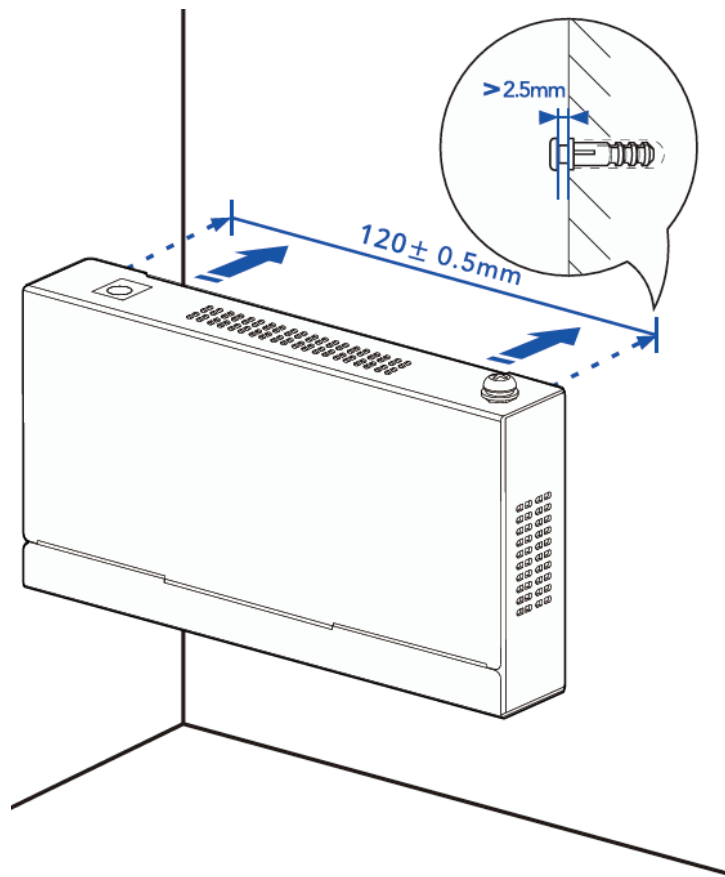

Figure 3-2 Wall Mounting the RG-ES209MG-P



3.3.2 Mounting a Switch on a Workbench

If wall mounting a switch is not available, install it on a clean workbench.

⚠ Caution

The switch must be installed in a location where movement is restricted.

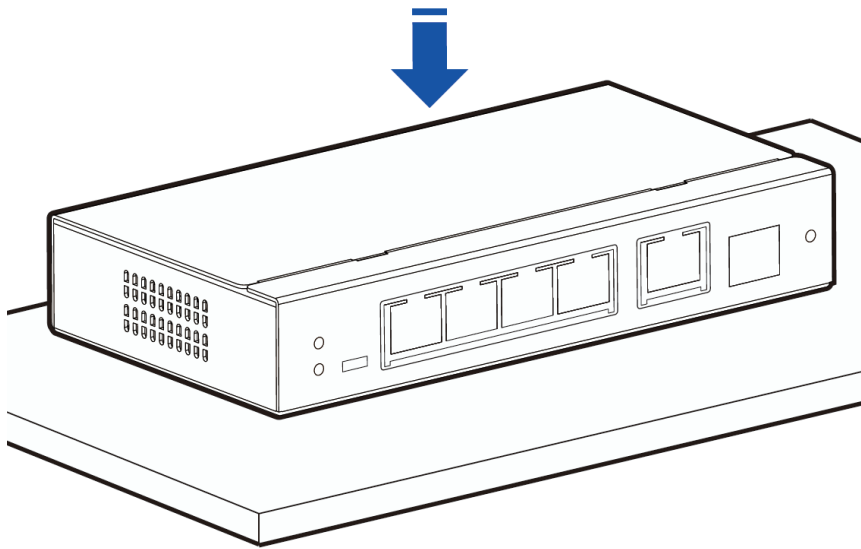
Figure 3-3 Mounting a Switch on a Workbench (Using the RG-ES206MG-P as an Example)

3.4 Grounding the Equipment

Connect the grounding wire at the installation site to the grounding stud on the rear panel of a switch.

Note

The grounding wire is not delivered with the switch. Please purchase it based on actual requirements.

3.5 Connecting Cables

- (1) Connect the power adapter. Insert one end of the power adapter into the switch's power input port and the other end into the power strip. Before plugging in, ensure that the power strip is turned off.
- (2) Connect Ethernet cables. Connect one end of a CAT5e cable to the device's Ethernet port, and the other end to the downstream device.
- (3) Connect optical cables. Insert the optical transceivers into optical ports according to the panel identification. Then connect single-mode fibers (SMFs) and multimode fibers (MMFs) to the corresponding optical transceivers, during which the transmitting and receiving ends of the optical cables should be distinguished. For details, see [6.1.2 Optical Cable Connection](#).

3.6 Checklist After Installation

Caution

Please turn off the power to avoid personal injury and damage to components caused by incorrect connection.

- Verify that the grounding wire is connected.
- Verify that the Ethernet cables and power cord are properly connected.
- Check whether the Ethernet cables with a distance of 100 m (328.08 ft.) are routed indoors. If not, check

whether the power strip with surge protection, Ethernet surge protector, and others are installed for the AC power supply.

- Verify that there is a minimum clearance of 10 cm (3.94 in.) around the switch.

4 Networking Configuration

4.1 Setting Up the Configuration Environment

Connect a PC to the switch's Ethernet port using an Ethernet cable.

Figure 4-1 Configuring Environment

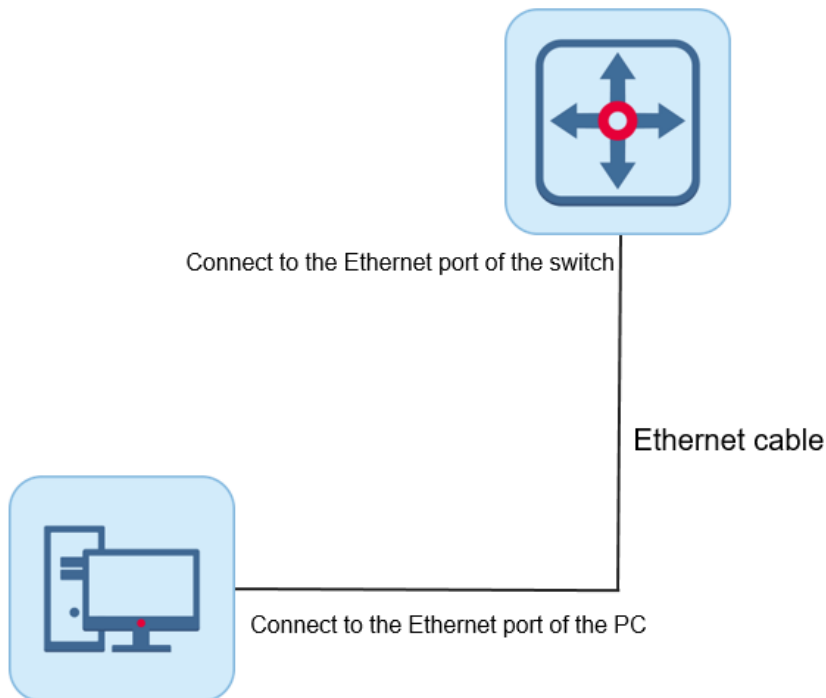

4.2 Power-on

(1) Check the items before power-on.

- The equipment is properly grounded.
- The power cord is reliably connected.
- The input voltage meets the requirement.
- The Ethernet cable is properly connected, and the client such as a PC used for configuration is already turned on.

(2) Power on the equipment.

(3) Check the items after power-on.

After the equipment is powered on, check the following items:

- The system status LED works properly.
- Service ports can forward data properly.

4.3 Configuring the Switch through Web Login or QR Code Scanning

4.3.1 Configuring the Switch through Web Login

- (1) Set the IP address of the PC to 10.44.77.XXX (Range: 1–254, excluding 200).

Figure 4-2 Changing the PC's IP Address

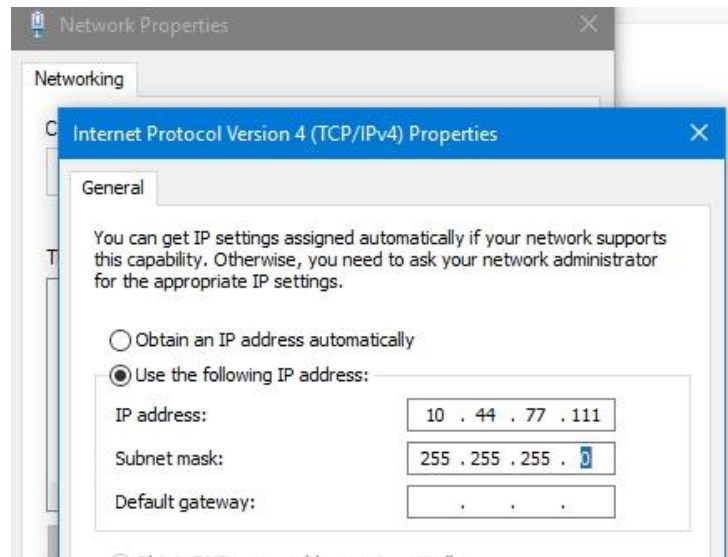

- (2) Open your browser, enter 10.44.77.200 in the address bar, and log in to the management system after setting a password.
- (3) Perform device commissioning and configuration based on service requirements.

Note

For security purposes, you are advised to change the password regularly.

4.3.2 Configuring the Switch through QR Code Scanning

Scan the following QR code or that on the switch to download Ruijie Reyee App. Then configure the network.

Figure 4-3 QR Code for Downloading Ruijie Reyee App



i Note

The QR code for downloading Ruijie Reyee App is located at the upper left corner of the device's top panel.

5 Troubleshooting

5.1 Troubleshooting Flowchart

i Note

You can determine whether each checking item in the process is normal based on the information provided in the previous "Overview" and "Product Installation" sections.

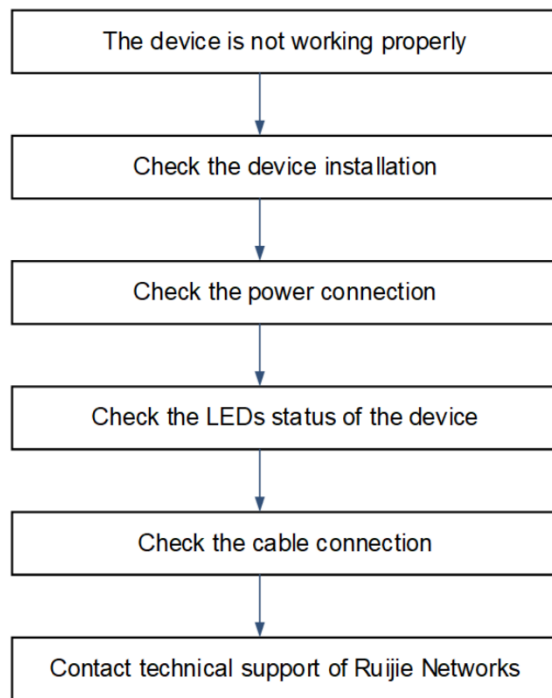
Figure 5-1 General Troubleshooting Flowchart

5.2 Common Faults and Troubleshooting

Fault Symptom	Possible Cause	Suggested Action
The system status LED is off after the switch is powered on.	No power is supplied to the switch or the power cord is loose.	Check whether the power socket in the equipment room is normal and whether the power cord connected to the switch is loose.
The RJ45 port is disconnected or an error occurs in the transmission and receiving of frames.	The twisted pair cable is not connected properly.	Replace the twisted pair cable.
	The cable length exceeds 100 m (328.08 ft.).	Use an optical cable for data transmission or connect to an intermediate switch for relay.
	The port is specially configured and does not use the same work mode as the interconnected switch.	Check whether the port is configured to work in the same mode as that of the interconnected switch.
An optical port is not reachable.	The transmit and received ends are connected incorrectly.	Exchange the transmit and received ends of the optical cable.
	The types of the interconnected optical transceivers do not match.	Replace the optical transceiver with another one of the same type.

Fault Symptom	Possible Cause	Suggested Action
	The optical cable type does not meet the requirements.	Replace the optical cable with a qualified one.
	The optical cable length is beyond the allowed length marked on the optical transceiver.	Use an optical cable with the required length.
	The optical cable or connector is contaminated.	Clean the connector with a lint-free cloth or a cleaning pen.
The login password cannot be retrieved.	The password is forgotten, and the device is neither networked nor connected to Ruijie Cloud.	Press and hold the Reset button to restore to factory settings.
	If the device is connected to Ruijie Cloud or networked, its login password is updated to the project or global management password.	If the device is connected to the cloud, log in using the project management password. If the device is networked, log in using the global management password.
The Ethernet ports are transmitting and receiving frames normally, but their LEDs are off.	<p>The LED mode toggle is incorrectly set.</p> <p>The LED mode toggle is set to LED mode 2. As a result, the Ethernet port LEDs display the PoE status, but PoE is disabled on the ports.</p>	Set the LED mode toggle to LED mode 1 so that the Ethernet port LEDs display the data receiving and sending status.

6 Appendix

6.1 Connectors and Media

6.1.1 10/100/1000/2500BASE-T Ports

10/100/1000/2500BASE-T ports are Ethernet ports with auto-negotiation of four speeds: 10 Mbps, 100 Mbps, 1000 Mbps and 2500 Mbps. They supports auto MDI/MDIX Crossover, and use RJ 45 connectors.

Compliant with IEEE 802.3ab, a 2500BASE-T or 1000BASE-T port connects to a Category 5 or CAT5e 100-ohm Unshielded Twisted Pair (UTP) or recommended Shielded Twisted Pair (STP) cable with a maximum distance of 100 meters (328.08 feet).

The 2500BASE-T or 1000BASE-T port requires that all four pairs of wires be connected for data transmission.

[Figure 6-1](#) shows the four pairs of wires for the 2500BASE-T or 1000BASE-T port.

Figure 6-1 2500BASE-T/1000BASE-T Twisted Pair Connections

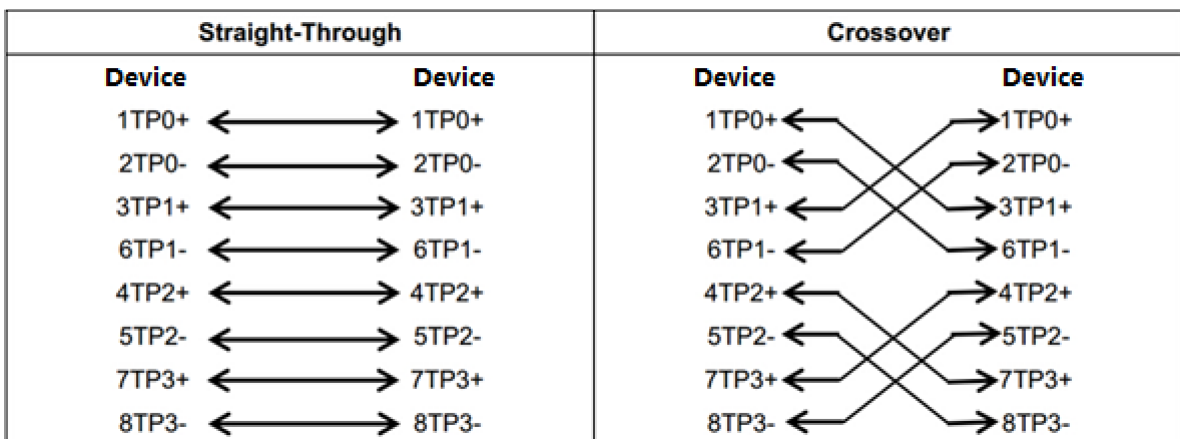

100BASE-TX/10BASE-T ports can be interconnected using cables of the preceding specifications. In addition, a 10BASE-T port can be connected using 100-ohm Category 3, Category 4, and Category 5 cables, while a 100BASE-TX port can be connected using 100-ohm Category 5 cables, and supports a maximum distance of 100 meters (328 feet). [Table 6-1](#) shows 100BASE-TX/10BASE-T pin assignments.

Table 6-1 100BASE-TX/10BASE-T Pin Assignments

Pin	Socket	Plug
1	Input Receive Data+	Output Transmit Data+
2	Input Receive Data-	Output Transmit Data-
3	Output Transmit Data+	Input Receive Data+
6	Output Transmit Data-	Input Receive Data-
4, 5, 7, 8	Not Used	Not Used

Figure 6-2 shows the connection of straight-through and crossover cables for 100BASE-TX/10BASE-T ports.

Figure 6-2 100BASE-TX/10BASE-T Twisted Pair Connections

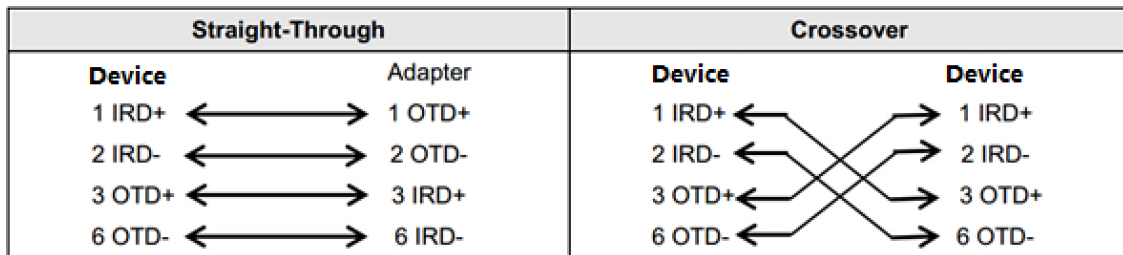

6.1.2 Optical Cable Connection

You can choose SMF or MMF optical cables based on the type of optical transceiver connected to the optical port. Figure 6-3 shows the connection.

Figure 6-3 Connecting the Optical Cables



6.2 SFP and SFP+ Transceivers

Ruijie provides SFP transceivers (mini-GBIC) and SFP+ transceivers based on the port types. You can select one that suits your specific needs. In addition to the following SFP optical transceivers, the Mini-GBIC-GT for photoelectric conversion is also supported. This document provides models and technical specifications of some 1GE SFP transceivers and 10GE SFP+ transceivers for reference.

Table 6-2 1GE Mini-GBIC (SFP) Models and Technical Specifications

Model	Wavelength (nm)	Fiber Type	DDM Supported (Yes/No)	Transmit Power (dBm)		Receive Power (dBm)	
				min	max	min	max
MINI-GBIC-SX-MM850	850	MMF	Yes	-9.5	0	-17	0
MINI-GBIC-LX-SM1310	1310	SMF	Yes	-11	-3	-19	-3

Model	Wavelength (nm)	Fiber Type	DDM Supported (Yes/No)	Transmit Power (dBm)		Receive Power (dBm)	
				min	max	min	max
MINI-GBIC-LH40-SM1310	1310	SMF	Yes	-5	0	-23	-3
GE-SFP-LX20-SM1310-BIDI	1310TX/1550RX	SMF	Yes	-9	-3	-20	-3
GE-SFP-LX20-SM1550-BIDI	1550TX/1310RX	SMF	Yes	-9	-3	-20	-3
GE-SFP-LH40-SM1310-BIDI	1310TX/1550RX	SMF	Yes	-5	0	-23	-3
GE-SFP-LH40-SM1550-BIDI	1550TX/1310RX	SMF	Yes	-5	0	-23	-3
MINI-GBIC-ZX80-SM1550	1550	SMF	Yes	0	5	-27	-3

Table 6-3 1GE SFP Copper Transceivers

Standard	1000BASE-T SFP Model	DDM Supported (Yes/No)
1000Base-T	Mini-GBIC-GT	No

Table 6-4 Cabling Specifications of SFP Transceivers

Model	Port Type	Fiber Type	Core Size (um)	Max Cabling Distance
MINI-GBIC-SX-MM850	LC	MMF	62.5/125	275 m (902.23 ft.)
			50/125	550 m (1804.46 ft.)
MINI-GBIC-LX-SM1310	LC	SMF	9/125	10 km (6.21 miles)
MINI-GBIC-LH40-SM1310	LC	SMF	9/125	40 km (24.85 miles)
GE-SFP-LX20-SM1310-BIDI	LC	SMF	9/125	20 km

Model	Port Type	Fiber Type	Core Size (um)	Max Cabling Distance
				(12.43 miles)
GE-SFP-LX20-SM1550-BIDI	LC	SMF	9/125	20 km (12.43 miles)
GE-SFP-LH40-SM1310-BIDI	LC	SMF	9/125	40 km (24.85 miles)
GE-SFP-LH40-SM1550-BIDI	LC	SMF	9/125	40 km (24.85 miles)
MINI-GBIC-ZX80-SM1550	LC	SMF	9/125	80 km (49.71 miles)
Mini-GBIC-GT	RJ45	CAT5 (or higher) UTP or STP cable		100 m (62.14 miles)

⚠ Caution

- For optical transceivers with a cabling distance of no less than 40 km (24.85 miles), install an optical attenuator to avoid overload when using short-distance SMFs.
- An optical transceiver is a laser transmitter. Do not look into the light source to prevent it from burning your eyes.
- To keep the optical transceiver clean, make sure that the unused ports remain capped.

Table 6-5 Pairing 1GE BIDI Optical Transceivers

Rate/Distance	Pairing Model
1000 Mbps/20 km (12.43 miles)	<ul style="list-style-type: none"> ● GE-SFP-LX20-SM1310-BIDI ● GE-SFP-LX20-SM1550-BIDI
1000 Mbps/40 km (24.85 miles)	<ul style="list-style-type: none"> ● GE-SFP-LH40-SM1310-BIDI ● GE-SFP-LH40-SM1550-BIDI

⚠ Caution

BIDI optical transceivers must be used in pairs. For example, if GE-SFP-LX20-SM1310-BIDI is used at one end, GE-SFP-LX20-SM1550-BIDI then must be used at the other end.

The following table lists 10GE SFP+ optical transceivers.

Table 6-6 Models and Technical Specifications of 10GE SFP+ Transceivers

Model	Wavelength (nm)	Fiber Type	DDM Supported (Yes/No)	Transmit Power (dBm)		Receive Power (dBm)	
				min	max	min	max
XG-SFP-SR-MM850	850	MMF	Yes	-7.3	-1	-11.1	-1
XG-SR-MM850	850	MMF	Yes	-7.3	-1	-11.1	-1
XG-SFP-LR-SM1270-BIDI	1270TX/1330RX	SMF	Yes	-8.2	0.5	-14.4	0.5
XG-SFP-LR-SM1330-BIDI	1330TX/1270RX	SMF	Yes	-8.2	0.5	-14.4	0.5
XG-LR-SM1310	1310	SMF	Yes	-8.2	0.5	-12.6	0.5
XG-SFP-LR-SM1310	1310	SMF	Yes	-8.2	0.5	-12.6	0.5
XG-SFP-ER-SM1550	1550	SMF	Yes	-4.7	4	-14.1	-1
XG-SFP-ZR-SM1550	1550	SMF	Yes	0	4	-24	-7

Table 6-7 10GE SFP+ Active Optical Cables

Model	Type	Connector Type	Copper Cable Length (m)	Conductor Diameter (AWG)	Data Speed (Gbps)	DDM Supported (Yes/No)
XG-SFP-AOC1M	Active	SFP+	1	N/A	10.3125	Yes
XG-SFP-AOC3M	Active	SFP+	3	N/A	10.3125	Yes
XG-SFP-AOC5M	Active	SFP+	5	N/A	10.3125	Yes

Note

- SFP+ transceiver types are subject to change without prior notice. For more accurate information about the optical transceivers, contact the Ruijie marketing or technical support personnel.
- The DDM function of the AOC cable does not report transmit power, and the transmit power may be displayed as N/A.

Table 6-8 Cabling Specifications of SFP+ Transceivers

Model	Port Type	Fiber Type	Core Size (um)	Modular Bandwidth (MHz-km)	Max Cabling Distance
XG-SFP-SR-MM850	LC	MMF	50/125	2000(OM3)	300 m (984.25 ft.)
XG-SR-MM850	LC	MMF	50/125	2000(OM3)	300 m (984.25 ft.)
XG-SFP-LR-SM1270-BIDI	LC	SMF	9/125	N/A	10 km (6.21 miles)
XG-SFP-LR-SM1330-BIDI	LC	SMF	9/125	N/A	10 km (6.21 miles)
XG-LR-SM1310	LC	SMF	9/125	N/A	10 km (6.21 miles)
XG-SFP-LR-SM1310	LC	SMF	9/125	N/A	10 km (6.21 miles)
XG-SFP-ER-SM1550	LC	SMF	9/125	N/A	40 km (24.85 miles)
XG-SFP-ZR-SM1550	LC	SMF	9/125	N/A	80 km (49.71 miles)

6.3 Surge Protection

6.3.1 Installing an AC Power Lightning Arrester

When an AC power cord from outdoors is directly plugged into the power port of the equipment, the AC power connector must be connected to an external surge protector power strip to protect the equipment against lightning strikes. The surge protector power strip can be fixed on the rack, workbench, or wall in the equipment room by using cable ties and screws. AC power enters the equipment through the surge protector power strip.

Figure 6-4 Installing an AC Power Lightning Arrester

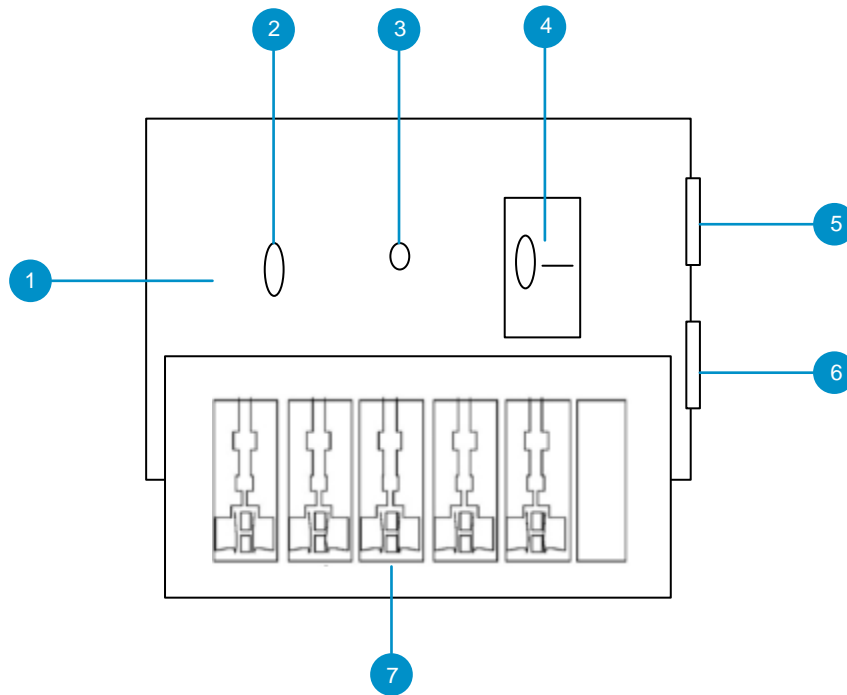

No.	Description
1	Installed electronic circuit board
2	Normally running indicator: When the indicator is green, the circuit is working properly. Otherwise, the protective circuit is damaged.
3	Grounding and polarity detection indicator: If the indicator is red, cable connection is incorrect (the ground cable is not connected, or the N and L lines are reversely connected). Check your power supply line.
4	Power switch
5	IEC standard socket, which is connected to the power supply in the equipment room through the power cable
6	Overload auto-protector, which can be reset manually
7	Multi-purpose sockets (connected to the power supply of the switch)

Note

The lightning arrester is not delivered with the equipment. Please purchase it based on actual requirements.

Precautions:

- Make sure that the PE terminal of the power arrester is well grounded.
- After the AC power plug of the equipment is connected to the socket of the power arrester (lightning

resistance socket), the surge protection function is implemented only if the RUN indicator is green and the ALARM indicator is OFF.

- If the indicator on the power arrester is red, check whether it is caused by poor grounding connection or by the reversed connection of the Null and Live lines. The detection method is as follows: Use a multimeter to measure the polarity of the power socket for the arrester when the indicator is red. If the N line is on the left and the L line is on the right (facing the socket), the arrester's PE terminal is not grounded. If not, the polarity of the arrester power cord should be reversed. In this case, you should open the power arrester and rectify the polarity of the connection. If the indicator is still red, the arrester's PE terminal is not grounded.

6.3.2 Installing an Ethernet Port Lightning Arrester

Connect an Ethernet port arrester to the equipment to prevent the damage by lightning before connecting an outdoor network cable to the device.

Tools: Phillips screwdrivers or flat-head screwdriver, multimeter, and diagonal pliers

Procedure:

- (1) Tear one side of the protective paper for the double-sided adhesive tape and paste the tape to the enclosure of the Ethernet port arrester.
- (2) Tear the other side of the protective paper for the double-sided adhesive tape and paste the Ethernet port arrester to the enclosure. The paste position for the Ethernet port arrester should be as close to the grounding terminal of the equipment as possible.
- (3) According to the distance between the equipment grounding terminal and the Ethernet port arrester, cut the grounding cable for the Ethernet port arrester and firmly crimp the grounding cable to the grounding terminal of the equipment.
- (4) Use a multimeter to check whether the grounding cable for the arrester is in good contact with the grounding terminal and the enclosure of the equipment.
- (5) Connect the arrester by using an adapter cable (note that the external network cable is connected to the IN end, while the adapter cable connected to the equipment is connected to the OUT end) and check whether the service module LED is normal.
- (6) Use a nylon cable tie to bind the power cords.

Figure 6-5 Installing an Ethernet Port Lightning Arrester

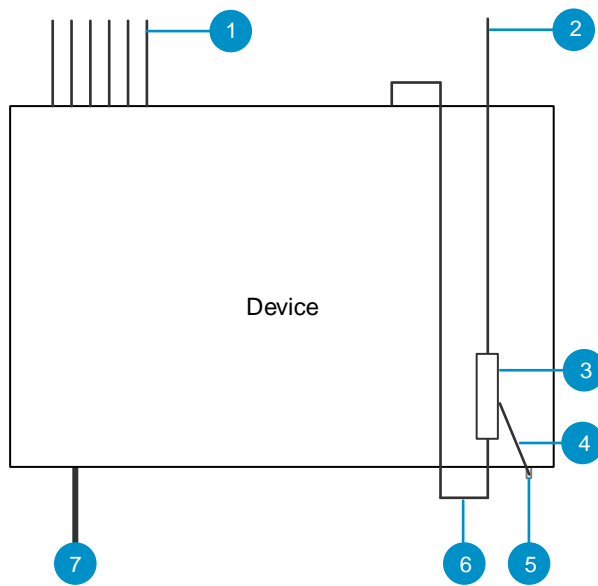

No.	Description
1	Ethernet cable for indoor connection
2	Ethernet cable connected to the outdoor
3	RJ45 port arrester (pasted on the enclosure)
4	Ground cable of the arrester
5	Grounding lug of the equipment
6	RJ45 port adapter cable
7	Power input

Note

- The Ethernet port arrester is only for Ethernet ports with an RJ45 connector.
- The Ethernet port arrester is not delivered with the equipment. Please purchase it based on actual requirements. The Ethernet port arrester user manual contains technical parameters and maintenance and installation instructions for the Ethernet port arrester. Carefully read this manual before installation.

Pay attention to the following situations during the installation to avoid influencing the performance of the Ethernet port arrester:

- Reversed installation direction of the arrester. Connect the external network cable to the “IN” end and connect the Ethernet port of the equipment to the “OUT” end.
- Poor grounding of the arrester. The grounding cable of the arrester should be as short as possible to ensure that it is in good contact with the grounding terminal of the equipment. Use a multimeter to confirm the contact condition after grounding.

- Incomplete arrester installation. If there is more than one port connected to external power cords, arresters need to be installed on all connection ports for the purpose of surge protection.