

R4P**CN**

- (2) Side Channel Assemblies
- (2) Base Angles
- (2) Top Brackets
- (1) Hardware Kit
 - (25) 12-24 Cage Nuts
 - (25) 12-24 x.5" Screws
 - (16) Paint Piercing Washers
 - (16) 3/8 x 1" Bolts
 - (1) Tube of Anti-Oxidizing Gel

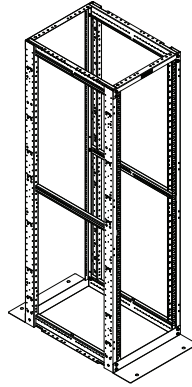

R4P****

- (2) Side Channel Assemblies
- (2) Base Angles
- (2) Top Bracket
- (1) Hardware Kit
 - (25) 12-24 x.5" Screws
 - (16) Paint Piercing Washers
 - (16) 3/8 x 1" Bolts
 - (1) Tube of Anti-Oxidizing Gel

Step 1

Lay one side assembly on the floor or on a pair of sturdy saw horses. Apply antioxidant paste to painted surfaces that the 3/8" paint piercing washers will come in contact with. Install base angles and top brackets using (8) 3/8" bolts and paint piercing washers.

DO NOT TIGHTEN.

Note: The base angles are assembled on the bottom of the rack and the top angles are assembled at the top of the rack. A diamond on the outer face of each post indicates the bottom of the rack. See closeup in Step 2.

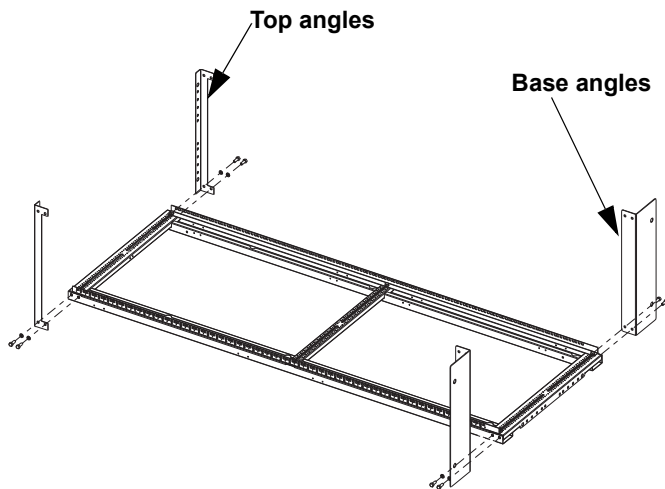

NOTE: If using caster bracket kit (RCSTR). Reference CM450.

Fixed Caster and Bracket Assembly

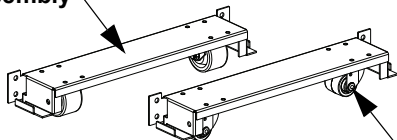

Swivel Caster and Bracket Assembly

Step 2

Place remaining side assembly as shown. Apply antioxidant paste to painted surfaces that the 3/8" paint piercing washers will come in contact with. Assemble to base angles using 3/8" bolts and paint piercing washers. One of each per side.

DO NOT TIGHTEN.

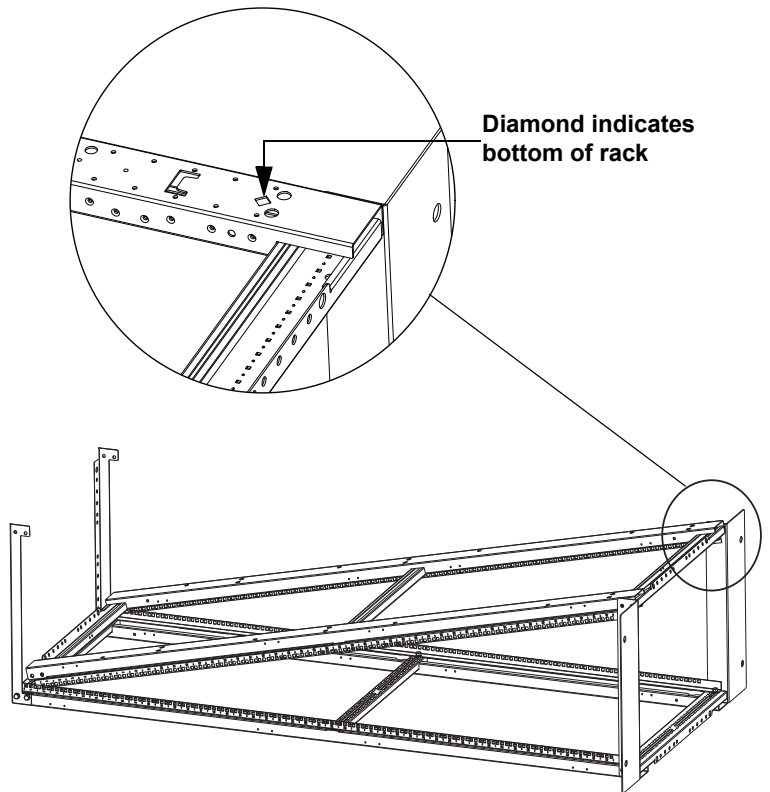

Diamond indicates bottom of rack

Step 3

Hinging side assembly on the two fasteners affixed in Step 2, rotate Side assembly upwards to align mounting holes in the two top brackets. Install remaining (6) 3/8" Bolts and paint piercing washers in the locations shown below. Stand the rack upright. Verify #12-24 tapped holes or Cage nuts are EIA spaced at 18.31". Square the rack vertically by measuring the distance from A to D, and B to C shown in 3.2. The difference in distance from A to D, and B to C should be no greater than 1/8". Square the rack horizontally by measuring the distance from E to H, and F to G shown in 3.3. The difference in distance from E to H, and F to G should be no greater than 1/8". **Completely tighten all bolts to at least 14 ft.-lbs (19.0 N-m)**

3.1

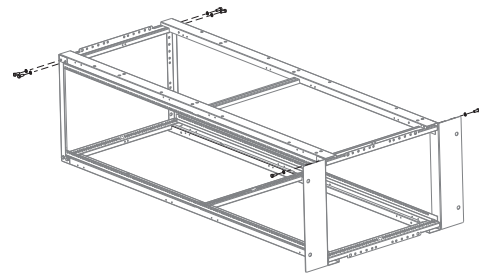

3.2

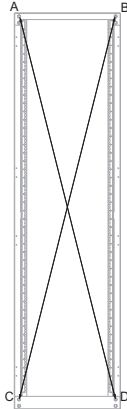

3.3

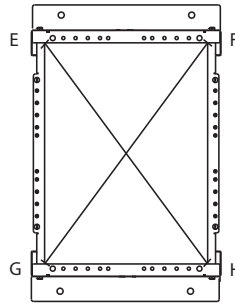

Grounding

Grounding Locations

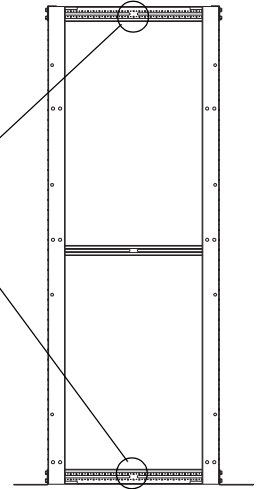

Two hole ground lug attachment located on the top and bottom rails of the side channel assembly at the locations shown. Remove masking before installing.

Location Guide

Mount rack to floor using the location guide below for mounting hole and overall size information.

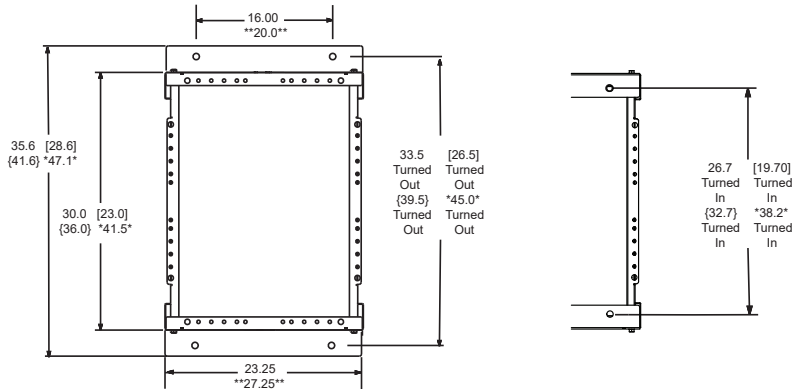

All dimensions are in inches.

- x.xx are dimensions for 30" deep 4 post racks
- [x.xx] are dimensions for 23" deep 4 post racks
- {x.xx} are dimensions for 36" deep 4 post racks
- *x.xx* are dimensions for 42" deep 4 post racks
- **x.xx** are dimensions for 23" wide 4 post racks

Note: Floor mounting bolts must be used in all applications in order to provide maximum rigidity, load bearing capacity and safety. The maximum weight load is 2500 pounds. The rack is designed for heavier equipment to be mounted near the bottom and supported from front to back. Shelves (sold separately) that mount on both the front and rear of the rack may also be installed to support equipment. Manufacturers often provide a shelf (or cradle) to support their specific equipment. In cases where the manufacturer doesn't provide a cradle, please contact Panduit engineering prior to installation for possible alternative mounting methods.

Adjustable EIA Mounting Rails

All 4 rails are fully adjustable. To set depth loosen (3) 5/16"-18 X 3/4" Mounting bolts and slide to desired position. **Re-tighten to 20 foot pounds to engage washers.**

Panduit recommends putting the front rails 1" back for optimal thermal and cable management. Front rails are to be recessed less than 1.5" to be compatible with newer thermal ducts.

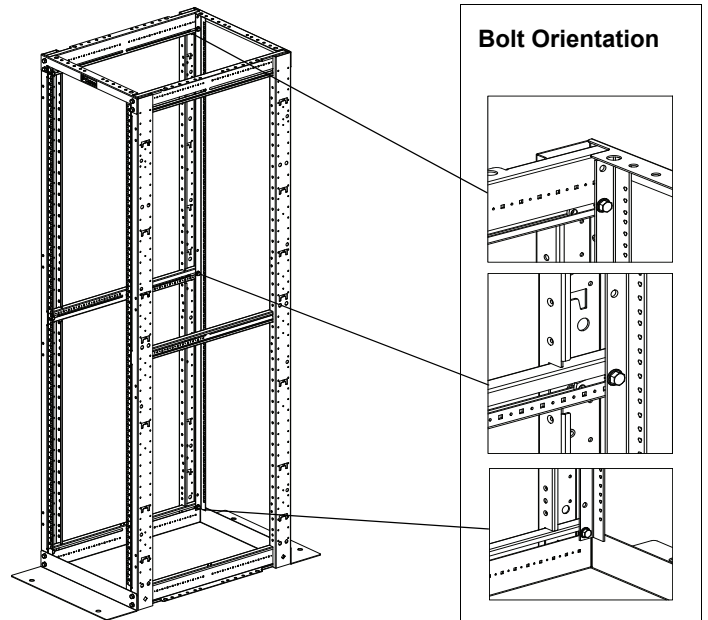

Flippable EIA Mounting Rails

The rack is shipped with rails in a numbers-up orientation. The rails can be flipped to read in a numbers-down orientation by moving 1 right rail and 1 left rail in tandem. Remove (3) 5/16"-18 X 3/4" Mounting Bolts on each rail. Then flip **right** rail so that numbering reads down and bolt to **left** side of assembly using bolt orientation shown. Then flip **left** rail so that numbering reads down and bolt to **right** side of assembly using bolt orientation shown.

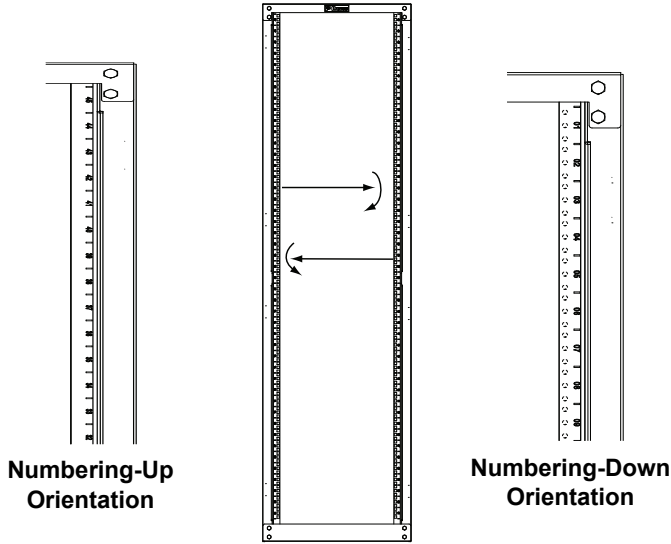

Use J-Bolt mounting holes for securing ladder rack to the 4-post rack.

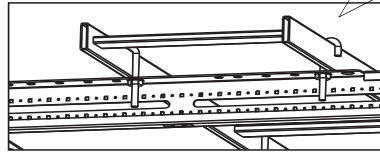

J-Bolts up to 3/8" in diameter may also be installed directly to the top angle without interference with the top mounting RU space.

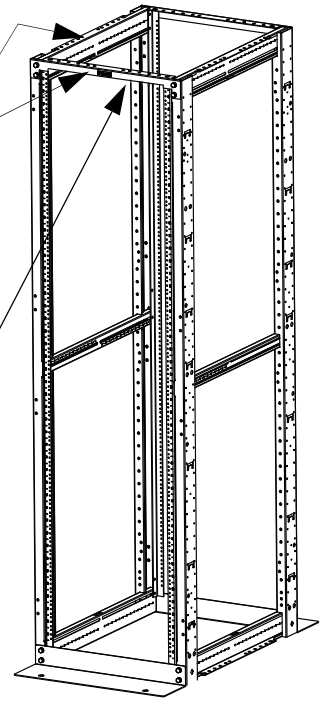

PR2VWF/PE2VWF

1. Align waterfall slots around the backbone part of the manager as shown.
2. Align holes in waterfall with holes in rack.
3. Fasten components together using
 - (2) M6 x 12mm screws &
 - (2) M6 serrated nuts.

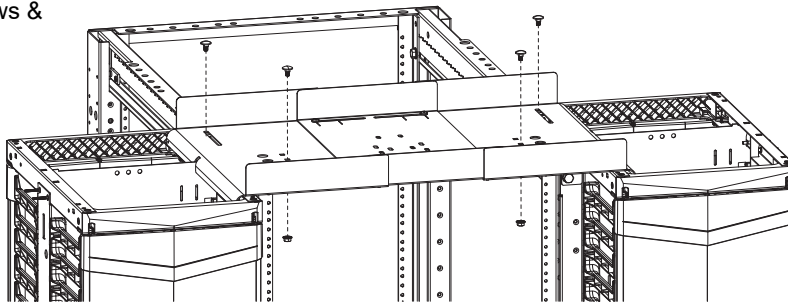

CVPPB- Zero RU Bracket- to mount 1RU EIA 19" copper and fiber patch panels to the side of rack posts.

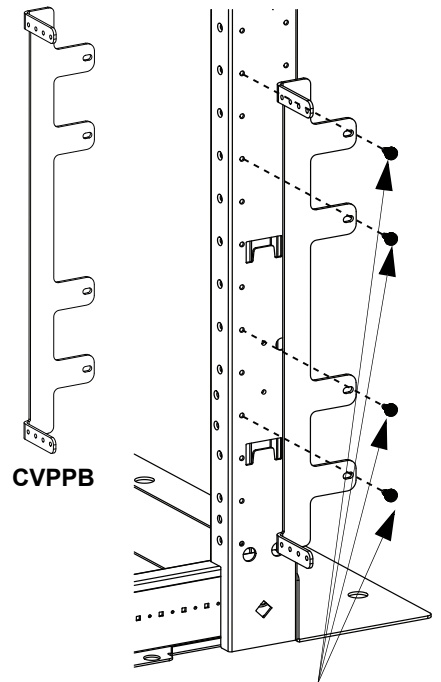

CVPPB

Secure to desired hole location using #12-24 screws

Side of post installation

- RSHLF- Shelf for 30" Deep rack
- RSHLF23- Shelf for 23" Deep rack
- RSHLF36- Shelf for 36" Deep rack

Note: Shelf load rating is 275 lbs. when rails are spaced a minimum of half the shelf depth.

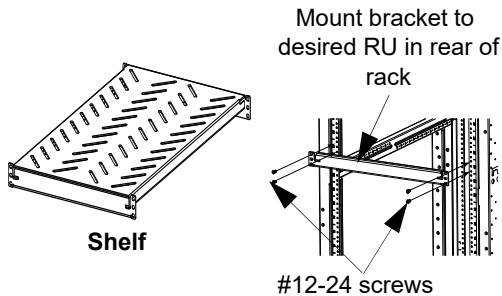

Slide shelf into slots in rear mounting bracket

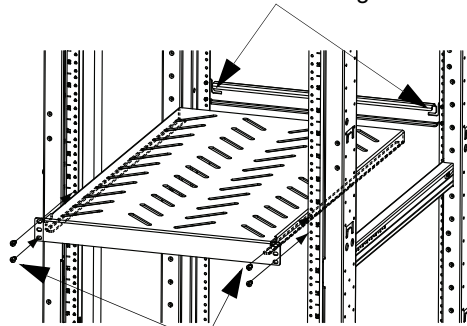

Secure with (4) #12-24 screws

Note: Shelf is designed to support large networking equipment in combination with supplied equipment mounting flanges.

Large equipment installation- Install mounting cradle (included with equipment.) See Best Practices below.

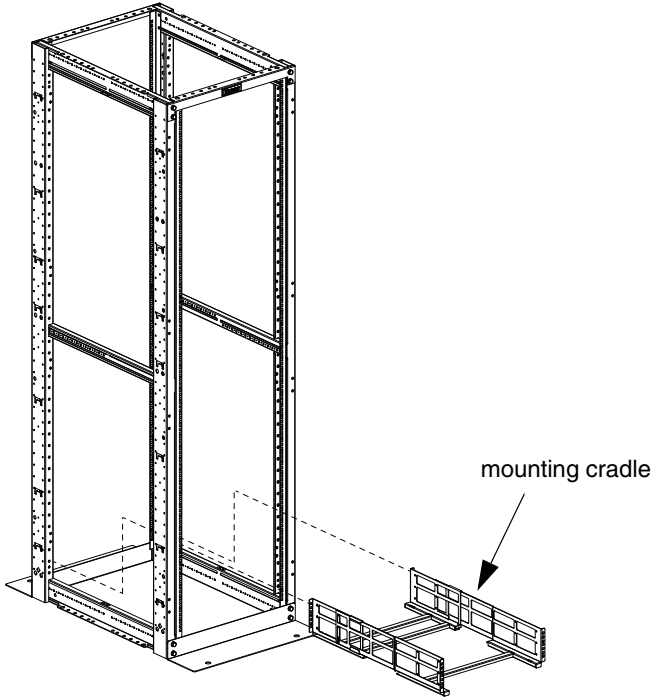

Large equipment installation- Install equipment. When installing securing hardware, install bottom, top, middle screws and tighten before installing remaining screws. See Best Practices below.

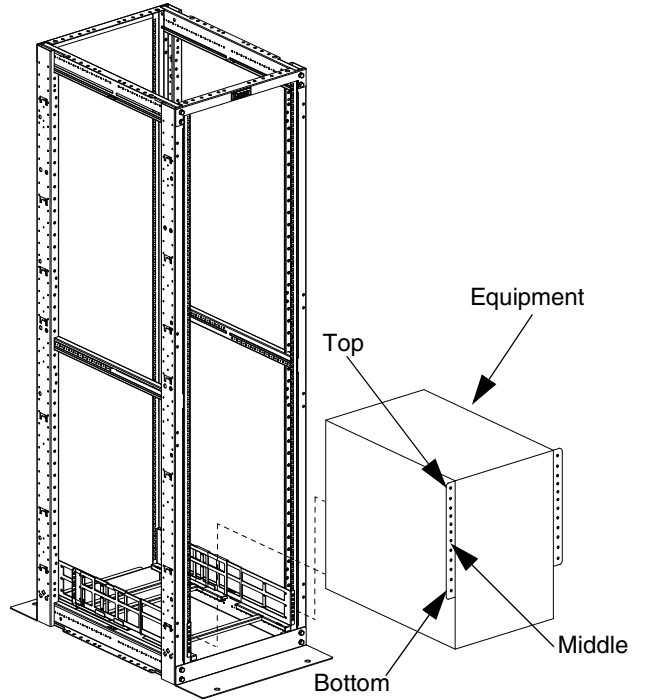

LARGE EQUIPMENT INSTALLATION BEST PRACTICES

Install the equipment at the lowest possible RU on the rack for stability. If there are other devices in the rack, install the heaviest chassis below the lighter chassis.

Refer to equipment installation documents for specific installation requirements.

Only trained and qualified personnel should be allowed to install, replace, or service equipment.

CVPDUB- Pair of Brackets for Vertical POU Button Mounting to the side of the rack post.

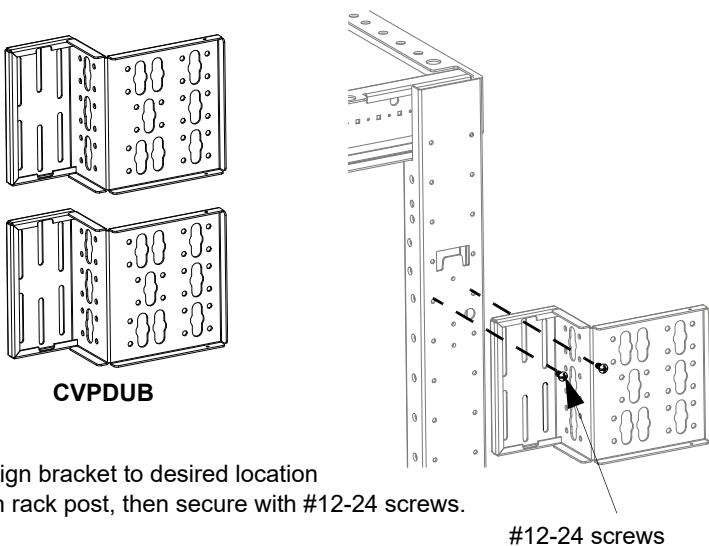

Align bracket to desired location on rack post, then secure with #12-24 screws.

For instructions in Local Languages and Technical Support:

www.panduit.com/resources/install_maintain.asp



www.panduit.com

E-mail: techsupport@panduit.com
 Fax: (866)405-6654