

# THORSMAN®

by *thorsmex*  
group

## PROTECTOR DE ESQUINAS 6 FT

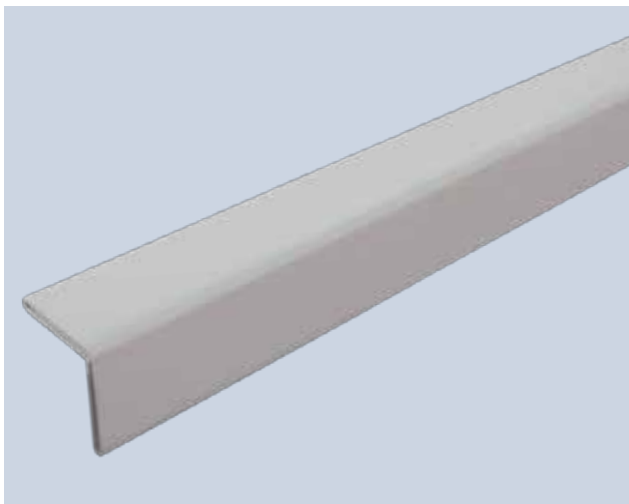

## LÍNEA DE CANALIZACIÓN



## PROTECTOR DE ESQUINAS 6 FT

### Descripción

- Ideal para proteger las esquinas de paredes de muros falsos en zonas de alto tráfico de personas, automóviles, máquinas, equipos, entre otros que dañen las esquinas de los muros.

### Propiedades del Producto

- Color: Blanco
- Alta rigidez dielectrica
- Resistente a la humedad y atmosfera corrosiva
- Temperatura de trabajo  $-5^{\circ}\text{C}$  a  $+65^{\circ}\text{C}$
- Presentación 6 FT(1.83 m. ) y Pegathor de 70 g

### Solución/Mercado



Hogar



Oficina



Industria

### Materiales

- Pvc Rígido, Autoextinguible



ISO 9001-2015

**THORMEX, S.A. DE C.V.**

Bld. Manuel Ávila Camacho 2900-701, Fracc. Los Pirules, Tlalnepantla,  
Edo. de México, C.P.54040 • Tel: (01-55) 5379-67-47 Área comercial:  
EXT 104, 105, 119, 120 y 128 • info@thorsmex.mx

[www.thorsmex.mx](http://www.thorsmex.mx)



PROTECTOR DE ESQUINAS

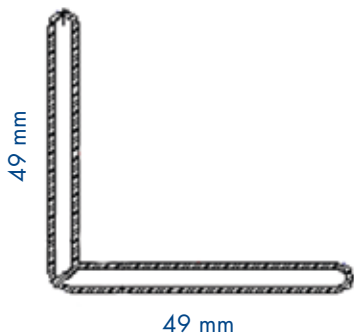

Descripción	Código	Código de Barras	Presentación	Color	Dimensiones	Peso
PROTECTOR DE ESQUINAS 6 FT C-PEGAMENTO	21000-00001	7501509900431	Tramo de 6 ft (1.83 m.) y PEGATHOR DE 70 g	Blanco	H 49 mm x L 1830 mm x W 49 mm	Peso por metro lineal 246.6 g

APLICACIÓN



ISO 9001-2015