



PX3 Series

Bluetooth® Differential Pressure / Air Velocity Transducer

Product Overview

The PX3 transducer can measure either air pressure or velocity with the flip of a switch. The PX3 is available in three installation configurations: duct, panel or universal. Duct and panel models have two pressure and velocity ranges: 0-1 in. WC / 0-3,000 ft/min or 1-10 in. WC / 3,000-6,000 ft/min with four field-selectable sub-ranges. The universal model comes in one pressure/velocity range: 0-10 in. WC / 0-7,000 ft/min with seven field-selectable sub-ranges for pressure and eight for velocity. All variants are available with and without display. The PX3 has an IP65/NEMA 4 environmental rating and a 5-year limited warranty.

The Veris Sensors App provides the ability to connect to a device and configure a variety of field-selectable parameters remotely from a smartphone via Bluetooth technology. The app allows users to create and store commonly used parameters that will reduce commissioning time and provide assurance that all parameters are properly configured with no call backs. The app can also create a trend log while connected, providing important data for troubleshooting purposes. iOS® users can download the app through the [iOS App Store](#) on their smart device. Android users can download the app through the [Google Play™ store](#). For instructions on downloading and operating the app, see the [Veris Sensors App User's Guide](#) and [Veris Sensors App Quick Start Guide](#) available on the Veris website.

Product Identification

	Enclosure	Local Display	NIST Certificate*	Range	Wireless Technology
PX3	<input type="checkbox"/> D = Duct <input type="checkbox"/> P = Panel	<input type="checkbox"/> L = LCD Display <input type="checkbox"/> X = No Display	<input type="checkbox"/> N = NIST <input type="checkbox"/> X = None	01 = Pressure: 0 to 1 in. WC / 0 to 250 Pa Velocity: 0 to 3,000 ft/min / 0 to 15 m/s 02 = Pressure: 1 to 10 in. WC / 250 to 2,500 Pa Velocity: 3,000 to 6,000 ft/min / 15 to 30 m/s	<input type="checkbox"/> Blank = Wireless technology enabled mode
		*8-point calibration			
PX3U	<input type="checkbox"/> L = LCD Display <input type="checkbox"/> X = No Display	<input type="checkbox"/> N = NIST* <input type="checkbox"/> X = None	05 = Pressure: 0 to 10 in. WC / 0 to 2500 Pa Velocity: 0 to 7000 ft/min / 0 to 35 m/s	<input type="checkbox"/> Blank = Wireless technology enabled mode	
		*16-point calibration			

This product is intended for use in HVAC and building environmental control applications. It is not intended for direct medical monitoring of patients. Read and understand these instructions before installing this product. The installer is responsible for all applicable codes. If this product is used in a manner not specified by the manufacturer, the protection provided by the product may be impaired. No responsibility is assumed by the manufacturer for any consequences arising out of the use of this material.

Dimensions

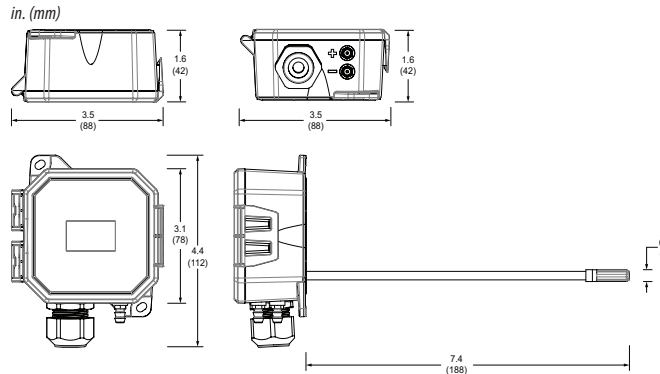

Specifications

Media Compatibility	Dry air or inert gas
Input Power	Three-wire Volt mode: 24 Vac or 12-30 Vdc* Two-wire mA mode: 12-30 Vdc*
Output Power	Field-selectable: 2-wire, loop-powered 4-20 mA Minimum input voltage for 4 to 20 mA operation: 250 Ω loop = 12 Vdc; 500 Ω loop = 19 Vdc (DC only, clipped and capped), 24 Vac/dc or 3-wire 0-5V/0-10V Minimum load resistance for Volt operation: 5 kΩ
01 Pressure Range	Pressure Mode
	Velocity Mode
02 Pressure Range	Pressure Mode
	Velocity Mode
05 Pressure Range	Pressure Mode
	Velocity Mode
Response Time	Standard: T95 in 20 sec, Fast: T95 in 2 sec, DIP switch selectable
Mode	Unidirectional or bidirectional, DIP switch selectable
Display (Option)	Pressure mode: Signed 3-1/2 digit LCD, indicates pressure, overrange indicator Velocity mode: Signed 4-1/2 digit LCD, indicates velocity, overrange indicator
Proof Pressure	3 psid (20, 600 Pa)
Burst Pressure	5 psid (34, 500 Pa)
Pressure Mode Accuracy	±1% FS (combined linearity and hysteresis)
Velocity Mode Accuracy	±90 ft/min (±0.45 m/s) plus 5% of measured value**
Temperature Effect	1 in. WC (250 Pa) models: 0.05%/°C; 10 in. WC (2,500 Pa) models: 0.01%/°C (Relative to 25 °C) 0 to 50 °C (32 to 122 °F)

Specifications (cont.)

Zero Drift (1-year)	1 in. WC (250 Pa) models: 2.5% FS typ.; 10 in. WC (2,500 Pa) models: 0.25% FS typ.
Zero Adjust	Pushbutton auto-zero and digital input (2-pos terminal block)
Operating Environment	-20 to 60 °C (-4 to 140 °F)***
Altitude of Operation	0 to 3000 m
Pollution Degree	2
Humidity Range	100% RH, non-condensing
Mounting Location	For indoor or outdoor use (display will not function below 0 °C (32 °F))
Fittings	Brass barb; 0.24" (6.1 mm) o.d.
Suggested Cable	Shielded: Belden #9939 (22 AWG) 3-wire multi-conductor (or similar) Belden #9940 (22 AWG) 4-wire multi-conductor (or similar) Belden #9939 (22 AWG) 5-wire multi-conductor (or similar) Unshielded: Belden #8443 (22 AWG) 3-wire multi-conductor (or similar) Belden #8444 (22 AWG) 4-wire multi-conductor (or similar) Belden #8445 (22 AWG) 5-wire multi-conductor (or similar)
Bluetooth Frequency Range	2.402 to 2.480 GHz (Bluetooth version 4.2), enabled by DIP switch, enabled by DIP switch
Maximum Output Power	0 dBm
Limited Warranty	5 years
Environmental Rating	IP65, NEMA 4
Flammability Rating	UL 94 5VA fire retardant ABS, plenum rated

EMC Conformance: EN 61000-6-3 and A1, Class B, EN 61000-6-1, EN61326-1 and EN61326-2-3.
* Class 2/II power source.
** For measured values between 200 and 7000 ft/min (1 and 35 m/s).
*** Display will not function below 0 °C (32 °F).

Installation, Wiring & Configuration

1. Plan the installation. Panel or duct mount?

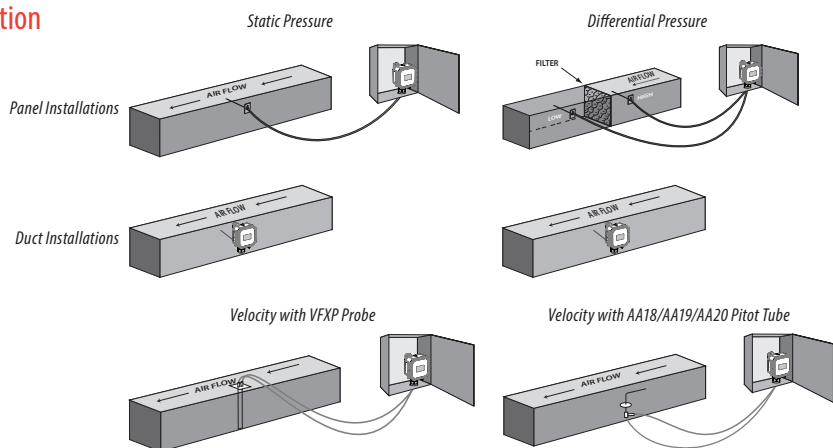

For velocity applications, use the VFXP Series air velocity/measurement probe or AA18, AA19 or AA20 velocity pitot tubes. For use with the PX3P (panel) and PX3U (universal) models in Velocity mode only. Sold separately.

Installation, Wiring & Configuration (cont.)

- For duct mount applications, thread the probe into the back of the device housing, as shown in the dimensional drawing. Configure the internal tubing for the selected installation method as described below.
- Duct mount tubing configuration:
 - Connect sensor port A to the rear brass barb marked as "-" on the underside of the device housing.
 - Connect sensor port B to the probe in the back of the device housing.

Panel mount tubing configuration:

- Connect sensor port A to the rear brass barb marked as "-" on the underside of the device housing.
- Connect sensor port B to the front brass barb marked as "+" on the underside of the device housing.

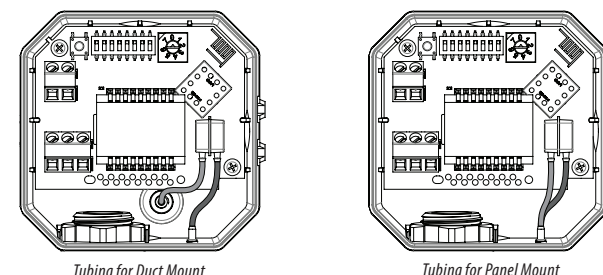

- Mount the transducer (see the screw hole diagram below).

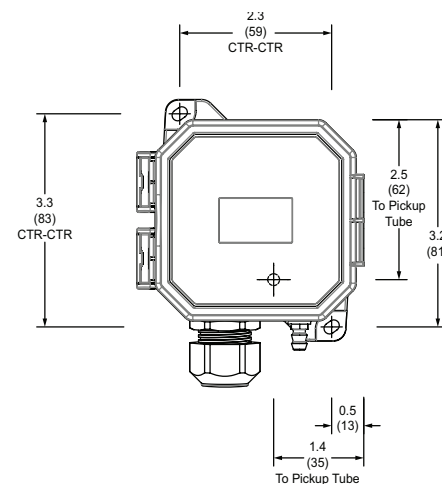

Installation, Wiring & Configuration (cont.)

- For applications using conduit, remove the cable gland nut on the bottom of the unit. Thread a standard 1/2-inch NPT female threaded coupler onto the body of the cable gland. Connect the opposite end of the coupler to the conduit.

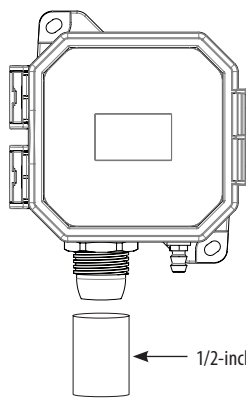

- Set DIP switches to desired settings.*

DIP Switch 1: Scale ON = Pascal (m/s) OFF = in. WC (ft/min)	DIP Switch 5: Output ON = 4-20 mA OFF = Voltage
DIP Switch 2: Mode ON = Velocity OFF = Pressure	DIP Switch 6: Volt Scale ON = 0-5 Vdc OFF = 0-10 Vdc
DIP Switch 3: Direction** ON = Unidirectional OFF = Bidirectional	DIP Switch 7: Wireless ON = Disabled OFF = Enabled
DIP Switch 4: Response ON = Slow OFF = Fast	DIP Switch 8: Unused

*DIP switches are all set to OFF by the factory.
**Velocity mode is unidirectional regardless of DIP switch setting.

DIP Switch Settings

	Scale	Mode	Direction	Response	Output	Volt Scale	Wireless	Unused
ON	Pascal/MPS	Velocity	Uni	Slow	mA	5V	Disabled	Unused
OFF	in. WC/FPM	Pressure	Bi	Fast	Volt	10V	Enabled	Unused
	1	2	3	4	5	6	7	8

- Set rotary switch to the desired setting. Align the arrow (not the slot) on the rotary switch to the desired full-scale range. LCD models momentarily indicate the selected range.

Installation, Wiring & Configuration (cont.)

Rotary Switch Settings

Range 01 Model, Field Selectable (WC / ft/min or Pa / m/s)

	(P) Pressure Mode	(V) Velocity Mode
0	0 to 0.1 in. WC	0 0 to 500 ft/min
1	0 to 0.25 in. WC	1 0 to 1,000 ft/min
2	0 to 0.5 in. WC	2 0 to 2,000 ft/min
3	0 to 1 in. WC	3 0 to 3,000 ft/min
4	0 to 0.1 in. WC	4 0 to 500 ft/min
5	0 to 0.25 in. WC	5 0 to 1,000 ft/min
6	0 to 0.5 in. WC	6 0 to 2,000 ft/min
7	0 to 1 in. WC	7 0 to 3,000 ft/min

	(P) Pressure Mode	(V) Velocity Mode
0	0 to 25 Pa	0 0 to 2.5 m/s
1	0 to 50 Pa	1 0 to 5 m/s
2	0 to 100 Pa	2 0 to 10 m/s
3	0 to 250 Pa	3 0 to 15 m/s
4	0 to 25 Pa	4 0 to 2.5 m/s
5	0 to 50 Pa	5 0 to 5 m/s
6	0 to 100 Pa	6 0 to 10 m/s
7	0 to 250 Pa	7 0 to 15 m/s

Range 02 Model, Field Selectable (WC / ft/min or Pa / m/s)

	(P) Pressure Mode	(V) Velocity Mode
0	0 to 1 in. WC	0 0 to 3,000 ft/min
1	0 to 2.5 in. WC	1 0 to 4,000 ft/min
2	0 to 5 in. WC	2 0 to 5,000 ft/min
3	0 to 10 in. WC	3 0 to 6,000 ft/min
4	0 to 1 in. WC	4 0 to 3,000 ft/min
5	0 to 2.5 in. WC	5 0 to 4,000 ft/min
6	0 to 5 in. WC	6 0 to 5,000 ft/min
7	0 to 10 in. WC	7 0 to 6,000 ft/min

	(P) Pressure Mode	(V) Velocity Mode
0	0 to 250 Pa	0 0 to 15 m/s
1	0 to 500 Pa	1 0 to 20 m/s
2	0 to 1,000 Pa	2 0 to 25 m/s
3	0 to 2,500 Pa	3 0 to 30 m/s
4	0 to 250 Pa	4 0 to 15 m/s
5	0 to 500 Pa	5 0 to 20 m/s
6	0 to 1,000 Pa	6 0 to 25 m/s
7	0 to 2,500 Pa	7 0 to 30 m/s

Installation, Wiring & Configuration (cont.)

Rotary Switch Settings (cont.)

Range 05 Model, Field Selectable (P) Pressure or (V) Velocity Mode, Field Selectable (WC / ft/min or Pa / m/s)

	(P) Pressure Mode	(V) Velocity Mode
0	0 to 0.1 in. WC	0 0 to 500 ft/min
1	0 to 0.25 in. WC	1 0 to 1,000 ft/min
2	0 to 0.5 in. WC	2 0 to 2,000 ft/min
3	0 to 1 in. WC	3 0 to 3,000 ft/min
4	0 to 2.5 in. WC	4 0 to 4,000 ft/min
5	0 to 5 in. WC	5 0 to 5,000 ft/min
6	0 to 10 in. WC	6 0 to 6,000 ft/min
7	0 to 10 in. WC	7 0 to 7,000 ft/min

	(P) Pressure Mode	(V) Velocity Mode
0	0 to 25 Pa	0 0 to 2.5 m/s
1	0 to 50 Pa	1 0 to 5 m/s
2	0 to 100 Pa	2 0 to 10 m/s
3	0 to 250 Pa	3 0 to 15 m/s
4	0 to 500 Pa	4 0 to 20 m/s
5	0 to 1,000 Pa	5 0 to 25 m/s
6	0 to 2,500 Pa	6 0 to 30 m/s
7	0 to 2,500 Pa	7 0 to 35 m/s

- Connect the transmitter to the control system and power supply as indicated below. Optional: Connect the ZERO terminals to the digital output (contact closure) of the control system.

2-wire, 4-20 mA Current Loop Output

3-wire, 0-5 V/0-10 V Voltage Output

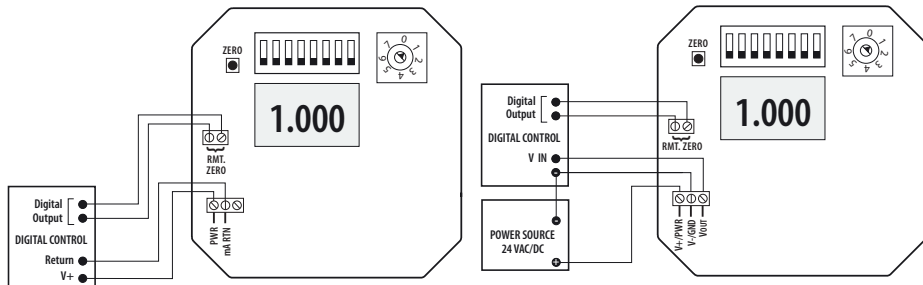

Installation, Wiring & Configuration (cont.)

- Wait five seconds, then press and hold the ZERO pushbutton for two seconds or provide contact closure on the AUX ZERO terminal. This will reset the output and display to zero pressure. For best accuracy, press the ZERO button while both ports are open to atmospheric pressure. To protect the unit from accidental zero, this feature is enabled only when the detected pressure is within about 0.5 in. WC (125 Pa) of factory calibration.

- Connect desired external tubing to the PX3.

Operation

PX3 Series devices employ high performance sensors and sophisticated temperature compensation circuitry. The sensor achieves its best accuracy after an initial warm-up period. During the first few minutes of operation, readings at zero pressure and the lowest pressure ranges may appear erroneous. Following this initial warm-up period, the PX3 device maintains its specified accuracy and stability.

The LCD momentarily indicates range 'SET' when a selection is made. Pressure is normally indicated on the display. Units are in inches water column (in. WC), Pascals (Pa) or kilopascals (kPa) as indicated on the display. The display shows 'OVR' when the pressure is over range.

China RoHS Compliance Information

Environment-Friendly Use Period (EFUP) Table

部件名称	有害物质 - Hazardous Substances					
Part Name	铅 (Pb)	汞 (Hg)	镉 (Cd)	六价铬 (Cr (VI))	多溴联苯 (PBB)	多溴二苯醚 (PBDE)
电子件 Electronic	X	O	O	O	O	O

本表格依据SJ/T11364的规定编制。
O: 表示该有害物质在该部件所有均质材料中的含量均在GB/T 26572规定的限量要求以下。
X: 表示该有害物质至少在该部件的某一均质材料中的含量超出GB/T 26572规定的限量要求。(企业可在此处, 根据实际情况对上表中打 'X' 的技术原因进行进一步说明。)

This table is made according to SJ/T 11364.
O: indicates that the concentration of hazardous substance in all of the homogeneous materials for this part is below the limit as stipulated in GB/T 26572.
X: indicates that concentration of hazardous substance in at least one of the homogeneous materials used for this part is above the limit as stipulated in GB/T 26572.

Z000057-08

This device complies with part 15 of the FCC Rules. Operation is subject to the following two conditions: (1) This device may not cause harmful interference, and (2) this device must accept any interference received, including interference that may cause undesired operation.

Changes or modifications not expressly approved by the party responsible for compliance could void the user's authority to operate the equipment.

This device complies with Industry Canada license-exempt RSS standard(s). Operation is subject to the following two conditions: (1) this device may not cause interference, and (2) this device must accept any interference, including interference that may cause undesired operation of the device.

Cet appareil est conforme aux normes d'exemption de licence RSS d'Industry Canada. Son fonctionnement est soumis aux deux conditions suivantes: (1) cet appareil ne doit pas causer d'interférence et (2) cet appareil doit accepter toute interférence, notamment les interférences qui peuvent affecter son fonctionnement.