

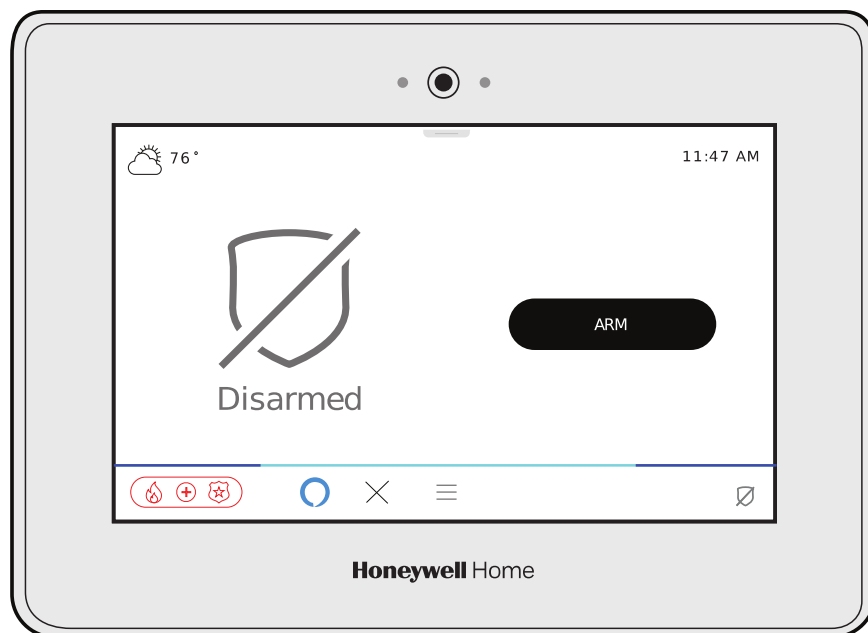

PROA7/PROA7PLUS Series

Installation and Setup Guide



RECOMMENDATIONS FOR PROPER PROTECTION

The Following Recommendations for the location of fire and burglary detection devices help provide proper coverage for the protected premises.

Recommendations for Smoke and Heat Detectors

With regard to the number and placement of smoke/heat detectors, we subscribe to the recommendations contained in the National Fire Protection Association's (NFPA) Standard #72 noted below.

- Early warning fire detection is best achieved by the installation of fire detection equipment in all rooms and areas of the household as follows: For minimum protection a smoke detector should be installed outside of each separate sleeping area, and on each additional floor of a multi-floor family living unit, including basements. The installation of smoke detectors in kitchens, attics (finished or unfinished), or in garages is not normally recommended.
- For additional protection the NFPA recommends that you install heat or smoke detectors in the living room, dining room, bedroom(s), kitchen, hallway(s), attic, furnace room, utility and storage rooms, basements and attached garages.

In addition, we recommend the following:

- Install a smoke detector inside every bedroom where a smoker sleeps.
- Install a smoke detector inside every bedroom where someone sleeps with the door partly or completely closed. Smoke could be blocked by the closed door. Also, an alarm in the hallway outside may not wake up the sleeper if the door is closed.
- Install a smoke detector inside bedrooms where electrical appliances (such as portable heaters, air conditioners or humidifiers) are used.
- Install a smoke detector at both ends of a hallway if the hallway is more than 40 feet (12 meters) long.
- Install smoke detectors in any room where an alarm control is located, or in any room where alarm control connections to an AC source or phone lines are made. If detectors are not so located, a fire within the room could prevent the control from reporting a fire or an intrusion.

THIS CONTROL COMPLIES WITH NFPA REQUIREMENTS FOR TEMPORAL PULSE SOUNDING OF FIRE NOTIFICATION APPLIANCES.

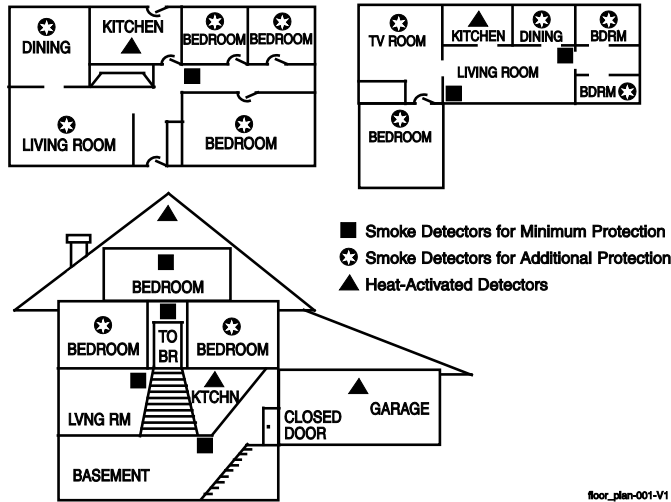

Recommendations for Proper Intrusion Protection

- For proper intrusion coverage, sensors should be located at every possible point of entry to a home or premises. This would include any skylights that may be present, and the upper windows in a multi-level building.
- In addition, we recommend that radio backup be used in a security system. This ensures that alarm signals can be sent to the alarm monitoring station in the event that the communications are out of order (if connected to an alarm monitoring station).

This Honeywell Home security system is designed for use with devices manufactured or approved by Resideo Technologies, Inc., through its subsidiary Ademco Inc. ("Resideo"). Your security system is not designed for use with any device that may be attached to your security system's touchpad or other communicating bus if Resideo has not approved such device for use with your security system. Use of any such unauthorized device may cause damage or compromise the performance of your security system and affect the validity of your Resideo limited warranty. When you purchase devices that have been manufactured or approved by Resideo you acquire the assurance that these devices have been thoroughly tested to ensure optimum performance when used with your security system.

Table of Contents

System Features	1
Proper Installation Steps	3
Creating a Customers Account	4
Customer Information	4
Security	4
Total Connect 2.0	5
Connect the Control Panel	6
Backup Battery Installation	6
Installing the Rechargeable Backup Battery	6
System Low Battery Messages	6
Replacing the Rechargeable Backup Battery	7
Wall Mounting.....	7
Desktop Mounting.....	8
Communication Modules	9
Installing the PROLTE Series Cellular Communications Module	9
Installing the PROWIFIZW Wi-Fi and Z-Wave Communications Module	10
Installing the PROTAKEOVER Wireless Converter Module	11
AC Power	12
Initial Configuration	13
Configure Wireless Devices	14
Sensors	14
Range	14
Frequency Agility	14
One-Go-All-Go.....	14
Smoke / CO Maintenance	14
Transmitter Supervision.....	14
Transmitter Battery Life	15
Testing Signal Strength	15
Keypad / Touchscreen Setup	15
PROSIXLCDKP Wireless Keypad	15
PROWLTOUCH Wireless Touchscreen	16
Connecting the PROWLTOUCH to Wi-Fi	17
Configuring Programming	19
Touchscreen Display	19
Navigation Keys/Home Screen.....	20
Master User Options.....	21
Programming	22
Setting up the Communication Links	22
Registration Programming and Testing	22
Zone Response Type Definitions.....	22
Zone Assignments	24
AN360 Programming Fields.....	24
Editing AlarmNet Services	24
Editing Total Connect 2.0 Services	25
Configuring Partitions and their Options.....	26
<i>Configuring Programming (Continued)</i>	28
Adding Sensors	28
<i>Configuring Programming (Continued)</i>	29
PROINDMV Setup and Configuration.....	29
Adding Keyfobs	30
Adding PROSIXLCDKP Keypads	30
Configuring Settings	31
System Operation	35
Keypad/Touchscreen Operation	35
PROSIXLCDKP Wireless Alpha Keypad Displays and Operation	35
Keypad Menu Mode	35
Keypad Supervision	35
PROWLTOUCH Touchscreen Displays and Operation.....	36
Master User Options	36
Amazon Alexa	37
Events	37
Wi-Fi Settings	37

System Displays.....	38
Partitioning.....	39
Goto Command.....	39
System Clock.....	39
Scheduling.....	39
Audio Alarm Verification (AAV) (Two-Way Voice).....	39
Security Codes.....	40
Programming Security Codes via Control Panel or Touchscreens.....	40
Z-Wave Locks and User Code Push.....	40
Keypad User Code Lockout.....	40
Disarming / Cancelling an Alarm / Clearing Alarm Memory.....	41
Rebooting the System.....	41
Panic Key/Icons.....	41
Event Log (Events).....	41
Contact ID® Event Log Codes.....	42
Central Station Messages.....	43
Confirming (Testing) the System.....	44
Test Modes.....	44
Communications Tests.....	44
Walk Test Mode.....	44
Normal Mode Test.....	44
Reporting Test.....	45
Automation.....	46
Introduction to Automation.....	46
Z-Wave Range.....	46
Additional Z-Wave Information.....	46
Accessing and Controlling Z-Wave Devices.....	47
Z-Wave Device Management Screen.....	47
Enrolled Devices.....	47
Including (Adding) Automation Devices.....	47
Excluding (Removing) Automation Devices.....	48
Network Wide Inclusion.....	49
Local Controller Info.....	49
Shift Controller.....	49
Update Network.....	49
Remove All Failed Devices.....	49
Reset Controller.....	49
Alexa.....	50
Bluetooth Disarm.....	51
Regulatory Agency Statements.....	53
Specifications.....	55
SIA Quick Reference Guide.....	55
NOTES NOTES.....	56
Contacting Technical Support.....	58
PROA7/PROA7PLUS RESIDENTIAL BURGLAR AND FIRE ALARM CONTROL PANEL SUMMARY OF CONNECTIONS.....	59

System Features

The PROA7/PROA7PLUS is a self-contained, rechargeable wireless Control Panel/Communicator that features easy installation and usage. A built-in speaker provides voice annunciation of system status along with voice descriptors of each zone. Internal modules allow the Control Panel to communicate with the Central Station via the Internet (if installed) or Cellular Wireless.

System Features	PROA7	PROA7PLUS
• 7.0-inch Color Graphic Touchscreen	✓	✓
• Partitions	4	4
• Voice Announcement of System and Zone Status	✓	✓
• Automatic Home (Stay) Arming	✓	✓
• Night Home (Stay) Arming	✓	✓
• User Codes (Master, Standard, Guest, Arm Only)	96	96
• User code Lockout	✓	✓
• Panic Functions (Police, Fire, Medical/Personal and Silent Police)	✓	✓
• Supports Auxiliary Wireless Touchscreens (PROWLTOUCH) and Keypads (PROSIXLCDKP)	✓	✓
• Audio Alarm Verification (AAV) (Two—Way Voice) - Utilizes the Control Panel and Wireless Touchscreens for voice stations	✓	✓
• Event Log	4,000	4,000
• RF Jam Detection for all supported wireless technologies	✓	✓
• Exit Error feature (detects difference between an actual alarm and exit alarm caused by leaving a door open after the exit delay expires)	✓	✓
• Built-in Case Tamper	✓	✓
• Optional Wall Mount Tamper	✓	✓
• Built-in Camera (takes a snapshot when the system is disarmed from the Main Panel. They can be viewed by the user in the panel Camera Log, and in Total Connect 2.0.)		✓
• Multi-Language (English, French, Spanish, Portuguese)	✓	✓
• Screen Saver	✓	✓
Home Automation		
• Integrated Z-Wave Plus Support (requires the PROWIFIZW module)	✓	✓
• Supports up to 78 Z-Wave devices with the following maximums: Light Modules: 60 Door Lock: 6 Z-wave Thermostats: 6* Wi-Fi Thermostats: 4* * Combination Z-Wave & Wi-Fi thermostats maximum = 6	✓	✓
• Supports Z-Wave Network Wide Inclusion (NWI) Mode	✓	✓
• Alexa Integration		✓
• Blue Tooth Disarming (BLE)		✓
Zones and Devices		
• 4 Panel Panic Zones	✓	✓
• Intrusion/Fire Zones	250	250
- PROSiX™/SiX™ Series devices (sensors)	127	127
- 5800™ Series wireless technologies (requires PROTAKEOVER module*) * The PROTAKEOVER module supports communication with certain previously installed wireless sensors and modules.	✓	✓
- PROSiX Series Keyfobs (8 button)	32	32
- 8 PROSiX Series Keypads/Touchscreens (supports PROSIXLCDKP Wireless Keypads and PROWLTOUCH Wireless Touchscreen) per partition	✓	✓
• 10 Temperature Zones	✓	✓
• 8 Wiselink – Motion Viewers		✓

System Features (Continued)

Alarm Output	PROA7	PROA7PLUS
<ul style="list-style-type: none"> Built-in 85db Sounder 	✓	✓
<ul style="list-style-type: none"> Steady Output for burglary/panic 	✓	✓
<ul style="list-style-type: none"> Temporal (3) Pulse Output for fire alarms 	✓	✓
<ul style="list-style-type: none"> Temporal (4) Pulse Output for carbon monoxide alarms 	✓	✓
Communication		
<ul style="list-style-type: none"> LTE Cell Communications (Backup path when used with a Wi-Fi connection) 	✓	✓
<ul style="list-style-type: none"> - PROLTE-A (ATT) 	✓	✓
<ul style="list-style-type: none"> - PROLTE-V (Verizon) 	✓	✓
<ul style="list-style-type: none"> - PROLTE-CN (Bell - Canada) 	✓	✓
<ul style="list-style-type: none"> Wi-Fi Central Station communication (PROWIFIZW Required) 	✓	✓ (included)
System Power		
<ul style="list-style-type: none"> Primary Power: Plug-in Power Supply, 110VAC to 9VDC, 2.5A output p/n 300-10260, (300-10260-CAN in Canada) 	✓	✓
<ul style="list-style-type: none"> Backup Battery: Rechargeable Lithium-ion Battery Pack p/n 300-10186, rated at 3.6/4.2Vdc, 7500 mAH 	24-Hour	24-Hour
Programming		
<ul style="list-style-type: none"> Options stored in Flash 	✓	✓
<ul style="list-style-type: none"> Can be uploaded, downloaded or controlled using capable Cellular or Wi-Fi Communications Module 	✓	✓
<ul style="list-style-type: none"> Flash Downloading 	✓	✓
<ul style="list-style-type: none"> Registered, programmed, and tested via AlarmNet 360™. Use a PC or Smart Device to go to: www.alarmnet360.com or the AlarmNet360 App. 	✓	✓
Agency		
<ul style="list-style-type: none"> UL / ULC Residential Burglary 	✓	✓
<ul style="list-style-type: none"> UL / ULC Residential Fire 	✓	✓
<ul style="list-style-type: none"> UL / ULC Commercial Burglary 	✓	✓

Proper Installation Steps

The proper steps for the PROA7/PROA7PLUS Control Panel to be installed are as follows:

1. **Create:** Create a Customer Account using the AlarmNet 360 App or web portal (www.alarmnet360.com)
2. **Connect:** Connect communication source and power up the Control Panel. Allow the system to register with AN360.
 - a. Install Cellular Communicator (PROLTE-A, PROLTE-V, or PROLTE-CN), Wi-Fi/Z-Wave (PROWIFIZW) module, and/or Takeover (PROTAKEOVER) module.
 - b. Mount the wall plate or attach the desk stand. Connect power supply wiring and install and connect the battery.
 - c. Secure the panel to the backplate and plug in the power supply (allow two minutes for the system to power up) and connect to a Wi-Fi network when prompted.
 - d. Allow the panel to connect to AN360 and download any programming that has been setup earlier.
3. **Configure:** Program the system (enroll sensors, keypads, Keyfobs, Z-Wave, users, & settings). **NOTE:** The Control Panel auto-syncs with every program change.
4. **Confirm:** Test the system and confirm that all programmed sensors are operational and reporting to the Central Station.
5. **Commission:** Commission the system and train the customer on the proper use of the PROA7/PROA7PLUS Control Panel and Total Connect 2.0.

Creating a Customer Account

From the programming menu select "+ New Account" in the upper right-hand corner of the page. Next, select the panel type as ProSeries.

Customer Information

New or Existing Customer	Select "New Customer" or "Existing Customer" (if creating additional account for one customer)
Customer Type	Select the "Customer Type" as Residential or Commercial
Customer Name and Contact details	Enter the first and last name; home, work, and cell phone numbers; customer's email address

Security

Location

Location Name	Enter the location name such as Home, Vacation Home, etc. (used with Total Connect 2.0)
Dealer Reference ID	Enter the internal account number specified for the customer. The maximum character limit is 25.
Sold By	Type the name of the Salesperson
Installed By	Type the name of the installation technician
Contract End Date	Set the contract end date by selecting the month, year, and date in the calendar

Address

Country	Select the country from the drop-down list
Address Line 1	Type the address of the customer
Address Line 2	Type the address of the customer
City	Type the City of the customer
State/Territory	From the drop-down list, select the state of the customer
Zip Code	Type the zip code of the customer. NOTE: this is not a mandatory field. If you have selected Total Connect account during Account Creation, ensure to add the zip code.
Notes	Type any extra information related to the customer

Control Panel

Type	Choose the Control Panel type from the drop-down list								
Revision	Select the correct revision of the control being installed								
Would you like to enter the MAC ID now?	Select "Yes" and enter the MAC ID and CRC of the communicator being installed.								
Alarm Reporting Number	This is the CITY-CS-SUB account number for the communicator.								
Continue	The security account is verified based on the CITY-CS-SUB, MAC ID, and whether the Control Panel revision and communicator type are compatible.								
Packages	Select the required package from the drop-down menu.								
Add-Ons	<table border="1"> <tr> <td>Two Way Voice</td> <td>Select to Enable two-way communication between the Control Panel and the Central Station, following an alarm condition.</td> </tr> <tr> <td>Video Alarm Verification</td> <td>Select to enable Central Station supported video alarm verification.</td> </tr> <tr> <td>Advanced Protection Logic</td> <td>Always Enabled and adds additional assurance that signals are sent to the Central Station in the event that the alarm system equipment is compromised prior to sending an alarm.</td> </tr> <tr> <td>Video Service</td> <td>Based on the selected service level, the video clip from the camera is retained. (PROA7PLUS Only)</td> </tr> </table>	Two Way Voice	Select to Enable two-way communication between the Control Panel and the Central Station, following an alarm condition.	Video Alarm Verification	Select to enable Central Station supported video alarm verification.	Advanced Protection Logic	Always Enabled and adds additional assurance that signals are sent to the Central Station in the event that the alarm system equipment is compromised prior to sending an alarm.	Video Service	Based on the selected service level, the video clip from the camera is retained. (PROA7PLUS Only)
Two Way Voice	Select to Enable two-way communication between the Control Panel and the Central Station, following an alarm condition.								
Video Alarm Verification	Select to enable Central Station supported video alarm verification.								
Advanced Protection Logic	Always Enabled and adds additional assurance that signals are sent to the Central Station in the event that the alarm system equipment is compromised prior to sending an alarm.								
Video Service	Based on the selected service level, the video clip from the camera is retained. (PROA7PLUS Only)								

Total Connect 2.0

Create New Account	Select to create a new Total Connect account for the panel.
Use Existing Account	Select to use an existing Total Connect account for the panel.
TC2 Account Name	Type a name for the account
TC2 Master User Name	Type a master user name for the account. This is the Username your customer uses when logging in.
TC2 Master user E-Mail ID	Type a master user E-Mail ID for the account
Total Connect 2.0 Plan	Select the Total Connect 2.0 Plan
Panel Master Code	Type the master code of the panel. This code is available on your Control Panel.
Location Zip Code	Type the zip code of your location
Pre-configure Total Connect 2.0 Account	Select this feature to enable pre-configuration of Total Connect 2.0 account prior to sending welcome e-mails to your customer.
Does the customer have a SkyBell Account?	Based on the account availability, select the relevant option and proceed.

End User Preferences

Language	From the list, select to program a user-friendly language for the application.
Time Zone	From the list, select the time zone.
Date Format	Select to set the date format.
Time Format	Select to set the time format.
Notifications	From the list of available notifications, you can click to: Select/Deselect All, or Select the relevant notifications.

Once all fields have been addressed click "Finish" on the top-right corner of the page. A summary screen is provided to check the details again and click "Confirm Creation".

Connect the Control Panel

Backup Battery Installation

The Control Panel is equipped with an integral, replaceable, rechargeable battery pack rated at 3.6/4.2Vdc. In the event of an AC power loss, the system is supported by the long-life backup battery that is supervised for connection and for low voltage conditions. If the battery is missing, or a low battery condition is detected, a “low battery” message is displayed, and a report is sent to the Central Station. In addition, the system beeps once every 60 seconds to audibly indicate a low battery condition (press any key to stop the beeping). Follow the steps and refer to the figure below to install and connect the battery.

Battery Part Number	Battery Standby Time	Low Battery Notification
300-10186	24-hours (minimum)	At least 1-hour before battery depletion

Installing the Rechargeable Backup Battery

1. Insert the battery pack into the case.
2. Connect the battery connector to the receptacle on the PC board.
3. Install the side cover.
- 4a. Connect the power cable to the GND and +9V terminals on the wall mount and to the + and – terminals on the Power Supply. Refer to the Wiring Table (on page 9) for maximum wire gauge and length. **Do not apply power at this time.** OR
- 4b. Connect the power supply connector to the receptacle on the desk mount. **Do not apply power at this time.**

NOTE: If using the optional wall mount configuration, refer to the wall mounting procedure. If using the Desk Mount refer to the desk mounting procedure.

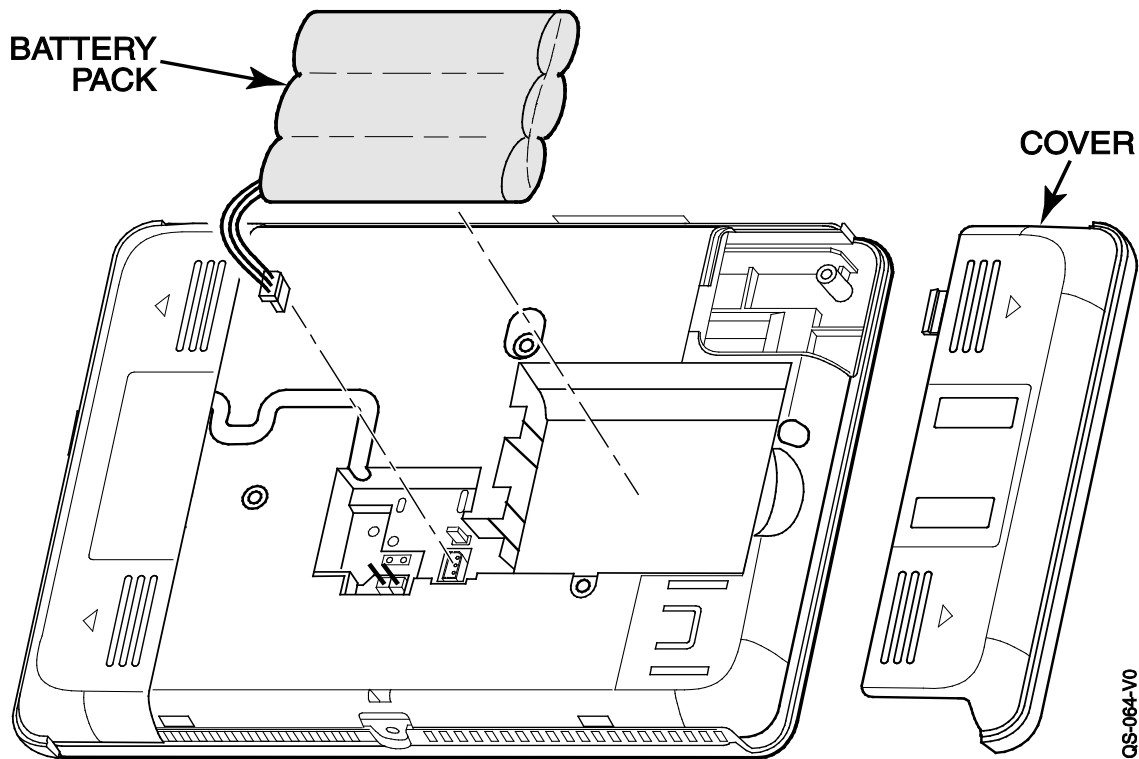

Rechargeable batteries may take up to 24-hours to fully charge. The “System Low Battery” message displays until the battery is fully charged.

System Low Battery Messages

The “System Low Battery” message may be displayed on the Keypads/Touchscreens. The message displays until the battery is fully charged. Additionally, when the low battery condition exists the Keypads/Touchscreens emit one beep every 60 seconds. The beeps can be silenced by pressing any key on the Keypads/Touchscreens. The beeps only need to be silenced one time and they are not emitted again. No further action is required. The “Low Battery” message clears automatically when the battery is fully charged. Additionally, the system sends a Low Battery Restore (CID R302) message to the Central Station.

Connect the Control Panel (Continued)

Replacing the Rechargeable Backup Battery

When battery replacement is required, remove electrical power (refer to the *System Shutdown* section for additional information) and follow the steps below.

Remove the battery

1. Unscrew the screw securing the Control Panel to the wall or desk mount.
2. Release the catch that secures the Control Panel to the wall or desk mount.
3. Rotate the Control Panel and lift it from the wall or desk mount, being careful not to damage the wiring.
4. Remove the side cover.
5. Disconnect the battery pack connector from the receptacle on the back of the PC board.
6. Remove the battery pack from the case.

Install the replacement battery

1. Insert a replacement battery pack p/n 300-10186 into the Control Panel.
2. Connect the battery connector to the receptacle on the PC board.
3. Install the side cover.
4. Connect the power supply connector to the receptacle on the desk mount. **Do not apply power at this time.**
5. Install the control onto the wall or desk mount.
6. Install the screw to secure the control.
7. Plug the power supply into a 24-hour, 110VAC non-switched outlet. Upon power-up, the "System Standby!" screen displays.
NOTE: Allow up to two minutes for power-up.

NOTE: If a Cellular Communication Module is being installed, verify the module's signal strength before selecting a final mounting location. Refer to *Checking the Signal Strength* in the Communications Module section.

Wall Mounting

NOTE: When selecting a location for the Control Panel, be sure to provide a separation of at least 10 feet between 2.4GHz devices such as Wi-Fi Routers/Access Points.

For wall mounting follow the steps and refer to the figure below.

1. Feed the field wiring through the appropriate openings in the wall mount.
2. Attach the wall mount to a sturdy wall using the provided screws.
3. If required, install an additional mounting screw in the case tamper.
4. Align the cleats on the back of the Control Panel with the slots on the wall mount as shown below.
5. Snap the Control Panel into place.
6. Once attached, insert the screw to secure the Control Panel to the wall mount.

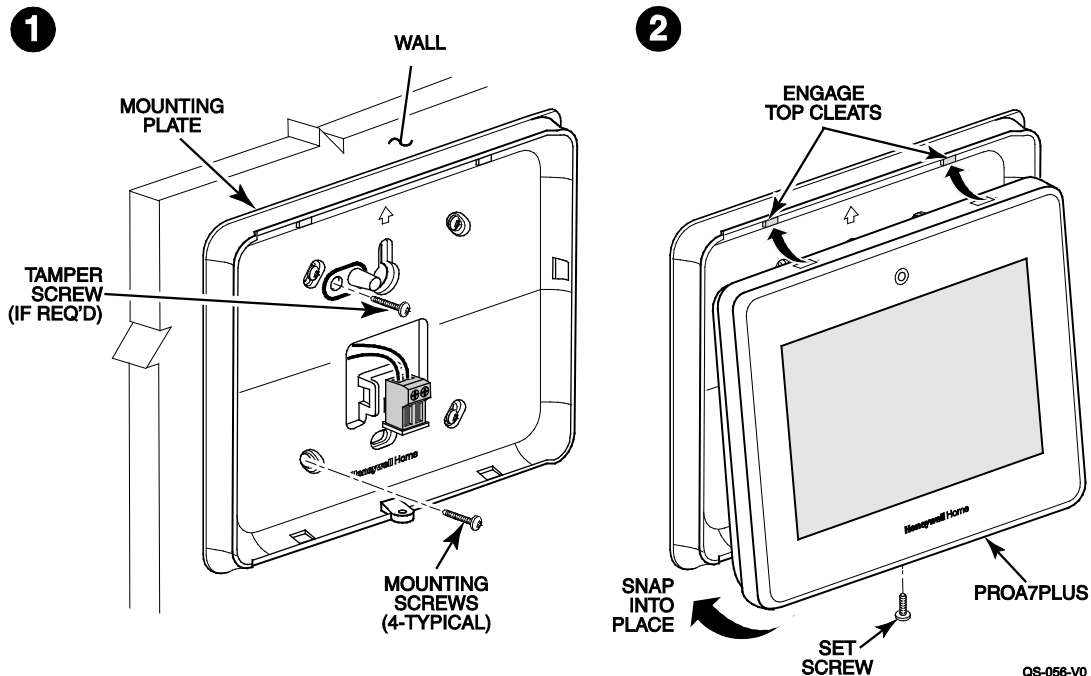

Connect the Control Panel (Continued)

Desktop Mounting

NOTE: When selecting a location for the Control Panel, be sure to provide a separation of at least 10 feet between 2.4GHz devices such as Wi-Fi Routers/Access Points.

The PROA7DM is intended for use with the PROA7/PROA7PLUS Control Panels and can be positioned at a 60° or 30° angle.

1. Choose the desired angle and align the hooks on the desk stand with the slots on the backplate.
2. Slide the desk stand **up** to lock it in place. To use the other position, flip the stand the other way before fitting it to the backplate.

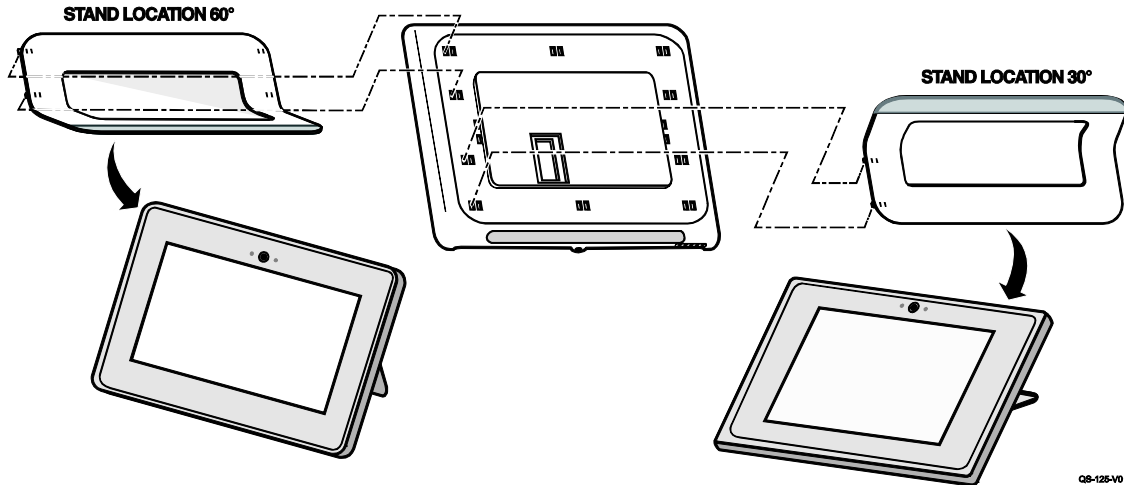

QS-125-V0

3. Install the PROA7/PROA7PLUS on the desk stand and lock it into place.
4. Install the set screw.

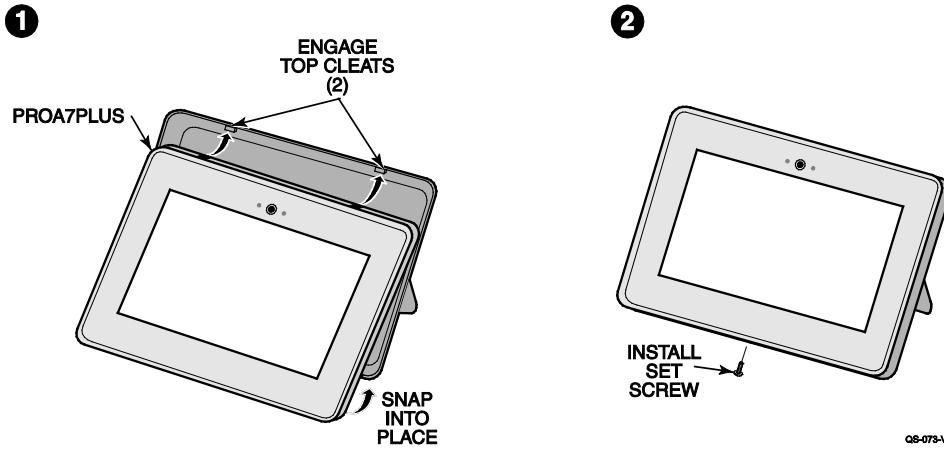

QS-078-V0

5. Route the power supply cable through the opening in the desk mount and connect it to the receptacle on the PROA7/PROA7PLUS.

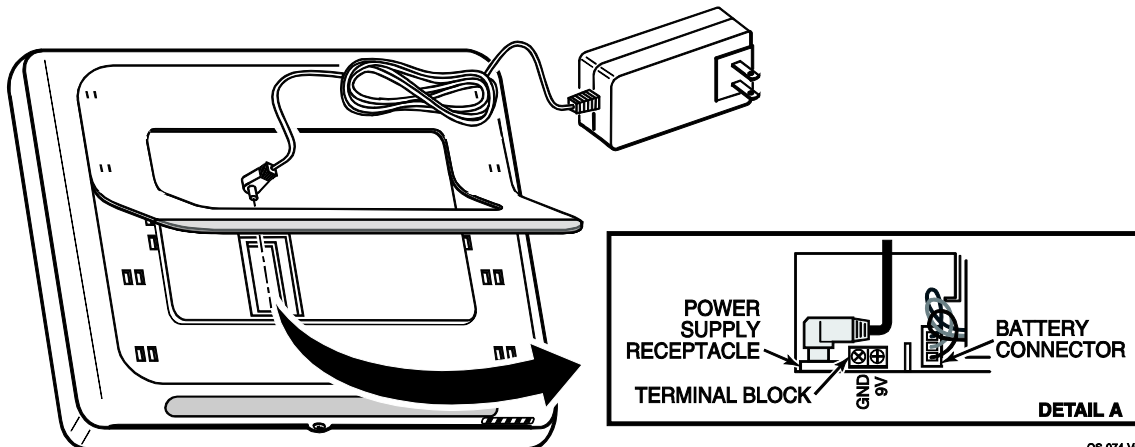

QS-074-V0

Connect the Control Panel (Continued)

Communication Modules

The Control Panel supports Central Station reporting using wireless/cellular and Wi-Fi communications devices as well as upload/download programming capability via the Internet. This allows site maintenance independent of Central Station monitoring, and modification to sites globally via the Internet. Additionally, an internal Z-Wave module allows the Control Panel to support Home Automation functions while a Converter module is used to support other wireless technologies. (P/N 800-25182 for additional information.) The Control Panel is compatible with the following Communication Modules:

Model	Description
PROLTE-A	LTE Cellular Communications Module (US/Canada, AT&T network)
PROLTE-V	LTE Cellular Communications Module (US, Verizon network)
PROLTE-CN	LTE Cellular Communications Module (Canada, Bell)
PROWIFIZW	Z-Wave/Wi-Fi Communications Module
PROTAKEOVER	Wireless Converter Module



RF Exposure

WARNING: The Control Panel must be installed to provide a separation distance of at least 7.8 in (20 cm) from all persons and not co-located or operated in conjunction with any other transmitter except in accordance with FCC multi-transmitter product procedures.



Ensure that all electrical power has been removed from the Control Panel before installing communication modules. Refer to the *System Shutdown* section for additional information.

Installing the PROLTE Series Cellular Communications Module

Follow the steps and refer to the figure below to install the LTE Communications Module.

1. Remove electrical power (if applied). Refer to the *System Shutdown* section for additional information.
2. Remove the screw securing the control to the wall mount or desk mount.
3. Rotate the Control Panel and lift it from the wall or desk mount, being careful not to damage the wiring.
4. Remove the left side cover.
5. Insert the module into the slot on the left side of the Control Panel as shown and ensure the receptacle is securely seated on the Control Panel's edge connector.
6. Install the set screw
7. Install the cover
8. Install the control onto the wall or desk mount.
9. Install the screw to secure the control.
10. Plug the power supply into a 24-hour, 110VAC non-switched outlet. Upon power-up, the "System Standby!" screen displays. **NOTE:** Allow up to two minutes for power-up.

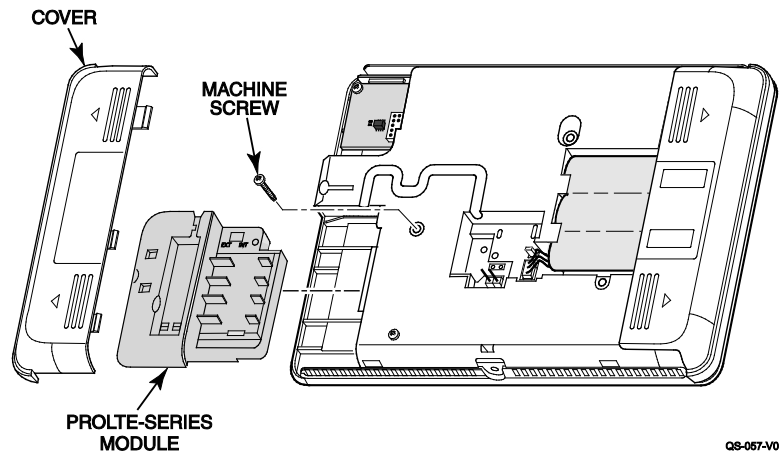

QS-057-V0



IMPORTANT: A cellular or Wi-Fi communicator is required to register the Control Panel.

Connect the Control Panel (Continued)

Communication Modules (Continued)

Installing the PROWIFIZW Wi-Fi and Z-Wave Communications Module

Follow the steps and refer to the figure below to install the Wi-Fi/Z-Wave Communications Module. **NOTE:** this module comes preinstalled in the control (PROA7PLUS Only).



Ensure that all electrical power has been removed from the Control Panel before installing communication modules. Refer to the *System Shutdown* section for additional information.

1. Remove electrical power (if applied). Refer to the *System Shutdown* section for additional information.
2. Remove the screw securing the control to the wall mount or desk mount.
3. Rotate the Control Panel and lift it from the wall or desk mount, being careful not to damage the wiring.
4. Remove the left side cover.
5. Insert the module into the slot on the left side of the Control Panel as shown and ensure the receptacle is securely seated on the Control Panel's edge connector and secured with the provided screw.
6. Install the cover
7. Install the control onto the wall or desk mount.
8. Install the screw to secure the control.

Plug the power supply into a 24-hour, 110VAC non-switched outlet. Upon power-up, the "System Standby!" screen displays. **NOTE:** Allow up to two minutes for power-up.

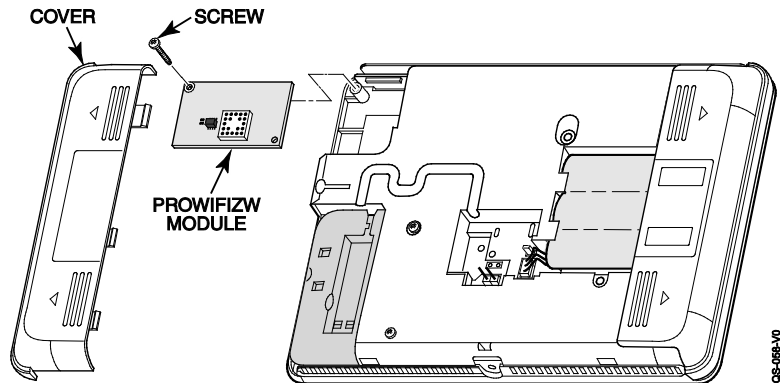

Connect the Control Panel (Continued)

Communication Modules (Continued)

Installing the PROTAKEOVER Wireless Converter Module

Follow the steps and refer to the figure below to install the Wireless Converter Module. Refer to the PROTAKEOVER module Installation Instruction (p/n 800-25182) for additional information.



Ensure that all electrical power has been removed from the Control Panel before installing communication modules. Refer to the *System Shutdown* section for additional information.

1. Remove electrical power (if applied). Refer to the *System Shutdown* section for additional information.
2. Remove the screw securing the control to the wall mount. Rotate the Control Panel and lift it from the wall mount, being careful not to damage the wiring.
4. Remove the right side cover.
5. Set the rotary switch on the PROTAKEOVER module to the setting associated with the existing wireless sensors and modules and the Control Panel. Refer to the table for the supported protocols.
6. Insert the PROTAKEOVER module into the slot on the right side of the Control Panel as shown and ensure the receptacle is securely seated on the Control Panel's edge connector. Secure with the provided screw.
7. Reinstall the access cover, taking care to avoid bending the contacts on the module.
8. Remove the existing wall mount and replace with the wall mount (containing the integrated antenna) provided with PROTAKEOVER module.

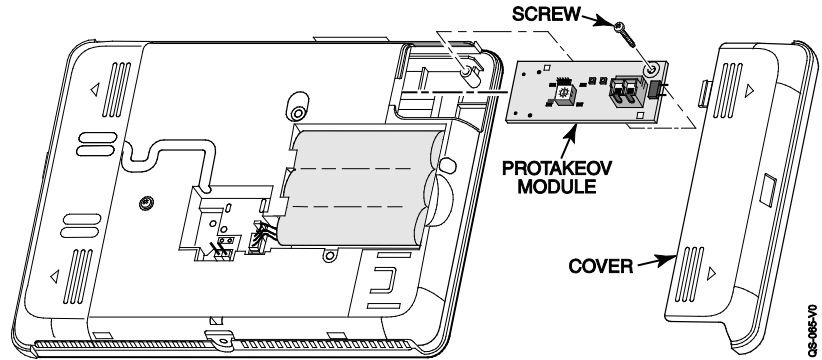

Take Over Module Rotary Switch Settings	
Protocol	PROA7/PROA7PLUS
5800	0
2GIG	1
DSC	2
ITI/Qolsys	3
Bosch	4

Note: To avoid damaging the connector pins on the module, do not force the rear case during the installation.

9. Install the control on the replacement wall mount and secure with the screw.

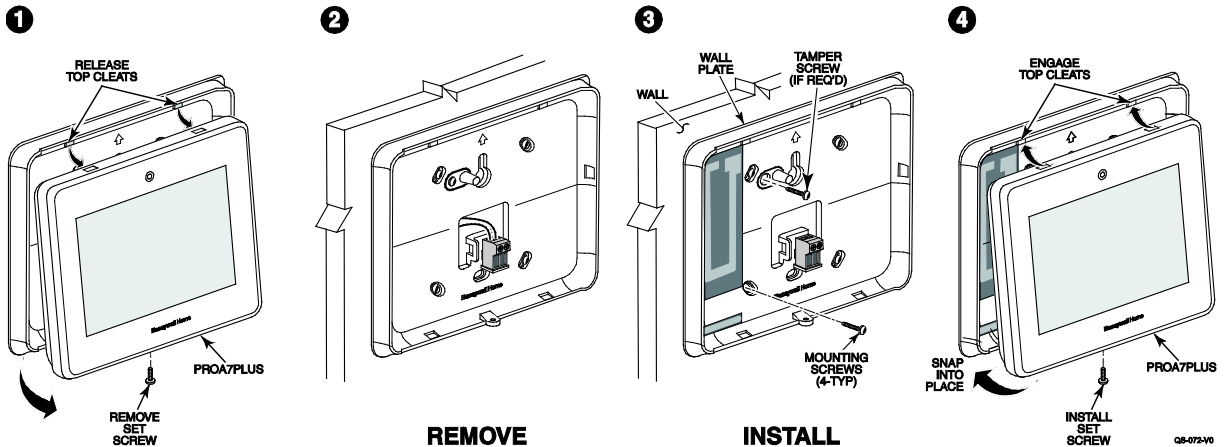

NOTE: The PROTAKEOVER module supports communication with certain previously installed wireless sensors and modules. Refer to PROTAKEOVER Compatibility chart (p/n R800-26221 or later) for a list of tested and approved vendor wireless devices.

Connect the Control Panel (Continued)

AC Power

The Control Panel is powered by a 9VDC, 2.5 Amp Plug-in Power Supply, 300-10260 (300-10260-CAN in Canada). Refer to the wiring table below for wire gauge and length.

WIRING TABLE

Maximum Cable Length Between Power Supply and Control Panel	Wire Gauge (AWG)
Up to 25 feet (7.62m)	# 22
Up to 45 feet (13.72m)	# 20
Up to 70 feet (21.34m)	# 18
Up to 110 feet (33.53m)	# 16



Use only the 300-10260 (300-10260-CAN Canada) Power Supply. Do not plug the power supply into the AC outlet until after all wiring connections have been made.

Wiring Overview

The following summarizes the electrical connections associated with the Control Panel. Follow the steps and refer to the Summary of Connections diagram for additional information.

Make Electrical Connections

1. Remove the Control Panel's rear case/backplate.
- 2a. Connect the power cable to the GND and +9V terminals on the Control Panel and to the + and – terminals on the Power Supply. Refer to Wiring table for wire gauge and length. OR
- 2b. Connect the power supply connector to the receptacle on the Control Panel.
3. Install the rear case/backplate onto the Control Panel and secure with the screw.

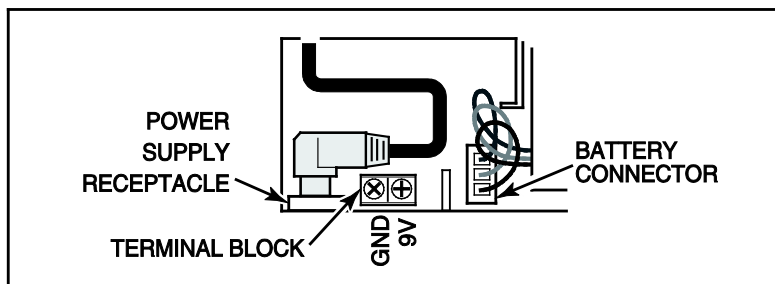

Summary of Connections

Initial Configuration

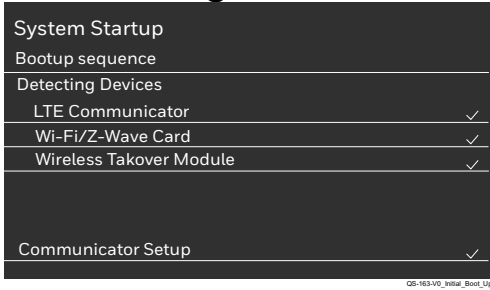

Before connecting power to the Control Panel, the customer's account must be configured in AlarmNet 360 (AN360) located at www.alarmnet360.com. Refer to the Creating Customer Account section above for more information.

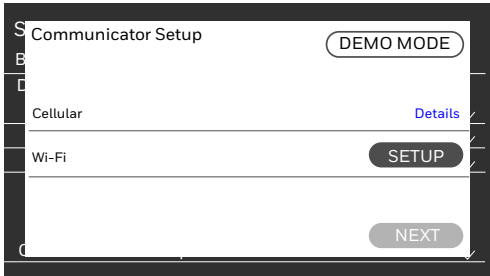

Touch "Details" to view the Cellular Communicators ID numbers.

If using Wi-Fi, touch "Setup" to configure. If not using Wi-Fi, touch "Next".

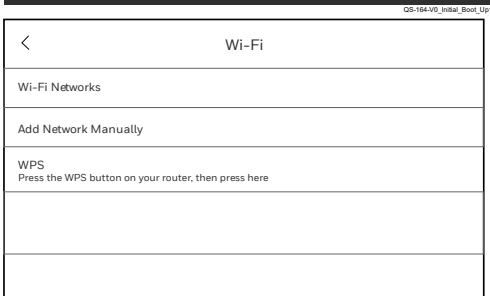

- Touch "Wi-Fi" Networks to select from a list of broadcasted networks. Follow the on-screen prompts to connect to the network.
- Touch "Add Network Manually" if connecting to a hidden network.
- If using the WPS option to connect to the network, start the WPS process on the router first, then touch the WPS option on the screen.

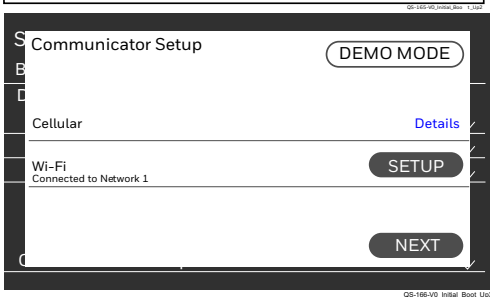

Once connected to the Wi-Fi network touch "Next".

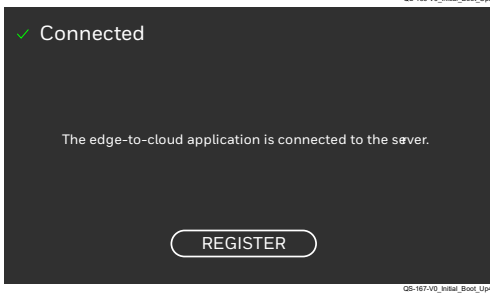

After "Next" was touched the Control Panel attempts to connect to the edge-to-cloud server in AN360.

Touch "REGISTER" to start the registration process.

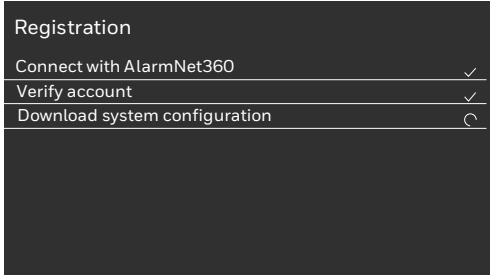

The Control Panel connects, verifies the account information, and then downloads the pre-existing configuration to the Control Panel. Next, the home screen appears.

Configure Wireless Devices

Sensors

All devices and sensors are setup, programmed, and tested via AlarmNet 360. Use a PC or Smart Device to go to: www.alarmnet360.com or use the AlarmNet360 app. The Control Panel supports up to 250 total wireless zones; 127 of which can be PROSiX/SiX™ Series Wireless while any of them can be 5800 Series or another technology:

- PROSiX/SiX™ Series Wireless
- 5800™ Series wireless technologies (requires PROTAKEOVER module) Communicates with wireless devices that transmit on the following frequencies 319.5MHz, 345MHz, 433.42 and 433.92MHz. Refer to the PROTAKEOVER Compatibility chart for a list of compatible devices. Only one of these technologies can be used at one time.



IMPORTANT: Once paired, PROSiX/SiX™ Series transmitters cannot be used with another Control Panel until they are unpaired (deleted) from the current Control Panel. When being unpaired, the transmitters must be powered up and within range of the Control Panel so the transmitters can receive the unpairing signal. Devices can only be unpaired via AlarmNet 360. Some SiX™ transmitters can be defaulted manually within 24hrs of being paired to the Control Panel. Check the installation instructions of that transmitter for details.

Range

The range of any wireless device ultimately depends on the building construction. The ranges specified below are typical for most installations.

- PROSiX/SiX™ Series Wireless has a nominal range of 300+ feet @ 2.4GHz.
- 5800™ Series Wireless has a nominal range of 200 feet @ 345MHz.

Frequency Agility

Communications between the Control Panel and SiX™ Series transmitters are automatically monitored by the panel. When excessive environmental interference (i.e. from Wi-Fi routers) is detected on the 2.4GHz channel, the Control Panel automatically switches to a quieter channel to allow clearer communication.

One-Go-All-Go

SiX™ Series transmitters are bi-directional, so they not only send signals to the Control Panel, but they also receive signals from the Control Panel. If enabled in programming, the Control Panel sends a signal to all devices (i.e. smoke, CO, or combo devices) during a fire or CO alarm causing all of those devices to sound. This also applies to PROSiX/SiX Series Keypads / Touchscreens and Sirens, which all sound for burg alarms as well.

Smoke / CO Maintenance

The PROSiX/SiX™ Series smoke detectors and smoke / CO combo detectors can send "High Sensitivity" or "Low Sensitivity" Maintenance signals when they become too dirty to detect smoke or if they become too sensitive. End-of-Life (EOL) is also supported for CO detectors.

Transmitter Supervision

Each transmitter is supervised by a check-in signal that it sends to the Control Panel. If at least one check-in is not received from each supervised transmitter within their designated time period, the "missing" transmitter's zone number(s) and "Supervision" is displayed and it initiates a trouble signal, no matter if the panel is armed or disarmed. The supervision for a transmitter can be disabled by programming it as "Unsupervised" so that it may be carried off the premises, such as a panic button. If set for Unsupervised, the Control Panel ignores ONLY the supervision signals it receives from that transmitter, but still recognizes all other signals, including Low Battery. Both SiX™ and 5800™ Series transmitters have built-in tamper protection and initiates a trouble condition if the Control Panel is disarmed and an alarm if it is armed. Wireless keys are not supervised.

- PROSiX/SiX Series Burg and panic transmitters send a check-in signal every 60 minutes with a 12-hour panel check.
- PROSiX/SiX Series Life Safety transmitters send a check-in signal every 60 seconds with a 2-hour panel check. These include smoke / CO detectors, and sirens.
- PROSiXLCDKP keypads are supervised at 15-minute intervals
- 5800™ Series transmitters send a check-in signal every 70-90 minutes with a 12-hour panel check.
- A power cycle of the Control Panel or a "System Reboot" via touchscreen restarts the 12-hour timer.

Wireless Devices (Continued)

Transmitter Battery Life

Batteries in the wireless transmitters may last from 4–10 years, depending on the environment, usage, and the specific wireless device being used. Factors such as humidity, high or low temperatures, as well as large swings in temperature may all reduce the actual battery life in any installation. The wireless system can identify a true low battery condition, thus allowing the dealer or end user time to arrange a change of battery and maintain protection for that point. Batteries should be replaced within 2 weeks of going into a low battery condition.



IMPORTANT: SiX™ and 5800™ Series transmitters draw quick bursts of current during transmission, then sit idle with very nominal current draw. Most batteries are not designed for this type of use, therefore, only batteries listed as compatible should be used to attain if the expected battery life. Each transmitter's Installation Instructions lists compatible battery manufacturers and their part numbers. When other non-approved batteries are used, the quick bursts of current draw kill the battery cells prematurely causing them to go low in a matter of months and can also cause unpredictable results. Other low quality batteries have not been UL tested and pose a safety hazard if used.

Testing Signal Strength

This system provides a sensor walk test mode for checking wireless signal strength. The battery status and signal strength for PROSiX/SiX™ Series transmitters are displayed in AlarmNet 360 and through the PROA7/PROA7PLUS Control Panel (press Menu > Sensors).

Important Security Notice

Please inform the User about the security importance of their wireless key (key fob), and what to do if it is lost. Explain that the wireless key is similar to their keys or access card. If lost or stolen, another person can compromise their security system. They should immediately notify the Dealer/Installer of a lost or stolen wireless key. The Dealer/Installer then removes the wireless key programming from the security system.

Keypad / Touchscreen Setup

The PROSiXLCDKP must be paired with the Control Panel via the AlarmNet 360 Programming Tool. Use a PC or Smart Device to go to: www.alarmnet360.com or the AlarmNet360 App. After putting the system into Learn Mode, power up each device or initiate the pairing sequence individually to pair the keypad with the system. The wired keypads/touchscreens do not power up on battery alone; they must be powered up with their supplied transformer.

PROSiXLCDKP Wireless Keypad

The PROSiXLCDKP keypad attempts to pair automatically upon power up. If it is not paired during power up, any button can be pressed or power cycle the unit to restart the pairing process. The keypad can be either wall or desk mounted. Desk mounting requires the optional PROSiXLCDDM kit. For additional information refer to the PROSiXLCDKP Installation and Setup Guide (p/n 800-25152 or later).

The keypad can be either wall or desk mounted using the optional PROSiXLCDDM kit. For additional information refer to the Installation and Setup Guide (p/n R800-25933 or later).

When wiring the wall mount, use the wire table below to determine the gauge of wire needed between the transformer and mounting plate. For proper wiring instructions, refer to the Installation and Setup Guide (p/n 800-25152 or later).

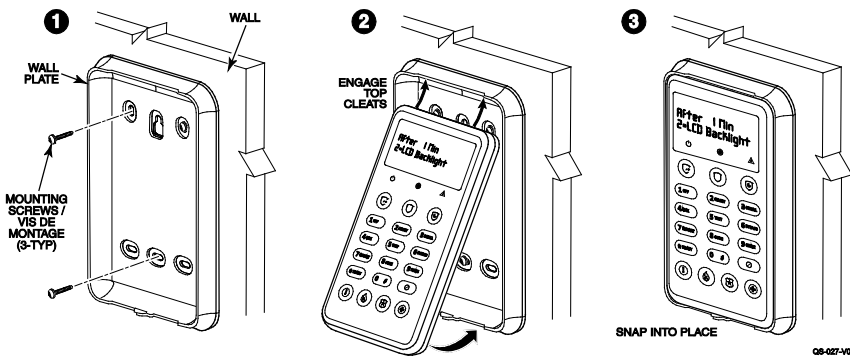

Maximum Cable Length Between Keypad and Power Supply	Wire Gauge (AWG)
Up to 19ft (5.8m)	#22
Up to 30ft (9m)	#20
Up to 51ft (15.5m)	#18
Up to 75ft (23m)	#16



The keypad is powered by a 9Vdc, 1.5A plug-in transformer, P/N 300-07332US or 300-07332-CAN (Canada). Use the above chart to determine the length of the wire run and the gauge for the installation.



IMPORTANT: The wireless keypad uses SiX™ technology. Once they are paired to the Control Panel, they cannot be used with another Control Panel until it is unpaired (deleted) from the current Control Panel. When being unpaired, the keypads must be powered up and within range of the Control Panel, so they can receive the unpairing signal. Devices must be unpaired via AlarmNet 360.

Wireless Devices (Continued)

PROWLTOUCH Wireless Touchscreen

The PROWLTOUCH Touchscreen communicates to the Control Panel via Wi-Fi. The Control Panel must have the PROWIFIZW Wi-Fi module installed; and connected to the same router the PROWLTOUCH. Wireless Touchscreens (if installed), are functionally the same as the Control Panel. They duplicate the Control Panel's displays and functions. Most everything that can be done at the Control Panel can also be done at the Touchscreen. The PROWLTOUCH communicates to the Control Panel via Wi-Fi. It can be either wall mounted with the wall docking station or desk mounted with either the built-in desk stand or separate optional desk mount. The built-in desk stand option angles the touchscreen at approx. 30°. **NOTE:** when pairing, the Control Panel must not be in sensor learn mode.

PROWLTOUCH Wireless Touchscreen

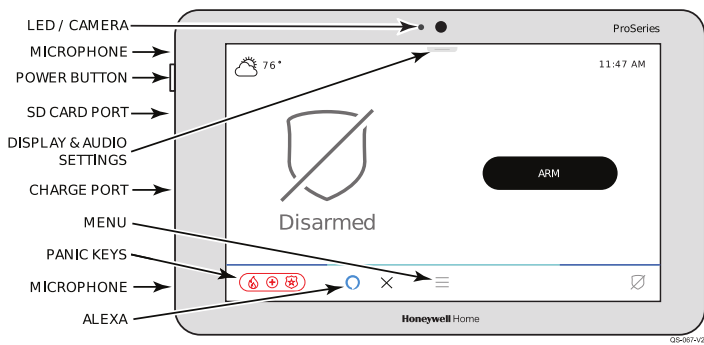

Status LED	Meaning
Red - Steady	System Armed
Red - Flashing	Alarm / Alarm Memory
Amber - Steady	System trouble
Amber - Flashing	Device trouble – System cannot be armed
Green - Steady	Ready to Arm
Green - Flashing	Device trouble - System can be armed
Green & Red Alternately Flashing	System is in Programming Mode
Off	Not ready to Arm

NOTE: The power button has 2 different functions:

- Press and Release toggles the screen off and on
- Press and Hold to display the options of Power Off or Restart.

Touchscreen Mounting Options

Built-In Desk Stand

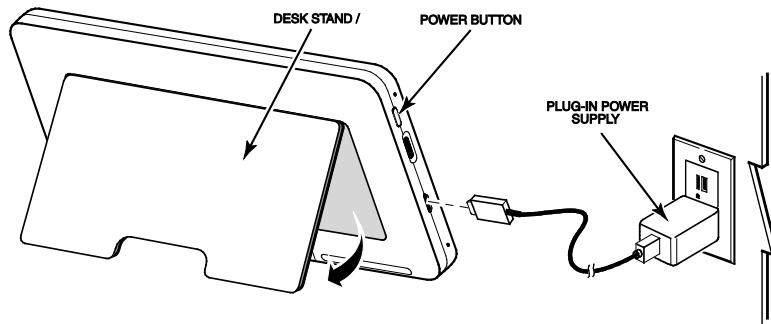

The touchscreen can be powered by the supplied micro USB cable and the 5Vdc, 1.5A plug-in transformer. For optimal performance, use the supplied transformer to charge the Lithium Ion Polymer battery. The battery may not charge properly if it's plugged into any other USB port.

PROWLTOUCHWM (Sold Separately)

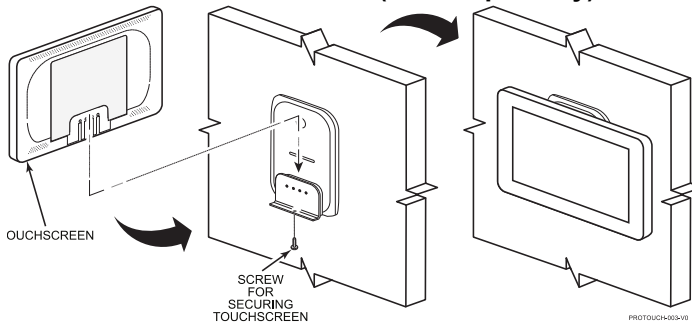

PROWLTOUCHDM (Sold Separately)

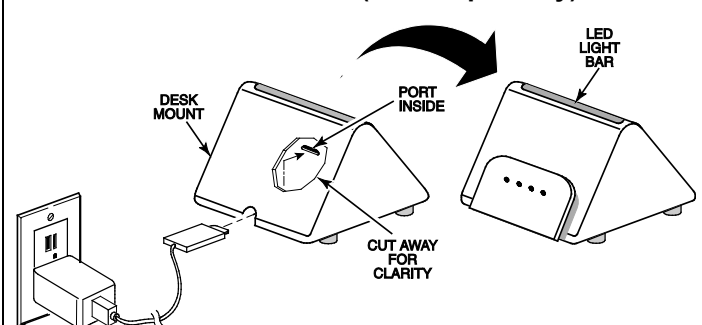

Wireless Devices (Continued)

Connecting the PROWLTOUCH to Wi-Fi

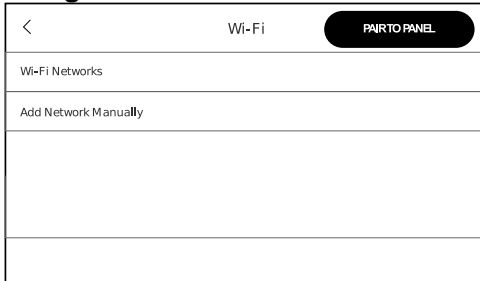

1. After powering up the PROWLTOUCH Touchscreen, it prompts you to enter Wi-Fi Networks or Add Network Manually. To pick from a list of available networks press Wi-Fi Networks.

NOTE: Panel must not be in Sensor Learn Mode

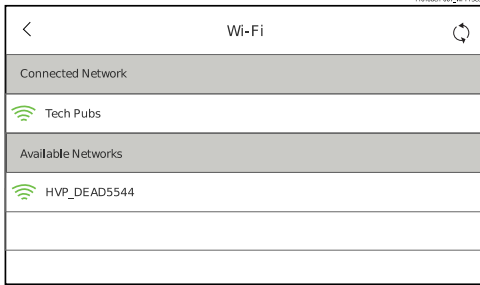

2. Select the network.

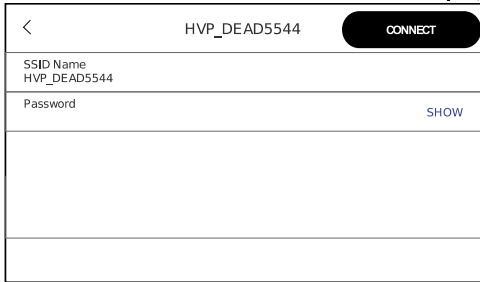

3. Enter the correct password and press Connect.

NOTE: As long as the PROA7/PROA7PLUS is connected to the same Wi-Fi network, it acquires the IP address of the PROA7/PROA7PLUS and pairs with the Control Panel.

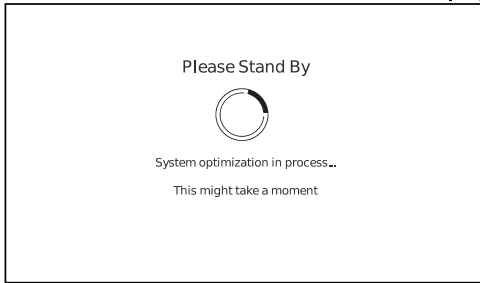

4. PROWLTOUCH searches for the IP address of the Control Panel. When it finds the IP address of the Control Panel it displays:



Wireless Devices (Continued)

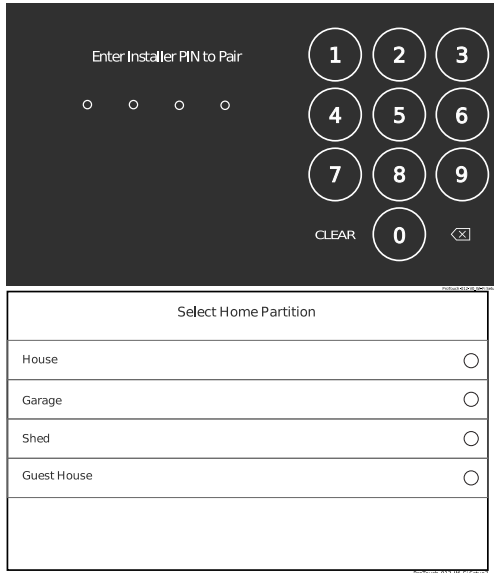

5. Enter the 4-digit Installer PIN to Pair with the Control Panel.
6. Select the Home partition for this keypad.
7. Once the PROWLTOUCH is successfully paired, it shows in AN360 under keypads. There you can edit the name and partition assignment or delete the keypad if desired.

Configuring Programming

Navigating Menus

Touchscreen Display

The Control Panel's Liquid Crystal Display (LCD) touchscreen displays variable icons and text on "screens". The screen displays status icons and associated text, the current time and date, system status information and menu choices. The Menu area includes a list of commands, or choices that apply to the current selection. The status area provides information about various system events and a colored bar also provides an indication of system status. A "Home Screen" is displayed whenever power is applied to the system. System status is also indicated by the Power (left) and Status (right) Status LEDs.

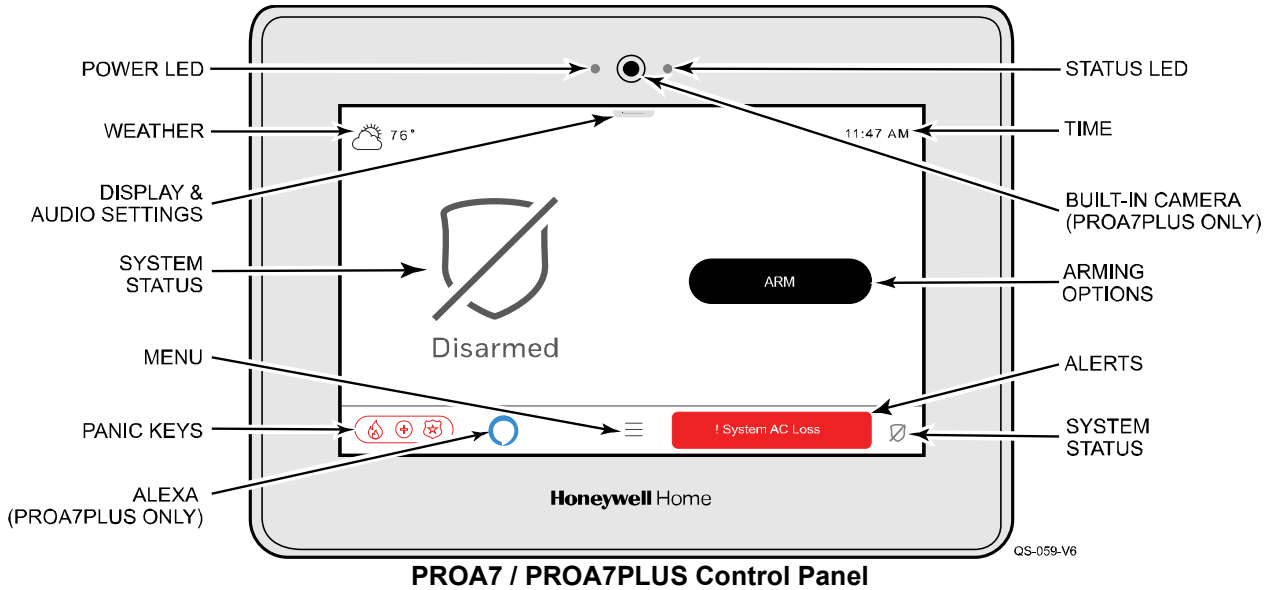

System Status LED Functions

LED	Status	Meaning
Power (Left)	Green – Steady	AC Connected/Battery Charged
	Off	No AC Power
Status (Right)	Green – Steady	System Ready to Arm
	Amber – Steady	System trouble
	Red – Steady	System Armed
	Red Flashing	Alarm or Alarm Memory
	Red/Green – Flashing	System in Programming mode
	Off	Not ready to arm

Configuring Programming (Continued)

Navigation Keys/Home Screen

System Status is displayed below the large icon on the left side of the touchscreen. In addition, the Home Screen displays the current weather, date and time and selectable options are displayed on a separate menu. Select the Menu icon to display the available Menu options.

Navigating through the screens is accomplished by lightly touching the icons or menu items on the touchscreen. Once activated, the Control Panel advances to the next screen, toggles between options or scrolls through multiple options that can be selected. The system provides a prompt when a specific input is required.

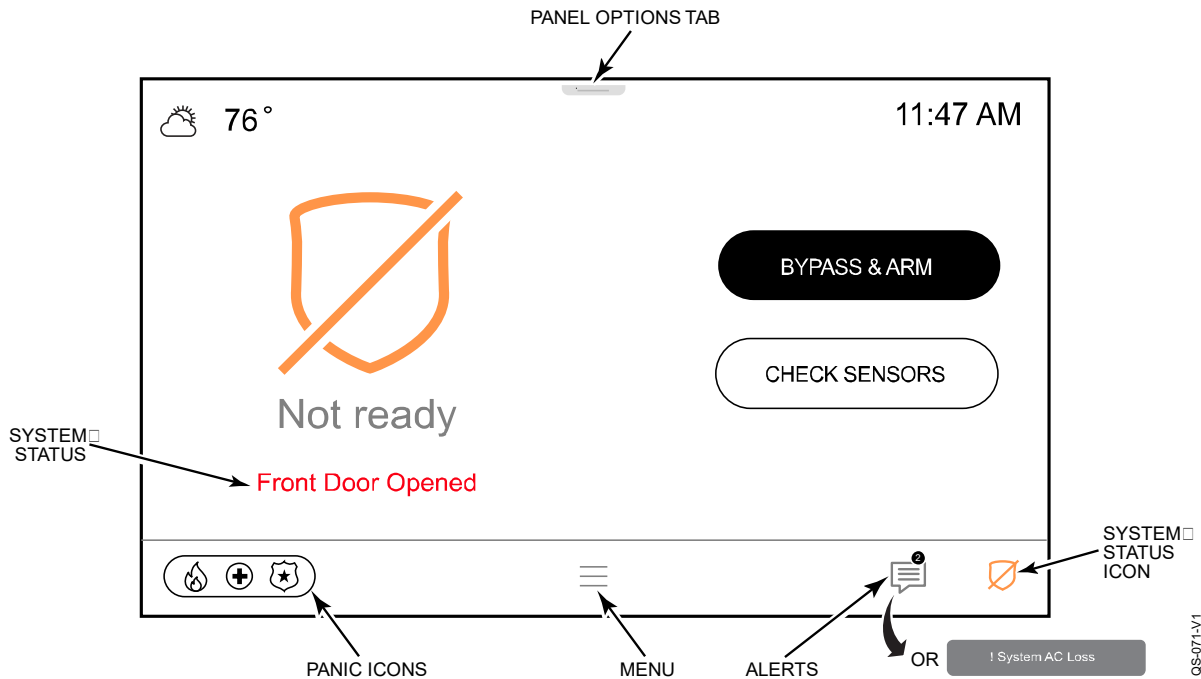

Home Screen (Page 1 shown)









Icon	Function
 Armed Away	Indicates the system is armed in Away mode.
 Armed Home	Indicates the system is armed in Home (Stay) mode
 Armed Night	Indicates the system is armed in Night mode
 Disarmed	Indicates the system is disarmed and Ready to Arm.
 Not Ready	Indicates the system is disarmed and Not Ready to Arm.
 Panic Keys	Access to programmed Panic Keys such as Fire, Police, Medical.
 Alerts	Displayed when Alert Message(s) are Present

Icon	Function
 Alexa	Indicates Amazon Alexa has been enabled.
 Fire	Alerts Central Station of a fire condition. (Displays zone 995)
 Police	Alerts Central Station of a police emergency. (Displays zone 999, default is silent)
 Medical	If programmed, alerts Central Station to other types of emergency. (Displays zone 996)

Configuring Programming (Continued)

Master User Options

Selecting the Menu icon on the Home Screen displays the User options list. Scroll up or down to view all the available options. The list provides access to the Installer and User configurable features. Entering the Installer or Master User Code is required to access the User Tools Menu. Additional information regarding these features can be found in the User Guide.

Selection		Function
	Menu	Provides access to menu
	Favorites	Provides access to selected Z-Wave devices for quick access
	Devices	Provides access to Z-Wave functions.
	Sensors	Provides access to Zone information and options
	Cameras	Provides access to built-in camera and Motion Viewer Captures (PROA7PLUS Only)
	Scenes	Provides access to view and run scenes
	Events	Provides access to system events
	Settings	Provides access to system settings
	Tools	Provides access to User Programming options (Installer or Master User Code required for access)

Configuring Programming (Continued)

Programming

Setting up the Communication Links

Note: Do not connect to a receptacle controlled by a switch. Allow two minutes for power-up.

1. Plug the power supply into a 24-hour, 110VAC non-switched outlet. Upon power-up, the “Please Standby!” message displays on the home screen.
2. Connect the Control Panel to the local router.
Tools → Master User Code → Wi-Fi Settings → Scan for Network OR Manually Connect to Network OR WPS → Enter required information OR follow prompts → OK

Registration, Programming, and Testing

Registration, Programming and Testing is conducted through AlarmNet 360 Programming Tool. On a laptop, PC or Smart Device, go to: www.alarmnet360.com or use the AlarmNet360 app.

Zone Response Type Definitions

During programming, you must assign a zone type to each zone, which defines the way the system responds to each zone in both the armed and disarmed states. Zone types are defined below.

Type	Function	Characteristics
Not Used	Used to program a zone that is not used.	<ul style="list-style-type: none"> • None
Door/Window Delay 1 (Entry/Exit 1)	Assigned to sensors or contacts on primary entry and exit doors.	<ul style="list-style-type: none"> • Entry delay #1 timing is programmable. • Exit delay is independently programmable. • Exit and entry delays when armed in Away, Stay or Night Stay mode. • No entry delay when armed in Stay or Away Instant modes. • Exit delay begins regardless of the arming mode selected.
Door/Window Delay 2 (Entry/Exit 2)	Assigned to sensors or contacts on secondary entry and exit doors that might be further from the keypad (typically used for a garage, loading dock, or basement door).	<ul style="list-style-type: none"> • Entry delay #2 timing is programmable. • Exit delay is independently programmable. • Instant alarm when armed in the Stay Instant or Away Instant mode. • Exit delay begins regardless of the arming mode selected.
Instant Perimeter (Perimeter)	Assigned to glass break sensors or contacts on exterior doors and windows	<ul style="list-style-type: none"> • Instant alarm when armed in any mode and during entry/exit delays.
Interior Stay/Away (Interior Follower)	Assigned to motion detectors covering an area (i.e.: foyer, lobby, or hallway) that must be passed during entry/exit delays to reach the keypad. Provides an instant alarm if the entry/exit zone is not violated first and protects an area in the event an intruder gains access through an unprotected area.	<ul style="list-style-type: none"> • Follows entry/exit delays when the delays are active. • Instant alarm when armed in Away or Away Instant mode. • Bypassed automatically when armed in Stay, Night Stay or Stay Instant mode.
Motion Away Standard Delay (Interior with Delay)	Assigned to motion detectors covering an area that includes an unprotected entry/exit door. Provides entry delay (using the programmed entry time), if tripped when the system is armed in the Away mode.	<ul style="list-style-type: none"> • Initiates Door/Window Delay #1 (with programmed entry time) when armed in the Away mode. • Provides Entry and exit delays when armed in the Away mode. • Instant alarm when armed in the Away Instant mode. • Bypassed when the system is armed in the Stay or Stay Instant mode. • Exit delay regardless of the arming mode selected.
Night Zone	Assigned to motion detectors covering an area such as a basement or garage that should not be passed through during the night. Provides an instant alarm if the entry/exit zone is not violated first and protects an area in the event an intruder gains access through an unprotected area. Assigned to motion detectors that are active in Night Stay mode.	<ul style="list-style-type: none"> • Follows entry/exit delays when the delays are active. • Instant alarm when armed in Away, Away Instant, or Night Stay mode. • Bypassed automatically when armed in Stay or Stay Instant mode.

Configuring Programming (Continued)

Zone Response Type Definitions (Continued)

Type	Function	Characteristics
Night Zone with Delay	Assigned to motion detectors covering an area such as a basement or garage that should not be passed through during the night. Provides an entry delay and protects an area in the event an intruder gains access through an unprotected area. Assigned to motion detectors that are active in Night Stay mode.	<ul style="list-style-type: none"> • Initiates Door/Window Delay #1 (with programmed entry time) when armed in the Away and Night Stay modes. • Instant alarm when armed in the Away Instant mode. • Bypassed in the Stay and Stay instant modes. • Provides Entry and exit delays when armed in Night Stay mode.
Day Zone (Day/Night)	Usually assigned to a zone that covers a sensitive area (i.e.: stock room, drug supply room, etc.) It can also be used on a sensor or contact in an area where immediate notification of an entry is desired.	<ul style="list-style-type: none"> • Instant alarm, when armed in Away, Stay, Night Stay, Stay Instant, or Away Instant mode. • Provides a latched trouble sounding from the keypad and, if desired, a Central Station report when disarmed (day).
24-hour Medical	Assigned to a personal emergency button or keypad panic. This zone type is always active.	<ul style="list-style-type: none"> • Instant alarm, when in the armed or disarmed state (always active). • Keypad sounding only, no bell output.
24-hour Auxiliary	Assigned to a zone containing a button for use in personal emergencies or to a zone containing monitoring devices (i.e.: water or temperature sensors, etc.).	<ul style="list-style-type: none"> • Sends a report to the Central Station and provides an alarm sound at the keypad. (There is no keypad timeout.)
Silent Burglary (Silent Burglary)	Assigned to sensors or contacts on exterior doors and windows where sirens are NOT desired.	<ul style="list-style-type: none"> • Instant alarm, with No audible indication when armed in the Away, Stay, Stay Instant, Night Stay, or Away Instant mode. • Report sent to the Central Station.
24-hour CO (Carbon Monoxide)	Assigned to any wireless zone with a carbon monoxide detector. This zone type is always active and cannot be bypassed.	<ul style="list-style-type: none"> • Bell output, keypads and detectors provide Temporal 4 Pulse when this zone type is alarmed on all partitions.
Trouble Beeps Only (24 Hour Trouble)	Used with Other response type.	<ul style="list-style-type: none"> • The system provides a trouble sound from the keypad (and a Central Station report, if desired).
24 Hour Fire (No Verification)	Assigned to any wireless zone used as a fire zone. This zone type is always active and cannot be bypassed.	<ul style="list-style-type: none"> • Bell output, keypads and detectors provide Temporal 3 Pulse when this zone type is alarmed on all partitions.
24 Hour Fire w/ Verification (Fire with Verification)	Assigned to any wireless zone used as a fire zone. Fire with verification is available with smoke detector device type. It cannot be used with heat detectors, combination heat/smoke detectors or fire pull stations. This zone type is always active and cannot be bypassed.	<ul style="list-style-type: none"> • Bell output, keypads and detectors provide Temporal 3 Pulse on all partitions when this zone type is alarmed and the alarm has been verified. • System verifies alarm by delaying reporting and alarm sounding for 30 seconds after alarm is detected. If the zone remains faulted after 30 seconds a fire alarm is provided. If any other fire zone is faulted during the 30 second delay window a fire alarm is immediately provided for that zone. An alarm for original fire zone is provided, if that zone is still faulted. If there are no fire alarms after the 30 second delay expires, the system opens a 60 second window. If any fire zone is faulted during that window a fire alarm is immediately provided for that zone.
Non-Reporting Output (No Alarm Response)	Assigned when no-alarm response is required. Used for activating scenes or Total Connect notifications.	<ul style="list-style-type: none"> • No reports to the Central Station. • No keypad sounding or chime and no display on screen. • System can still be armed.
Monitor Zone (Monitor)	Assigned to any wireless zone used for asset protection. Works as a dynamic monitor of a zone fault/trouble (not alarm).	<ul style="list-style-type: none"> • Reports to the Central Station, if enabled. • Fault/restores events are logged by the system. • No keypad sounding or chime. • System can still be armed.

Configuring Programming (Continued)

Zone Assignments

1-250	Wireless Protection Points	935	Panel Low Battery
280-407	Temperature Protection Points	936	Panel AC Loss
500-627	Keyfob Zones	950	Panel Communication Failure
628-659	BLE Zones	951	Communication Path Failure
800-831	Touchscreens/Touchpads	995	Fire Panic
900	Base Unit Tamper	996	Medical Panic
930	RF Jam SiX Series	998	Silent Panic
931	RF Jam 5800	999	Police Panic
934	Panel Battery Missing		

AN360 Programming Fields

Registration, Programming and Testing are conducted through the AlarmNet 360 Programming Tool. On a laptop, PC or Smart Device, go to: www.alarmnet360.com or use the AlarmNet360 app.

Field Name	Programming Options	Information
Editing AlarmNet Services		
Supervision	Daily	This is the supervision interval the communicator sends to AlarmNet. (Not to be confused with periodic test message).
Advanced Protection Logic	Enabled	<p>This communication enhancement provides added notification in the event of a panel compromise due to damaging or disabling attempts.</p> <p>Operation:</p> <ul style="list-style-type: none"> • System is armed • Delayed zone type (i.e.; Entry/Exit or Perimeter with Comm delay) has been faulted thereby starting the programmed delay. • Contact ID alarm message sent to AlarmNet and held. <ul style="list-style-type: none"> • Normal disarm: If the system is disarmed within the programmed entry delay + Comm delay (if programmed), no alarm message is sent to the Central Station. • No disarm: due to real alarm or panel compromise – If the system is not disarmed, the corresponding alarm message is transmitted from AlarmNet to the Central Station. • No communication response: In the event that a communicator does not respond to AlarmNet within 15 minutes of receiving an entry alarm message, a new contact ID message E316 Tamper is sent to the Central Station.
Video Alarm Verification	Enabled Disabled	Video Alarm Verification is integrated with the use of up to 8 PROINDMV indoor motion viewers and Total Connect 2.0

Configuring Programming (Continued)

Field Name	Programming Options	Information
Two-Way Voice	Enabled Disabled	<p>Allows the Central Station operator to listen and/or talk to individuals on premises following receipt of an alarm report over the Cellular or Wi-Fi Communicator. The two way voice session is initiated following any burg or panic report to the Central Station. The session is not initiated for Fire, CO or duress alarms. The Two-Way Voice feature is activated in the 'Listen Mode,' allowing the Central Station operator to evaluate the situation. After the session is initiated, the panel sirens and keypad sounds are discontinued and will remain off, even if the AAV session is ended before bell timeout. The panel begins transmitting a beep acknowledgement to the Central Station once per second. The beep alternates between two separate tones, and indicates the control is awaiting a command from the Central Station Operator. If no command is received within two minutes, the session times out and the call is terminated. A new Fire or CO alarm will terminate an AAV Session in order to report.</p> <p>AAV Rules for Panels with multiple communication paths:</p> <ol style="list-style-type: none"> a. The two-way Voice session will always utilize the alarm reporting path, unless Cellular only is selected in AlarmNet. b. Control Panels using Wi-Fi in addition to the Cellular Communicator have the option to select 'IP with Cell Rollover' or 'Cell Only' for 2-Way Voice path. If 'Cell Only' is selected Alarms will be sent over IP and the 2-Way voice session will go over Cell. If 'IP with Cell Rollover' is selected the panel will attempt to send the alarm report via Internet first. If Alarm Reporting is successful over Wi-Fi, then the two way Voice session is attempted over the Wi-Fi path, If for some reason the 2 Way Voice session "fails" to be established over the Wi-Fi path, the system will not attempt to use the cellular path for the two way Voice session. If alarm reporting over the Wi-Fi path fails, Alarm communication will automatically roll over to the cellular communication path and the resulting two-way voice session will also utilize the cell.
Editing Total Connect 2.0 Services		
Total Connect 2.0	Security Smart Security Smart Home	Select the desired Total Connect 2.0 package.
Video Service	None 7 Days 30 Days	
Video Doorbell Service	Enabled Disabled	

Configuring Programming (Continued)

Configuring Partitions and their Options

Field Name	Programming Options	Information
Select "P1: HOME PARTITION" OR "+ADD" to enable up to three additional partitions.		
Partition Name	Home Partition Partition-02 (If enabled) Partition-03 (If enabled) Partition-04 (If enabled)	Programmable and each partition should be given a name.
Description		
Partition Number	1 2 (If enabled) 3 (If enabled) 4 (If enabled)	Not programmable
Entry Delay 1	None 15 Seconds 30 Seconds 45 Seconds 60 Seconds 90 Seconds 2 Minutes 3 Minutes 4 Minutes	The time period in which you must disarm the system before an alarm condition occurs after activating a zone with response type entry/exit 1 or interior with delay assigned to it.
Entry Delay 2	None 15 Seconds 30 Seconds 45 Seconds 60 Seconds 90 Seconds 2 Minutes 3 Minutes 4 Minutes	The time period in which you must disarm the system before an alarm condition occurs after activating a zone with response type entry/exit 2 assigned to it. NOTE: Must be equal to or greater than Entry Delay 1
Exit Delay	45 Seconds 60 Seconds 90 Seconds 120 Seconds	The time period in which you have to exit the premises after arming the system to any mode.
Arm Ding	All RF None RF KeyFob RF Keypad	Confirmation of Arm and Disarm ding is provided when 'Arm Ding' via RF Fob or RF keypad is enabled in programming. The arm ding occurs after the exit delay has expired and the disarm ding occurs immediately after disarming with a keyfob or RF keypad, and is longer than arming confirmation ding.
Quick Arm	Enabled Disabled	Quick Arm allows arming the system without entering a user code. Press the Away, Stay, or Night Shield to arm.
Force Bypass	Enabled Disabled	When Force Bypass is enabled for a Partition in programming, the user is presented with the "BYPASS & ARM" button from the Home Screen when a zone is faulted. When pressed the panel will Bypass all Faulted zones and Arm when Arm Away, Home, or Night is pressed. When Force bypass is not enabled this option is not presented, instead faulted zones must be bypassed from the Sensors screen before the user will be presented with the Arm option.
Chime Mode	Enabled Disabled	This toggles the chime feature on or off for the selected partition. The "Chime" feature of the system is controlled by the end user with a toggle command (Settings->Chime). Whether or not a zone will chime is determined during initial programming or by the user in the "Sensors" section of the Tools Menu. There are 11 options to customize each zone for individual chime sounds.

Configuring Programming (Continued)

Field Name	Programming Options	Information
Quick Exit	Enabled Disabled	Quick Exit allows the user to press the Quick Exit button to restart the exit delay AFTER exit delay has expired only when the system is armed in HOME or NIGHT mode. This is to allow for someone to enter or exit without having to disarm the system. If Quick Exit is not enabled the Quick Exit button will not appear on the TouchScreen for the user.
Silent Exit	Enabled	Not programmable (always enabled) The Audible Exit warning can be disabled from any Touchscreen with each Arming by pressing 'Silent Exit' before pressing Arm Away. This will prevent the panel and remote keypads from giving Exit warning sounds for the entire duration of Exit time on this attempt. NOTE: When 'Silent Exit' is selected the panel will DOUBLE the exit delay time.
Power Up in previous	Enabled Disabled	Not programmable (always enabled) If the panel is powered completely down (AC and Backup Battery), it will return to its' previous state when power is restored. If the panel was armed custom with zones bypassed it will return to that same state on powerup.
Restart Exit Time	Enabled Disabled	Not programmable (always enabled) 'Exit Delay Restart' allows the user to press the 'Restart Timer' key any time DURING the exit delay after arming NIGHT, HOME or AWAY. to restart the Exit time. This can be done once during Away arming exit delay, and unlimited times during Home or Night arming exit delay. NOTE: When armed Away, if an entry/exit door is tripped a second time before exit delay time expires, the Exit delay time will always restart.
Display Exit Time	Enabled Disabled	Not programmable (always enabled) The Display will show the countdown of exit delay time in seconds on the screen of the Main Console and/or all keypads in that Partition.
Auto Stay Arming	Enabled Disabled	When the Partition is armed to Away and an entry/exit door was not violated within the programmed exit delay time, the Partition will automatically arm HOME at the end of Exit Delay. The panel will Auto Stay Arm when armed Away via: Main Panel or Keypad. The panel will NOT Auto Stay arm when armed Away via: Keyfob or Total Connect NOTE: If O/C reports are being sent, the system will report both Away and Stay. If the panel is armed Instant the Instant mode will remain once it changes to Auto Stay Arm. It will Arm in the Stay Instant mode.

Configuring Programming (Continued)

Adding Sensors

Field Name	Programming Options	Information
1. Select "Sensors"		
2. Click "Add Sensor"		
3. Select the Sensor Type	SiX™ or Motion Viewer 5800 or Takeover	
4. Learn the MAC Address	LEARN the MAC Address OR enter the serial number	For SiX™ or Motion Viewer select "Learn" and activate the sensor as instructed in the sensors installation guide and watch the led flash rapidly, and within 20 seconds go solid for 3 seconds indicating success For 5800 or Takeover manually enter the serial number or select "Learn" and activate the sensor. NOTE: Clicking "Learn" changes the display on the PROA7/PROA7PLUS to Installer Programming and acknowledges when a sensor is enrolled.
5. Partitions	Home Partition	Choose partition to assign the sensor.
6. Zone Number	Enter Zone Number	Defaults to the first available zone.
7. Zone Description 1	Enter Zone Description 1	Enter Zone Descriptor 1. Choose from the presented list for Spoken Words, or enter a custom word for display only.
8. Sensor Version	Not programmable	
9. Zone Description 2	Enter Zone Description 2	Enter Zone Descriptor 2. Choose from the presented list for Spoken Words, or enter a custom word for display only.
10. Device Type	Enter predefined word: Police, Door, Environmental, Flood, Medical, Other, Temperature, Window, Garage Door, Glass Break, and Motion Sensor	This populates based on the PROSiX transmitter type learned. Choose from the options presented, and corresponding Response type. The 'Device Type' chosen will be Spoken as the Third Zone Descriptor (unless Other is selected)
11. Loop Number/Service	1,2,3,4 (5800) Reed (PROSiX) External (PROSiX) 1 - 8 Contact (SiXC2W)	Each transmitter may support multiple services, such as PROSiXCOMBO, PROSiXSMOKE, PROSiXCT, PROSiXSHOCK, etc. Select the correct service/Loop for this zone. Select Add Service to use more services on the device.
12. Supervision	RF Supervised RF Unsupervised	
13. Chime	Disabled, Standard, Melody, Melody Long, Ascend, Ascend Long, Alert 1, Alert 2, Doorbell 1, Doorbell 2, Evolve	This option is not programmable for the following Device Types: Not Used, Smoke Detector, Heat Sensor, Carbon Monoxide Detector, Medical, Fire, Other, Temperature, Police
14. Response Type	Refer to Device/Response Type Matrix	Select the Zone Response type from the list presented based on the Device Type selected
15. Alarm Report	Enabled Disabled	Enables/Disables Alarm Report to be sent to Central Station
Pet Immunity	Enabled Disabled	Only available for SiX Motion Sensors
Arm Night	Enabled Disabled	Only available for any sensor with a Device Type of Motion Sensor or PROINDMV Motion Viewer
Sensitivity	Max Sensitivity Medium Sensitivity Low Sensitivity Lowest Sensitivity	Only Available for SiX Glass Break (SiXGB) and SiXSHOCK Sensors
One Go / All Go	Enabled Disabled	Only available for SiX Smoke/Heat/CO Devices

Configuring Programming (Continued)

PROINDMV Setup and Configuration

How it works

- The PROINDMV passive infrared only detects while the Partition is Armed.
- Once you enter the Sensor Walk test mode the PROINDMV PIR will start detecting and can be walk tested.
- When Armed, during Entry delay the PROINDMV holds any captures if tripped, and if not disarmed and an alarm occurs the captures are sent after the reporting delay expires. If disarmed before entry delay or reporting expires captures are discarded.
- After a capture the PROINDMV waits from 1.5 to 3 minutes before it will capture again. Maximum of 8 captures during an Armed state based on "Number of Alarm Reports" setting.

Configuration

Field Name	Programming Options	Information
1. Select "Sensors"		
2. Click "Add Sensor"		
3. Select the Sensor Type	SiX™ or Motion Viewer	
4. Learn the MAC Address *	LEARN the MAC Address	For SiX™ or Motion Viewer select "Learn" install the batteries in the motion viewer. The white LED will flash constantly as the device enrolls. NOTE: Clicking "Learn" changes the display on the PROA7/PROA7PLUS to Installer Programming and acknowledges when a sensor is enrolled.
5. Partitions	Home Partition	Choose partition to assign the sensor.
6. Zone Number	Enter Zone Number	Defaults to the first available zone.
7. Zone Description 1	Enter Zone Description 1	Enter Zone Descriptor 1. Choose from the presented list for Spoken Words, or enter a custom word for display only.
8. Zone Description 2	Enter Zone Description 2	Enter Zone Descriptor 2. Choose from the presented list for Spoken Words, or enter a custom word for display only.
9. Device Type	IMV	
10. Supervision	RF Supervised RF Unsupervised	
11. Response Type	Perimeter, Interior Follower, or Interior With Delay	
12. Alarm Report	Enabled Disabled	
13. Arm Night	Enabled Disabled	
14. Sensitivity	High Low	Select sensitivity setting of the PIR Motion sensor
15. Intrusion Type	Video Mode Intrusion Mode	Select Video Mode for 10-second video capture or Picture Mode for snap shot capture on Alarm.

Adding Keyfobs

Field Name	Programming Options	Information
1. Select "KeyFobs"		
2. Type	SiX™	
3. Learn the MAC Address	Learn MAC Address	Select Learn and when the panel is ready Press the top two keys on the keyfob simultaneously to start the enrollment process.
4. Choose the No. Of Keys	1 Button Key 2 Button Key 4 Button Key 6 Button Key 8 Button Key	Select Keyfob Type
5. Keyfob version	N/A	Displays the version of the keyfob
6. Available Starting Zone	500-624	Select the first Zone to assign the keyfob
7. Partition *	Home Partition	Select the Partition for the Keyfob
8. User Name	Select User	Select a User from the Programmed List
9. Button 0* *Number is variable depending on the Keyfob selected	24 Hour Silent 24 Hour Audible 24 Hour Auxiliary Fire No Verification Arm Stay Arm Away Disarm No Response	Program an action for each button to be used

Adding PROSiXLCDKP Keypads

Field Name	Programming Options	Information
1. Select "Keypads"		
2. Keypad Type	SiX™ Keypad	Not programmable. Select LEARN
3. MAC Address *	Keypad MAC Address	Press the "Learn" button to enroll the Keypad MAC Address. Follow the prompts on the keypad for proper enrollment steps.
4. Zone	800-831	
5. Zone Description 1		Enter Zone Description
6. Zone Description 2		Enter Zone Description
7. Keypad Version		Not programmable
8. Partition *	Home Partition	Select the Partition for the Keypad
9. Supervision Interval	15Min	Not programmable

Configuring Programming (Continued)

Configuring Settings

Field Name	Programming Options	Information
COMMUNICATOR		
Alarm Reporting Number	XX-XX-XXXX Enter: 2-digit City ID 2-digit CS ID 4-digit Subscriber ID	This is the 2-digit City ID, 2-digit Central Station ID, and 4-digit account number assigned to the customer by AlarmNet.
Supervision	Daily	Not programmable
Communication Path (internal Device)	Disabled Cellular Wi-Fi Wi-Fi and Cellular	
Old Alarm Time	10 Minutes 15 Minutes 30 Minutes 1 Hour 2 Hours 4 Hours 8 Hours 12 Hours 24 Hours	The old alarm time sets how long an undelivered alarm is retried for delivery to the Central Station. If the message is not validated, it is retried until the old alarm time is reached or the message is validated. Once Old Alarm Time has been exceeded, the radio will clear the message from its buffer and can notify the Control Panel via trouble notification.
Wi-Fi Fault Time	0-99 Minutes 60 Minutes	In the event the module detects a Wi-Fi communication path failure, enter the time delay (in minutes) before the module notifies the Control Panel with a trouble message. The Control Panel can then notify the Central Station over an alternate path.
Cellular Fault Time	0-99 Minutes 60 Minutes	In the event the module detects a Cellular communication path failure, enter the time delay (in minutes) before the module notifies the Control Panel with a trouble message. The Control Panel can then notify the Central Station over an alternate path.
Cellular 24Hr Test/UL864 Comm. Fire	Enabled Disabled	If enabled, sends a 24-hour test report message over cellular network.
Cellular Rollover	Enabled Disabled	If enabled, all messages (including AlarmNet network supervisory messages) are sent over the Cellular network in the event of an Internet failure. If disabled, all messages (except AlarmNet network supervisory messages) are sent automatically over the cellular network in the event of an Internet failure.
Use DHCP	Enabled Disabled	Not programmable
SYSTEM		
Alarm Report Delay	No Delay 15 Seconds 30 Seconds 45 Seconds	The Control Panel can delay the Central Station communication when a Burglary Alarm occurs. The delay applies to ALARM only, and will not apply to Fire, CO, or 24 hr panic zone types.
Burglary Alarm Sound	Enabled Disabled	When enabled, an audible alarm, which includes any zone type that would activate an external sounder, automatically increases the volume of the panel's internal sounder to 85dB. When disabled, audible alarms will sound from the panel at a low db sound, used for testing purposes. NOTE: External Sounders are not disabled when "Burg Alarm Sound" is disable.
Daylight Savings Time	Enabled Disabled	
Time Zone Offset	(UTC-5:00 Eastern Time (US & Canada)	
Software Version	XXXXXXXXXXXXXXXXXXXX	(Viewable Only)
Temperature Unit	Fahrenheit Celsius	Select display for Z-Wave Thermostat devices
Installer Language	English	
User Language	English	Select English, Spanish, French, or Portuguese

Configuring Programming (Continued)

Field Name	Programming Options	Information
Bluetooth Disarm	Enabled Disabled	Handsfree disarm - Supports up to 6 cell phones with Bluetooth. Each is assigned to a user to disarm a selected Partition based on proximity. Once the Entry delay begins, if the User's assigned Cell phone is marked as having left and returned, the Partition will Disarm and Log/Report the Disarm based on that User.
Enable Alexa	Enabled Disabled	Enables or disables Amazon Alexa Voice service with skills. Can be accessed via the Main Panel or PROWLTOUCH Wi-Fi keypads. NOTE: requires Wi-Fi
Backlight Timeout	No 30 Seconds 2 minutes 10 minutes 30 minutes	Sets the Control Panel backlight timeout period.
Lack of Usage Notify	Disabled 7 Days 27 Days 90 Days 180 Days	When enabled the system notifies the Central Station if an end user does not operate (arm/disarm) any partition in the security system within a specified amount of time. The time is reset per arm/disarm event. If triggered, the system will send a System Inactivity report of E654. There is no local annunciation indicating that the report has been sent to the CS.
RF Jam Log	Disabled RF Jam Log RF Jam Log and Report	Detects a condition that may impede proper RF reception (i.e., jamming or other RF interference). RF jamming occurs when something in our frequency range (345MHz and 2.4Ghz) has been transmitting for 20 seconds or longer. In any Armed/Disarmed state it causes the display to show a triangle with an exclamation point inside and the message RF Jam with a rapid trouble beeping that can be silenced with any key press. If trouble reporting is enabled a report to Central Monitoring Station (E344 RF Receiver Jam) will be sent. Once the trouble is cleared a Restore report will be sent (R344) if Trouble Restore reporting is enabled. The reported zones are 900 for 5800 Wireless, 905 for SiX Wireless and 906 for Wiselink. NOTE: The panel can still be Armed if an RF Jam condition exists.
Burglary Bell Timeout	No 4 Minutes 8 Minutes 12 Minutes 16 Minutes	Select the time for timeout of the Burglary Alarm Sounder.
Fire Bell Timeout	No 4 Minutes 8 Minutes 12 Minutes 16 Minutes	Select the time for timeout of the Fire Alarm Sounder.
Number of Reports (Swinger Shutdown)	1-6 2	Limits the number of messages sent per zone to the Central Station during an armed period, and how many times the local sounder will sound per zone per armed period. Also, limits Motion Viewer captures per Armed period
First Test Report Offset	6 Hours 12 Hours 18 Hours 24 Hours	Select the time for the first test report following power-up of the Control Panel.
Report Frequency	Never Every Day Every 7 Days Every 30 Days	Select the Report Frequency for the Periodic Test report.

Configuring Programming (Continued)

Field Name	Programming Options	Information
Panel Sync Delay Time	0 - 120 Minutes 3 Minutes	Select to set a delay time for the panel to sync back with AlarmNet 360 when a change is made locally.
REPORT SELECTION		
Arm Away	Enabled Disabled	Panel can report Open-Disarm/Close-Arm by user. If enabled all users will report via any path enabled. Reports User 0-96 and keyfobs also report the user number associated with the fob. Remote Arms or Power up Armed reports as User 0. Panel will report Open even if Closing report is not enabled.
Arm Stay	Enabled Disabled	
Disarm	Enabled Disabled	
Exit Error	Enabled Disabled	Not programmable (Viewable only) If the system is armed and an entry/exit or interior zone is still open after the exit delay time has expired, an alarm will sound and the entry delay timer is started. If the system is disarmed before the end of the entry delay, the alarm sounding will stop and no message will be sent to the Central Station. The system status bar will display "ALARM CANCELED" as well as Alarm and the descriptor of the zone or zones that were left open. If the system is not disarmed before the end of the entry delay mentioned above, and an entry/exit or interior zone is still open, an E374 (Exit Error Alarm) message will be sent to the Central Station, along with the Alarm on faulted zone. The message "Alarm, Exit Error" will display in the system status bar and the alarm sounding will continue until the system is disarmed (or timeout occurs).
Alarm Restore	Enabled Disabled	If enabled, all alarm restores are sent to the Central Station.
Alarm Cancel	Enabled Disabled	Alarm Cancel is sent upon a valid code being entered at a Partition following an alarm condition being reported.
Test	Enabled Disabled	Not programmable (Viewable only)
Test Restore	Enabled Disabled	Not programmable (Viewable only)
Low Battery	Enabled Disabled	If enabled, Low System battery report is sent to Central Station.
Low Battery Restore	Enabled Disabled	If enabled, Low System battery report restore is sent to Central Station.
RF Low Battery	Enabled Disabled	If enabled, RF Transmitter low battery report is sent to the Central Station.
RF Low Battery Restore	Enabled Disabled	If enabled, RF Transmitter low batter restore report is sent to the Central Station.
Recent Closing	Enabled Disabled	Not programmable (Viewable only) If enabled, a Recent Closing is sent to the Central Station. A Recent Closing condition is similar to an Exit Error condition, but occurs if a Burg Alarm occurs on the panel within two minutes of the exit delay expiring. If a recent closing condition occurs, both recent closing E459 by user, and the alarm report are sent. This alerts the Central Station that the Alarm may be due to User error.
Event Log Full	Enabled Disabled	If enabled, and once the event log reaches its 4,000 event capacity it sends an event log full event to Central Station.
Trouble	Enabled Disabled	If enabled, reports Troubles to the Central Station.
Trouble Restore	Enabled Disabled	If enabled, reports Trouble restore to the Central Station.
Bypass	Enabled Disabled	If enabled, reports all zone bypasses to the Central Station.
Bypass Restore	Enabled Disabled	If enabled, reports all zone bypass restores to the Central Station.
AC Loss	Enabled Disabled	If enabled, AC Loss reports to the Central Station.

Configuring Programming (Continued)

AC Loss Restore	Enabled Disabled	If enabled, AC Loss Restore reports are sent to the Central Station.
PANEL EVENT LOGS (Stored in Panel Memory)		
Log All Events	Enabled Disabled	Not programmable (Viewable only)
Log Alarm Events	Enabled Disabled	Not programmable (Viewable only)
Log Open/Close Events	Enabled Disabled	Not programmable (Viewable only)
Log Trouble Events	Enabled Disabled	Not programmable (Viewable only)
Log Non Security Events	Enabled Disabled	Not programmable (Viewable only)
Log Bypass Events	Enabled Disabled	Not programmable (Viewable only)

System Operation

Keypad/Touchscreen Operation

The keypads and touchscreens allow the user to arm and disarm the system, and perform other system functions, such as bypassing zones. Zone and system conditions (alarm, trouble, bypass) are displayed. When an alarm occurs, the Control Panel, along with any keypad and touchscreen sounds, and the zone(s) in alarm is displayed. Pressing any key silences the keypad sounder for 10 seconds (only once). Disarming the system silences all sounds. Once disarmed, any zones that were in an alarm condition during the armed period displays (memory of alarm). To clear alarm memory, simply repeat the disarm sequence. The Control Panel also features chime annunciation, and three Emergency Panic keys / icons for fire, police, and medical / personal emergency alarms. These keys can notify the Central Station of an alarm condition, if that service is connected.

PROSIXLCDKP Wireless Alpha Keypad Displays and Operation

The PROSIXLCDKP Wireless Alpha Keypad provides 2 lines with 16 characters per line allowing it to display programmed zone descriptors and full system messages, including the keypad's partition number indicated in the upper left corner.

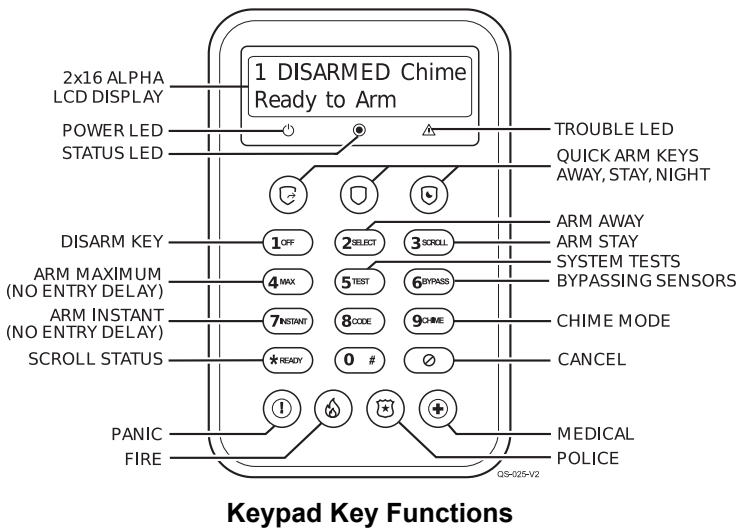

LED	Status	Meaning
 POWER	Red - Steady	No AC power is present and battery is very low.
	Green - Steady	AC power is present
	Green - Flashing	No AC is present and unit is operating on battery power
	Red - Flashing	No AC power is present and battery is low.
	Amber- Steady	Battery is charging
 STATUS	Off	System/Partition is Not Ready to Arm OR in Programming Mode
	Red - Steady	System/Partition is Armed
	Green - Steady	System/Partition is Ready to Arm
	Red - Flashing	Alarm detected OR Alarm in memory
 TROUBLE	Off	System is in Programming mode OR no troubles present
	Red - Steady	System trouble is present
	Red - Flashing	Device trouble is present

Keypad Menu Mode

This mode displays keypad programmed information and provides access to Default, Reset, LCD Brightness and Backlight options. Access the menu mode by holding the (3 SCROLL) key for 2 seconds. Press (3 SCROLL) key to scroll or the (* READY) key to exit. This mode exits after 1 minute of no keypad activity. See below for settings and options.

Display	Meaning / Option
App: Boot:	Displays the keypad's current App and Boot versions
RF6:	Displays the keypad's SiX software version and the keypad MAC ID
Default Keypad	Prompts to Default Keypad. (2 SELECT) = CONFIRM to remove keypad from Control Panel. NOTE: If the keypad is repowered within 24 hours, it attempts to re-pair with the Control Panel. After 24 hours, it needs to be re-enrolled.
Partition= Keypad ID=	Displays Partition assignment and Keypad ID programmed in the Control Panel.
Reset Keypad	Prompts to Reset Keypad. (2 SELECT) = CONFIRM (restart)
LCD Brightness	Prompts to change LCD brightness. (2 SELECT) toggles from Low, Medium, and High
Backlight Adjust	Press (2 SELECT) to cycle through options for: Always Off / ON, After 1, 5, or 15 minutes
A: None B: None	(Future Use) (Future Use)

Keypad Supervision

All keypads are supervised; however, touchscreens are NOT supervised. If the system loses communications with a wireless keypad for 15 minutes, the system latches into a trouble condition. If a touchscreen loses wireless connection to the Control Panel, it displays a black screen with "Please Standby". This message clears and displays status once it reconnects.

System Operation (Continued)

PROWLTOUCH Touchscreen Displays and Operation

The PROWLTOUCH touchscreen duplicates the functions of the Control Panel and mirrors its displays.

Master User Options

Selecting the Menu icon on the PROWLTOUCH Home Screen display the User options list. The options and operations duplicate those of the Control Panel and provide access to the Installer and User configurable features. When entering the Tools menu, the Installer Code provides more options than the Master Code. Additional information regarding these features can be found in the full User Guide.

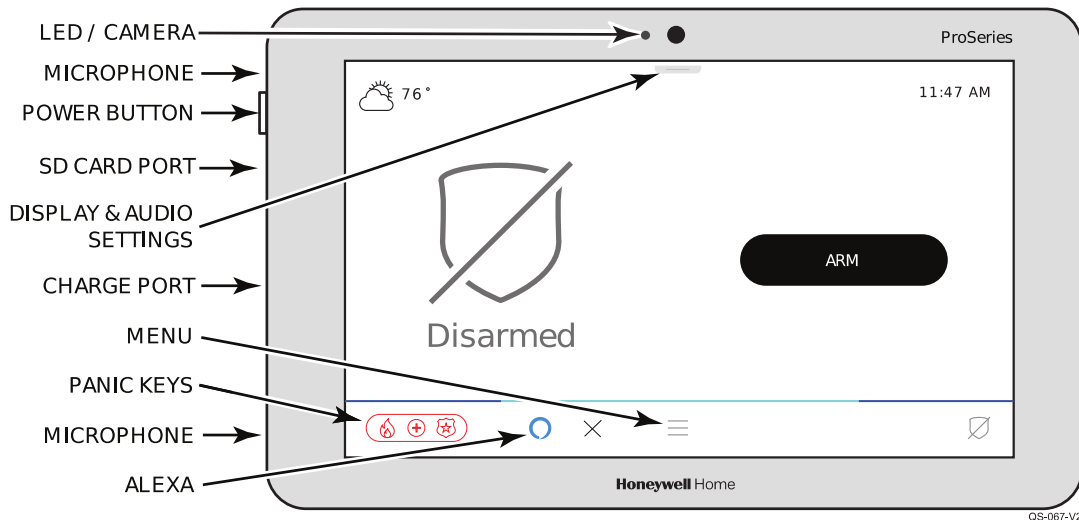

Status LED	Meaning
Red - Steady	System Armed
Red - Flashing	Alarm/Alarm Memory
Amber - Steady	System trouble
Amber - Flashing	Device trouble – System cannot be armed
Green - Steady	Ready to Arm
Green - Flashing	Device trouble - System can be armed
Green & Red Alternately Flashing	System is in Programming Mode
Off	Not ready to Arm

NOTE: The power button has 2 different functions:

- Press and Release toggles the screen off and on
- Press and Hold to display the options of Power Off or Restart.

System Operation (Continued)

Amazon Alexa

The Alexa feature (requires Wi-Fi) mimics the user's Alexa device (PROA7PLUS Only), allowing access to their Alexa account. Each PROWLTOUCH must be added to the user's Amazon account by following this procedure.

1. Select the  Settings option.
2. Select Voice Services.
3. Select Amazon Alexa (available only if Amazon Alexa has been enabled in panel programming).
4. Accept the End User License Agreement (EULA).
5. The system displays a link <https://amazon.com/us/code> and a 6-digit code.
6. From a PC, laptop, or smart phone, go to the link and sign into the user's Amazon account.
7. Enter the 6-digit code displayed on the touchscreen.
8. After a few moments, the touchscreen displays "Amazon Alexa Login. Login Successful".
9. The touchscreen shows as "WTS" in the Alexa app.
10. Select "OK".

NOTE: If the touchscreen is ever unpaired from a system, it resets the Alexa feature and it must be added back to the Amazon account using the above steps.

Events

The Events page displays everything in the system's Event Log. It provides a brief description and partition(s) the event occurred in.



Wi-Fi Settings







Wi-Fi settings let you connect to a wireless network via network scan, manual connection, or WPS. This connection is for the Control Panel to the router, not the PROWLTOUCH Touchscreen (if installed).





System Operation (Continued)



System Displays

The Control Panel and PROWLTOUCH Touchscreen displays the following icons along with specific zone status information (if applicable) to indicate system status. The icons associated with the programmed zones are displayed on the Zones screen.

NOTE: Only the SiX series wireless provide specific icons based on the type of transmitter is being used. E.g. The system knows that a SiXPIR motion detector is programmed, so the system assigns the following icon when faulted . Any 5800 wireless or hard wired zone is assigned the following icon, , no matter what type of transmitter or zone it is.

Icon	Function
	Disarmed
	Armed Away
	Armed Home
	Armed Night Stay
	Armed Custom
	Intrusion Alarm (displayed on red screen)

Icon	Function
	Battery level
	Wi-Fi Signal Strength
	Bluetooth Connected
	Signal Strength
	AC power connected

Icon	Function
	Fire Alarm
	Police Alarm
	Personal Alarm

System Operation (Continued)

Partitioning

Up to four partitions can be used in the Control Panel which allows different areas of the premises to work independently of each other; therefore, each can be armed and disarmed separately. Partition one is enabled by default, the other three partitions have to be enabled via AlarmNet 360 programming. Partition numbers display on the PROSIXLCDKP keypad. The control panel and PROWLTOUCH touchscreen display the partition name to indicate which partition is being viewed.

Goto Command

Control Panel and PROWLTOUCH

Goto commands are available on the Control Panel and PROWLTOUCH Touchscreen. Simply touch the partition drop down (located above the status icon) and select the partition name to log onto. The user is able to access only the partitions in which the security code is programmed. The display times out after 2-minutes of no keypad activity and automatically return to its home partition.

PROSIXLCDKP

Allows users to access another partition from the Control Panel or any keypad and operate that partition. Any security code that has been programmed into more than one partition can perform the Goto command by typing in the security code + * + single digit partition number ①, ②, ③ or ④. The user is able to access only the partitions in which the security code is programmed. The keypad times out after 30 seconds of no keypad activity and automatically return to its home partition.



IMPORTANT: Fire and CO Alarms display and sound on other partitions' keypads and sirens. The alarms can be silenced from each partitioned keypad, but alarm memory can only be cleared from the partition's keypad / touchscreen in which the alarm occurred.

System Clock

The system clock is retrieved from AlarmNet 360 automatically once the system is communicating. The clock can be viewed at the panel or any touchscreen. Even though the clock is automatically set, the time zone is selectable in panel programming.

Scheduling

Scheduling is accomplished via Total Connect 2.0 and available to the user once a Z-Wave automation device has been enrolled into the system. Up to 100 scenes can be programmed with various options of controlling Z-Wave Automation and auto arm / disarm.

Audio Alarm Verification (AAV) (Two-Way Voice)

If this feature is enabled, a hands-free voice session can take place after an alarm signal has been sent through the cellular or Wi-Fi network. The Central Station can initiate the voice session and talk to homeowner on site without the homeowner needing to touch anything.

NOTES:

- AAV works on all partitions
- An AAV session cannot be initiated for fire and CO alarms.
- Only the first 4 Touchscreens enrolled in the system can be used for Voice Stations along with the main Control Panel.
- Only one Touchscreen at a time can be used as a station during an AAV session, starting with the lowest Touchscreen enrolled in the system. (All stations cannot be active simultaneously.)

ATTENTION CENTRAL STATION OPERATOR:

Each session is automatically initiated in low-volume Listen mode. This means the operator can hear what is happening, on site, through all available touchscreen stations, but no one on site can hear the operator. Below is a list of commands that can be entered at any time during the session by the Central Station operator to control the voice session.

KEY	FUNCTION
1	Selects high-volume Talk Mode. Typically used with Key 3, Listen Mode, toggling back and forth.
2	Selects 2-Way Voice Mode allowing automatic switching between the site and the Central Station operator.
3	Selects Listen Mode. Typically used with Key 1, Talk Mode, toggling back and forth.
4	AAV session starts at the panel. Press 4 to move to each touchscreen in order and back to the panel.
7	Restarts the 5-minute voice session timeout. Sessions automatically terminate after 5 minutes unless 7 (or any other command) is entered.
*8n	Selects touchscreen station number where "n" is the station number.
99	Terminates the voice session. If this is not entered, the communication line stays connected for up to 5 minutes.

System Operation (Continued)

Security Codes

Up to 96 Security Codes (User Numbers) can be added, deleted, and partitioned to the Control Panel either through the keypads, touchscreens, or the AlarmNet 360 programming tool. There two Security Codes defaulted in the system which is the Installer Code, user number 01, and is set to 4112; the System Master Code, user number 02, and is set to 1234 in all 4 partitions. The Master Code can be used to enter additional 4-digit Security Codes via keypads and touchscreens while the system is in the Disarmed state. Security Codes cannot be added or changed while the partition is armed in any mode.

Programming Security Codes via Control Panel or Touchscreens

1. From the menu screen, select the  Setting option.
2. Select User Management and enter the Master Code. The system displays all current users.
3. Select a User from the displayed list to EDIT user information. The user's Name, User Code, Partition and Authority Level are now changeable. Select "SAVE" when editing is complete.
4. To delete a User, select the alongside the desired User, then select delete and enter Master Code.
5. After saving the user can edit the code to add Bluetooth Disarming and Z-Wave lock control. See "Automation" section for more information.

NOTES: Names can be applied to Security Codes so that the panel can report and log the name of the person(s) who are arming and disarming the Control Panel. These names can only be programmed via touchscreen or AlarmNet 360. If programmed in via AlarmNet 360, the names are reflected in the touchscreens.

Authority Levels

- **User** – Can arm, disarm, and bypass zones.
- **Arm Only** – Can arm, but cannot disarm.
- **Guest** – Can arm, but cannot disarm unless it was used to arm. Additionally, it cannot disarm if the system was armed via the Quick Arm feature.
- **Partition Master** – Can add and delete Security Codes just like the System Master Code, except it cannot change or delete the System Master Code.
- **Duress**: Can arm and disarm the control, but used in case of a duress situation because it sends a report (Contact ID E121 Duress) to the Central Station when entered.
- **Master** – Is User Number 02, defaulted to 1234 in all 4 partitions, and can add and delete any Security Code in the Control Panel. This Authority Level cannot be changed for user 02, nor can it be applied to any other user.
- **Installer** – Is User Number 01, defaulted to 4112, can arm disarm and bypass in all four partitions, but can only disarm if the code was used to arm the Control Panel.

Z-Wave Locks and User Code Push

The PROA7/PROA7PLUS Control Panel can push user codes (including Duress codes) out to compatible Z-wave locks, this provides a way to have the codes in the Lock and the Panel always match. When a user code is entered in the panel you can select 'Z-wave Lock Control'. If you select 'YES' for ANY User, then the panel will send those enabled codes out to the Lock, overwriting any codes in the lock so that it matches the panel. From this point the panel will keep its user codes in sync with the Lock.

NOTE: If this feature is used, codes can never be added directly to the Lock, they must be added to the panel to send to the Lock. Any codes added to Lock will be overwritten the next time the panel does a Sync.

Keypad User Code Lockout

This feature is always enabled. When a user has entered 5 incorrect Arm/Disarm commands within a 15-minute window and a valid command is not executed, the system stops processing additional numeric key presses in that Partition for 15 minutes (or until a valid keyfob is used to Disarm/Arm). The PROSIXLCD displays 'User Code Err, Keys Locked'. The PROWLTOUCH and Control Panel display, "Panel is Locked. Your panel has been temporarily locked due to multiple PIN attempts."

A "Wrong Code Entry" event is entered into the Event Log and a message (Event 461 "Wrong Code Entry") is transmitted to the Central Station with the Partition designation. Any numeric 0-9 key press during the lockout will restart the 15-minute window. When the lockout expires or the Lockout is cleared with a Keyfob, a Restore message is sent to the Central Station and entered the Event Log.

NOTES

- RF Fobs will work during a keypad lockout, and when used will clear the lockout. Duress codes will also not operate during a lockout.
- GoTo a Partition that is in Lockout will not function.
- Power down or reboot clears the Lockout.

System Operation (Continued)

Disarming / Cancelling an Alarm / Clearing Alarm Memory

- **Disarming during entry delay or alarm:** To disarm the system during the entry delay simply enter the 4-digit code on the keypad provided on the Control Panel or PROWLTOUCH. **NOTE:** for the PROSiXLCDKP type in a valid user code + ①.
- **Disarming during the exit delay:** To disarm during the exit delay press 'Cancel' in the bottom left of the screen. **NOTE:** for the PROSiXLCDKP type in a valid user code + ①.
- **Disarming while system is armed:** On the main control or PROWLTOUCH press 'Disarm' and enter the valid user code to disarm. **NOTE:** for the PROSiXLCDKP type in a valid user code + ①.
- **Clearing Alarm Memory:** To clear alarm memory on the main control or PROWLTOUCH press 'OK' on the Alarm Cancel window. **NOTE:** for the PROSiXLCDKP type in a valid user code + ①.

NOTE: If the alarm signal has been sent, the Cancel signal is sent once the first disarm is entered. If the Abort Window is enabled (30 seconds by default) and the system is disarmed from an alarm before the abort window expires, no signals are sent.









Rebooting the System

The Reboot function allows you to restart the system without having to power cycle it. This can be done from the Control Panel or the PROWLTOUCH Touchscreen or from AlarmNet 360. To reboot the system from the Control Panel or wireless touchscreen, perform the following:

1. Select  Tools and enter the Installer or Master / Partition Master Code.
2. Select "Reboot System".
3. A confirmation screen appears. Select "OK". The system restarts.

Panic Key/Icons

The system features three Emergency Panics for 24-hour silent, audible, fire or medical / personal alarms. The Emergency Panic buttons can be used to manually initiate their respective alarms and send their reports to the Central Station. These functions are identified by the system on the keypads and touchscreens as follows:

PROSiXLCDKP Keypad			There are 3 ways to activate an Emergency Panic alarm: 1. Press the Panic button and within 10 seconds press the desired Emergency button (Fire, Police, Medical / Personal). 2. Press desired Emergency button and within 10 seconds press the Panic button. 3. Press desired Emergency button and within 10 seconds press the same key. NOTE: Only the programmed Emergency keys light up when the Panic key is pressed. If the Emergency key does not light up, it is not programmed.
Zone	Panic		
995	Fire		
999	Police		
996	Medical/Personal		
PROA7/PROA7PLUS / PROWLTOUCH			To activate an Emergency Panic alarm: 1. Touch the panic icon on the bottom left hand corner of the screen. 2. Touch the desired Emergency Icon (Fire, Police, Medical / Personal, and silent). NOTE: Only the programmed Emergency Icons display.
Zone	Panic		
995	Fire		
996	Medical/Personal		
998	Silent		
999	Police		

Event Log (Events)

The control's event log is capable of recording and displaying up to 4,000 system events. These events are stored locally in the Control Panel in chronological order. When the maximum number of events is reached in the Event Log, the system overwrites the oldest event first. The event log can be viewed through the touchscreens by selecting the Events option from the Menu and entering the Master Code. Refer to the control's User Manual for additional information. The Events displayed vary depending upon the options that are programmed. The table below provides definitions of the events/codes that may be transmitted to the Central Station and/or displayed by the Control Panel. If the event code is preceded by an "E", it means the event is new and ongoing. If preceded by an "R", it means the event has been restored.

NOTE: In the unlikely condition that the backup battery becomes fully discharged when AC power is lost, a low battery condition occurs before completely discharging. Any system activity performed after the low battery notification is not saved in the event log. Additionally, the control reverts to the status condition as before the low battery notification.

System Operation (Continued)

Contact ID® Event Log Codes

CID Code	Definition	Event Log Display
100	Medical Alarm	Medical Alarm
110	Fire Alarm	Fire Alarm
120	Panic Alarm	Panic Alarm
121	Duress Alarm	Duress Alarm
122	Silent Alarm	Silent Alarm
123	Audible Alarm	Audible Alarm
131	Perimeter Alarm	Perimeter Alarm
132	Interior Alarm	Interior Alarm
134	Entry/Exit Alarm	Entry/Exit Alarm
135	Day/Night Alarm	Day / Night Alarm
137	Sensor Tamper Alarm	Tamper Alarm
143	Base Unit & Keypad Failure	Exp Module Failure
145	Base Unit & Keypad Tamper	Exp Module Tamper
146	Silent Burglary Alarm	Silent Burglary
150	24-Hour Non-Burglary Alarm	24 Hr Non-Burglary Alarm
162	Carbon Monoxide Alarm	CO Alarm
301	AC Loss Trouble	AC Loss
302	Low System Battery Trouble	System Low Battery
305	System Reset Trouble	System Reset
308	System shutdown	System shutdown
309	Battery Test Failure	Battery Test Fail
311	Battery Discharged or Not Installed	Battery Dead/Missing
316	System Tamper*	System Tamper
330	System Peripheral Trouble	System Peripheral Trouble
333	Expansion Module Failure	Exp Module Failure
338	Expansion Module Battery Failure	Exp Module Batt. Failure
341	Base Unit & Keypad Tamper Trouble	Cover Tamper
344	RF Jam Detected	RF Jam Detect
350	Communication Path Trouble	Comm. Path Trouble
353	Cellular Communication Transmitter Trouble	Cellular Comm. Trouble
354	Failure to Communicate Event	Fail to Communicate
372	Sensor Faulted	Sensor Faulted
373	Fire Trouble	Fire Trouble
374	Exit Error Alarm	Exit Error Alarm
378	Cross Zone Trouble	Cross Zone Trouble
380	Sensor Trouble	Sensor Trouble
381	Loss of RF Supervision Trouble,	Superv Loss-RF
383	Sensor Tamper Trouble	Sensor Tamper
384	RF Low Battery	RF Low Battery
385	Smoke Detector High Sensitivity Trouble	High Sense
386	Smoke Detector Low Sensitivity Trouble	Low Sense
394	Carbon Monoxide End Of Life	Carbon Monox End Of Life
401	Armed Away / Max by User	R401 - Arm Away E401 - Disarmed
406	Cancel	Cancel
407	System Armed/Disarmed Remotely	Armed/Disarmed Remotely
408	Quick Arm	Quick Arm
412	Download Okay	Download OK
414	Security Off	Security Off
441	Armed Stay / Instant by User	R441 - Arm Stay E441 - Disarmed from Stay

System Operation (Continued)

Contact ID® Event Log Codes (Continued)

CID Code	Definition	Event Log Display
459	Recent Close	Recent Closing
461	Wrong Code Entry	Wrong Code Entry
570	Zone/Sensor Bypass	Zone Bypass
571	Fire Zone Bypass	Fire Bypass
573	Burglary Zone Bypass	Burg Bypass
601	Manual Trigger Test Start	Man Trigger Test Start
602	Periodic Test Report	Periodic Test Rep
607	Walk Test Mode Start	Walk Test Start
627	Programming Mode Entry	Program Mode Entry
628	Programming Mode Exit	Program Mode Exit
654	System Inactivity	System Inactivity

Central Station Messages

The following Contact ID messages are generated by the Control Panel's cellular and Wi-Fi communicators for the conditions listed.

Alarm Condition	Alarm Code	Restore Code
Power On / Reset	E339 00 950	
Primary Communication Path Supervision	E350 C0 951	R350 C0 951
Secondary Communication Path Supervision	E350 C0 952	R350 C0 952
Communications Failure	E359 00 950	R359 00 950
Communications Failure Reminder	P359 00 950	
New Registration	E360 00 000	
Authorized Substitution Registration	E361 00 000	
Unauthorized Substitution Registration	E362 00 000	
Test	E601 00 000	

Confirming (Testing) the System

TO THE INSTALLER

Regular maintenance and inspection (at least annually) by the installer and frequent testing by the user are vital to continuous satisfactory operation of any alarm system. The installer should assume the responsibility of developing and offering a regular maintenance program to the user as well as acquainting the user with the proper operation and limitations of the alarm system and its component parts. Recommendations must be included for a specific program of frequent testing (at least weekly) to ensure the system's proper operation at all times.

Test Modes

The following test modes can be initiated by touchscreen command:



- Test Communicator
- Test Sensors (Walk Test)
- Normal Mode Test
- Reporting Test (AN360)



IMPORTANT: Notify the Central Station to put the account on test so they do not dispatch authorities.

Communications Tests

There are two ways to perform Communications Tests:

- From the Control Panel or the PROWLTOUCH Touchscreen, select  Tools and enter the Master Code or Partition Master Code then select System Tests. Select "Test Communicator" then select the desired Communication test.
 - Test Wi-Fi = Test the Signal Strength, Speed, and Access to the internet.
 - Test Cellular = Test the Sim Status, Signal Strength, and Access to the internet.
 - Test All = Test both at the same time.
- The system displays status for Cellular and Broadband (IP). Exit to the previous screen by selecting "<" or to the home security screen by selecting the small  icon.
- Communication Test cannot be performed from the PROSIXLCDKP.

NOTE: Communication Tests can only be initiated from partition 1.

Walk Test Mode

Alarm signals are not sent during Walk Test Mode.

1. Walk Test can be initiated from keypads and touchscreens.
2. From the Control Panel or the PROWLTOUCH Touchscreen, select  Tools and enter the Installer Code, Master Code or Partition Master Code then select System Tests > Test Sensors. Select "Start Test" to initiate the test mode.
3. From the PROSIXLCDKP Keypads, type in the Master Code or Partition Master Code + **5** + **1**. Each keypad emits a periodic beep ponce every minute as a reminder that it is still in Walk Test mode.
4. A pop-up displays, "Start Sensor Test. Please trigger sensors to see results." Select "OK" to continue or "Cancel" to quit.
5. Upon entering Walk Test, the Sounder and all keypads (excluding touchscreens) sound for 2 seconds.
6. Fault each zone (wireless keyfobs, doors, windows, motion detectors, etc.) and listen for the Chime beeps from the keypads and touchscreens. All protection zones and wireless keys Chime in Walk Test mode. The touchscreens also annunciate the zone's Voice Descriptor. **NOTE:** For SiX™ Wireless devices it displays the signal quality and the level of the battery, with the exception of the SiXFob. It only speaks the zone that it is programmed to (i.e. Zone 500).
7. To exit Walk Test Mode, select "End Test" or from the PROSIXLCD keypads type in the Installer code, Master Code, or Partition Master Code + **1**. **NOTE:** The test mode timeout and exit automatically after 4 hours.

Normal Mode Test

With the system in the disarmed state, check that all zones are physically restored with no faults on the system. If the system is "not ready" check the keypads or touchscreens for the faulted zone(s). Restore the faulted zone(s) so that the "Status" LED lights green. Fault and restore every sensor individually to assure that the zones fault and restore properly from the keypads and touchscreens.

Additionally, the Installer can got to Settings > Secondary Keypad to see the signal strength and battery life of all the SiX RF (PROSIXLCDKP) Keypads.

Testing the System (Continued)

Reporting Test

Through the Control Panel:

Alarm signals are sent to the Central Station during the following test.

1. Arm the system and activate zones. Keep in mind that the Swinger Shutdown is defaulted at 2 reports per zone per armed period (selectable 1-6), so only the first 2 signals are sent from that zone no matter how many times it was activated. From the Control Panel enter the 4-digit code to disarm the system on the displayed keypad. Next, press ok to clear alarm memory. If using the PROSiXLCDKP disarm the system twice (4 Digit Code + 1) to clear alarm memory and then re-arm the system to test additional zones. The Abort Window is set to 30 seconds (selectable None–45 seconds), which means the Control Panel waits this amount of time before sending the alarm signals after the alarm is initiated.

NOTE: Swinger Shutdown and Abort Window do not apply to 24hr zones such as Fire, Carbon Monoxide, and Panics.

2. Initiate each of the system's Emergency keys to ensure proper operation and reports to the Central Station. If the system has been programmed for silent emergency, there are no audible alarms or displays. A report is sent to the Central Station.
3. Notify the Central Station when all tests are complete and verify the reports with them.

Through AlarmNet 360:

1. Click on "Reporting Test"
2. Click on "New Reporting Test" the following message appears: "This Reporting Test ensures that the alarm signal from each sensor is reported to the Central Station. Please ensure the panel is armed before starting the test. Please Notify the Central Station that testing will be in progress prior to starting the reporting test. This will ensure the Central Station will not dispatch the authorities and notify the end users."
3. Check the box next to "I have informed the Central Station."
4. Click "Start Test" and a zone list appears
5. Activate each zone and when the proper signal is received a green check mark appears in the Reporting Test Status column.
6. When complete click "Stop Test"
7. Enter a name for the test and any notes desired.
8. Press "Done" and the following prompt displays "Alarm Report Test Saved. The test is complete. Now you can start monitoring the alarms."
9. Check the box next to "I have informed the Central Station"
10. Click "Finish".

Automation

Introduction to Automation

Your PROA7/PROA7PLUS is a Primary Z-Wave Controller which controls of a mesh network of wireless Z-Wave and Z-Wave Plus™ devices. This system may be used with all devices certified with the Z-Wave Plus certificate and should be compatible with such devices produced by other manufacturers. Z-Wave products are “included” into the Controller, so once they are programed, each device is assigned a unique address which allows them to communicate with each other and cannot be activated by a neighbor’s Z-Wave automation system. Z-Wave is a wireless protocol that many manufacturers can add to their products such as in-wall light switches, in-wall outlets/receptacles, plug in lamp/appliance modules, thermostats, door locks, garage door openers, and many more. These devices can be individually controlled locally from the Control Panel and Touchscreens, manually at each device, or remotely from the Total Connect 2.0 app. The PROA7/PROA7PLUS can control as many as 78 Z-Wave devices, which are sold separately. Every device is enrolled into the system differently and some are more difficult than others. We highly recommend hiring a professional to install devices such as thermostats, in-wall switches, receptacles, and door locks. Other devices such as plug-in lamp modules can be easily added to your automation system, typically by the push of a button. Z-Wave home control networks are designed to work properly alongside wireless security sensors, Wi-Fi, Bluetooth and other wireless devices. Some 900MHz wireless devices such as baby cams, wireless video devices and older cordless phones may cause interference and limit Z-Wave functionality.

Z-Wave Range

The PROA7/PROA7PLUS security system complies with the Z-Wave Plus standard of open-air, line of sight transmission distances of 500 feet. Actual performance in a home depends on the number of walls between the Control Panel and the destination device, the type of construction and the number of Z-Wave devices installed in the Z-Wave network.

- Each wall or obstacle between the remote and the destination device can reduce the maximum range of 500 feet by approximately 25-30%. Refrigerators, large TV’s, mirrors, etc. can reduce range by much more or completely block a signal.
- Brick, tile or concrete walls block more of the RF signal than walls made of wooden studs and drywall.
- Wall-mounted Z-Wave devices installed in metal junction boxes suffer a significant loss of range (approximately 20%) since the metal box blocks a large part of the RF signal.

Additional Z-Wave Information

- Z-Wave devices communicate with each other to make sure signals get from the Controller to the destination device, so the more devices in the Z-Wave network, the better they work and the more stable the network becomes. A signal can hop from device to device four times to get to the destination device. Battery operated devices, such as door locks, do not hop signals to other devices. This is to conserve battery power. Only constant powered devices can hop signals. The Controller learns the best path (from device to device) in the network to get a signal to the destination device.
- There can be one primary controller with multiple secondary controllers in a Z-Wave network. If you have a scenario where a different manufacturer’s controller needs to be primary, a “Shift Controller” command can be performed; which shifts the primary to secondary and secondary to primary, making the PROA7/PROA7PLUS the secondary controller. If this controller is being used as a secondary controller, use this procedure to reset this controller only if the network primary controller is missing or otherwise inoperable.
- When included as a secondary controller, this device can support Association command class Group 1 (aka Lifeline) up to 3 node ID’s.
- Each Z-Wave device knows when it is learned into a Z-Wave network. Once it is included into a network, it can not learn into a different one until it is excluded (removed) from the existing one.
- The system is not aware of door locks being enabled with any temporary user shutdown feature such as Vacation Mode. The system continues to lock/unlock a door if programmed to do so.
- Certain model of Z-Wave door locks with thumbturns allow a brief period in which the thumbturn can be operated manually before the device locks automatically. Locks of this type are not recommended for use with Scenes.
- Some Z-Wave devices may not communicate low-battery notifications. Please pay attention to low battery indications on individual devices and replace batteries when the notifications appear.
- The Control Panel issues a “Failed” status on Z-Wave devices when it does not receive a response back from that device. These devices are indicated by a  symbol on the Z-Wave Device Management menu. This can be due to range, interference, or the device itself. If the Control Panel receives a signal from the device, the “Failed” status clears.



IMPORTANT



Automation can ONLY be used for lifestyle enhancement. It must not be used for personal safety or property protection nor for use to control power to medical or life support equipment!





Z-Wave automation functionality is supplementary only and has not been evaluated by compliance agency.

Automation (Continued)

Accessing and Controlling Z-Wave Devices

Select , then scroll down and select “Devices” , and next choose “All Devices”. This populates a list of all the currently included (enrolled) Z-Wave devices. From here the devices can be controlled by choosing the appropriate desired action for each device.

Z-Wave Device Management Screen

Select , then scroll down and select “Devices” , and next choose “Z-Wave Device Management”. This screen has the following options:

- Enrolled Devices
- Inclusion Mode
- Exclusion Mode
- Network Wide Inclusion Mode
- Local Controller Info
- Shift Controller
- Update Network
- Remove All Failed Devices
- Reset the Controller



Enrolled Devices

This option provides a list of all Z-Wave device enrolled in the network and their status (online, offline, etc.).

Including (Adding) Automation Devices

Including, or adding, devices to the network can be done locally or using AN360 (www.alarmnet360.com or the AN360 App). The following procedure explains how to “Include” Z-Wave products along with explaining other Z-Wave features.

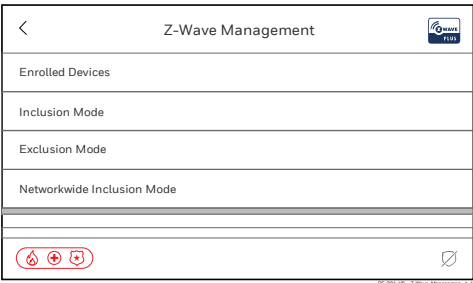
Note: If using older (300 series/First Gen) Z-Wave devices with the control there will be some loss of functionality. It is recommended that 500 series or higher devices be used to ensure for full functionality.

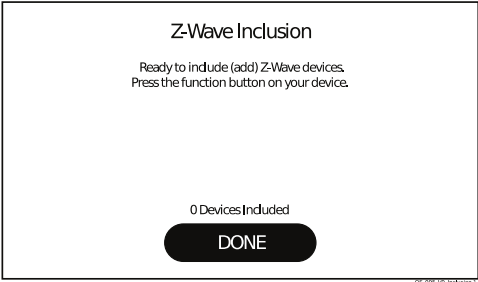

Touchscreen Display	Local	AN360
	<ol style="list-style-type: none"> 1. Select . 2. Scroll down and select “Devices” . 3. From the right, select “Z-Wave Management”. 4. A keypad displays. Enter the Master or Partition Master code. 5. Select “Inclusion Mode” if the device being added is very close to the Control Panel and can signal directly to it. Select “Network Wide Inclusion” if the device supports it, which is to be included through hopping signals through the Z-Wave network. <p>NOTE: The display shows the DSK PIN when the system is put into “Learn Mode”.</p> <ol style="list-style-type: none"> 6. The system is ready to include a device. Activate the device. <p>NOTES:</p> <ul style="list-style-type: none"> • Each type of Z-Wave device has its own unique way to initiate its inclusion process. Please refer to your devices instructions on how to include it into a Z-Wave Controller. • Some devices, such as door locks, may require to be within 3 feet of the Control Panel to be included into the network. Once included, it can be installed in the desired location. 	<ol style="list-style-type: none"> 1. Login to AN360 2. Select Z-Wave Devices on the left-hand side of the screen. 3. Select “Include Devices” and the screen displays “Enter to inclusion mode please wait” then “Ready to Include device. Press the function button on device.”
		

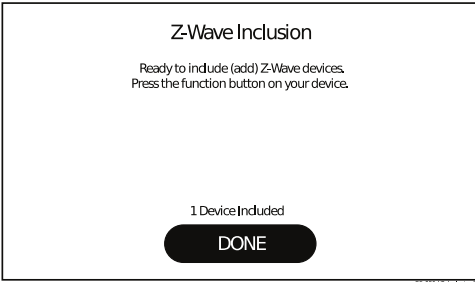
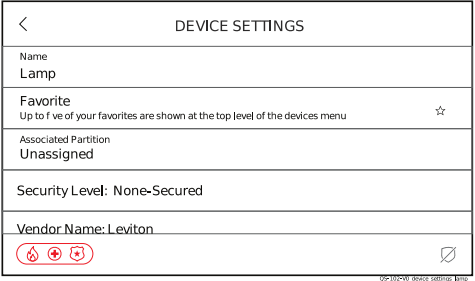
Automation (Continued)

Touchscreen Display	Local	AN360
 	<p>7. It indicates “1 Device Included”. Select DONE. If a device is not including, try the following:</p> <ul style="list-style-type: none"> • If possible, bring the Z-Wave device closer to the Control Panel. • Try going through the excluding procedure in the next section. If the device was tested in a different network and not excluded, it can not include into a different network until it receives an exclusion signal. Then try to include it again. <p>8. By default, when a device is included into the system, it has its own generic name such as “Device 1” or something similar. To rename the device, touch the device name on the left side.</p> <p>9. A keyboard displays, enter the desired name of the device. Then select SAVE.</p> <p>NOTE: Up to 40 characters can be used to create a name, however, only the first 25 characters are shown in the “Favorites” screen, which is covered later. The new device name is displayed. Select < to go back to the device’s full screen.</p>	<p>4. Include the next device, or if finished select “Abort” to return to the Z-Wave Devices screen.</p> <p>5. To change the device name, select the pencil icon to the right of the device.</p>

Excluding (Removing) Automation Devices

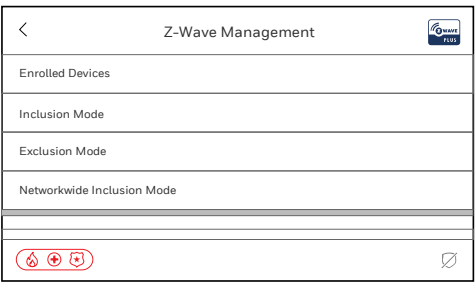
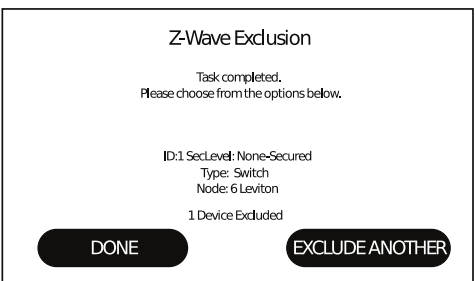
The following procedure explain how to exclude Z-Wave products from a Z-Wave network, so they can be used in a different network. This can also be used if you are having problems including a device in to a network, which allows a device to be included after being excluded.

Touchscreen Display	Local	AN360
 	<p>1. Select  then, scroll down and select “Devices” . From the right, select “Z-Wave Management”.</p> <p>2. Enter the Master or Partition Master code.</p> <p>3. Select “Exclusion Mode”.</p> <p>3. It prompts you to exclude Z-Wave device by pressing the function button on the device. Typically, you would exclude the device the same way it was included. See the instructions for that device for further details.</p> <p>4. It indicates “1 Device Excluded”. Select DONE or continue excluding more devices if needed.</p>	<p>1. Login to AN360</p> <p>2. Select Z-Wave Devices on the left-hand side of the screen.</p> <p>3. Select “Exclude Devices” and the screen displays “Enter to exclusion mode please wait” then “Ready to exclude device. Press the function button on device.”</p>

Automation (Continued)

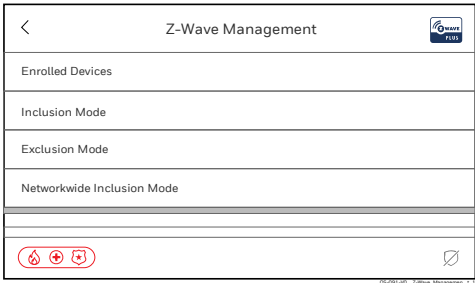
Touchscreen Display	Local	AN360
	<p>5. After you select DONE, the “Z-Wave Management” page is displayed. Select < to go back to the main screen.</p>	<p>4. Exclude the next device, or if finished select “Abort” to return to the Z-Wave Devices screen.</p>

Network Wide Inclusion

Network Wide Inclusion allows you to include devices through the network, not just within direct range of the controller (Control Panel).

Local Controller Info

Provides the controllers Name, Security Level, Vendor Name, NodeID, and Z-Wave Role.

Shift Controller

Shifts the PROA7/PROA7PLUS to secondary Controller in case you have a different manufacturer’s Controller that needs to be primary. A Z-Wave network can have one primary controller with multiple secondary controllers.

Update Network

Use this after adding, removing, or relocating a Z-Wave device. This allows the panel to remap signals to each device in the network.

Remove All Failed Devices

Any device that has failed can be removed from the Controller with this function. Use only when the device does not work in any location and has been proven bad.

Reset Controller

If the Control Panel is the primary controller for your network, resetting it results in the devices in your network to be orphaned and it is necessary after the reset to exclude and re-include all the devices in the network. This defaults the Z-Wave Controller in the system which removes all programmed Z-Wave devices, however, the devices do not receive an exclusion signal. So, when they need to be included, they need to be excluded first.

Alexa

If you want the Alexa feature (PROA&PLUS Only), it must be enabled in “Settings” through AN360 (www.alarmnet360.com). Each Touchscreen installed on your system, including the Control Panel, is considered a separate device to Alexa. The following setup procedure must be performed on the Control Panel and each Touchscreen as desired. In the devices section of your Alex app, the Control Panel is identified as “QSAIO” (All-In-One) while each Touchscreen is identified as “WTS” (Wireless Touchscreen).

The Control Panel and Touchscreens supports a variety of general Alexa skills:

- Weather Update
- Flash News Briefing
- Sports Updates
- Stock Updates
- Local Traffic & Drive Time
- Recipes/Meal Ideas/Wine Pairing
- Math Calculations
- Distance Calculations
- Timers
- Alarms
- To Do Lists
- Add Events to Calendar
- Shopping Lists
- Direct Shopping
- Reminders

NOTE: Phone Calls are NOT supported on the Control Panel or Touchscreens.







If using Total Connect 2.0, the account can be linked as a skill through your Alexa app. It is linked with your Total Connect 2.0 username and password. Once they are linked, perform the following commands through your Alexa devices:

- “Alexa, ask Total Connect “What is the status of my security system?””
- “Alexa, ask Total Connect, “Is my security system armed?””
- “Alexa, tell Total Connect to Arm.”
- “Alexa, tell Total Connect to Arm Away.”
- “Alexa, tell Total Connect to Arm Stay.”
- “Alexa, tell Total Connect to run bedtime”. (Bedtime can be a scene programmed to turn lights off and arm the system).
- Any programmed scene can be activated from Alexa, except for scenes that unlock doors or Disarm the system.

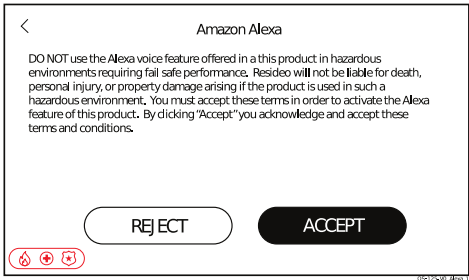
NOTES:

- Any Automation Scene programmed to run when the system is armed activates when you tell Alexa to arm your system.
- As a security feature, the system cannot be Disarmed using Alexa. Alexa is not associated with any user codes in your system. Disarming requires the entry of a valid 4-digit code.
- For multi-location Total Connect 2.0 accounts, only the first (single) location in Total Connect 2.0 is supported.
- For multi-partition Control Panels, Alexa is supported from any partition. Total Connect 2.0 scenes from Alexa is supported from partition one..

The following procedure explains how to setup Alexa on the Control Panel and Touchscreens.

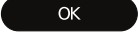
Step	Touchscreen Display	Description
		<ol style="list-style-type: none"> 1. Select  then, scroll down and select “Settings” . From the right, select “Voice Services.” 2. Select “Amazon Alexa”. 3. Enter the Master or Partition Master code. Read the End User License Agreement carefully. If you accept the agreement, select . If you do not agree, select .
		<ol style="list-style-type: none"> 4. Once you accept the license agreement, you are prompted to go to the amazon web site as described on this screen. Log into the Amazon account with your username and password. Enter the 6-digit code provided from this screen into Amazon site. 5. When the Amazon web site has indicated “Success! Your registration is complete.”. The screen automatically updates and indicates “Login Successful”. Select .

Automation (Continued)



6. Select **CLOSE**. Access this screen again by following steps 1-3.

If you **LOG OUT**, then Alexa is not available on the device from which you logged out. If you want to re-enable the device, repeat steps 1-6 again on the device from which you logged out from.

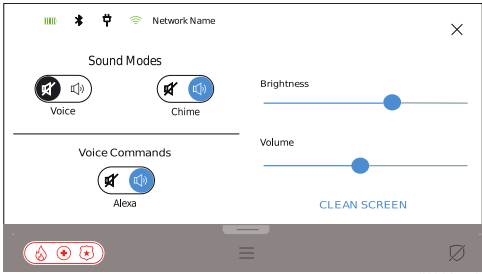

After the Alexa feature has been enabled on the Control Panel and each Touchscreen, the "Display & Audio Settings" screen displays a toggle button for Alexa Voice Commands on each enabled device. If Alexa is not enabled on a Touchscreen, Alexa Voice Commands are not displayed. When Alexa Voice Commands is enabled, it turns blue and Alexa can be used with all available features. If disabled, Alexa does not respond to any commands until it has been re-enabled.

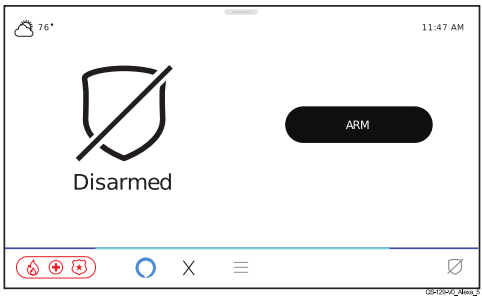

The Alexa icon is displayed in the bottom of the Home screen. Anytime you prompt "Alexa", the bottom bar above the Alexa Logo animates in accordance with the Alexa operation and an X displays next to the Alexa icon to stop any announcements. The bottom bar also flashes yellow when there is a notification and turn red if Alexa Voice Commands has been disabled.

Bluetooth Disarm

If the "Bluetooth Disarm" feature has been enabled (PROA7PLUS Only) in "Settings" in AN360 (www.alarmnet360.com), the system disarms as soon as a user's Bluetooth device is connected to the system. Multiple devices can be paired per user, but up to a maximum of six Bluetooth devices in the system. Each of the six Bluetooth devices can be setup in the Control Panel and each Touchscreen.

IMPORTANT SECURITY NOTICE

Your Bluetooth device is similar to your house keys. If lost or stolen, another person can compromise your security system. Immediately notify your Dealer of a lost or stolen Bluetooth device. Your Dealer can then disable Bluetooth programming from your security system.

Touchscreen Display

Description

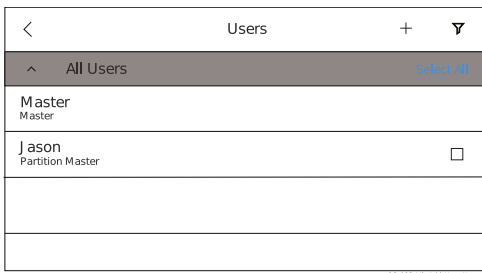

1. Select **≡** then, scroll down and select "Settings" . From the right, select "User Management".
2. A keypad is displayed. Enter the Master or Partition Master code.
3. Select the desired user from the list.

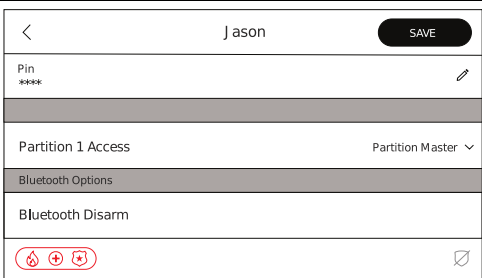

4. Scroll down in the user, then select "Bluetooth Disarm".
5. Select "PAIR".

Automation (Continued)

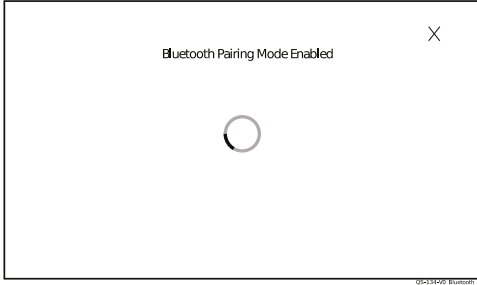

6. The Control Panel enters pairing mode. In the user's device, enable Bluetooth and look for the Control Panel or Touchscreen. It is labelled "ProSeries-XXXXXX", where X is the last 5 digits of its MAC address.

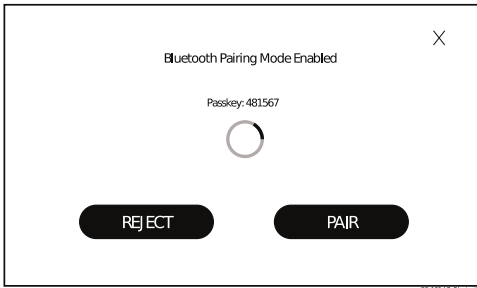

7. The Control Panel or Touchscreen provides a 6-digit passkey. You may need to enter this on your device or it may display automatically. Select "PAIR" on your device and select **PAIR** on the Control Panel or Touchscreen.

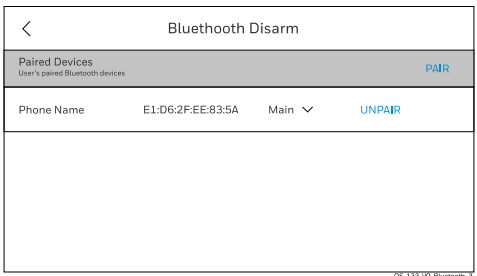

8. Once paired, the Control Panel displays the connected device, its MAC, partition it is to control and its connection status. You have the option to "UNPAIR" the user's device.

Regulatory Agency Statements

Federal Communications Commission (FCC) & ISED Statements

The user shall not make any changes or modifications to the equipment unless authorized by the Installation Instructions or User's Manual. Unauthorized changes or modifications could void the user's authority to operate the equipment.

CLASS B DIGITAL DEVICE STATEMENT

This equipment has been tested to FCC requirements and has been found acceptable for use. The FCC requires the following statement for your information:

This equipment generates and uses radio frequency energy and if not installed and used properly, that is, in strict accordance with the manufacturer's instructions, may cause interference to radio and television reception. It has been type tested and found to comply with the limits for a Class B computing device in accordance with the specifications in Part 15 of FCC Rules, which are designed to provide reasonable protection against such interference in a residential installation. However, there is no guarantee that interference will not occur in a particular installation. If this equipment does cause interference to radio or television reception, which can be determined by turning the equipment off and on, the user is encouraged to try to correct the interference by one or more of the following measures:

- If using an indoor antenna, replace it with a quality outdoor antenna.
- Reorient the receiving antenna until interference is reduced or eliminated.
- Move the radio or television receiver away from the receiver/control.
- Move the antenna leads away from any wire runs to the receiver/control.
- Plug the receiver/control into a different outlet so that it and the radio or television receiver are on different branch circuits.
- Consult the dealer or an experienced radio/TV technician for help.

This Class B digital apparatus complies with Canadian ICES-003.

Cet appareil numérique de la classe B est conforme à la norme NMB-003 du Canada.

FCC ISED Statement

This device complies with Part 15 of the FCC Rules, and ISED's license-exempt RSSs. Operation is subject to the following two conditions: (1) This device may not cause harmful interference, and (2) This device must accept any interference received, including interference that may cause undesired operation.

Cet appareil est conforme à la partie 15 des règles de la FCC et exempt de licence RSS ISED. Son fonctionnement est soumis aux conditions suivantes: (1) Cet appareil ne doit pas causer d'interférences nuisibles. (2) Cet appareil doit accepter toute interférence reçue y compris les interférences causant une réception indésirable.

Responsible Party / Issuer of Supplier's Declaration of Conformity: Honeywell International, 2 Corporate Center Drive., Melville, NY 11747, Ph: 516-577-2000.

Agency Notices

1. For Residential Burglar Alarm installations with line security, total exit delay time must not exceed 60 seconds. For Burglar Alarm installations without line security, total exit delay time must not exceed 120 seconds.
2. Periodic testing must be at least every 24 hours.
3. Remote downloading without an alarm company technician on-site (unattended downloading) is not permissible for ETL installations.
4. As SIA limits for delay of alarm reporting and sounding can exceed UL Standard limits for commercial and residential applications, the following requirements per UL681 are provided:
The maximum time that a control unit shall be programmed to delay the transmission of a signal to a remote monitoring location, or to delay the energizing of a local alarm sounding device to permit the alarm system user to enter and disarm the system, or to arm the system and exit shall not exceed:
 - a) 60 seconds for a system with standard line security or encrypted line security,
 - b) 120 seconds for a system without standard line security or encrypted line security, or
 - c) 120 seconds for a system that does not transmit an alarm signal to a remote monitoring location.

RF Exposure Warning

The antenna(s) used for this transmitter must be installed to provide a separation distance of at least 7.8 in (20 cm) from all persons and must not be co-located or operated in conjunction with any other transmitter except in accordance with FCC and ISED multi-transmitter product procedures.



Mise en Garde

Exposition aux Fréquences Radio: La/les antenne(s) utilisée(s) pour cet émetteur doit/doivent être installée(s) à une distance de séparation d'au moins 20 cm (7,8 pouces) personne et ne pas être située(s) ni fonctionner parallèlement à tout autre transmetteur ou antenne, excepté en conformité avec les procédures de produit multi transmetteur FCC et ISEDs.

IMPORTANT NOTE ABOUT EXTERNAL ANTENNAS

If an external cellular radio antenna is used, the antenna may be installed or replaced ONLY by a professional installer.

To the Installer

PROLTE-A: The external antenna gain shall not exceed 6.63 dBi for 700MHz and 850MHz, 6.0 dBi for 1700MHz and 8.5 dBi for 1900MHz. Under no conditions may an antenna gain be used that would exceed the ERP and EIRP power limits as specified in FCC Parts 22H, 24E and 27.

PROLTE-V: The external antenna gain shall not exceed 6.94 dBi for 700MHz, 6.0 dBi for 1700MHz and 9.01 dBi for 1900MHz. Under no conditions may an antenna gain be used that would exceed the ERP and EIRP power limits as specified in FCC Parts 22H, 24E and 27.

PROLTE-CN: The external antenna gain shall not exceed 6.63 dBi for 700MHz and 850MHz, 6.0 dBi for 1700MHz and 8.51 dBi for 1900MHz. Under no conditions may an antenna gain be used that would exceed the ERP and EIRP power limits as specified IC RSS-130, RSS-132, RSS-133, and RSS-139.

WARNING
THE LIMITATIONS OF THIS ALARM SYSTEM

While this System is an advanced design security system, it does not offer guaranteed protection against burglary, fire or other emergency. Any alarm system, whether commercial or residential, is subject to compromise or failure to warn for a variety of reasons. For example:

- Intruders may gain access through unprotected openings or have the technical sophistication to bypass an alarm sensor or disconnect an alarm warning device.
- Intrusion detectors (e.g., passive infrared detectors), smoke detectors, and many other sensing devices will not work without power. Battery-operated devices will not work without batteries, with dead batteries, or if the batteries are not put in properly. Devices powered solely by AC will not work if their AC power supply is cut off for any reason, however briefly.
- Signals sent by wireless transmitters may be blocked or reflected by metal before they reach the alarm receiver. Even if the signal path has been recently checked during a weekly test, blockage can occur if a metal object is moved into the path.
- A user may not be able to reach a panic or emergency button quickly enough.
- While smoke detectors have played a key role in reducing residential fire deaths in the United States, they may not activate or provide early warning for a variety of reasons in as many as 35% of all fires, according to data published by the Federal Emergency Management Agency. Some of the reasons smoke detectors used in conjunction with this System may not work are as follows. Smoke detectors may have been improperly installed and positioned. Smoke detectors may not sense fires that start where smoke cannot reach the detectors, such as in chimneys, in walls, or roofs, or on the other side of closed doors. Smoke detectors also may not sense a fire on another level of a residence or building. A second floor detector, for example, may not sense a first floor or basement fire. Finally, smoke detectors have sensing limitations. No smoke detector can sense every kind of fire every time. In general, detectors may not always warn about fires caused by carelessness and safety hazards like smoking in bed, violent explosions, escaping gas, improper storage of flammable materials, overloaded electrical circuits, children playing with matches, or arson. Depending on the nature of the fire and/or location of the smoke detectors, the detector, even if it operates as anticipated, may not provide sufficient warning to allow all occupants to escape in time to prevent injury or death.
- Passive Infrared Motion Detectors can only detect intrusion within the designed ranges as diagrammed in their installation manual. Passive Infrared Detectors do not provide volumetric area protection. They do create multiple beams of protection, and intrusion can only be detected in unobstructed areas covered by those beams. They cannot detect motion or intrusion that takes place behind walls, ceilings, floors, closed doors, glass partitions, glass doors, or windows. Mechanical tampering, masking, painting or spraying of any material on the mirrors, windows or any part of the optical system can reduce their detection ability. Passive Infrared Detectors sense changes in temperature; however, as the ambient temperature of the protected area approaches the temperature range of 90° to 105°F (32° to 40°C), the detection performance can decrease.
- Alarm warning devices such as sirens, bells or horns may not alert people or wake up sleepers if they are located on the other side of closed or partly open doors. If warning devices are located on a different level of the residence from the bedrooms, then they are less likely to waken or alert people inside the bedrooms. Even persons who are awake may not hear the warning if the alarm is muffled by noise from a stereo, radio, air conditioner or other appliance, or by passing traffic. Finally, alarm warning devices, however loud, may not warn hearing-impaired people.
- Telephone lines needed to transmit alarm signals from a premises to a central monitoring station may be out of service or temporarily out of service. Telephone lines are also subject to compromise by sophisticated intruders.
- Even if the system responds to the emergency as intended, however, occupants may have insufficient time to protect themselves from the emergency situation. In the case of a monitored alarm system, authorities may not respond appropriately.
- This equipment, like other electrical devices, is subject to component failure. Even though this equipment is designed to last as long as 10 years, the electronic components could fail at any time.

The most common cause of an alarm system not functioning when an intrusion or fire occurs is inadequate maintenance. This alarm system should be tested weekly to make sure all sensors and transmitters are working properly. The security keypad (and remote keypad) should be tested as well.

Wireless transmitters (used in some systems) are designed to provide long battery life under normal operating conditions. Longevity of batteries may be as much as 4 to 7 years, depending on the environment, usage, and the specific wireless device being used. External factors such as humidity, high or low temperatures, as well as large swings in temperature, may all reduce the actual battery life in a given installation. This wireless system, however, can identify a true low battery situation, thus allowing time to arrange a change of battery to maintain protection for that given point within the system.

Installing an alarm system may make the owner eligible for a lower insurance rate, but an alarm system is not a substitute for insurance. Homeowners, property owners and renters should continue to act prudently in protecting themselves and continue to insure their lives and property.

We continue to develop new and improved protection devices. Users of alarm systems owe it to themselves and their loved ones to learn about these developments.

Warning: this unit includes an alarm verification feature that will result in a delay of the system alarm signal from the indicated circuits. The total delay (control unit plus smoke detectors) shall not exceed 60 seconds. No other smoke detector shall be connected to these circuits unless approved by the local authority having jurisdiction.

Avertissement: Cette unité peut être programmée pour utiliser une fonction de vérification d'alarme d'incendie qui entraîne un délai dans la signalisation des alarmes provenant des circuits dédiés à l'incendie. Le délai total (unité de commande et détecteurs de fumée) ne doit pas dépasser 60 secondes. Aucun autre détecteur de fumée ne doit être raccordé à ces circuits sans l'approbation des autorités compétentes locales.

Note: Each protected circuit within this control is supervised.

Specifications

PROA7/PROA7PLUS Series Residential Burglar and Fire Alarm Control Panel

Physical:

Dimensions 7.875" (200mm) W x 5.75" (146mm) H x 1.0" (25.4mm) D

Electrical:

Voltage Input 110VAC, 60 Hz/9 Vdc from plug-in 2.5A power supply

Rechargeable Backup Battery Lithium-ion battery pack rated at 3.6/4.2V, 7500 mAH

Communication:

Formats Supported 4-digit Contact ID® Reporting

SIA Quick Reference Guide

Programming Section	Feature	Range	Shipping Default	SIA Requirement
AN360 Programming Fields				
REPORTER/ REPORT SELECTION	Exit Error	Not selectable	Enabled	Enabled
	Recent Closing	Not selectable	Enabled	Enabled
	Alarm Cancel	Enabled or Disabled	Enabled	Enabled
SYSTEM	Number of Reports	1 to 6	2	2
	Alarm Report Delay (Abort Window)	15, 30 and 45 seconds	30 seconds	30 seconds*
PARTITIONS	Entry Delay # 1	None, 15, 30, 45, 60 and 90 seconds and 2, 3 or 4 minutes	30 seconds	30 seconds minimum
	Entry Delay # 2	None, 15, 30, 45, 60 and 90 seconds and 2, 3 or 4 minutes	30 seconds	30 seconds minimum
	Exit Delay	45, 60, 90 and 120 seconds	60 Seconds	45 seconds minimum
	Restart Exit Time	Enabled or Disabled	Enabled	Enabled
	Exit Warning	Not selectable	Enabled	Enabled
	Auto Stay Arming	Enabled or Disabled	Enabled	Enabled
	Cross Zone Delay	30 seconds and 2 minutes (in 30 second increments), 3 minutes and 4 minutes	None (Disabled)	Enabled and two zones programmed
ZONES	Fire Alarms	Zone Type "Fire with Verification" must be selected for Fire Zone 95	Disabled	Disabled
User Guide				
User Functions/ User Access	Duress		Disabled	Disabled
System Functions/ Testing the System**	System Test	System tests provided as a User Function	n/a	n/a
	Communications	While the system is in Test mode, no alarm reports are sent to the Central Station	Disabled	Disabled

* Combined Entry Delay and Alarm Report Delay (Abort Window) should not exceed 1 minute.

** Refer to the User Guide for procedures on Testing the System.

NOTES

NOTES

Contacting Technical Support

To view support videos,
scan the QR code with a
smart device.



PLEASE, before you call the Product Support Group, be sure you:

- READ THE INSTRUCTIONS!
- Check all wiring connections.
- Determine that the power supply and/or backup battery are supplying proper voltages.
- Verify your programming information where applicable.
- Note the proper model number of this product, and the version level (if known) along with any documentation that came with the product.
- Note your customer number and/or company name.

Having this information handy makes it easier for us to serve you quickly and effectively.

THIS EQUIPMENT SHOULD BE INSTALLED IN ACCORDANCE WITH THE NATIONAL FIRE PROTECTION ASSOCIATION STANDARDS ANS/NFPA 70 NATIONAL ELECTRIC CODE AND NFPA 72 NATIONAL FIRE ALARM CODE, CHAPTER 2 (NATIONAL FIRE PROTECTION ASSOC., BATTERY MARCH PARK, QUINCY, MA 02169). PRINTED INFORMATION DESCRIBING PROPER INSTALLATION, EVACUATION PLANNING AND REPAIR SERVICE IS TO BE PROVIDED WITH THIS EQUIPMENT.

THIS DEVICE ALSO COMPLIES WITH THE FOLLOWING: CANADIAN STANDARDS ASSOCIATION (CSA) C22.1, CANADIAN ELECTRICAL CODE, PART 1, SAFETY STANDARD FOR ELECTRICAL INSTALLATIONS AND CAN/ULC-S540 INSTALLATION OF RESIDENTIAL FIRE WARNING SYSTEMS.

THIS DEVICE COMPLIES WITH PART 15 OF FCC RULES. OPERATION IS SUBJECT TO THE FOLLOWING TWO CONDITIONS: (1) THIS DEVICE MAY NOT CAUSE HARMFUL INTERFERENCE, AND (2) THIS DEVICE MUST ACCEPT ANY INTERFERENCE RECEIVED, INCLUDING INTERFERENCE THAT MAY CAUSE UNDESIRABLE OPERATION.

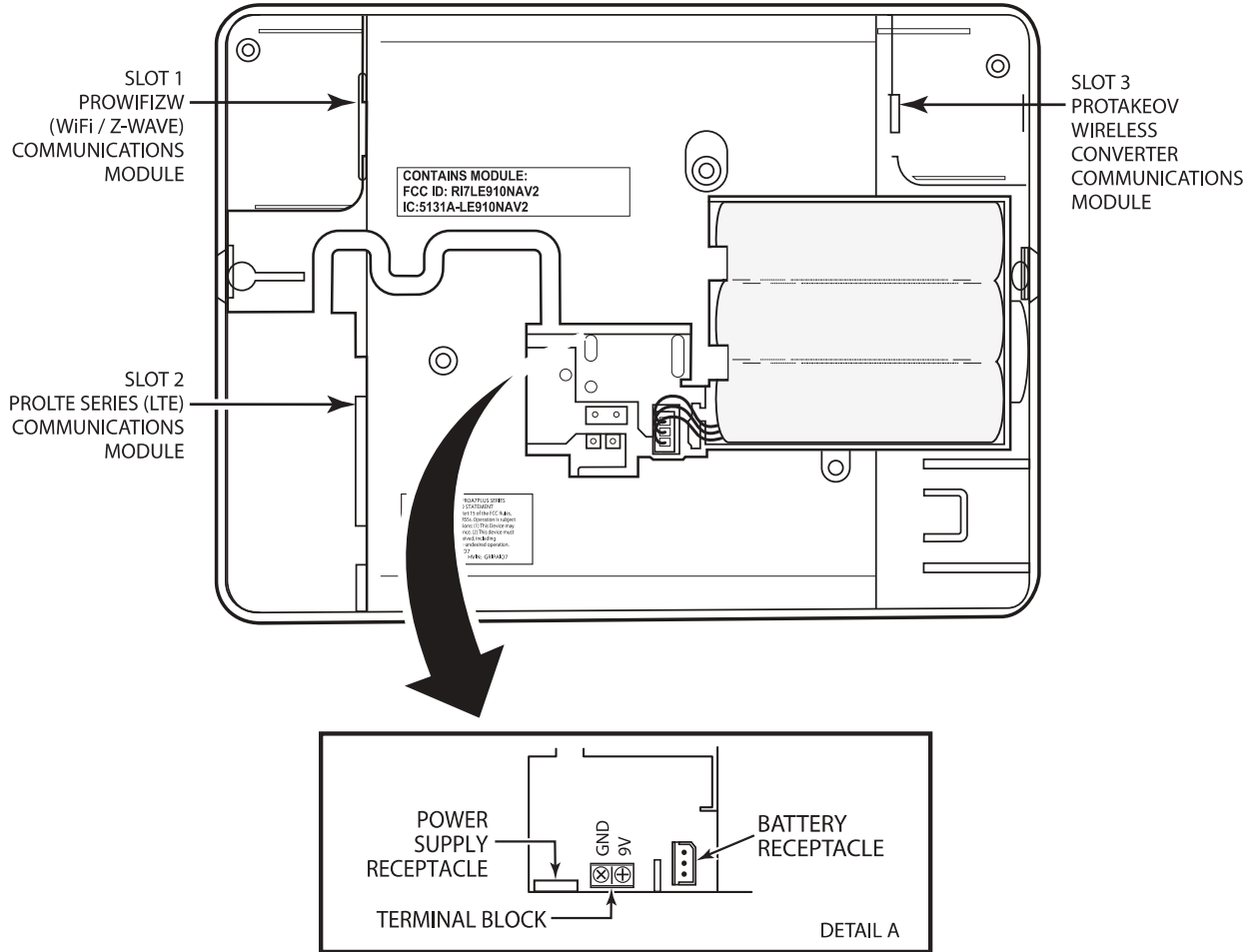

IMPORTANT NOTES ABOUT EXTERNAL ANTENNAS

PROLTE-A: The external antenna gain shall not exceed 6.63 dBi for 700MHz and 850MHz, 6.0 dBi for 1700MHz and 8.5 dBi for 1900MHz. Under no conditions may an antenna gain be used that would exceed the ERP and EIRP power limits as specified in FCC Parts 22H, 24E and 27.

PROLTE-V: The external antenna gain shall not exceed 6.94 dBi for 700MHz, 6.0 dBi for 1700MHz and 9.01 dBi for 1900MHz. Under no conditions may an antenna gain be used that would exceed the ERP and EIRP power limits as specified in FCC Parts 22H, 24E and 27.

PROLTE-CN: The external antenna gain shall not exceed 6.63 dBi for 700MHz and 850MHz, 6.0 dBi for 1700MHz and 8.51 dBi for 1900MHz. Under no conditions may an antenna gain be used that would exceed the ERP and EIRP power limits as specified IC RSS-130, RSS-132, RSS-133, and RSS-139

WEEKLY TESTING IS REQUIRED TO ENSURE PROPER OPERATION OF THIS SYSTEM

THE PROA7PLUS CONTROL IS COMPATIBLE WITH THE FOLLOWING INTEGRAL RECHARGEABLE BATTERY PACKS:

P/N 800-10186
REPLACE EVERY FOUR YEARS

Q5_AIO_S0C-V1

PROA7/PROA7PLUS RESIDENTIAL BURGLAR AND FIRE ALARM CONTROL PANEL SUMMARY OF CONNECTIONS

Notes: Connection of the fire alarm signal to a fire alarm headquarters or a Central Station shall be permitted with the approval of the local authority having jurisdiction. The burglar alarm signal shall not be connected to a police emergency number. The System must be checked by a qualified technician once every three years



The product should not be disposed of with other household waste. Check for the nearest authorized collection centers or authorized recyclers. The correct disposal of end-of-life equipment will help prevent potential negative consequences for the environment and human health.

Any attempt to reverse-engineer this device by decoding proprietary protocols, de-compiling firmware, or any similar actions is strictly prohibited.

For support, visit: www.resideo.com

For warranty information, visit: www.security.honeywellhome.com/warranty



resideo

www.resideo.com

Resideo Technologies, Inc
2 Corporate Center Drive, Suite 100
P.O. Box 9040, Melville, NY 11747

© 2020 Resideo Technologies, Inc. All rights reserved.
The Honeywell Home trademark is used under license from Honeywell International, Inc.
This product is manufactured by Resideo Technologies, Inc. and its affiliates.



800-25082A 10/20 Rev. A