

LP-PSOLT-90A Compact Power System
User's Guide

LinkedPro

Copyright by Linkedpro

All rights reserved.

The information in this document is subject to change without notice. No part of this document may in any form or by any means (electronic, mechanical, micro-copying, photocopying, recording or otherwise) be reproduced, stored in a retrieval system or transmitted without prior written permission from Qingdao Powtech Electronics Co., Ltd.

Safety Notice

In order to avoid accident, read the manual thoroughly before operation. The rules should be obey are not only the items “careful, attention, warning, danger” included in the manual, they are just complementarities of safety operation. So people who installs or operates the equipment should be trained before operation.

Contents

1 System Overview	4
1.1 System configuration	4
1.2 Operation principles.....	5
1.3 System Outlines.....	6
2 System Features and Specifications	7
2.1 System Features.....	7
2.2 System Specifications	7
2.3 Rectifier.....	9
2.4 Controller.....	10
3 Installation	12
4 Controller operation.....	166
4.1 Functions and features.....	16
4.2 Menu Structure.....	166
4.3 Alarm Message.....	188
4.3.1 Active Alarm.....	188
4.3.2 History Alarm.....	188
4.4 System Message	199
4.4.1 Rectifier Message	199
4.4.2 Battery Message	19
4.4.3 Software Version	20
4.5 System Control.....	20
4.6 Settings.....	22
4.6.1 Alarm Settings	23
4.6.2 Battery Settings.....	26
4.6.3 DC Limit Settings	27
4.6.4 System Parameter	29
4.6.5 Energy Saving	30
4.6.6 Battery Test	32
4.6.7 AC Parameter	33
4.6.8 Alarm summarize	333
5 Maintenance	344
6 Service information	355
6.1 Warranty	355
6.2 Servicecontact.....	355

1.1 System configuration

Fig1-1 System view

Power System is a 19" 3U rack-mount power system. It provides DC power by using four SR4850 rectifiers, the battery can be shut down by BLVD located in the shelf inside while DC voltage is less than the battery protection voltage .The system is supported by a single CAS-03D monitor that provides all control and operational conditions, as well as alarms and output parameter configuration. It operates from (-40 to +75), and it is designed for the harsh outside environment. System view is shown as fig1-1.

System configuration is shown

Table1-1 System configuration

Power	Input voltage	Output voltage	current	Accuracy	Part model
5400W	110Vac	53.5V	90A	±1%	SPS90-48
Distribution Section					
AC input	63A/2P×1, Class C AC surge				
AC output	N/A				
DC output	63A/1P×1,32A/1P×1, 16A/1P×1, 10A/1P×1, Class C DC surge				
Battery input	100A/1P×1				

1.2 Operation principles

When AC input power is in normal condition, the power system is in floating charge. A rectifier converts AC to DC to power the loads and floating-charge battery units. Rectifiers' output is in non master-slave mode to keep equilibrium output. The output voltage is adjusted automatically by the Controller for the battery floating charge.

When AC input is off, battery units will power the loads. If battery units are over-discharged, the controller will control the DC contactor to disconnect the battery units from the loads.

When AC input recover, rectifiers output DC current to loads, and at the same time charge the battery units with limited current. When voltage of battery units reaches equalizing value, charging current will be down slowly and it will keep the charge voltage till the charge current is less than change-over current value, then controller controls the rectifiers to enter the floating-charge mode.

When AC input power is in normal condition, the power system is in floating charge. A rectifier converts AC to DC to power the loads and floating-charge battery units. Rectifiers' output is in non master-slave mode to keep equilibrium output. The output voltage is adjusted automatically by the Controller for the battery floating charge.

When AC input is off, battery units will power the loads. If battery units are over-discharged, the controller will control the DC contactor to disconnect the battery units from the loads.

When AC input recover, rectifiers output DC current to loads, and at the same time charge the battery units with limited current. When voltage of battery units reaches equalizing value, charging current will be down slowly and it will keep the charge voltage till the charge current is less than change-over current value, then controller controls the rectifiers to enter the floating-charge mode.

1.3 System Outlines

W*D*H – (mm)	Weight – (kg)
482.6mm*370mm*132mm	16kg

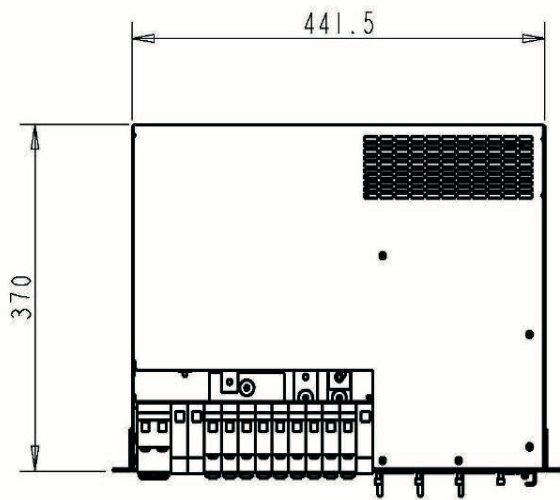
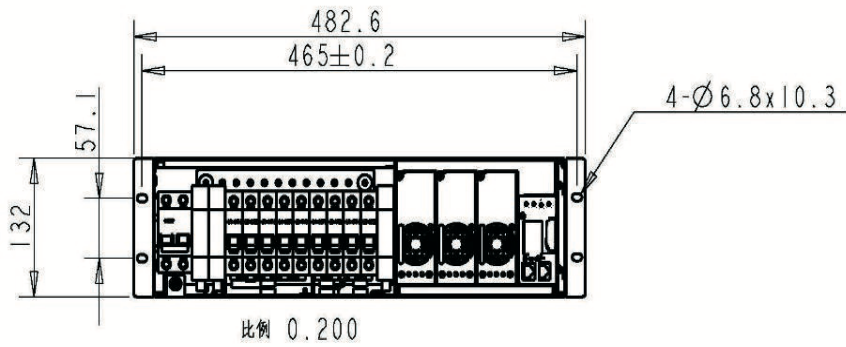

- (1) Universal AC input voltage range: 110 ~ 150VAC @100% loads.
- (2) High Power factor: 0.99@100% loads
- (3) High reliability
- (4) High power density
- (5) Hot-plug
- (6) Operation Temperature Range: -40°C- +75°C
- (7) 3U height shelf

2.2 System Specifications

Input Characteristics

Input Voltage	90-150Vac
Input Voltage (maximum)	150Vac
Frequency Range	45 -65Hz
Power Factor	≥0.99
Efficiency	≥92%
THD	<5%

Output Characteristics

Vo Set Point (min/typ/max)	42/53.5/58 (Vdc)
Io Output	90A @53.5Vdc
Rated Output Power	5400W
Output Noise (maximum)	<200 mV (peak to peak, bandwidth 20MHz)
Psophometric noise	<2 mV
Dynamic Response (maximum)	5%
Turn On Delay (maximum)	8 sec
Load Sharing (min/max)	-5/5 (%)

Output Characteristics

	Min	Typ	Max	Unit	Notes
Over Temperature protection			75	°C	
Input over voltage protection		300		Vac	
Input under voltage protection		80		Vac	
Output over voltage protection		59		Vdc	
Short circuit protection					No damage within long time

Environmental Characteristics

Parameter	Min	Typ	Max	Unit	Notes
Storage Temperature	-40		85	°C	
Operating Temperature (internal cooling)	-40		75	°C	-5 to +50 degree C with full performance, derating from 50C to 75C,
Humidity	5		95	%	Relative Humidity Non Condensing
Insulation Resistance	20M Ω				AC-Enclosure(500VDC)
	20M Ω				AC-DC(500VDC)
	20M Ω				DC-enclosure(500VDC)
Dielectric Strength			2121	Vdc	AC-Enclosure
			4242		AC-DC
			707		DC-enclosure

2.3 Rectifier

The rectifier is rated for 1800 Watt constant output power when operated at 110VAC above inputs,. This auto-sensing circuit enables each rectifier to automatically adjust its output to the available input voltage. The rectifier will provide up to 100% of rated power at 50) . As temperature increase from 50) to 75) , the internal thermal power limit circuit linearly decreases power. In the typical operating range, the rectifier has power factor greater than 0.99, total harmonic distortion less than 5%, and highest efficiency greater than 92%. Each hot-swappable rectifier has an integral multi-speed cooling fan and 3 LED status indicators.

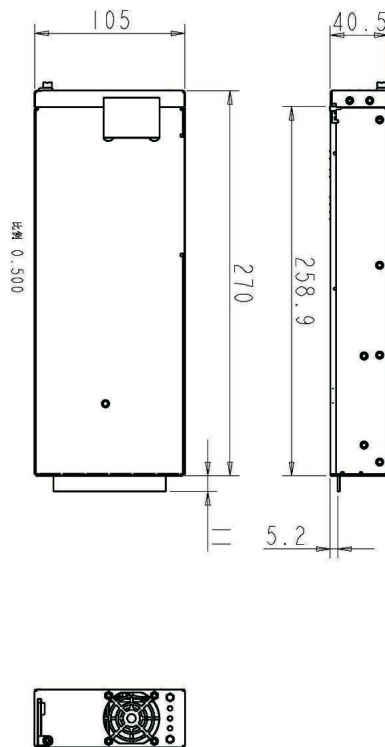

Table 6 Dimension and Weight

W*D*H – (mm)	Weight – (kg)
482.6mm*370mm*132mm	16kg

2.4 Controller

There are LCD display, LED indicators, keys, RS232 /LAN communication ports on the front panel of the monitor CAS-03D

Parameter measurement and monitoring	AC input voltage, DC output voltage, rectifier output current, charging and discharging current
Fault detection	AC input faults, DC output faults, Rectifier output current limiting, Module over hot, Fan failure, Battery output voltage low, Battery melt fuse failure
Parameter control	Charging current, Auto converting between equalizing and floating charge, Rectifier current limit, Module power On/Off, Primary and secondary power off. melt fuse failure
Battery management	Boost/Float change automatically Current limiting for equalizing charge,
Interface	LCD, English language, 4 key operation
Alarm warning	Sound, light, Dry contact outputs
Communication port	RS232/RS485/LAN
Power	DC48V / 0.5A

2.4 Controller

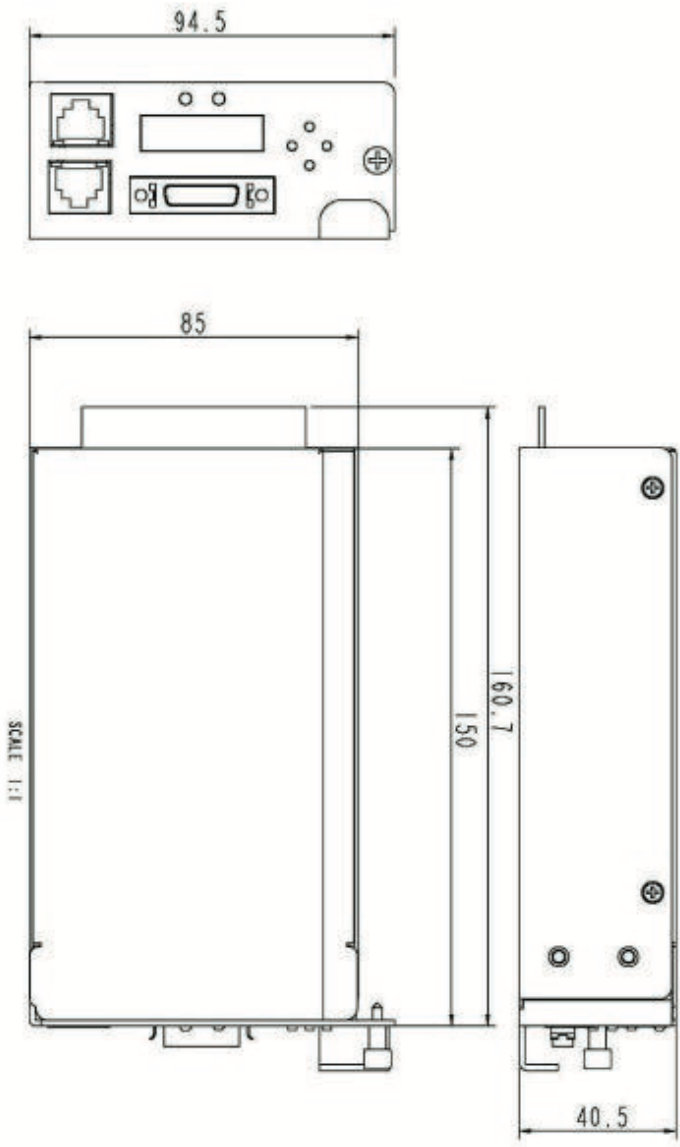

W*D*H – (mm)	Weight – (kg)
94.5*150*40.5 <0.6kg	16kg

Concerning the safety of yourself and this equipment, please follow the following installation procedures.

Warning: Making sure the AC circuit breaker and DC circuit breaker in “Off” position before installation.

3.1 Shelf installation in the cabinet

Inserting the empty housing into the system rack cabinet and screwing down securely.

3.2 Battery Connection

Connecting the battery cables securely with gaskets to the battery wiring connectors on the distribution panel on the front shelf.



Warning: It may damage the equipment if misconnect the “0” and “BAT-“ of the batteries.
 (“0V” will be connected to the 48V battery positive pole and the “BAT-” will be connected to 48V battery negative pole)

3.3 Load connection

Connecting the load positive cables securely with gaskets to copper bus connectors (0V) and the negative cables to the related breaker (-48V) on the distribution panel on the front shelf. Warning: It may damage the load equipment if misconnect the “0V” and “-48V” of the load.

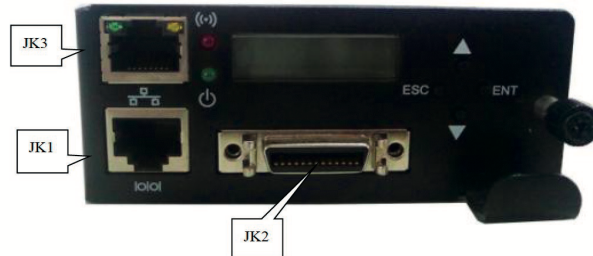

Fig.Front of Controller

Connector	Pin No	Definition	Note
JK1	1	A485	RS485+
	2	B485	RS485-
	3	TXD	RS232 TXD
	4	VPGND	RS232 GND
	5		
	6	RXD	RS232 RXD
	7	/	N/A
	8	/	N/A

Notice: In front of the controller, the pin number from left to right of JK1 is pin1 to pin8.

Table JK2 Definition

Connector	Pin No	Definition	Note
JK2(DB26)	1	SDI1-	Digital Input 1 negative
	2	SDI1+	Digital Input 1 positive
	3	SDI3-	Digital Input 3 negative
	4	SDI3+	Digital Input 3 positive
	5		N/A
	6	DO3C	Relay output 3 normal close
	7	DO3M	Relay output 3 common
	8	DO3O	Relay output 3 normal open
	9	/	N/A
	10	/	N/A

Connector	Pin No	Definition	Note
JK2(DB26)	11	DO1C	Relay output 1 normal close
	12	DO1M	Relay output 1 common
	13	DO1O	Relay output 1 normal open
	14	SDI2-	Digital Input 2 negative
	16	SDI2+	Digital Input 2 positive
	15	SDI4-	Digital Input 4 negative
	17	SDI4+	Digital Input 4 positive
	18	/	N/A
	19	/	N/A
	20	/	N/A
	21	DO4C	Relay output 4 normal close
	22	DO4M	Relay output 4 common
	23	DO4O	Relay output 4 normal open
	24	DO2C	Relay output 2 normal close
	25	DO2M	Relay output 2 common
	26	DO2O	Relay output 2 normal open

Notice: JK2 pins arrange

Position		Pin No	
Row 1st from right to left		1,3,5,7,9,11,13	
Row 2nd from right to left		2,4,6,8,10,12	
Row 3rd from right to left		15,17,19,21,23,25	
Row 4th from right to left		14,16,18,20,22,24,26	
Connector	Pin No	Definition	Note
JK3	8	LAN	Standard network port

3.6 After finish the above, make a through check and make sure all the cable connection correct.

3.7 Inserting all the modules including rectifiers into the housing and screwing down securely.

Warning: Making sure the AC circuit breaker and the power switch of the controller in “Off” position when inserting the rectifiers and AC unit.

4.1 Functions and features

(1) Electric parameters detection and measurement:

AC input voltage, DC output voltage, rectifiers output current, charge and discharge current of battery units, temperature of battery units.

(2) System failures detection

Problems and failures can be detected from: AC input, DC input, output current limitation of rectifiers, over temperature of rectifiers, cooling fans, lightning protection and surging protection, battery capacity, melt fuse of battery units and distribution.

(3) Electric parameters Control

Adjusting range of DC output voltage: 42V-58V

Limiting range of rectifier output current: 5A-55A @48V / 54.2A@53.5V

(4) Battery management

floating voltage switching: Manual /auto

Battery low voltage (LVD) protection

Battery charge mode selection: Equalizing charge mode with limited current, thermal compensation for floating charge, accumulative number indication of ampere-hours of battery discharge.

(5) Rectifier control:

Rectifier switch on/off

4.2 Menu Structure

You can get the main system messages including system voltage, load current, battery current and running status in the home page. Home page 1 will be displayed after started up. You may press key

“▼” to turn to home page 2 and 3. For more details, please refer to Fig4-1.

4.2 Menu Structure

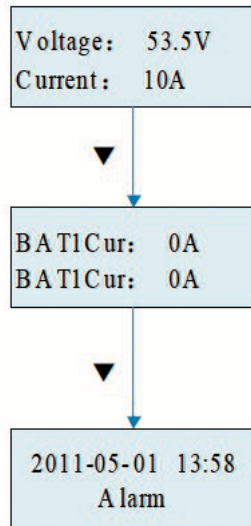

Fig4-1. Home Page

Three menu was used in CAS-03D controller, so you may look up the system messages and paramteres quickly. Press key “ENT” will turn to submenu and “ESC” to exit, “▲” and “▼” are used to select

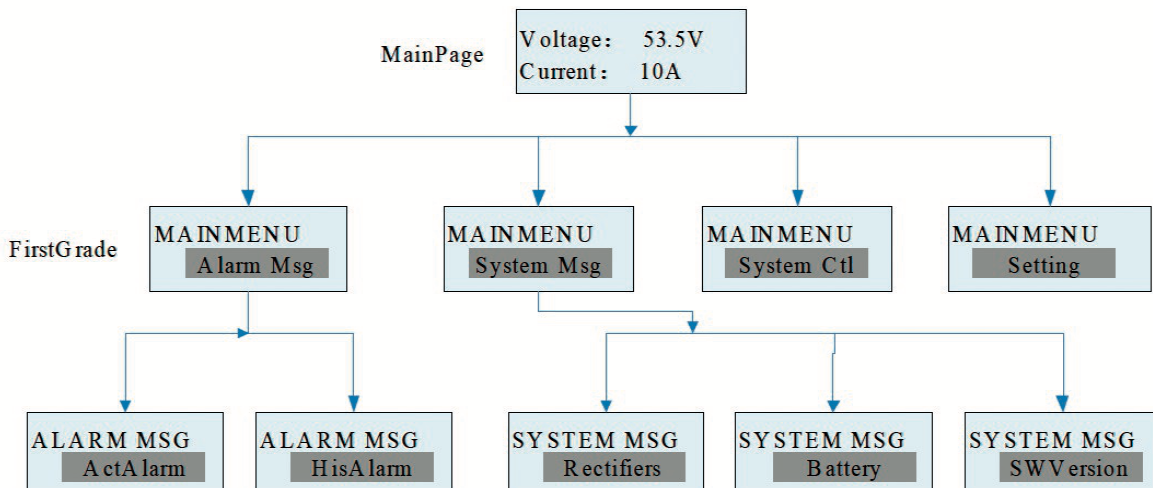

Fig4-2. Menu Structure3 Alarm Message

CAS-03D is able to save 64 pieces active alarms and 200 pieces history alarms. You may view these message by operating “Act Alarm” and “His Alarm” menu.

4.3.1 Active Alarm

When a fault happens in power system and the fault was set to be major or minor alarm level, controller will give an alarm with bright light and buzzer sound. You could check what's the fault name

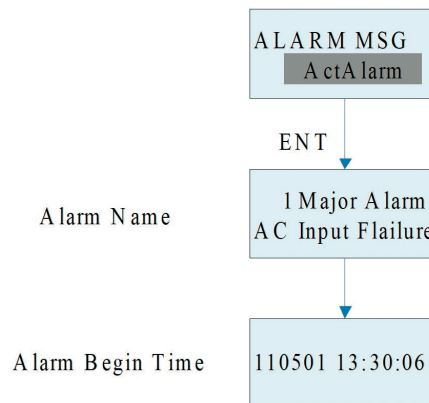

Fig4-3. Active Alarm

4.3.2 History Alarm

After the active alarm is gone, it will be changed to history alarm and saved in E2PROM. You may view when the alarm happened and ended by pressing into "His Alarm" menu. Operation is showed in Fig4-4.

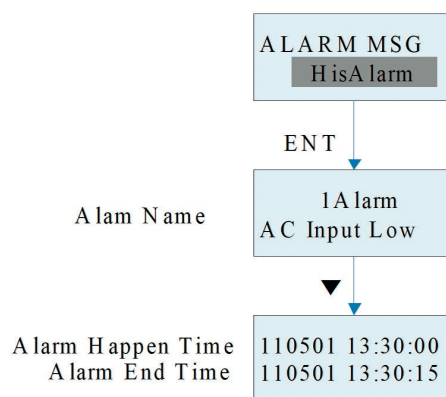

Fig4-4. History Alarm

4.4 System Message

Some important messages of the power system including rectifier messages, battery messages and software version may be viewed by operating "System Msg" menu.

4.4.1 Rectifier Message

You may view the rectifiers' messages including rectifier No., input voltage, output voltage, current

limit point, on-off status and limit status, by operating "Rectifiers" menu. Flow is shown in Fig4-5.

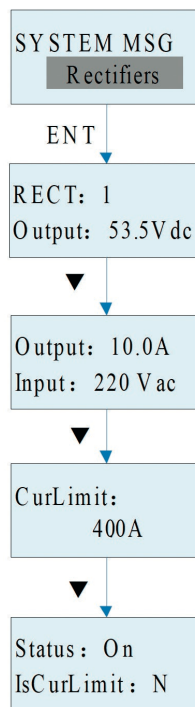

Fig4-5. Rectifier Message

4.4.2 Battery Message

You may view batteries' message including battery current, remain capacity, charge mode, battery temperature and ambient temperature by looking-over "Battery Msg" menu. Flow is shown in Fig4-6.

4.4.2 Battery Message

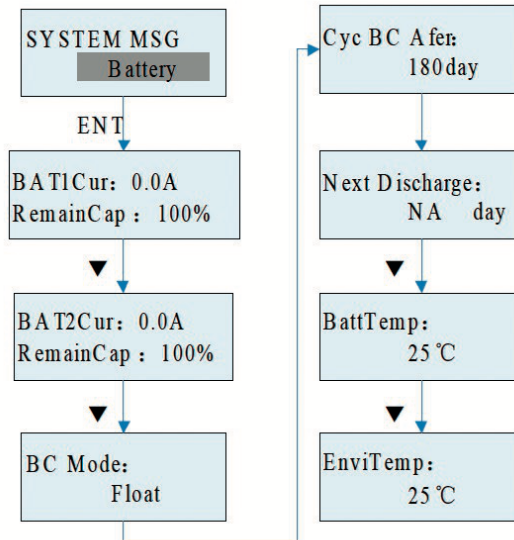

Fig4-6. Battery Message

4.4.3 Software Version

You may view the software version of the controller by pressing “ENT” enter “SW Version” menu. Flow is shown in Fig4-7.

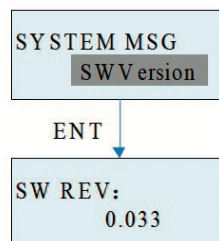

Fig4-7. Software Version

4.5 System Control

You can control the system by changing the parameters in the “System Ctl” menu. The current limit point of rectifier ,quick EQ charge, LCD background light,and on/off status of rectifiers can be controlled.The flow is shown in Fig4-8.

4.5 System Message

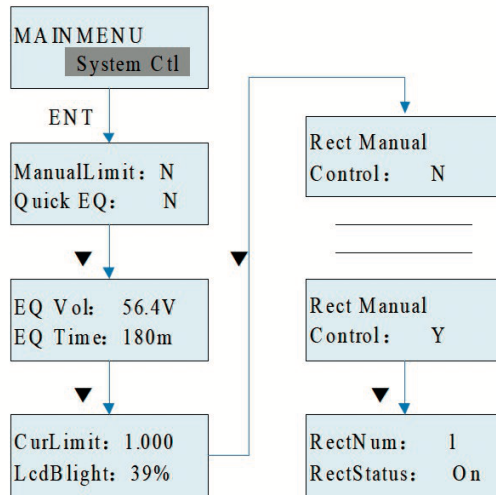

Fig4-8. System Control

You may pitch on one parameter by moving cursor to its place and pressing “ENT”, the background will turn to black. Then press “▲” or “▼” to change the selected parameter value and “ENT” to save this change. For more details about parameters of system control ,please refer to Table4-

Table 4-1 System Control Parameter

parameter	range	default	tips
Manual Limit	Y/N	N	Y: Limit output current with “CurLimit” N: Disable manual limit
Quick EQ	Y/N	N	Y: Set output voltage to EQ Voltage N: Disable Quick EQ
EQ Vol	Float voltage-DC voltage high	56.4V	Output voltage when equal charge
EQ time	voltage high	180min	Continuous equal charge time

4.4.2 Battery Message

parameter	range	default	tips
CurLimit	0.2-1.0	1.00	Rectifier output current when enable manual limit
LCDBlight	28%-50%	39%	LCD background light
Rect Manual Control	Y/N	N	Y: Enable manual control rectifier N: Disable manual control rectifier
RectNum	1-32	1	The number of rectifier to be controlled
RectStatus	On/Off	On	On: Turn on the selected rectifier Off: Turn off the selected rectifier

Only changing the value of “Rect Manual Control” to “Y”, can you manually control the rectifier on/off. After that ,you may press “▼” to display controlling screen, and choose the rectifier No. you want to change its on/off status , change the value of “RectStatus” to turn on or turn off the rectifier at last.

4.6 Settings

Most of parameters of the power system can be modified in “Settings” menu. This menu contains six submenu such as alarm settings, battery settings, DC settings, system settings, energy saving and battery test. The menus is shown in Fig4-9. In order to protect parameters from unprofessional operation, three groups password were built. Only inputting the exact password can you have the right to operate. From lowest priority to the highest is user password(1111), engineer(2222) password and manager password(3333). The higher priority, the more messages can be viewed, and the more parameters can be modified.

4.6 System Message

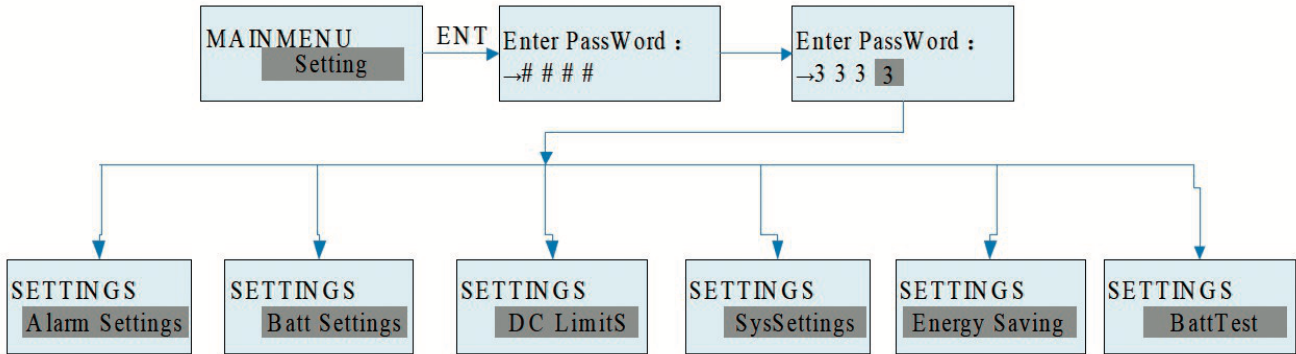

Fig4-9. Setting Menu Structure

Key “ENT” must be pressed to choose the first number of password, and press “▲” key to increase or “▼” key to decrease the number, then press “ENT” to confirm the number you have modified. You can follow these steps to modify the last numbers.

4.6.1 Alarm Settings

You may setup all alarm level, correlative relay, sound disable/enable, and digital sensor input type in “Alarm Settings” menu. Its structure is shown in Fig4-10.

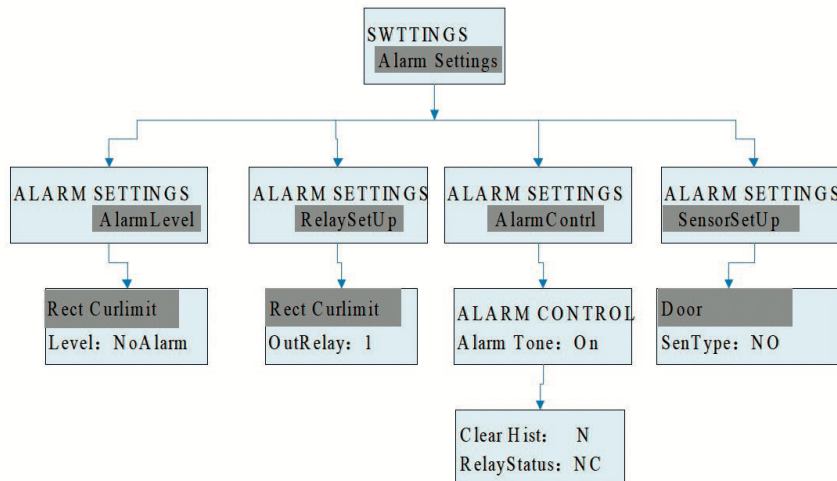

Fig4-10.Alarm Settings Menu

Total 32 alarms can be configured to independent alarm level and independent relay. default settings were shown in Table4-2.

4.6.1 Alarm Settings

Alarm Name	Level	Correlative Relay	Tips
Rect limit	NoAlarm	None	Faults inner rectifier or between rectifiers
Rect DCOVerVolt	Major	3	
Rect DCUnderVolt	Major	3	
Rect ACOVerVolt	NoAlarm	None	
Rect ACUnderVol	NoAlarm	None	
Rect Fan Fault	Minor	3	
Rect AmbOverTemp	NoAlarm	None	
Rect AmbUnderTemp	NoAlarm	None	
Rect PFCOverTemp	NoAlarm	None	
Rect DCOVerTemp	NoAlarm	None	
Rect NoRespond	NoAlarm	None	
Rect DCDCEEPROM	NoAlarm	None	
Rect Derated_AC	NoAlarm	None	
Rect DeratedTmp	NoAlarm	None	
Rect Curr Share	NoAlarm	None	
Rect Comm Fault	Major	3	Communication break off with controller
ACInput Failure	Minor	1	System input voltage high or low
AC Stop	Major	1	
Output Fault	Minor	3	System output voltage high or low
Batt Over-Curr	Minor	4	
BattTemp Fault	Minor	4	
AmbiTemp Fault	Minor	4	
Batt CB Alarm	Major	2	
Load CB Alarm	Major	2	
LLVD	NoAlarm	None	
BLVD	Major	None	
SPD	NoAlarm	None	

Smoke	NoAlarm	None	
-------	---------	------	--

4.6.1 System Message

Alarm Name	Level	Correlative Relay	Tips
Water	NoAlarm	None	
Door	NoAlarm	None	
Digital5	NoAlarm	None	
Digital6	NoAlarm	None	

Please press into “Alarm Level” menu if you want to modify a alarm level. Press “▲” or “▼” to choose the alarm to be setup, and press “ENT” to confirm you selection. Then press “▼” to move cursor to level parameter and make the parameter to be active by pressing “ENT”, press “▲” or “▼” to modify level value and “ENT” to confirm the modification. The same way can be used to modify correlative relay.

Alarm sound and relay status can be set if you press into “Alarm Control” menu.in addition, you can clean up history alarm note if necessary. Digital input type can be configured if needed.

Table4-3 is referred to your modify operation.

Table4-3 Alarm Control Or Sensor Setup

parameter	range	default	Tips
Alarm tone	Disable/Enable	Disable	Disable:No sound when alarm happens Enable:Buzzer sounds when alarm happens
Alarm relay status	NC/NO	NC	NO:Relay close when no alarm NC:Relay open when no alarm
Clean up history alarm	Y/N	N	Y:Clean up history alarm N:No effect
Sensor type	NC/NO	NO	NO:Nomal open Sensor NC:Nomal clsos Sensor
Door Smoke Water SPD			

4.6.2 Battery Settings

Some parameters of battery management could be configured in “Batt Settings” menu, such as floatcharge voltage, battery capacity, BLVD voltage, LLVD voltage, charge coefficient, and so on. Flow is shown in Fig3-11 and parameters in Table 4-4.

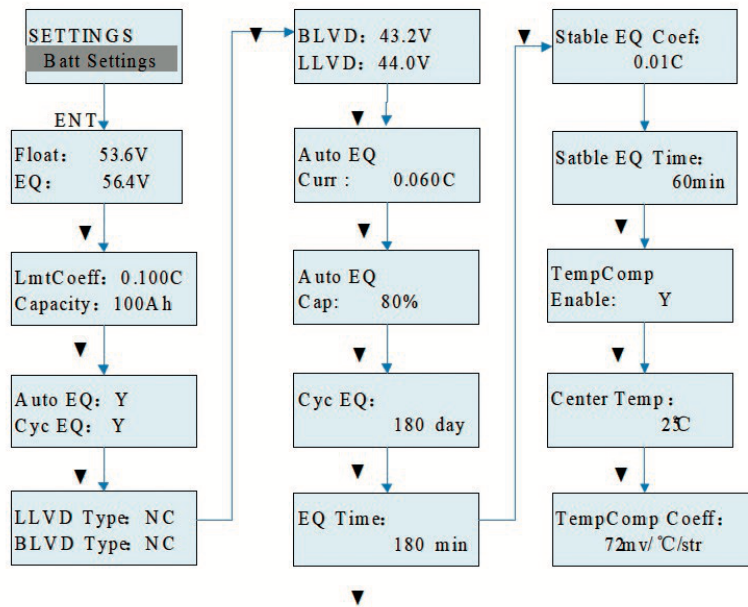

Table 4-4 Battery Management Parameters

parameters	range	default	tips
Flaot	42.0V--EQ	53.5V	Float charge mode output voltage
EQ	Float--DC High	56.4V	EQ charge mode output voltage
LimitCoeff	0.100C--1.00C	0.100C	The charge current of battery to be limited, C is battery capacity. For example, C is
Capacity	10Ah—9999Ah	100Ah	Battery capacity
Auto EQ	Y/N	Y	Enable/Disable automatic EQ charge

4.6.2 System Message

parameters	range	default	tips
Cyc EQ	Y/N	Y	Enable/Disable automatic cycle charge
LLVD Type	NO/NC	NO	Load LVD type
BLVD Type	NO/NC	NO	Battery LVD type
BLVD	40.0V--LLVD	43.2V	Cut off important load when system voltage below this value
LLVD	BLVD—DC Low	44.0V	Cut off non-important load when when system voltage below this value
Auto EQ Curr	0.040C--0.080C	0.060C	Turn to EQ charge if battery current over this value
Auto EQ Cap	10%--99%	80%	Turn to EQ charge if battery capacity lower then this value
Cyc EQ	2--360day	180day	Cycle EQ charge time
EQ Time	60min--2880min	180min	Continuous EQ charge time
Stable EQ Coeff	0.002C--0.05C	0.010C	Turn to stable EQ charge from EQ charge mode if battery current less than this value
Stable EQ Time	0--120min	60min	The time stable EQ charge mode last
TempComp Enable	Y/N	Y	Y) Enable temperature compensating N) Disable temperature compensating
Center Temp	10) --40)	25)	The center for temperature compensating
TempComp Coeff	0-500 mV/)	72mV/)	The step of voltage compensation when the battery temperature is higher or lower than ceter temperature

4.6.3 DC Limit Settings

You may change the DC limit parameters including DC output over/under voltage, battery/Environment over/under temperature ,shunt coefficient by operating the “DC limits” menu. Formore details about the parameters, please refer to Table4-5, and the flow is shown in Fig4-12.

4.6.3 Battery Settings

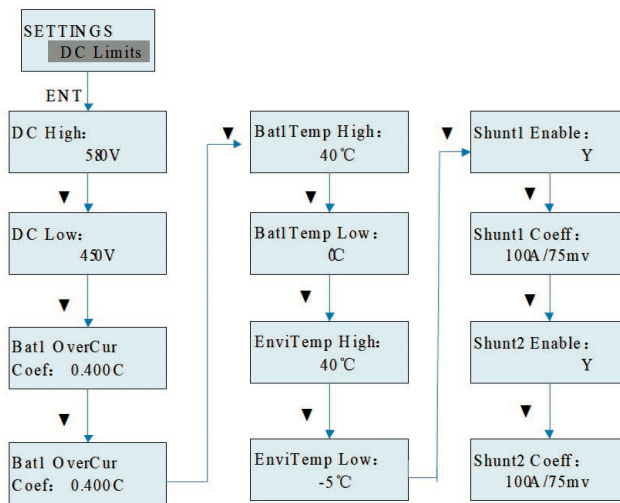

Fig4-12 DC Limits Settings

Table4-5 DC Parameter illustration

Parameter	Range	Default	illustration
DC High	DC Low Point-60V	58V	DC output over voltage point
DC Low	LLVD Point-DC High Point	45V	DC output under voltage point
Bat1 OverCur	0.1C-0.5C	0.4C	Charge of battery over current point
Bat2 OverCur			
BatTemp High	10°C-75°C	40°C	Battery over temperature point
BatTemp Low	-10°C-40°C	0°C	Battery under temperature point
EnviTemp High	10°C-75°C	40°C	Environment over temperature point
EnviTemp Low	-10°C-40°C	-5°C	Environment under temperature point
Shunt1 Enable	Y/N	Y	Y:Enable Shunt1

4.6.3 System Message

			N:Disable Shunt1
Shunt1 Coeff	0-2000A/1-500mV	100A/75mv	must match the actual shunt is used for battery1
Shunt2 Enable	Y/N	Y	Y:Enable Shunt2 N:Disable Shunt2
Shunt2 Coeff	0-2000A/1-500mV	100A/75mv	must match the actual shunt is used for battery2

4.6.4 System Parameter

You may change system parameters including language, date, time, system code, and update software by operating the "SysSettings" menu. If you want to use SNMP to communicate with the central monitor unit, you may change the IP address, Mask address, and Gateway. The operation flow is shown in Fig4-13.

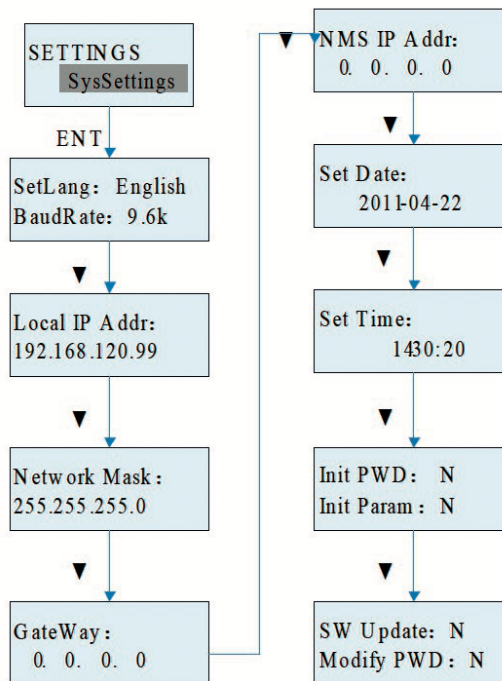

Fig4-13 System Parameter Settings

4.6.4 Battery Settings

The value of baudrate means the speed of RS232 or RS485 bus used to communicate with host. If you want to reset all the parameter of the controller, you may change the value of "Init Param" to "Y". You may update the software through these menus if necessary.

4.6.5 Energy Saving

In order to make rectifiers work on the most efficient point, the controller will control the rectifiers work or sleep to save energy. You may change the parameters by operating the "Energy Saving" menu. The function is disable acquiescently. For more details about the parameters, please refer to Table4-6, and the flow is shown in Fig4-14.

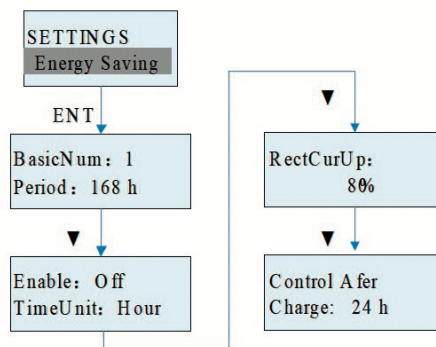

Fig4-14 Energy Saving Settings

Table4-6 Energy Parameters

Parameter	Range	Default	illustration
BasicNum	1—2	1	The least quantity of working rectifiers in energy saving mode
Period	1h-720h	168h	The period of the rectifier from sleeping to working
Enable	Close/Open	Close	Close: Enable energy saving Open: Disable energy saving
Time Unit	min/hour	hour	Hour: The time parameters about energy

			saving runs in hours Min: The time parameters about energy saving runs in minutes
RectCurUp	80%-95%	80.00%	If the load of each rectifier is over this value, the controller will turn on the sleeping rectifiers one by one ,until the load is under it.
Control Ater Charge	1-240	24h	The controller start to work in Energy Saving mode after working the time be set.

The energy saving function of CAS-03D controller is turn off acquiescently,you may turn on it by changing the “Enable” value to “On” if necessary,the controller supplies two energy saving modes,one is for common rectifiers,the other is for mixed rectifiers.The controller can identify two modes automatically.

Energy Saving mode1(all the rectifiers are common or high efficiency):

A. Turn off rectifiers: If the load of each rectifier is under 40% of its rated load,the controller will turn off the rectifiers one by one,until the load is over 40%.Atually,the least quantity of working rectifiers will match to the “BasicNum”.

B. Turn on rectifiers: If the load of each rectifier is over the value(default:80%) set in “RectCurUp”, the controller will turn on the sleeping rectifiers one by one ,until the load is under the value.

C.Sleep by turns : If there are some rectifiers sleeping,the controller will turn on one,when its sleeping time meets the time set in “period”,and then turn off the working longest rectifier.

Energy Saving mode2(there are common rectifiers and high efficiency rectifiers in the system):

Let’s suppose 1# and 2# to be high efficiency rectifier,3# and 4# to be common rectifier.

A. Turn off rectifiers: If the load of each rectifier is under 40% of its rated load,the controller will turn off the rectifiers one by one,until the load is over 40%. The controller will turn off the common rectifiers first,the order is 4#>3#>2#>1#. Atually,the least quantity of working rectifiers will match to the

4.6.4 Battery Settings

“BasicNum”.

B. Turn on rectifiers: If the load of each rectifier is over the value(default:80%) set in “RectCurUp”, the controller will turn on the sleeping rectifiers one by one ,until the load is under the value.

The controller will turn on the high efficiency rectifiers first,the order is 1#>2#>3#>4#.

C. Sleep by turns) If there are some rectifiers sleeping,the controller will turn on one,when its sleeping time meets the time set in “period”,and then turn off the working longest rectifier.The controller will turn on the high efficiency rectifier first(if there is),and turn off the common rectifier(if there is).

4.6.6 Battery Test

The battery test function of CAS-03D controller is turn off acquiescently.

You may turn on the function by operating the “Batt Test” menu,and change other parameters about battery test. For more details about the parameters, please refer to Table4-7,and the flow is shown in Fig4-15.

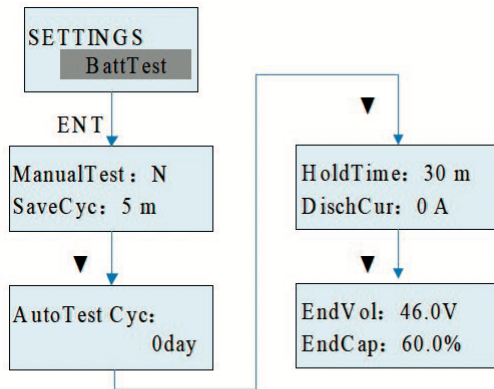

Fig4-15 Battery Test Settings

Table4-7 Battery Test Parameter

Parameter	Range	Default	illustration
Manual Test	Y/N	N	Y: Enable manual battery test

4.6.6 System Message

			N: Disable manual battery test
Save Cyc	2—10min	5min	The period that save the data of battey
Auto Test Cyc	0—365day	0	0: Disable automatic test 1-365: The period of automatic test
Hold Time	5—1200min	30min	Time that the test will hold
DischCur	0—600A	0A	0:Discharge with the actual load 1-600: The discharge current we want to reach
End Vol	42.0V-48V	46.0V	When the battery voltage is lower than this value, the test will end
End Cap	1%-99%	60.00%	When the battery capacity is lower than this value, the test will end

4.6.7 AC Parameter

You may change the AC input over/under voltage point by operating the “AC Settings” menu. For more details, please refer to Table4-8 and Fig4-16.

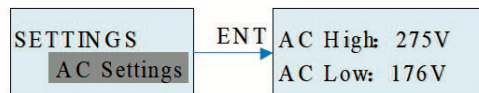

Fig4-16 AC Settings

Table4-8 AC Parameter

Parameter	Range	Default	illustration
AC High	250V—300V	275V	AC input over voltage point
AC Low	100V—220V	176V	AC input under voltage point

4.6.8 Alarm summarize

The CAS-03D controller supplies 32 alarm types. It shows sound, light, and trigger correlative relay when an error happens. You can close or open the alarm, and choose the correlative relay by setting the alarm parameters. If you want to know more about the alarm, please refer to the section 4.6.1.

5 Maintenance

Please refer to Table5-1.

Table5-1 Faults Analysis

Faults	Possible causes	Solution
Battery current Inaccurate	The shunt coefficient is set wrong	Check the shunt coefficient in controller ,and insure it match the character wrote on the shunt
Controller can not control the LVD contactor open or close	The LLVD Type or BLVD Type is set wrong	Check the LLVD Type and BLVD Type,and insure it match the contactor type
Communication break off btween controller and rectifiers	The connection is loose or CAN bus is conected wrong	Fasten the connection of the CAN bus ,and check polarity of bus
The LCD display improperly	LCD has an error	Please contact the manufacturer
The Controller does not work	The fuse of the controller is broken	Please contact the manufacturer

6 Service information

6.1 Warranty

Limitation of Warranty

The foregoing warranty shall not apply to defects resulting from unauthorized modification or misuse, or operations beyond the described in this manual. No other warranty is expressed or implied.

Whilst every care has been taken in compiling the information in this publication, Powtech cannot accept legal liability for any inaccuracies contained herein. Powtech has an intensive program of design and development which may well alter product specification, and reserve the right to alter specification without notice and whenever necessary to ensure optimum performance from its product range.

In particular, Powtech is not responsible for any lost profits or revenue, loss of use software, loss of data, cost of substitute software, claims by third parties, or for other similar costs. In no case shall Powtech's liability exceed the amount of the license fee.