

# HighLighter® LED Mini-Lightbars



---

## *Installation, Operation, and Maintenance Instructions*



---

# Contents

<b>Safety Message to Installers of Warning Light Equipment .....</b>	<b>5</b>
<b>Safety Messages to Operators of Warning Light Equipment.....</b>	<b>8</b>
<b>Unpacking the Lightbar .....</b>	<b>9</b>
<b>Overview of the HighLighter LED Mini-Lightbars .....</b>	<b>9</b>
<b>Preparing for the Lightbar Installation .....</b>	<b>11</b>
Determining the Mounting Location and Wire Routing .....	11
<b>Magnetic or Magnetic/Suction Mounting .....</b>	<b>13</b>
<b>Permanently Mounting the HighLighter .....</b>	<b>14</b>
Preparing the Mounting Surface.....	14
<b>Wiring the HighLighter LED.....</b>	<b>15</b>
Wiring the Synchronize Feature (If Configured) .....	16
Enabling the Synchronize Feature (If Configured) .....	16
Wiring the High-Side Outputs (If Configured).....	16
Wiring the Dim Feature.....	17
Completing the Wiring .....	17
Completing the Permanent Mounting.....	18
<b>Selecting a Flash Pattern.....</b>	<b>18</b>
Selecting a Flash Pattern Using a Magnet .....	19
Selecting a Flash Pattern Using the Internal Programming Pad .....	19
<b>Cleaning the Domes .....</b>	<b>21</b>
<b>Ordering Replacement Parts .....</b>	<b>21</b>
<b>Getting Technical Support and Service.....</b>	<b>21</b>
<b>Returning a Product to Federal Signal.....</b>	<b>22</b>

**Figures**

**Figure 1** Upper assembly removed from lightbar base..... 15  
**Figure 2** Mounting holes for Patterns A and B ..... 18  
**Figure 3** Hole for Hall-effect sensor on PCB..... 19

**Tables**

**Table 1** Mounting hardware..... 9  
**Table 2** Specifications for HighLighter LED Standard ..... 10  
**Table 3** Specifications for HighLighter LED Plus..... 10  
**Table 4** Specifications for HighLighter LED Pro ..... 11  
**Table 5** HighLighter LED Flash Patterns..... 20

## Safety Message to Installers of Warning Light Equipment

### **⚠ WARNING**

People's lives depend on your proper installation and servicing of Federal Signal products. It is important to read and follow all instructions shipped with this product and the original product. Listed below are some other important safety instructions and precautions you should follow:

#### **Before Installation or Service**

##### *Qualifications*

- To properly install or service this equipment, you must have a good understanding of automotive mechanical and electrical procedures and systems, along with proficiency in the installation and service of safety warning equipment. Always refer to the vehicle's service manuals when performing equipment installations on a vehicle.

##### *Light Hazards*

- In order to be an effective warning device, this product produces bright light that can be hazardous to your eyesight when viewed at a close range. Do not stare directly into this lighting product at a close range or permanent damage to your eyesight may occur.
- Do not install the light system in an area that would block, impair or blind the driver's vision. Ensure that the light system is mounted in a position that is outside of the driver's field of vision, so the driver can maintain safe vehicle operation.
- Federal Signal power supplies and light heads are designed to work together as a system. Combining light heads and a power supply from different manufacturers may reduce the warning effectiveness of the lighting system and may damage the components. You should verify or test your combination to make sure the system works together and meets federal, state and local standards or guidelines.

##### *Electrical Hazards*

- A light system is a high current system. In order for the system to function properly, a separate negative (-) connection and positive (+) connection must be made. All negative connections should be connected to the negative battery terminal and a suitable fuse should be installed on the positive battery terminal connection as close to the battery as possible. Ensure that all wires and fuses are rated correctly to handle the device and system amperage requirements.
- Never attempt to install aftermarket equipment that connects to the vehicle wiring, without reviewing a vehicle wiring diagram available from the vehicle manufacturer. Ensure that your installation will not effect vehicle operation or mandated safety functions or circuits. Always check the vehicle for proper operation after installation.

- Do not mount a radio antenna within 18 inches of the lighting system. Placing the antenna too close to the lighting system could cause the lighting system to malfunction or be damaged by strong radio fields. Mounting the antenna too close to the lighting system may also cause the radio noise emitted from the lighting system to interfere with the reception of the radio transmitter and reduce radio reception.
- Do not attempt to wash this or any other electrical device while it is connected to its power source. Exposure to liquid while the product is connected to the power source may result in an electrical shock and personal injury and may short circuit and damage the product.

**During Installation and Service**

- DO NOT get metal shavings inside the product. Metal shavings in the product can cause the system to fail. If drilling must be done near the unit, place an ESD approved cover over the unit. Inspect the unit after mounting to be sure there are no shavings present in or near the unit.
- To avoid a battery explosion, always disconnect the negative battery cable first and reconnect it last. Avoid causing a spark when connecting near or to the battery. The gases produced by a battery can cause a battery explosion that could result in vehicle damage and serious injury.
- DO NOT connect this system to the vehicle battery until ALL other electrical connections are made, mounting of all components is complete, and you have verified that no shorts exist. If the wiring is shorted to the vehicle body or frame, high current conductors can cause hazardous sparks resulting in electrical fires or flying molten metal.
- DO NOT install equipment or route wiring (or the plug in cord) in the deployment path of an airbag.
- If a vehicle seat is temporarily removed, verify with the vehicle manufacturer if the seat needs to be recalibrated for proper airbag deployment.
- Before mounting any components, check the manual to be sure that the component you are installing is suitable for use in that area of the vehicle. Many components are not suitable for use in the engine compartment or other extreme environmental exposure areas.
- When drilling into a vehicle structure, be sure that both sides of the surface are clear of anything that could be damaged. Remove all burrs from drilled holes. To prevent electrical shorts, grommet all drilled holes through which wiring passes. Also, ensure that the mounting screws do not cause electrical or mechanical damage to the vehicle.
- Refer to the instruction sheet packed with the lighting system for proper electrical connections, additional precautions and information.

- Because vehicle roof construction and driving conditions vary, do not drive a vehicle with a magnetically mounted warning light installed. The light could fly off the vehicle causing injury or damage. Repair of damage incurred because of ignoring this warning shall be the sole responsibility of the user.
- To avoid denting the roof of the vehicle, place the lightbar mounting feet as close to outer edge of the roof as possible.
- Locate the light system controls so the VEHICLE and CONTROLS can be operated safely under all driving conditions.

**After Installation or Service**

- After installation, test the light system to ensure that it is operating properly.
- If a seat is temporarily removed, verify with the vehicle manufacturer if the seat needs to be recalibrated for proper airbag deployment.
- Test all vehicle functions, including horn operation, vehicle safety functions and vehicle light systems, to ensure proper operation. Ensure that the installation has not affected the vehicle operation or changed any vehicle safety function or circuit.
- Scratched or dull reflectors, mirrors or lenses will reduce the effectiveness of the lighting system. Avoid heavy pressure and use of caustic or petroleum based products when cleaning the lighting system. Replace any optical components that may have been scratched or crazed during system installation.
- Do not attempt to activate or de-activate the light system control while driving in a hazardous situation.
- You should frequently inspect the light system to ensure that it is operating properly and that it is securely attached to the vehicle.
- After installation and testing are complete, provide a copy of these instructions to instructional staff and all operating personnel.
- File these instructions in a safe place and refer to them when maintaining and/or re-installing the product.

Failure to follow all safety precautions and instructions may result in property damage, serious injury, or death.

**RETAIN AND REFER TO THESE MESSAGES**

## **Safety Messages to Operators of Warning Light Equipment**

### **⚠ WARNING**

- Peoples' lives depend on your safe use of our products. Listed below are some important safety instructions and precautions you should follow:
- Although your warning system is operating properly, it may not be completely effective. People may not see or heed your warning signal. You must recognize this fact and continue driving cautiously.
- Also, situations may occur which obstruct your warning signal when natural and man-made objects are between your vehicle and others, such as raising your hood or trunk lid. If these situations occur, be especially careful.
- All effective sirens and horns produce loud sounds which may cause, in certain situations permanent hearing loss. You and your passengers should consider taking appropriate safety precautions such as wearing hearing protection.
- In order to be an effective warning device, this product produces bright light that can be hazardous to your eyesight when viewed at a close range. Do not stare directly into this lighting product at a close range or permanent damage to your eyesight may occur.
- It is important that you fully understand how to safely operate this warning system before use.
- You should only operate your vehicle and its light/sound system in accordance with your department's Standard Operating Procedure.
- If a selected function does not perform properly or if any of the lamps remain illuminated when the control is off, disconnect the power connector from the control unit and contact the nearest service center.
- At the start of your shift, you should ensure that the entire warning light system and the siren system is securely attached and operating properly.
- Suction cup mounting is for temporary applications only. The unit should be removed from the window and stored securely when not in use. Temperature changes and sunlight can cause suction cups to lose holding power. Periodically check the unit to be sure the suction cups have a firm grip on the mounting surface. An improperly secured light could fall off of the vehicle causing injury and damage.
- The holding power of magnetic mounting systems is dependent upon surface finish, surface flatness, and thickness of the steel mounting surface. Therefore, to promote proper magnetic mounting:
  - ✓ Mounting surface and magnets must be kept clean, dry, and free of foreign particles that prevent good surface contact.



- ✓ Ensure that mounting surface is flat.
- ✓ A magnet mounting system should not be used on vehicles with vinyl tops.
- ✓ To prevent sliding of the light assembly on the mounting surface, quick acceleration and hard stops should be avoided.

Failure to follow these precautions may result in property damage, serious injury, or death.

**RETAIN AND REFER TO THESE MESSAGES**

## **Unpacking the Lightbar**

After unpacking the product, inspect it for damage that may have occurred in transit. If the product has been damaged, do not attempt to install or operate it. File a claim immediately with the carrier, stating the extent of damage. Carefully check all envelopes, shipping labels, and tags before removing or destroying them. Ensure that the parts in Table 1 are contained in the packing carton. If any part is missing, call the Federal Signal Service Department at 1-800-433-9132.

**Table 1** Mounting hardware

<b>Qty.</b>	<b>Description</b>	<b>Part Number</b>
4	Screw, Thread Forming, 1/4"	7011A158-12
1	Grommet	8108A002
1	Foam Mounting Pad	8560102

## **Overview of the HighLighter LED Mini-Lightbars**

The HighLighter LED Mini-Lightbar is a high-performance warning light with a small outline and low current draw. It is designed to control or be controlled as part of a greater lighting system. Its two alternating high-side flasher outputs, each with a 5 A capacity, enable a perimeter lighting system to be sequenced with the flash pattern of the HighLighter. A synchronize feature also enables two or more HighLighter LED assemblies to flash in unison. An external low-side flasher, such as Federal Signal models 650202, 650203 or 650206, can also control the HighLighter LED using the SYNC IN/DIM wire.

The HighLighter LED suction-cup and magnet mount models include a cigarette lighter plug and built-in ON-OFF switch that makes them simple to install and just as simple to operate. Incorporated into the top of the LED dome in all models is Federal Signal's innovative MagnetSelect™ feature that enables users to quickly and easily select from more than user-selected flash patterns using a simple magnet.

**Table 2** Specifications for HighLighter LED Standard

Specifications			
Amp Draw	Max: 4 A (total amp draw depends on flash pattern used)		
Flash Rate	Various		
LED Count	26		
LED Color Options	Amber		
Lens Color Options	Amber and Clear		
Physical Specifications			
	Permanent mount	Magnetic mount	Suction-cup mount
Length	15.3 in. (38.8 cm)		
Width	8.4 in (21.3 cm)		
Height	2.7 in (6.6 cm)	3.0 in (7.6 cm)	3.0 in (7.6 cm)
Ship Weight			
	3.4 lb (1.5 kg)	4.5 lbs (2.0 kg)	6.0 lbs (2.7 kg)

**Table 3** Specifications for HighLighter LED Plus

Specifications			
Amp Draw	Max: 4.8 A Note: Total amp draw depends on flash pattern used.		
Flash Rate	Various		
LED Count	36		
LED Color Options	Amber, Blue, Clear, Green and Red		
Lens Color Options	Amber, Blue, Clear, Green and Red		
Physical Specifications			
	Permanent mount	Magnetic mount	Suction-cup mount
Length	15.3 in. (38.8 cm)		
Width	8.4 in (21.3 cm)		
Height	2.7 in (6.6 cm)	3.0 in (7.6 cm)	3.0 in (7.6 cm)
Ship Weight			
	3.4 lb (1.5 kg)	4.5 lbs (2.0 kg)	6.0 lb (2.7 kg)

**Table 4** Specifications for HighLighter LED Pro

Specifications			
Amp Draw	Max: 5.7A Note: Total amp draw depends on flash pattern used.		
Flash Rate	Various		
LED Count	42		
LED Color Options	Clear		
Lens Color Options	Amber, Blue, Clear, Green and Red		
Physical Specifications			
	Permanent mount	Magnetic mount	Suction-cup mount
Length	15.3 in. (38.8 cm)		
Width	8.4 in (21.3 cm)		
Height	2.7 in (6.6 cm)	3.0 in (7.6 cm)	3.0 in (7.6 cm)
Ship Weight			
	3.4 lb (1.5 kg)	4.5 lbs (2.0 kg)	6.0 lbs (2.7 kg)

## Preparing for the Lightbar Installation

Taking the preparatory steps in this section before mounting and wiring the lightbar to a vehicle will help ensure that your installation is fast, easy, and error free.

### ***Determining the Mounting Location and Wire Routing***

To prepare for the installation:

- Ensure that the battery voltage is the same as the voltage rating of the lightbar.
- Verify that the lightbar and mounting hardware fit the vehicle.
- Determine where to mount the lightbar on the vehicle.

#### **⚠ WARNING**

***LOCATING OPERATOR CONTROLS: The controls for the light system must be located so that the VEHICLE and CONTROLS can be operated safely under all driving conditions.***

#### **⚠ WARNING**

***AIRBAG DEPLOYMENT: Do not install equipment or route wiring in the deployment path of an airbag. Failure to observe this warning will reduce the effectiveness of the airbag or potentially dislodge the equipment, causing serious injury or death.***

- Decide where to route wiring around airbag areas.

- Decide where to route the power and ground wires from the lightbar.

**⚠ WARNING**

**SEAT REMOVAL PRECAUTION:** *If a vehicle seat is temporarily removed, verify with the vehicle manufacturer if the seat needs to be recalibrated for proper airbag deployment. Failure to follow this warning cause serious injury or death.*

- To make wiring easier, remove the seats, spare tire, and pull down the headliner where needed.
- Separate all electronic equipment wiring from two-way radio equipment wiring.

**NOTICE**

**INSTALLATION PRECAUTIONS:** *The warning system and/or two-way radio system may operate improperly if a two-way radio antenna installed on or within 18 inches of the lightbar. Before permanently installing the lightbar or a two-way radio antenna, test the warning system and two-way radio system. DO NOT install a two-way radio antenna on the lightbar. Some installations may require the relocation of the two-way radio antenna to a trunk or fender location. DO NOT drill holes in the lightbar or install auxiliary devices on the lightbar or the warning system may fail.*

- To avoid interference, keep two-way radio antennas a minimum of 18 in (45.7 cm) away from warning equipment.
- Whenever possible, run full wire lengths. DO NOT splice the wires.
- Do not coil excess wire. Leave a drain loop for servicing the lightbar.
- After drilling holes for wires, deburr them, smooth sharp edges, and insert grommets to protect the wires from chafing.
- When you frame-ground the equipment, use the manufacturer-supplied ground locations in the vehicle.

**IMPORTANT:** After the installation, frequently inspect the lightbar and mounting feet to ensure that all fasteners and brackets are tight.

## Magnetic or Magnetic/Suction Mounting

**⚠ WARNING**

***DO NOT DRIVE WITH MAGNETICALLY-MOUNTED WARNING LIGHT INSTALLED: Because vehicle roof construction and driving conditions vary, do not drive a vehicle with a magnetically mounted warning light installed. The light could fly off the vehicle causing injury or damage. Repair of damage incurred because of ignoring this warning shall be the sole responsibility of the user.***

**⚠ WARNING**

***PROPER MAGNETIC MOUNTING: The holding power of magnetic mounting systems is dependent upon surface finish, surface flatness, and thickness of the steel mounting surface. Therefore, to promote proper magnetic mounting:***

- ✓ ***The mounting surface and magnets must be kept clean, dry, and free of foreign particles that prevent good surface contact.***
  - ✓ ***Ensure that the mounting surface is flat.***
  - ✓ ***A magnet mounting system should not be used on vehicles with vinyl tops.***
  - ✓ ***To prevent sliding of the lightbar on the mounting surface, quick acceleration and hard stops should be avoided.***
1. Place the lightbar assembly on the vehicle roof at a location that provides maximum signaling effectiveness for your application.
  2. For models with suction cups, release trapped air by applying downward pressure to the top of the dome while pulling up on the release wires.
  3. To operate the magnet-mounted lightbar assembly, insert the plug at the end of the cable assembly in the cigarette lighter socket. Turn the plug on and off using the power switch on the plug. To show that the power is on, a pilot light turns on.
  4. To remove models with suction cups, pull up on the release wires while picking up the lightbar.

## Permanently Mounting the HighLighter

### NOTICE

**FLAT MOUNT BRACKETS:** *Curved mounting locations may distort the base of the lightbar if the mounting screws are over-tightened. To prevent the base from being distorted, use the Flat Mount Brackets. They are available separately as Federal Signal part number 454218.*

The lightbar is completely wired at the factory and does not require any additional internal wiring. User-supplied 18 AWG or larger wire may be added if required. Optional 15-foot cable kits are available from your dealer or Federal Signal.

Before beginning any installation, plan the wiring path and mounting method. Depending on the number of lightbars installed and the distance between connection points, you may need to install heavier gauge wire.

### NOTICE

**FLAT MOUNT BRACKETS:** *Curved mounting locations may distort the base of the lightbar if the mounting screws are over-tightened. To prevent the base from being distorted, use the Flat Mount Brackets. They are available separately as Federal Signal part number 454218.*

### Preparing the Mounting Surface

Select a relatively flat and level position on the mounting surface. Figure 2 on page 18 shows two patterns, (A and B) of mounting holes. For greater swiraility, use the Pattern B holes shown in the figure. Pattern B is an alternate set of holes that are closer to the corners.

**NOTE:** Install the lightbar with the notch in its base (Figure 2) facing the rear of the vehicle.

To prepare the mounting surface:

1. Select the mounting-hole pattern most appropriate for your installation and scribe four drill position marks on the mounting surface. The wire-routing hole can be located beneath the wire exit. If the wires will be routed down, scribe a drill-position mark for the hole on the mounting surface at the selected location. A channel is provided to run the wires to the back of the lightbar, if needed.
2. Drill four 9/32-inch mounting holes at the scribed drill-position marks. If required, drill one 1/2-inch hole at the scribed mark for routing the wires. Install the grommet in the wire-routing hole.

**NOTE:** If the wire needs to be routed through the mounting pad, carefully cut an opening in the pad and route the lightbar wires through it.

3. To complete the installation, see “Wiring the HighLighter LED” on the next page.

## Wiring the HighLighter LED

The permanent-mount HighLighter LED has 18 inches of pre-installed lead wire. The lead wire may have to be spliced into the harness using installer-supplied terminals. To avoid leaving a splice exposed, there is the option of running an intact wire into the lightbar.

### NOTICE

**HIGH CURRENT DEVICE: A light system is a high current system. In order for the system to function properly, a separate negative (-) connection and positive (+) connection must be made. All negative connections should be connected to the negative battery terminal and a 10 A fuse should be installed on the positive battery terminal connection as close to the battery as possible. Ensure that all wires and fuses are rated correctly to handle the system amperage requirements**

1. Connect the red wire to one terminal of a user-supplied switch with a current handling capacity of at least 10 amperes.
2. Connect the black wire to the vehicle chassis as close as practical to the light. Extend wiring with 18 AWG wire minimum.

**Figure 1** Upper assembly removed from lightbar base

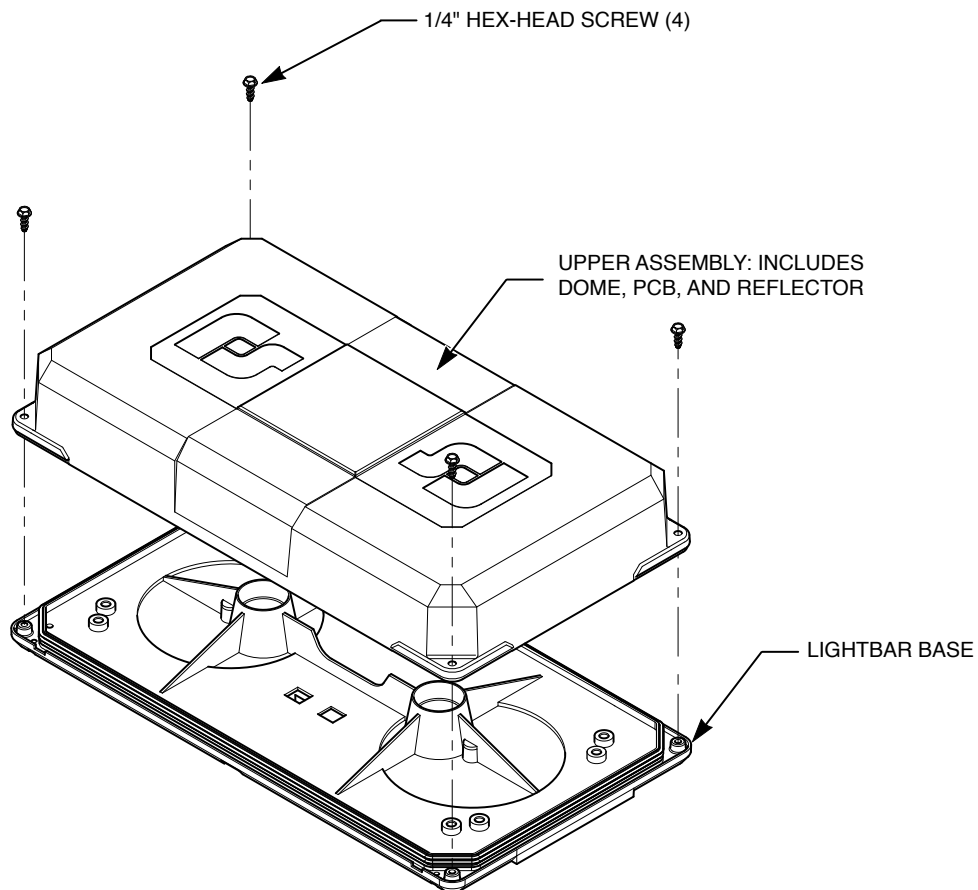

### ***Wiring the Synchronize Feature (If Configured)***

The synchronize feature of the HighLighter LED enables two or more light assemblies to flash together or alternately.

The wires SYNC OUT 1 and SYNC OUT 2 flash alternately in most patterns and together in others. Some patterns light different sets of LEDs in the controller HighLighter. Note that HighLighter LEDs driven by their SYNC IN/DIM wires light up completely. The best appearance for a synchronized system is a pattern that flashes the entire lightbar. See “Selecting a Flash Pattern” on page 18.

### ***Enabling the Synchronize Feature (If Configured)***

#### **NOTICE**

***SET ONLY ONE CONTROLLER: When putting together systems of HighLighter LED lightbar, ensure there is only one controller lightbar. If more than one lightbar in a system is a controller, the follower lightbars will malfunction.***

To enable the synchronize feature:

1. Select the HighLighter LED lightbar configured as the controller.
2. Connect an 18 AWG wire or wires to the yellow wire SYNC OUT 1 or to the orange wire SYNC OUT 2. Route the wire to any other HighLighter LED lightbar that is to be flashed synchronously.
3. Connect the SYNC OUT wire(s) from the controller HighLighter LED to the white wire SYNC IN/DIM on any HighLighter LED to be controlled. To create sophisticated flash patterns, both sync channels can be connected to separate banks of HighLighter LEDs.

**NOTE:** For the SYNC IN/DIM wire to be active, set the controlled HighLighter LEDs to Pattern 21.

**NOTE:** The SYNC IN/DIM wire may also be connected to a low-side flasher such as Federal Signal models 650202, 650203, or 650206. Connecting the SYNC IN/DIM terminal to ground turns on the entire lightbar. Several HighLighter LEDs can be connected to the same flasher channel. The power and ground connections at the HighLighter LED are still required.

### ***Wiring the High-Side Outputs (If Configured)***

Two high-side flasher outputs are also provided. The outputs can be connected to external loads rated up to 5 A each that are to flash in sequence with the HighLighter LED. Connect the brown wire of HSD1 or the brown/white wire of HSD2 to the positive terminal on each load. HSD1 provides positive voltage when SYNC OUT 1 is active. HSD2 provides positive voltage when SYNC OUT 2 is active. These outputs must be protected by installer-provided 5 A in-line fuse. When selecting the size of the wiring for installation when these high-side outputs are used, add their total current to that of the HighLighter LED.



### **Wiring the Dim Feature**

A dim feature is available on the Plus and Pro models. The feature dims the lights approximately 40 percent to prevent blinding approaching drivers. Dim Mode is activated by applying ground to the white SYNC IN/DIM wire when displaying any of the 19 selectable flash patterns. Dim Mode is not available for the sync feature.

### **Completing the Wiring**

To complete the wiring:

1. Insert the grommet into the wire-routing hole and route the wires through the hole.
2. To prevent water leakage if the wires enter into a weather-tight compartment, apply silicone sealing compound around the wires at the entry point and around the grommet. Otherwise, route the wires through the wire channel in the mounting base to the back of the lightbar.
3. Install a user-supplied controller or switch at a location that enables the driver to operate all controls safely under all driving conditions. The current capacity of the controller or switch should be at least 10 A. The positive 12/24 Vdc connection must be made to the fuse block if it is only to be operational when the vehicle is keyed on. Protect this connection with a 10 A fuse.

#### **NOTICE**

***MAKE A GOOD GROUND CONNECTION: The lightbar will not function properly without a good ground connection. Ensure that the black wire is attached to good vehicle ground.***

5. Route the wires or the optional cable kit from the control head or switch to the lightbar wires.

#### **NOTICE**

***DRESS WIRES TO PREVENT SHORT CIRCUIT: To prevent a short circuit or broken wire, dress the wires to avoid pinching between the mounting plate and mounting surface. Do not allow the mounting screws to pierce the wires.***

6. If the PROG pad is to be used for selecting the flash pattern, test the lightbar for proper operation and select the pattern as described in “Selecting a Flash Pattern” on page 18. For a description of the flash patterns, see Table 5 on page 20.
7. Within the dome are one exit and an optional knockout for wires (Figure 1 on page 15). Each wire exit can accommodate three 16 to 18 AWG wires. Guide the wires through the holes and secure the upper assembly with the four hex-head screws.

## Completing the Permanent Mounting

To complete the installation:

1. Carefully position the lightbar over the mounting holes with the mounting pad in place (if it is to be used) between the lightbar and the mounting surface.
2. Ensure that the wiring is routed neatly. Secure the lightbar to the mounting surface using the 1/4-inch thread-forming screws.

**NOTE:** The mounting screws are 5/8-inch long and provide 1/4-inch of thread engagement when you install the mounting pad on a 1/8-inch thick mounting surface. If the mounting surface is thicker, longer screws are needed or the optional pad may be omitted provided that there is a minimum of 1/4-inch of full thread engagement into the mounting base.

**Figure 2** Mounting holes for Patterns A and B

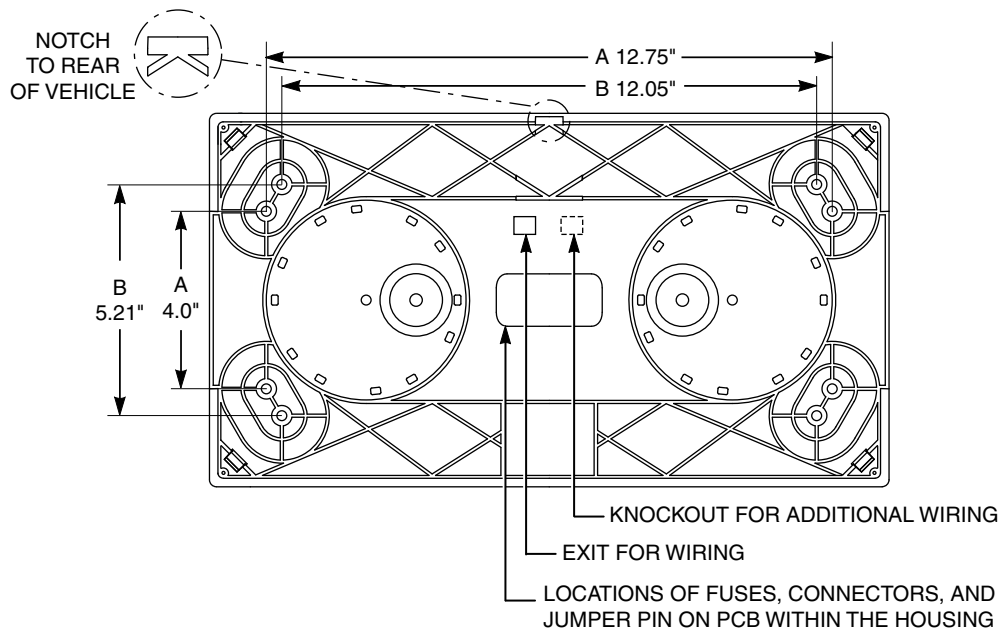

## Selecting a Flash Pattern

### **⚠ WARNING**

**LIGHT HAZARDS**—*In order to be an effective warning device, this product produces bright light that can be hazardous to your eyesight when viewed at a close range. Do not stare directly into this lighting product at a close range or permanent damage to your eyesight may occur.*

For a list of the flash patterns see Table 5 on page 20. You can change the configured flash pattern in one of two ways:

- By displaying a pattern by momentarily jumpering the programming pad inside the lightbar. The pad is accessible by removing the dome.
- By displaying a pattern by holding a strong magnet over the Hall-effect switch accessible on the upper left corner of the dome.

### **Selecting a Flash Pattern Using a Magnet**

**NOTE:** A sufficiently strong magnet is needed to change patterns. A typical retrieval tool should have enough strength. A refrigerator magnet will most likely not have the required strength. A MagnetSelect™ keychain is included with the HighLighter Plus and HighLighter Pro when the configured option is selected. It is not available on the Standard HighLighter.

To select a pattern using a magnet:

1. Remove power from the lightbar.
2. See Figure 3. Locate the programming sensor zone. The zone is over the Hall effect switch on the internal PCB.

**Figure 3** Hole for Hall-effect sensor on PCB

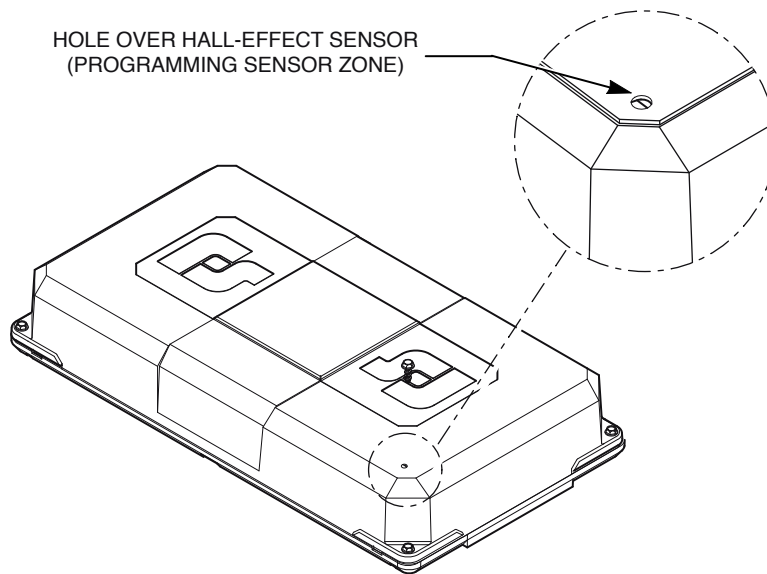

2. Hold a small, strong magnet within 1/8 inch above the hole so that the pattern moves to the next pattern in the sequence. Allow the light to flash for at least one entire flash sequence before removing the magnet. The lightbar stops flashing to indicate the pattern has changed and resumes flashing when the magnet is removed.

**NOTE:** The lightbar will not change to another pattern until you remove the magnet and reapply it after an entire pattern sequence.

3. When the pattern you want flashes, set it in memory by allowing it to operate for 10 seconds.

### **Selecting a Flash Pattern Using the Internal Programming Pad**

To select a flash pattern using the internal programming pad:

1. To access the programming pad (marked PROG) on the lightbar PCB, disassemble the lightbar

## HighLighter® LED Mini-Lightbars

2. While power is applied to the power (PLUS +) wire and ground (MINUS –) wire, use a wire to apply ground to the pad.
3. When you reach the pattern you want, set it in memory by allowing the HighLighter to display the pattern for 10 seconds.
4. Place the upper assembly on the lightbar base and secure it with the four hex-head screws.

**Table 5** HighLighter LED Flash Patterns

No.	Description	Rate	Compliance
1*	FedPulse Quad Flash (default pattern)	96 FPM	SAE/NFPA/T13
2	2X Flash	80 FPM	SAE/NFPA/T13
3	Quad Flash	73 FPM	SAE/NFPA/T13
4*	Decelerating 10X Flash	60 FPM	SAE/NFPA/T13
5*	7X Flash All	81 FPM	SAE/NFPA/T13
6*	Quad Flash All	80 FPM	SAE/NFPA/T13
7	Quad Flash L/R-Front/Back	74 FPM	SAE/NFPA/T13
8*	Double/Quad	84 FPM/79 FPM	SAE/NFPA/T13
9*	Single/Double/Quad	91 FPM	SAE/NFPA/T13
10**	Split Quad Flash	60 FPM	SAE/NFPA
11**	Split Triple Flash	85 FPM	SAE/NFPA
12	Continuous Flash	75 FPM	SAE/NFPA/T13
13	Continuous Flash	120 FPM	SAE/NFPA/T13
14*	2X Flash	91 FPM	SAE/NFPA/T13
15	Single Flash L/R-Front/Back	92 FPM	SAE/NFPA/T13
16	Double Flash L/R-Front/Back	84 FPM	SAE/NFPA/T13
17*	FedPulse Triple Flash	117 FPM	SAE/NFPA/T13
18	Random Patterns 1-9	--	SAE/NFPA/T13
19	Random Patterns 1-5, 7-9, 12-14, 17	--	SAE/NFPA/T13
20	Rotate Counter Clockwise (This pattern is Sweep for Standard model.)	180 RPM	SAE/NFPA/T13
21	Rotate Clockwise (This pattern is Sweep for Standard model.)	180 RPM	SAE/NFPA/T13
22	Steady Test Pattern with Dim	--	SAE/NFPA/T13
23	Advanced Sync Pattern: Pulse if missing Sync after 1.1 second; DIM if on > 600 ms	--	SAE/NFPA/T13

\* In the Pro Model the pattern does not have a high-side SYNC OUT 2 or HSD 2 .

\*\* The center lightheads in the Standard and Pro models are not used in this pattern.

## Cleaning the Domes

Periodically cleaning the domes using proper procedures and compatible cleaners will prolong their service life.

**⚠ WARNING**

***CRAZING/CHEMICALS: Crazed, cracked or faded domes or reflectors reduce the light output and the effectiveness of the lighting system. Tops or reflectors showing this type of aging must be replaced. Failure to follow this warning may result in bodily injury or death to you or others.***

**⚠ WARNING**

***CRAZING/CLEANING SOLUTIONS: The use of cleaning solutions, such as strong detergents, solvents, and petroleum products, can cause crazing (cracking) of the domes and reflectors. Failure to follow this warning can damage the domes and reflectors and may result in bodily injury or death to you or others.***

To clean the domes:

1. Rinse the domes with lukewarm water to loosen dirt and debris.
2. Use a mild soap, lukewarm water, and a soft cloth to gently clean the plastic surfaces. To avoid damaging the reflectors, do not use heavy pressure or caustic, abrasive, or petroleum-based cleaners.
3. Rinse and dry the plastic surfaces with a soft cloth to prevent water spotting.

To remove fine scratches and haze, use a specialty plastic cleaner/polish such as Plexus® and a soft cloth. You can also use a high quality automotive paste cleaner/wax that is non-abrasive.

## Ordering Replacement Parts

To order replacement parts, call the Federal Signal Service Department at 1-800-433-9132 or 1-708-534-3400, 7 A.M. to 5 P.M., Monday through Friday (Central Time) or contact your nearest distributor.

## Getting Technical Support and Service

For technical support and service, please contact:

Service Department  
Federal Signal Corporation  
Phone: 1-800-433-9132  
Fax: 1-800-343-9706  
Email: [empserviceinfo@fedsig.com](mailto:empserviceinfo@fedsig.com)

## **Returning a Product to Federal Signal**

Before returning a product to Federal Signal, call 800-264-3578 (Mobile Systems) or 800-433-9132 (Service) to obtain a Returned Merchandise Authorization number (RMA number). To expedite the process please be prepared with the following information:

- Your Federal Signal customer or account number
- The purchase order number under which the items were purchased
- The shipping method
- The model or part number of the product being returned
- The quantity of products being returned
- Drop ship information as needed
- Any estimate required

When you receive your RMA Number:

- Write the RMA number on the outside of the box of returned items
- Reference the RMA number on your paperwork inside of the box
- Write the RMA number down, so that you can easily check on status of the returned equipment

Send all material with the issued RMA Number to:

Federal Signal Corporation  
Public Safety Systems  
2645 Federal Signal Drive  
University Park, IL 60484-3167  
Attn: Service Department  
RMA: # \_\_\_\_\_

800-433-9132  
800-343-9706 (fax)  
www.fedsig.com





2645 Federal Signal Drive, University Park, IL 60466-3195

Tel.: (800) 264-3578 • Fax: (800) 682-8022

[www.fedsig.com](http://www.fedsig.com)

© 2014 Federal Signal Corporation