

Control Panels

B5512/B4512



BOSCH

Table of contents

1	Introduction	4
1.1	About documentation	4
1.1.1	Related documentation	4
1.2	Bosch Security Systems, Inc. product manufacturing dates	5
2	System overview	6
3	Control panel installation	7
3.1	Install the enclosure and wiring label	7
3.2	Install the control panel	7
3.2.1	Mount the control panel	7
3.2.2	Connect earth ground	9
3.2.3	Configure OUTPUT A using the jumper	9
3.3	Control panel to module wiring overview	10
4	Power supply	11
4.1	Primary power terminals	11
4.1.1	Install the transformer	12
4.2	Secondary (DC) power terminals	12
4.2.1	Install the battery	12
4.2.2	Battery maintenance	14
4.2.3	Battery supervision	14
4.2.4	Battery discharge and recharge schedule	14
4.3	B520 Auxiliary Power Supply	15
4.3.1	SDI2 address settings	15
4.3.2	Supervision	15
4.3.3	Auxiliary power supply trouble conditions	15
4.3.4	Installation and control panel wiring (B520)	16
4.3.5	Powered device and battery wiring	17
5	On-board outputs	18
5.1	Powered outputs	18
5.1.1	Circuit protection	18
5.1.2	Total available power	19
5.2	Open collector outputs	19
6	Control panel board overview	20
7	System wiring diagrams	21
7.1	System wiring overview	21
7.2	Battery lead supervision wiring	23
7.3	Notification appliance circuit wiring	23
7.4	Keyswitch wiring	25
7.5	SDI2 devices general system wiring	26
7.5.1	SDI2 bus wiring recommendations	26
7.6	Wiring label	30
8	Specifications	31
8.1	Wire requirements	32

1 Introduction

1.1 About documentation

This document contains instructions for a trained installer to properly install, configure, and operate this control panel, and all optional peripheral devices. Review this document before beginning the installation to determine the hardware and wiring requirements for the features used.

Throughout this document, the words “control panel” refer to both control panels (B5512 and B4512).

Notifications

This document uses Notices, Cautions, and Warnings to draw your attention to important information.



Notice!

These are important notes for successful operation and programming of equipment.



Caution!

These caution you that physical damage to the program and/or equipment might occur if you do not follow the instructions.

Warning!

These warn you of an increased risk of physical damage to the equipment or to you if you do not follow the instructions

Copyright

This document is the intellectual property of Bosch Security Systems, Inc. and is protected by copyright. All rights reserved.

Trademarks

All hardware and software product names used in this document are likely to be registered trademarks and must be treated accordingly.

1.1.1

Related documentation

To obtain any of the documents listed in this section, download them from the web.

Downloading documentation:

1. Go to the Bosch Web site (<http://www.boschsecurity.us/en-us/>).
2. Under **Online Catalogs**, click **Online Product Catalogs**.
3. Under **Product Categories**, click **Intrusion Alarm Systems**.
4. Under **Search** on the right side, click in the **Product Search** text box.
5. Enter the CTN for the product for which you wish to download the documentation.
6. Click **Start search**.

7. Under **Search Results**, click the desired product. The product page opens with the **Documents** tab selected.
 8. Click **en** to the right of the desired document.
- Call Bosch Security Systems, Inc., Technical Support (1-800-289-0096) if you need additional assistance.

Control panel documents

<i>Control Panels (B5512/B4512) Release Notes (P/N: F01U265447)*</i>
<i>Control Panels (B5512/B4512) Installation and System Reference Guide (P/N: F01U265444)*</i>
<i>Control Panels (B5512/B4512) Owner's Manual (P/N: F01U265453) * *</i>
<i>Control Panels (B5512/B4512) Program Entry Guide (P/N: F01U265465)*</i>
<i>Control Panels (B5512/B4512) UL Installation Guide (this document) (P/N: F01U265448)* *</i>
<i>Control Panels (B5512/B4512) SIA Quick Reference Guide (P/N: F01U265466)* *</i>
*Shipped with the control panel. *Located on the documentation CD shipped with the control panel.

Keypad documents

<i>Two-line Alphanumeric Keypad (B920) Installation Guide (P/N: F01U265450)*</i>
<i>ATM Style Alphanumeric Keypad (B930) Installation Guide (P/N: F01U265451)*</i>
*Shipped with the keypad.

Optional module documents

<i>Octo-input Module (B208) Installation and Operation Guide (P/N: F01U265456)*</i>
<i>Octo-output Module (B308) Installation and Operation Guide (P/N: F01U265458)*</i>
<i>Ethernet Communication Module (B426) Installation and Operation Guide (P/N: F01U266226)* *</i>
<i>Plug-in Telephone Communicator (B430) Installation Guide (P/N: F01U265454)*</i>
<i>Conettix Plug-in Cellular Communicator (B440) Installation and Operation Guide (P/N: F01U265455)*</i>
<i>Auxiliary Power Supply (B520) Installation and Operation Guide (P/N: F01U265445)*</i>
<i>RADION receiver SD (B810) Installation Guide (P/N: F01U261834)*</i>
<i>SDI2 Inovonics Interface Module (B820) Installation Guide (P/N: F01U265460)*</i>
*Shipped with the module. *Located on the documentation CD shipped with the module.

1.2 Bosch Security Systems, Inc. product manufacturing dates

Use the serial number located on the product label and refer to the Bosch Security Systems, Inc. web site at <http://www.boschsecurity.com/datecodes/>.

The following image shows an example of a product label and highlights where to find the manufacturing date within the serial number.

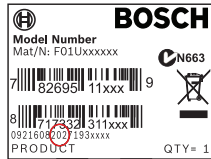

2 System overview

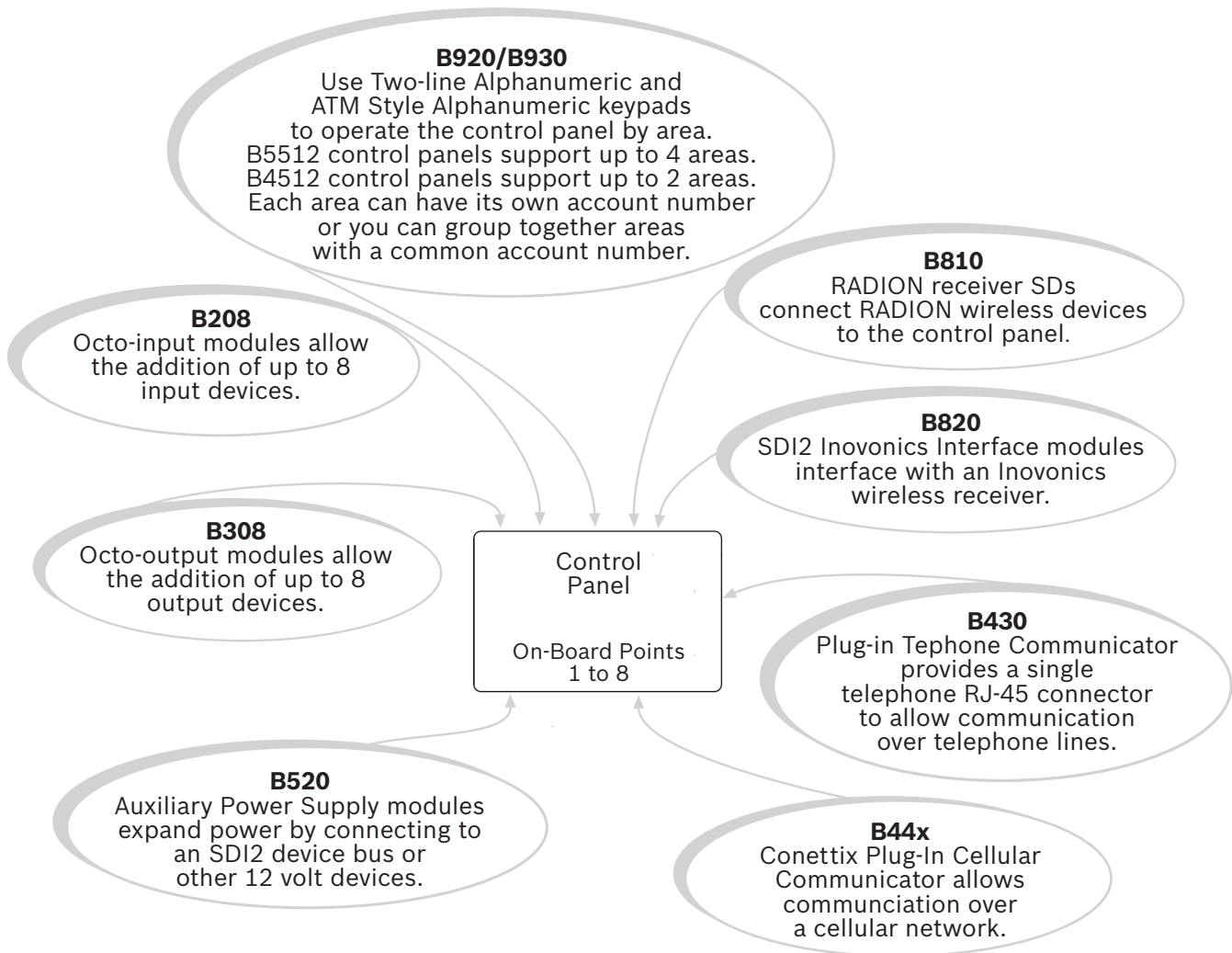

3 Control panel installation

3.1 Install the enclosure and wiring label

Refer to Enclosures to determine if the application requires a specific enclosure.

To install the enclosure:

1. Remove any knockouts prior to installing the control panel.
2. Mount the enclosure in the desired location. Use all enclosure mounting holes. Refer to the mounting instructions supplied with the selected enclosure.
3. Pull the wires into the enclosure.



Notice!

Electromagnetic interference (EMI) can cause problems on long wire runs.

4. Install the supplied *B5512/B4512 Enclosure Wiring Label* (P/N: F01U265449) on the inside of the enclosure door.

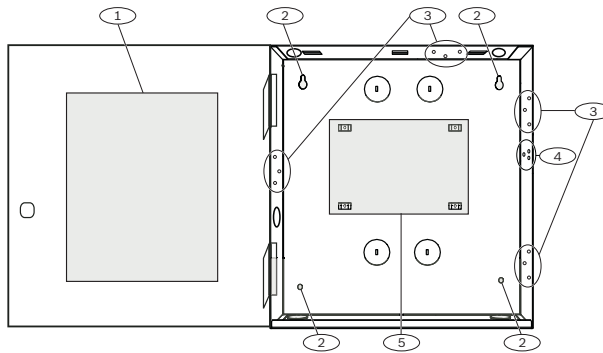

Figure 3.1: Enclosure and control panel mounting (B10 shown)

1 — Control panel wiring label
2 — Enclosure mounting holes (4)
3 — Module mounting locations (4)
4 — Tamper switch mounting location
5 — Control panel mounting location

3.2 Install the control panel

3.2.1 Mount the control panel

1. Identify the control panel mounting location in the enclosure.

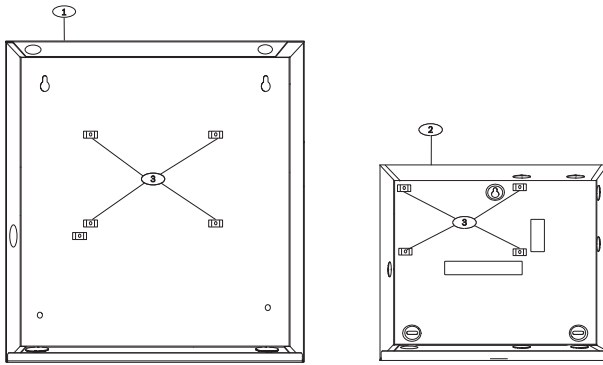

Figure 3.2: B10 and B11 control panel placement locations

- | |
|---|
| 1 — B10 Medium Control Panel Enclosure |
| 2 — B11 Small Control Panel Enclosure |
| 3 — Mounting clip locations for the B5512/B4512 |

2. Snap the four supplied plastic standoffs onto four enclosure support posts. If using the B12 Mounting Plate for D8103 Enclosure, attach the standoffs to the plate support posts. Do not attach the standoffs with screws at this time.

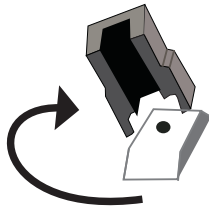

Figure 3.3: Standoff attachment

3. Place the control panel on top of the standoffs. Align the holes in the corners of the control panel with the openings at the top of each standoff. Secure the control panel to the standoffs with supplied, self-threading screws.

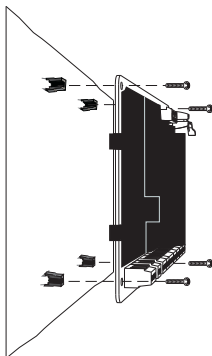

Figure 3.4: Mount control panel on standoffs

4. If using the B12 Mounting Plate for D8103 Enclosure, rest the hook tabs on the mounting plate hooks within the enclosure. Secure the lock-down tab to the plate mounting hole with the screw provided.

3.2.2 Connect earth ground

To help prevent damage from electrostatic discharges or other transient electrical surges, connect the system to earth ground at the earth ground terminal before making other connections. The ⚡ icon indicates the earth ground terminal. Use a recommended earth ground reference, such as a grounding rod or a cold water pipe.

**Notice!**

Do not use telephone or electrical ground for the earth ground connection. Use 14 AWG (1.8 mm) to 16 AWG (1.5 mm) wire when making the connection. Do not connect other control panel terminals to earth ground.

**Caution!**

Avoid electrostatic discharge. Always touch the earth ground connection with the ⚡ icon first, before beginning work on the control panel.

3.2.3 Configure OUTPUT A using the jumper

When planning your installation, carefully consider the use of OUTPUT A. OUTPUT A is a form C relay. You can configure the common terminal (C) of Output A (OUTPUT A) using the jumper:

- To provide +12 VDC (AUX power)
- To be a COM terminal (parallel to all COM terminals)
- To be a dry contact (no voltage, not common)

The control panel ships with the jumper in the default position, AUX power. (OUTPUT A, 'C' terminal using AUX PWR). Remove the door covering the jumper pins, and then move the jumper to the left two pins for switched low (OUTPUT A parallel to COM terminals). Replace the cover door. The OUTPUT A LED lights when OUTPUT A is active. Refer to the figure below or to the *B5512/B4512 Enclosure Wiring Label* (P/N: F01U265442) to set the OUTPUT A jumper.

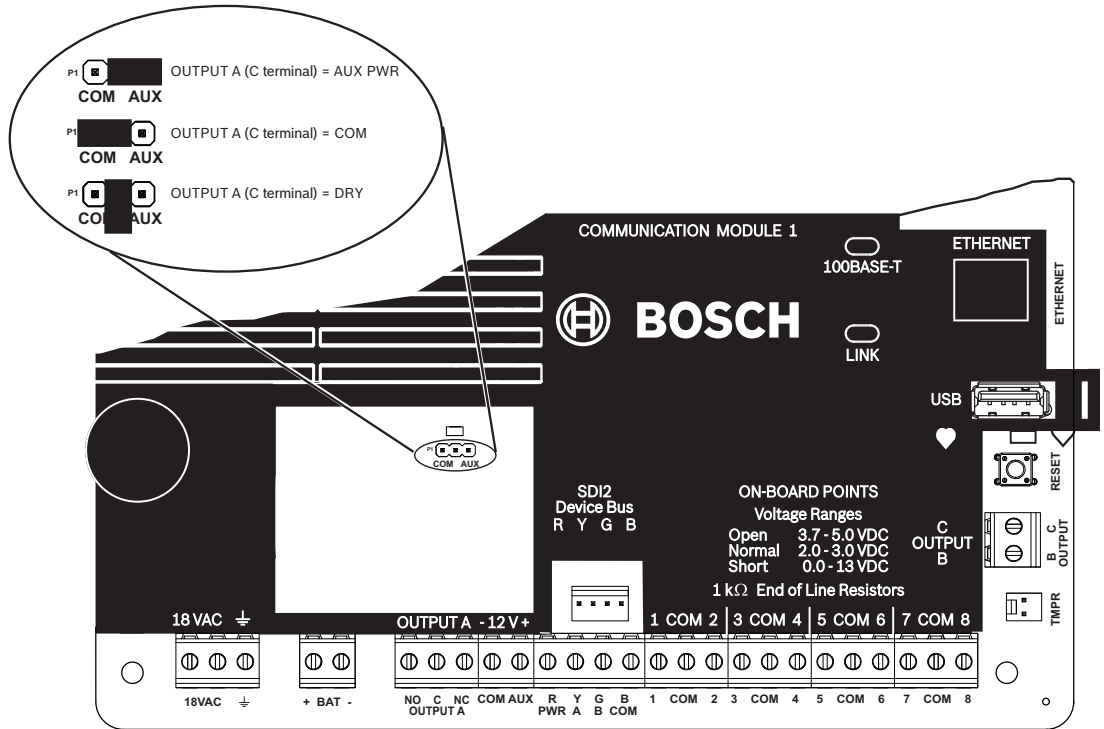

Figure 3.5: OUTPUT A jumper configuration options

3.3 Control panel to module wiring overview

In the following sections, this document provides instructions for wiring devices to your control panel. You can use interconnect or terminal wiring.

Using terminal wiring

For terminal wiring, use 18 AWG to 22 AWG (1.02 mm to 0.65 mm) wire.

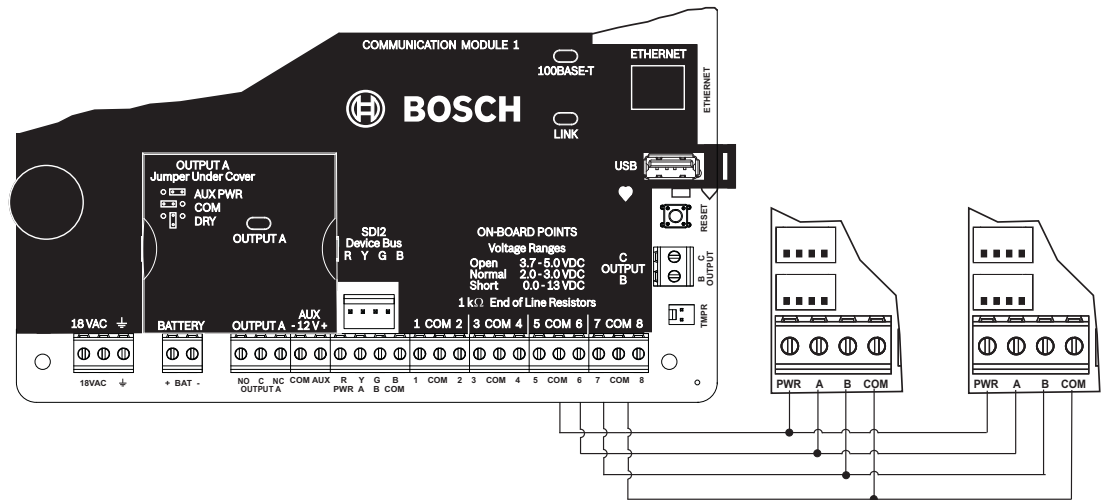

Figure 3.6: SDI2 devices daisy chained with terminal wiring

Using interconnect wiring

Interconnect wiring connectors parallel the SDI2 PWR, A, B, and COM terminals on the terminal strip. In installations with multiple SDI2 modules, using interconnect wiring makes the installation quicker and easier than using terminal strip wiring. You use any combination of terminal and interconnect wiring to wire multiple modules in parallel, but do not wire a single module to the control panel using both terminal and interconnect wiring. The interconnect wiring connectors are "keyed" (interconnect wiring plug can fit in only one direction).

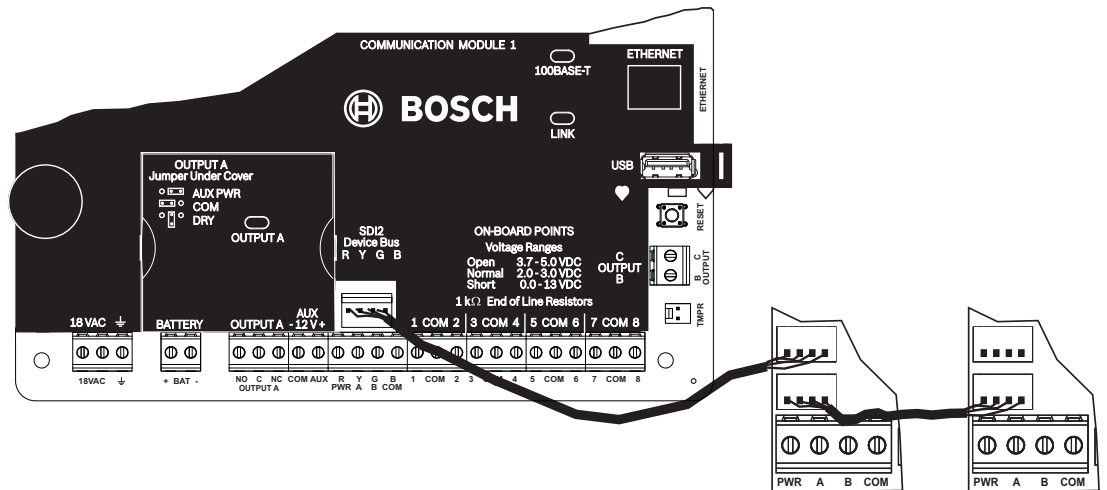

Figure 3.7: SDI2 devices daisy chained with interconnect wiring

4 Power supply

4.1 Primary power terminals

18VAC

The control panel uses an 18 VAC, 22 VA internally fused transformer (CX4010) for its primary power source. The control panel draws 125 mA when idle and 155 mA when in an alarm state. The auxiliary power available for continuously powered devices is 800 mA.

Transient suppressors and spark gaps protect the circuit from power surges. This protection relies on the ground connection at the earth ground terminal, marked with the ⚡ icon. Ensure that you connect the terminal to a proper ground.

Refer to *Connect earth ground*, page 9.

AC power fail

The system indicates an AC power failure when the 18 VAC terminals do not have power. The AC Fail Time parameter sets the number of minutes or seconds without AC power before the control panel reports the failure, and the number of minutes or seconds after the power returns before the control panel reports restored power.

Self diagnostics at power up and reset

The system performs a series of self-diagnostic tests of hardware, software, and programming at power up and at reset. The self-diagnostics tests complete in approximately 10 to 30 sec. If the control panel fails any test, a System Trouble message appears at the keypads.

4.1.1 Install the transformer

**Caution!**

Do not short-circuit the terminals of the transformer: Shorting the terminals opens the internal fuse, causing permanent failure. Connect the transformer to the 18 VAC terminals of the control panel before plugging it into the power source.

**Notice!**

Plan ahead

Route telephone, SDI2 bus wiring, and sensor loop wiring away from any AC conductors, including the transformer wire. AC wiring can induce noise and low level voltage into adjacent wiring.

1. Use 18 AWG (1.02 mm) wire minimum (12 AWG [2 mm] maximum) and connect the transformer to the control panel. Make the wire length as short as possible. Do not exceed 50 ft (15 m).
2. Connect the wire to the control panel.
3. Connect the wire to the transformer.
4. Plug the transformer into an unswitched, 120 VAC, 60 Hz power outlet only.
5. Secure the transformer to the outlet with the screw provided.

**Notice!**

The transformer screw is not present on the Canadian (cUL) transformer.

4.2 Secondary (DC) power terminals

+ BAT -

A 12 V sealed lead-acid rechargeable battery (D126/D1218) supplies secondary power for auxiliary and alarm outputs, and powers the system during interruptions in primary (AC) power.

**Notice!**

Use Lead Acid Batteries Only: The charging circuit is calibrated for lead-acid batteries. Do not use gel-cell or nicad batteries.

Extra batteries increase back-up time

To increase battery back-up time, connect a second 12 V battery in parallel to the first battery. Use a D122 Dual Battery Harness to ensure proper and safe connection. Refer to Standby battery calculations.

D1218 Battery

The D1218 is a 12 V, 18 Ah battery for use in applications requiring extended battery standby time. The control panel does not support more than 18 Ah.

4.2.1 Install the battery

1. Place the battery upright in the base of the enclosure.
2. Locate the red and black leads supplied in the literature pack.

3. Connect the black battery lead to the BAT- terminal, and then to the negative (-) side of the battery.
4. Connect the red battery lead to the BAT+ terminal, and then to the positive (+) side of the battery.

Warning!

High current arcs are possible. The positive (red) battery lead and the BAT+ terminal can create high current arcs if shorted to other terminals or the enclosure. Use caution when working with the positive lead and BAT+. Always disconnect the positive (red) lead from the battery before removing it from BAT+.



Caution!

The battery terminals and wire are not power limited. A 0.250 in (6.4 mm) space must be maintained between the battery terminals, battery wiring, and all other wiring. Battery wiring cannot share the same conduit, conduit fittings, or conduit knockouts with other wiring.

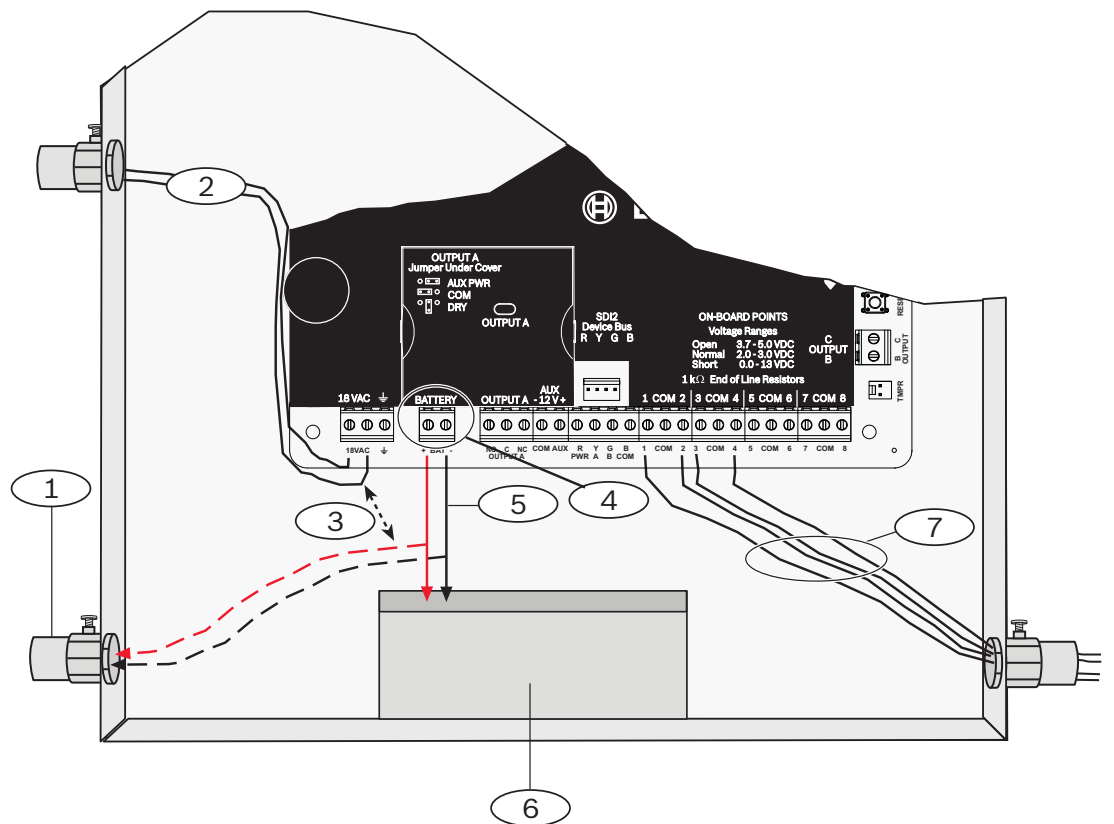

Figure 4.1: Non-power-limited wiring

Callout — Description
1 — Conduit required for use with external batteries
2 — To CX4010 UL Listed Class 2 Transformer 18 VAC 22 VA 60 Hz
3 — 0.25 in (6.4 mm) minimum
4 — Battery terminals. BAT- is non-power limited
5 — Battery wires

Callout — Description
6 — 12 V sealed lead-acid rechargeable battery (D126/D1218)
7 — Sensor loop wires

Charge the battery

Connect the battery and then the transformer to allow the control panel to charge the battery while you complete the installation.

4.2.2

Battery maintenance

Use sealed lead-acid rechargeable battery (12.0 VDC, 7 Ah or 12.0 VDC, 18 Ah). The control panel supports up to 18 Ah of battery. If you use two D126 (12.0 VDC, 7 Ah) batteries, then connect them using the D122/D122L Dual Battery Harness. If you install two batteries, they must have the same capacity.

Replace the batteries every 3 to 5 years. If you install two batteries, replace them both at the same time.

Record the date of installation directly on the battery.



Caution!

Exceeding the maximum output ratings or installing the transformer in an outlet that is routinely switched off causes heavy discharges. Routine heavy discharges can lead to premature battery failure.

4.2.3

Battery supervision

The battery charging float level occurs at 13.65 VDC. If the battery voltage drops below 12.1 VDC, the control panel sends a LOW BATTERY report, if programmed to do so.

When the battery voltage drops to 10.2 VDC, the keypad or keypads show low battery messages. The control panel (if programmed for power supervision) sends a Battery Low report in the Modem4 communication format. It sends a Low System Battery (302) report in the Contact ID format.

If programmed for power supervision, the control panel adds a missing battery event to the event log. If programmed for battery fault reports, the control panel sends a BATTERY MISSING report in the Modem4 communication format, or Control Panel Battery Missing (311) report in the Contact ID format.

When battery voltage returns to 13.4 V, the keypads stop showing the low battery messages. If the control panel is programmed for power supervision, it sends a BATTERY RESTORAL report in the Modem4 communication format or a Control Panel Battery Restored to Normal (302) report in the Contact ID format.

Investigate LOW BATTERY events immediately: If primary (AC) power is off and the discharge continues, the control panel becomes inoperative when the battery voltage drops below 10.2 VDC.

4.2.4

Battery discharge and recharge schedule

Discharge cycle

13.65 VDC - Charging float level.

12.1 VDC - Low Battery Report, if programmed.

10.2 VDC - Minimum operational voltage.

Recharge cycle

AC ON - Battery charging begins and AC Restoral Reports sent.
13.4 V - Battery Restoral Report sent. Battery float charged.

Further information

Refer to *Powered outputs*, page 18.

4.3 B520 Auxiliary Power Supply

The optional B520 Auxiliary Power Supply Module provides up to 2 A of 12 VDC standby power for Fire and Burglar applications. For Burglar applications, an additional 2 A of alarm power is available, allowing 2 A of standby current and up to 4 A of alarm current. You can connect more than one module to the control panel.

The B5512 control panel supports up to 4 modules, while the B4512 supports up to 2 modules.

Connect B520 Auxiliary Power Supply Modules to the SDI2 bus on the control panel using terminals PWR, A, B, and COM. This section includes basic installation instructions. Refer to the *Auxiliary Power Supply Module (B520) Installation Guide* (P/N: F01U215240) for complete installation instructions and for the *B520 Auxiliary Power Supply Module Battery Standby Chart* for battery standby time calculations.

4.3.1 SDI2 address settings**Notice!**

The module reads the address switch setting only during power up. If you change the switches after you apply power to the module, you must cycle the power to the module in order for the new setting to be enabled.

For single-digit address numbers 1 to 9, set the tens switch to 0 and the ones digit to the appropriate number. If multiple B520 modules reside on the same system, each B520 module must have a unique address.

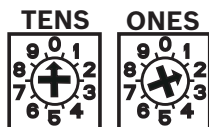

Figure 4.2: Address switches set to 2

4.3.2 Supervision

The control panel supervises B520 Auxiliary Power Supply Modules on the SDI2 bus.

With any failure to receive an expected response from an SDI2 module, all keypads show in a system fault display. The control panel sends a module trouble report to the central station (if configured for module trouble reports).

4.3.3 Auxiliary power supply trouble conditions

Each auxiliary power supply module on the SDI2 bus monitors several conditions including AC status, battery status, over current status, and a tamper input. Each of these conditions produces a unique system trouble condition at all keypads. The control panel sends a module trouble report to the central station (if configured for module trouble reports).

When the control panel shows a generic trouble condition for a SDI2 bus power supply module, it could mean one of several non-serviceable things has occurred; low power output, module firmware flash error, or battery charger circuit failure.

4.3.4 Installation and control panel wiring (B520)

The power supply draws approximately 15 mA (+/- 1 mA) from the control panel.

Ensure that there is enough power for the module and other powered devices you want connected to the system.

Refer to *On-board outputs*, page 18.



Caution!

Always power down the control panel and B520 when connecting modules, relays, or other wiring. Power down the control panel and the B520 by unplugging their transformers and disconnecting their batteries.

Install the module

1. Install the enclosure on the wall using the instructions supplied with the enclosure.
2. Set the module address using the address switches before you install it in the enclosure.
3. Insert the plastic mounting clips onto the appropriate standoff locations inside the enclosure or on a mounting skirt, when required.
4. Mount the module onto the plastic mounting clips and then secure it using the supplied mounting screws.

Wire to earth ground

To help prevent damage from electrostatic charges or other transient electrical surges, connect the system to earth ground before making other connections. Recommended earth ground references are a grounding rod or a cold water pipe. When grounding, run wire as close as possible to grounding device.



Caution!

Do not use telephone or electrical ground for the earth ground connection. Use 14 AWG (1.8 mm) to 16 AWG (1.5 mm) wire when making the connection.

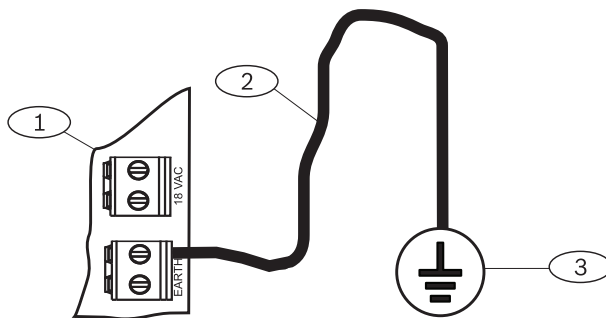

Figure 4.3: B520 earth ground wiring

Callout	Description
1	Power supply module
2	14 AWG - 16 AWG (1.8 mm - 1.5 mm) wire
3	Ground device (grounding rod or cold water pipe)

Wire to the control panel

When wiring a module to a control panel, use the terminal strip labeled with PWR, A, B, and COM for SDI2 IN to wire to terminals labeled PWR, A, B, and COM on the control panel. Use 12 AWG to 22 AWG (2 mm to 0.65 mm) wire.

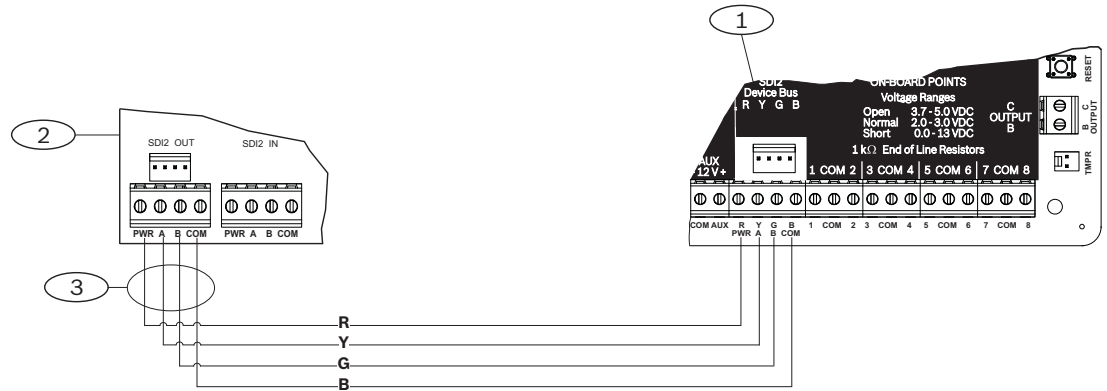

Figure 4.4: B520 to the control panel wiring

Callout	Description
1	Control panel
2	Power supply module
3	Terminal strip wiring

4.3.5

Powered device and battery wiring

Wire to SDI2 powered devices

When wiring the output of a B520 to a SDI2 module, you can use either the SDI2 OUT terminal strip labeled with PWR, A, B, and COM to wire to terminals labeled PWR, A, B, and COM on the next module, or you can use the interconnect wiring connector (included). Wiring the output of a B520 to a SDI2 device provides power to the device while passing through data between the control panel and the device.

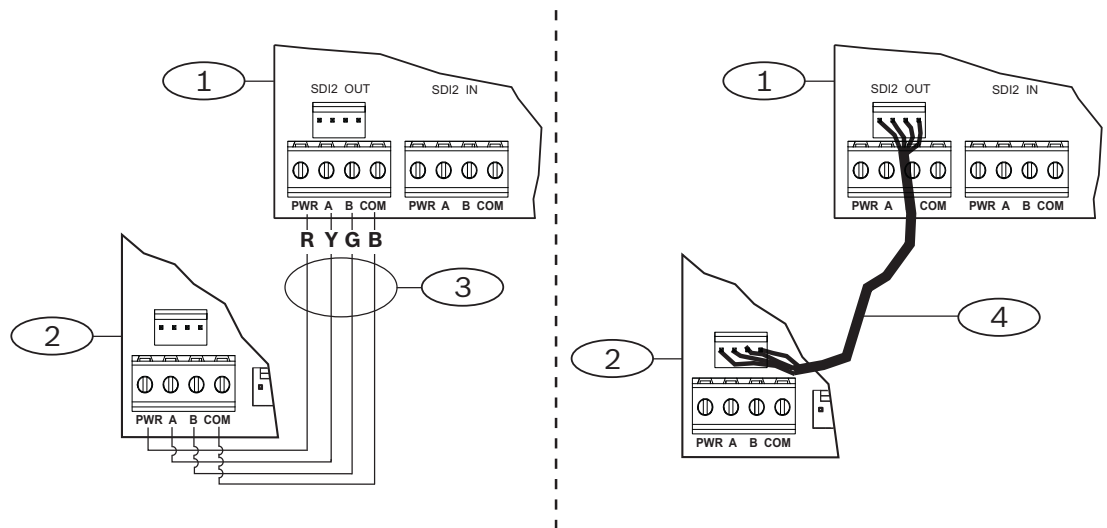

Figure 4.5: B520 to powered devices - terminal strip or interconnect wiring connector

Callout — Description
1 — B520 Auxiliary Power Supply Module
2 — Powered device (SDI2 module)
3 — Terminal strip wiring
4 — Interconnect wiring (P/N: F01U079745)

Wire to batteries

Wiring the B520 to BATT 1 is required for proper operation of standby power for the B520 module. Wiring the second battery (BATT 2) is optional. If a control panel is configured for two batteries as the standby power source, then BATT 2 is also required for proper operation. BATT 2 must have the same capacity and rating as BATT 1. Maximum standby power cannot exceed 36 Ah.

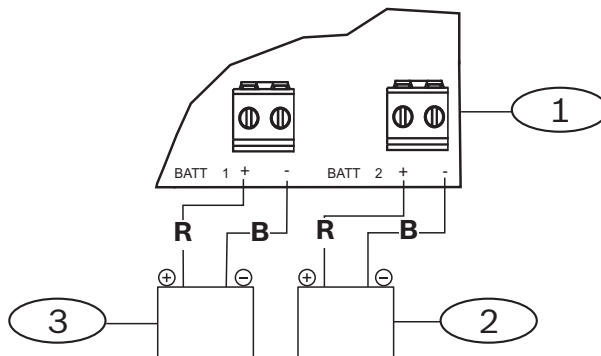

Figure 4.6: B520 BATT terminals wiring

Callout — Description
1 — Module
2 — Battery 2 (BATT 2) - (12 V nominal lead acid)
3 — Battery 1 (BATT 1) - (12 V nominal lead acid))

5 On-board outputs

5.1 Powered outputs

5.1.1 Circuit protection

Three self-resetting circuit breakers protect the control panel from short circuits on the continuous and programmable power outputs.

If programmed for power supervision, the control panel adds a missing battery event to the event log. If programmed for battery fault reports, the control panel sends a BATTERY MISSING report in the Modem4 communication format, or Control Panel Battery Missing (311) report in the Contact ID format.

One self-resetting circuit breaker protects the AUX (auxiliary power) terminal.

Another self-resetting circuit breaker protects the OUTPUT A's C terminal.

The third self-resetting circuit breaker protects PWR/R terminal (power) of the SDI2 terminal block.

**Notice!**

UL requires any device powered from a power output to be supervised.

5.1.2**Total available power**

The control panel produces up to 800 mA of combined power at 12.0 VDC nominal to power peripheral devices. The outputs listed below and OUTPUT A share the available power.

AUX terminal (auxiliary power)

Powers devices requiring continuous power (for example, motion detectors).

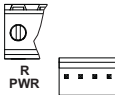
R/PWR terminal and power output of the interconnect connector (SDI2 power)

Power SDI2 devices such as a B208 Octo-input Module, a B308 Octo-output Module, or B920/B930 keypads.

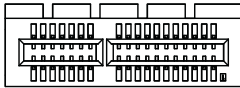
Plug-in module connector

Connect plug-in modules such as the B440 Conettix Plug-in Cellular Communicator.

OUTPUT A

Output A can be configured as a dry contact (contact rating is 3 Amps), switched common (sink current), or a powered output. As a powered output, it can provide alarm power or switched auxiliary power. The default configuration for Output A makes it a powered output providing alarm power. Use OUTPUT PARAMETERS in RPS to configure programmable outputs.

Refer to *Configure OUTPUT A using the jumper*, page 9.

5.2**Open collector outputs****OUTPUT B and C**

Outputs B and C are open collector outputs that can sink up to 50 mA of power (+12 VDC), when activated.

As an example, the figure below shows using Outputs B and C to trigger the relays of a D134 Dual Relay Module.

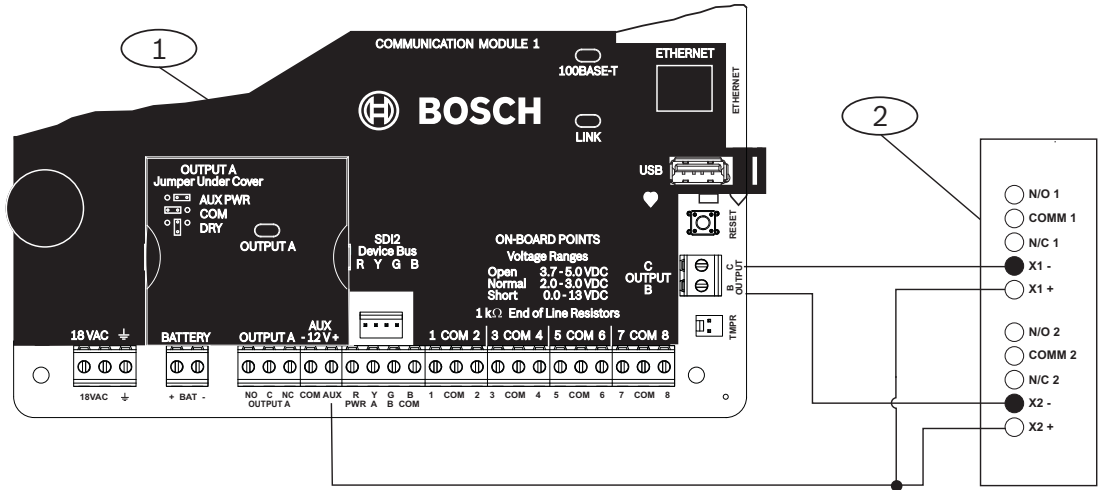

Figure 5.1: OUTPUT B and C wiring

Callout — Description
1 — Control panel
2 — D134 Dual Relay Module

Use OUTPUT PARAMETERS in RPS to configure programmable outputs.

6 Control panel board overview

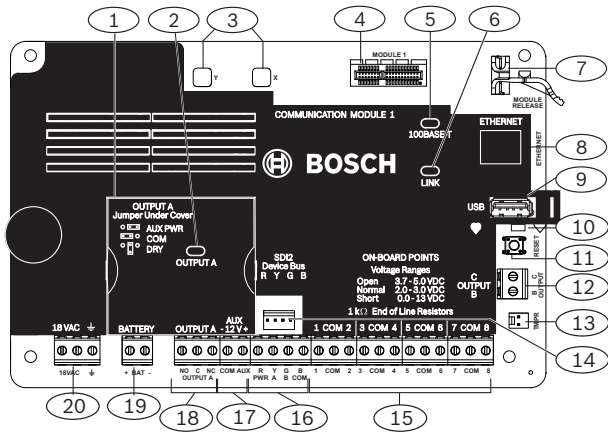

Figure 6.1: Control panel board overview

Callout — Description	Callout — Description
1 — Jumper cover. Remove to configure Output A	11 — RESET button
2 — OUTPUT A LED	12 — Terminals for Output B and Output C
3 — Holes to stabilize plug-on modules	13 — Tamper switch connector
4 — Plug-in module connector	14 — SDI2 interconnect wiring connector
5 — Green 100Mb LED	15 — Sensor loop terminals for points 1 to 8

Callout — Description	Callout — Description
6 — Yellow LINK LED	16 — SDI2 terminals (power and data)
7 — Plug-in module retention clip	17 — Auxiliary power terminals
8 — On-board Ethernet connector	18 — Terminals for Output A
9 — USB connector	19 — Battery terminals
10 — Heartbeat LED (blue)	20 — 18 VAC power input terminals

7 System wiring diagrams

7.1 System wiring overview



Notice!

For UL Certificated accounts, additional power can be obtained using only a UL Listed auxiliary 12.0 VDC regulated, power-limited power supply, such as the B520 Auxiliary Power Supply Module.

All terminals are power limited except BAT+ (battery positive).

All terminals are supervised except OUTPUT A, OUTPUT B, and OUTPUT C.

For proper supervision, do not loop wire under terminals. Break the wire run to provide supervision of connections.

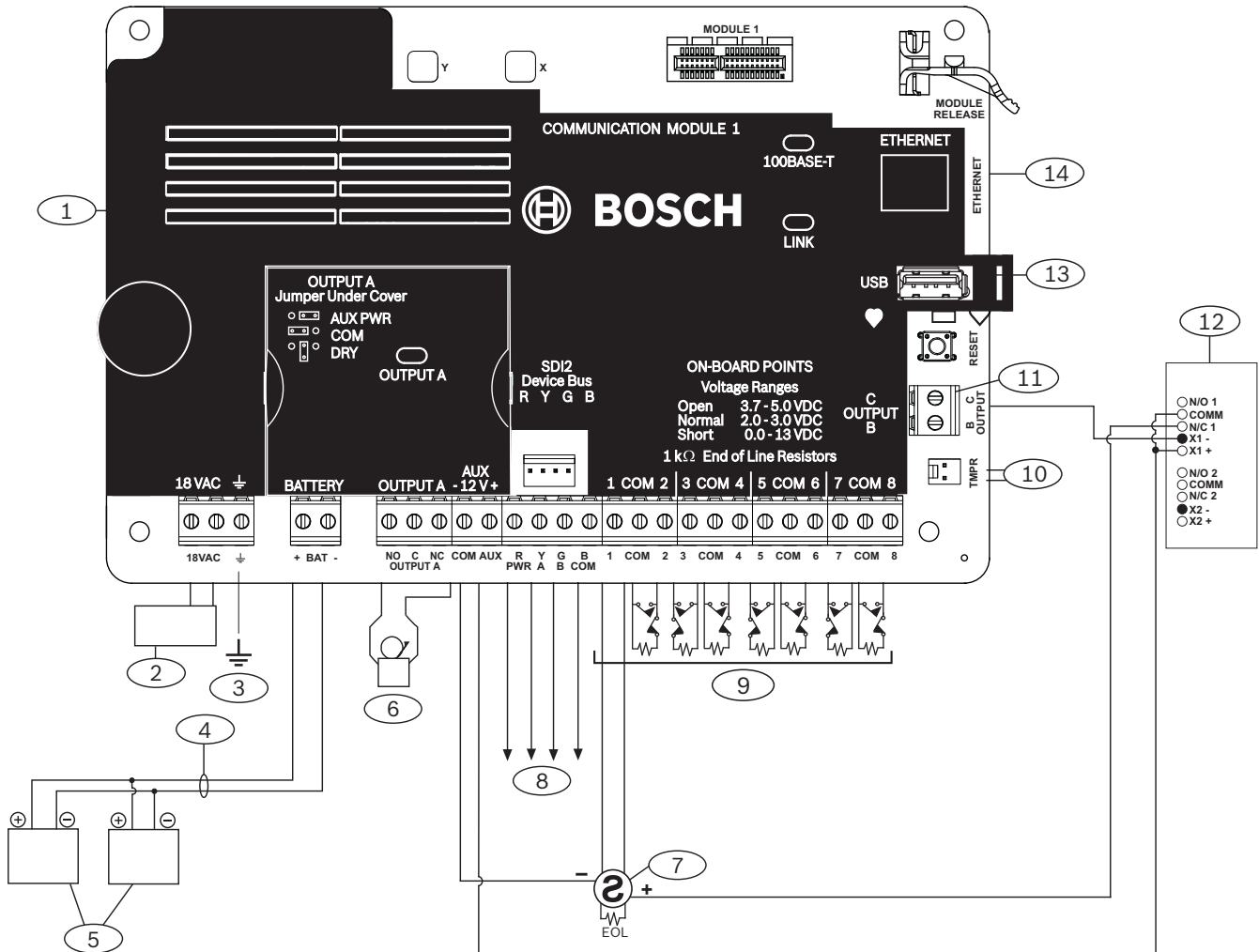

Figure 7.1: System wiring overview

Callout — Description	Callout — Description
1 — Control panel	8 — SDI2 wiring
2 — CX4010 UL Listed Class 2 Transformer 18 VAC 22 VA 60 Hz	9 — Supervised sensor loops, points 1 to 8 (Initiating Device Circuits)
3 — To earth ground	10 — To ICP-EZTS Tamper Switch
4 — D122/D122L Dual Battery Harness, as required	11 — Programmable outputs
5 — Batteries (Unsupervised)	12 — External relay
6 — Audible signaling device	13 — USB connector
7 — UL Listed four-wire smoke detectors with EOL resistor	14 — RJ-45 modular jack for Ethernet

7.2 Battery lead supervision wiring

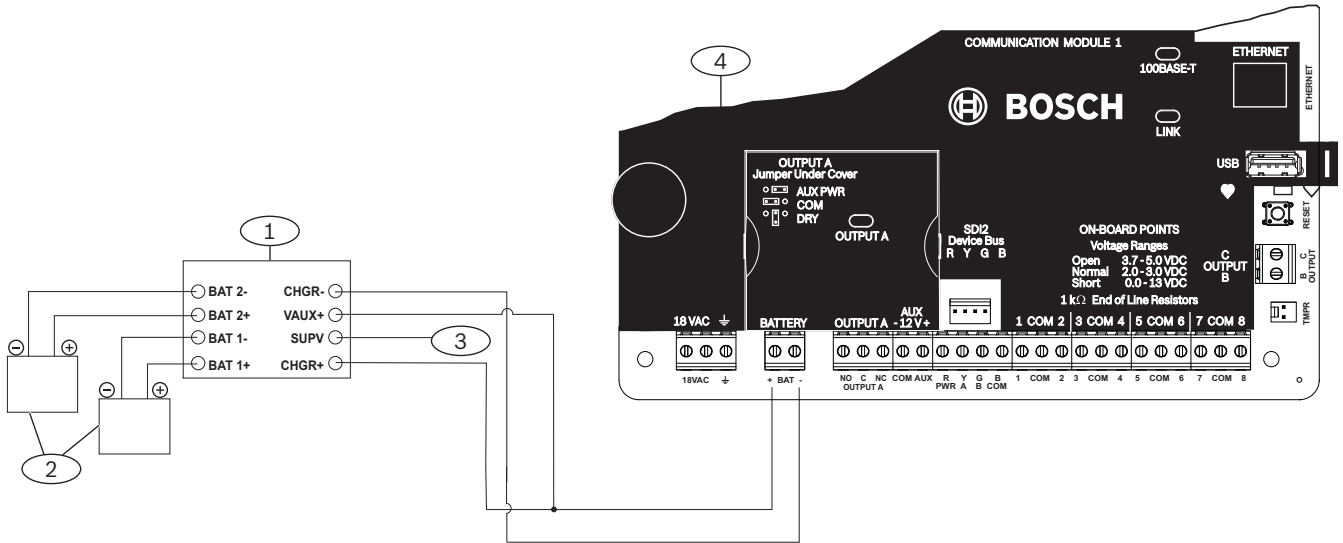

Figure 7.2: Battery supervision wiring

Callout	Description
1	D113 Battery Lead Supervision Module, if required
2	Batteries
3	To supervision point
4	Control panel

7.3 Notification appliance circuit wiring

The control panels do not have an onboard NAC. Programming determines the format of the output and the conditions that activate it. One self-resetting circuit breaker protects against shorts. When using the relay to activate notification appliance circuits in UL Listed fire alarm applications, install a D192G Notification Appliance Circuit module. Refer to the *D192G Notification Appliance Circuit Module Installation Guide* (P/N: 4998122260) for detailed wiring information and specifications.

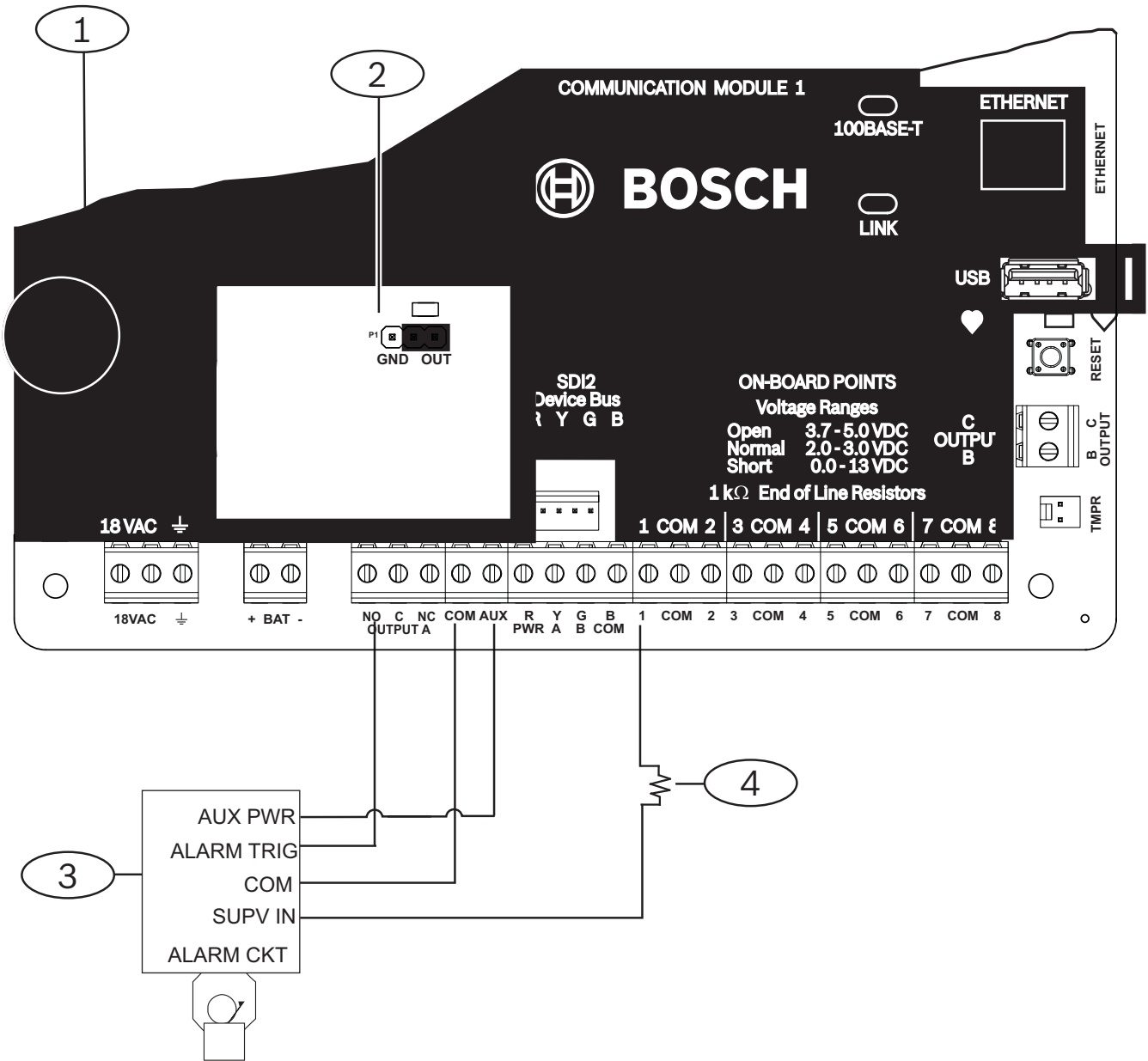

Figure 7.3: Notification appliance circuit wiring

Callout	Description
1	Control panel
2	Output jumper set to configure OUTPUT A terminal C for AUX POWER (jumper cover removed)
3	D192G Notification Appliance Circuit module
4	1k Ω EOL resistor (P/N: F01U033966)

7.4 Keyswitch wiring

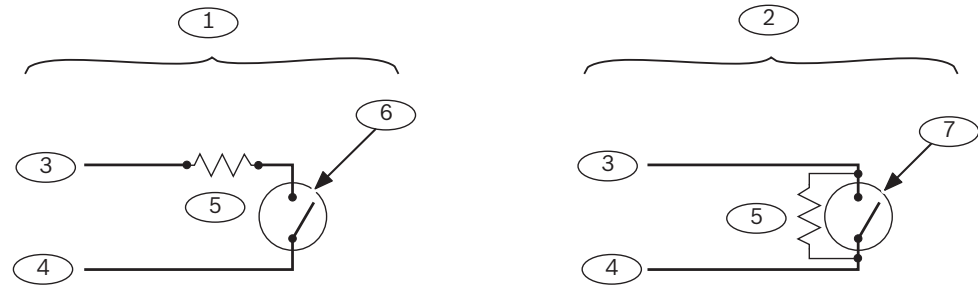

Figure 7.4: Keyswitch wiring

Callout — Description
1 — Maintained keyswitch
2 — Momentary keyswitch
3 — Common
4 — Point input
5 — 1 kΩ resistor (P/N: 4998143839)
6 — Open on a circuit arms the area
7 — Short on a circuit toggles the arming state

Keyswitches are not intended for use in UL listed systems.

7.5 SDI2 devices general system wiring

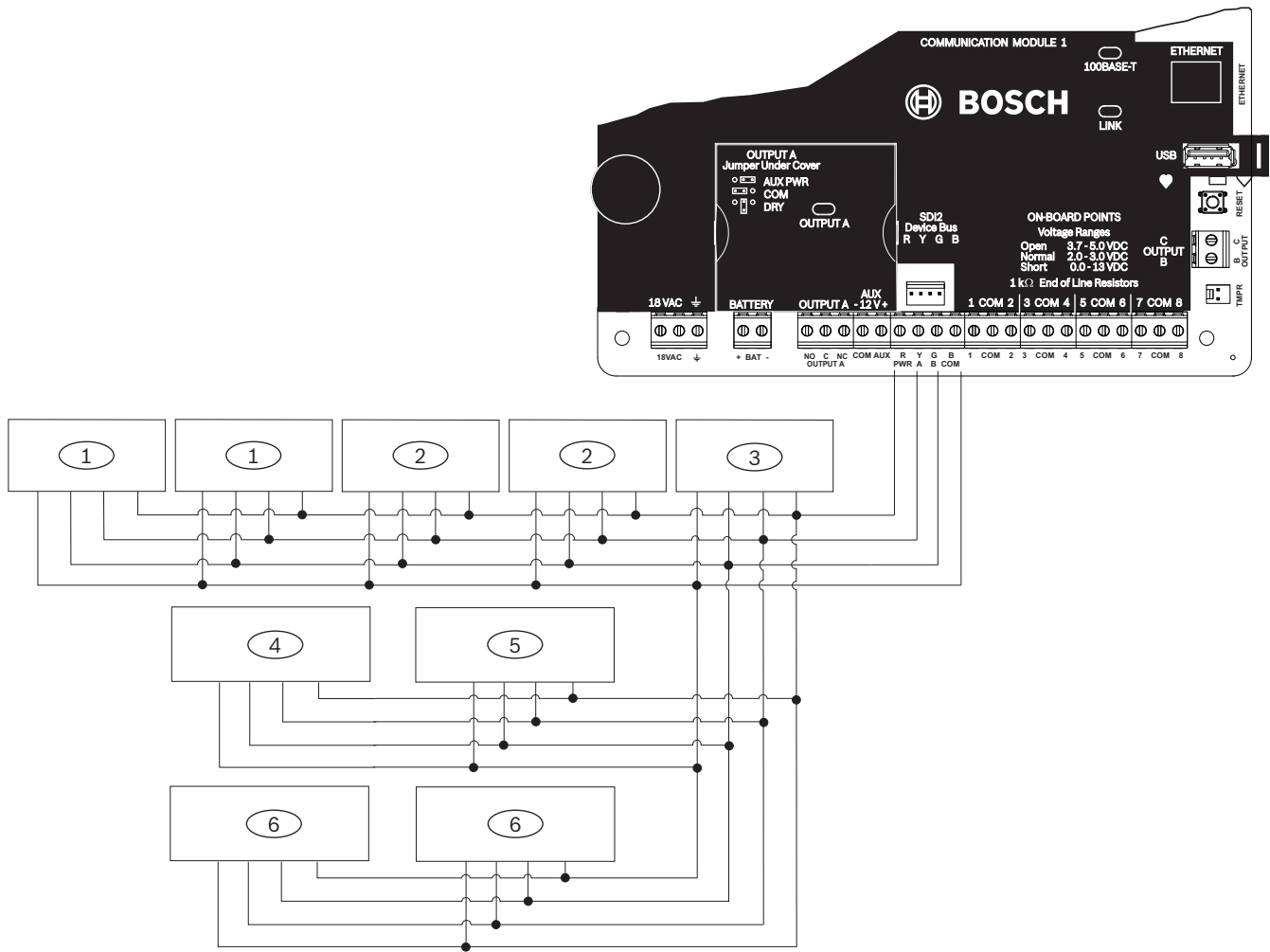

Figure 7.5: SDI2 devices system wiring

Callout — Description	B5512 Capacity	B4512 Capacity
1 — B208 Octo-input Module	4	2
2 — B308 Octo-output Module	5	3
3 — B426 Ethernet Communication Module	1	1
4 — B520 Auxiliary Power Supply Module	4	2
5 — B810 wireless receiver or B820 SDI2 Inovonics Interface Module	1	1
6 — B920 Keypad or B930 Keypad	8	8



Notice!

The SDI2 power terminal (R/PWR) is power limited. The SDI2 terminals are supervised.

7.5.1 SDI2 bus wiring recommendations

Use the following SDI2 bus wiring recommendations for SDI2 installation. The control panel and SDI2 modules use the SDI2 bus to communicate with one another.

You can configure modules via home run, daisy chain, or single level T-tap anywhere on the SDI2 bus.

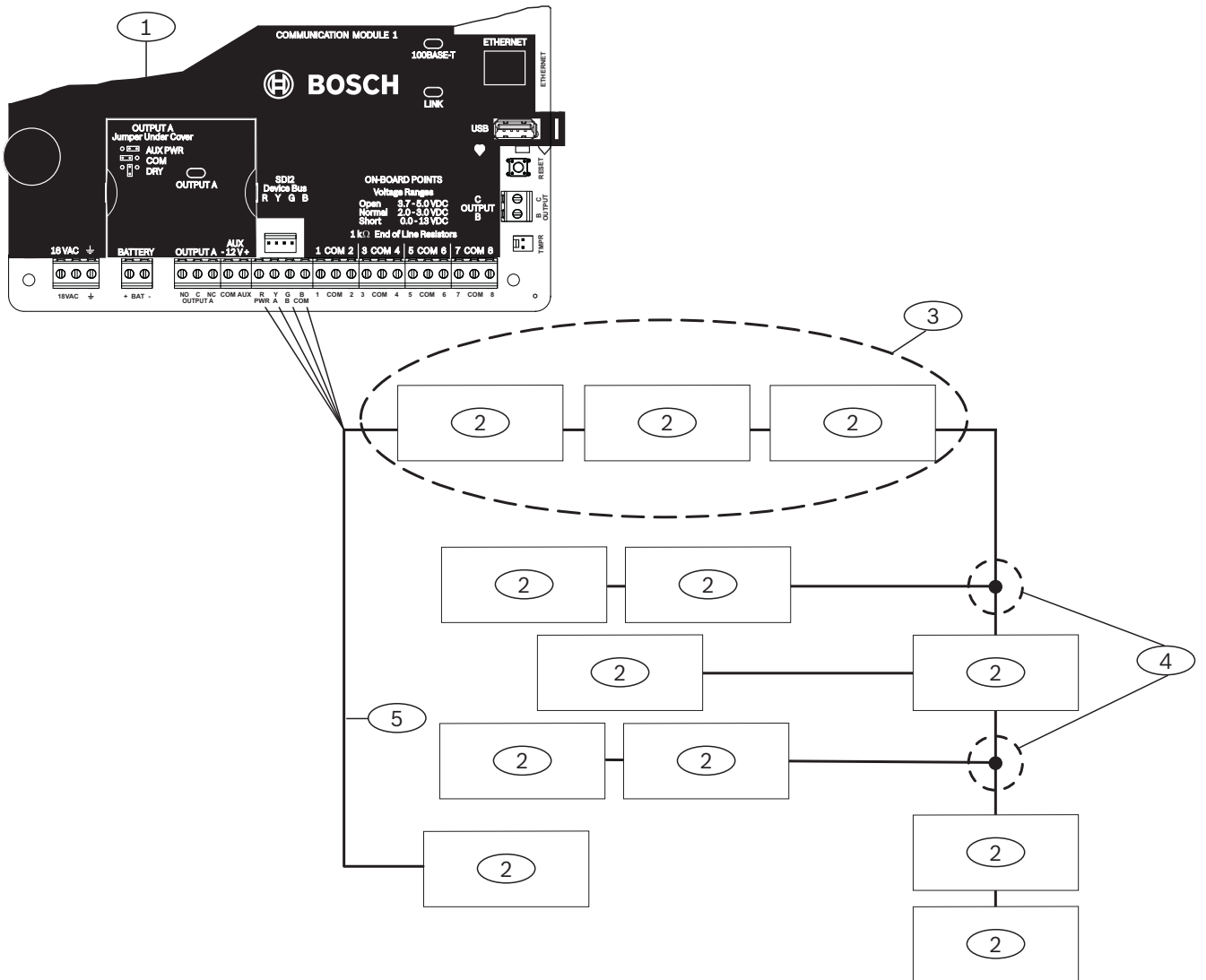

Figure 7.6: SDI2 bus wiring recommendations

Callout	Description
1	Control panel
2	SDI2 device (module or keypad)
3	Daisy chain wiring
4	Single-level T-tapped wiring
5	Home run wiring



Notice!

There can only be a difference of 2 volts (maximum) between the AUX power terminals of the control panel or power supply and the device for the modules and keypads to work properly under all conditions.

Maximum cable lengths

The following rules must be followed when wiring the SDI2 bus.

- The SDI2 bus requires the use of **un-shielded** cable from 12 AWG to 22 AWG.
- SDI2 devices or keypads must be within 2000 ft (610 m) of the control panel.
- Maximum overall cable lengths are listed in the following table:

Cable capacitance	Overall cable length	Cable capacitance	Overall cable length	Cable capacitance	Overall cable length	Cable capacitance	Overall cable length
pF/ft	ft	pF/ft	ft	pF/ft	ft	pF/ft	ft
< 17	7500	22	6363	27	5185	32	4400
18	7500	23	6086	28	5000	33	4242
19	7350	24	5800	29	4828	34	4100
20	7000	25	5600	30	4700	35	4000
21	6666	26	5385	31	4516	36	3800

Table 7.1: Maximum cable length



Notice!

Use unshielded cable only.

Maximum capacitance of 140nF (140,000 pF) per system. Contact the wire manufacturer for the capacitance ratings of the wire being used.

Example cable types

AWG	MFG/PN	Capacitance pF/ft	Resistance Ω /1000 ft	Max Run	NEC Type	Definition
22	Belden 5541	18	16.3	7500	CL3P, CL3R, CL3, CL3X, CL2P, CL2, CL2R, CL2X, CM	Class 2 and Class 3 remote control, communications, signaling and power limited cables
	Belden 1242	15	17.6	7500		
	Belden 5502	20	16.2	7000		
	Belden 5522	19	15.7	7350		
18	Belden 5302	22	6.5	6363		
	Belden 1242	15	17.6	7500		

AWG	MFG/PN	Capacitance pF/ft	Resistance Ω /1000 ft	Max Run	NEC Type	Definition
16	Belden HC2758	19.9	4.0	7000		
	Belden 5202	23.5	4.2	5800		
12	Belden 5002	32	1.56	4400		

Table 7.2: Maximum cable length



Notice!

Fire alarm applications require NEC cable type FPLR, FPLP, or FPL or the equivalent power limited fire alarm cables (refer to article 760 of the NFPA 70 code).

7.6 Wiring label



BOSCH

B5512/B4512

This equipment should be installed in accordance with the NFPA 70 (National Electrical Code), the NFPA 72 (National Fire Alarm Code), and the local authority having jurisdiction. Depending on the application, the installation is to be in accordance with one or more of the following UL standards: UL681 Installation and Classification of Mercantile and Bank Burglar Alarm Systems; UL1076 Proprietary Burglar Alarm Systems and Units; UL1641 Installation and Classification of Residential Burglar Alarm Systems. Printed information describing proper installation, operation, testing, maintenance, repair service and response to an alarm is to be provided with this equipment.
Warning: Owner's Instruction Notice (P/N: F01U265453): Not to be removed by anyone except occupant.

Bosch Security Systems, Inc. recommends testing the entire system at least once a week, and having a qualified technician check the system at a minimum of once every 3 years.

Minimum system requirements for Classification in accordance with ANSI/SIA CP-01-2010
UL Listed and Classified control unit Model B5512 or B4512;
UL Listed and Classified keypad Model B920 or B930;
UL Listed Local Bell

Suitable for the following applications: 1) Household Burglar Alarm System Units. 2) Household Fire Warning System Units. 3) Police Station connect, Mercantile Premise alarm system, Mercantile Safe and Vault alarm system. For all Police Station applications, Model D8108A Attack Resistant Enclosure with a UL Listed local sounding device is required. 4) Local, Mercantile Premise alarm system and Mercantile Safe and Vault alarm system. 5) Central Station, suitable as a dual signal line transmission system. 6) Proprietary Burg. 7) Holdup (UL) Alarm Units and System.

This equipment has been type tested and found to comply with the specifications in Part 15 of FCC rules for Class B Computing Devices. Operation is subject to the two following conditions (1) this device may not cause any interference, and (2) this device must accept any interference received including interference that may cause undesired operation.

Model number B430 complies with Part 68, FCC Rules. FCC Registration Number: ESVAL00BB430

Ringer Eq 0.0B

POWER SUPPLY REQUIREMENTS
The Power Supply provides a maximum of 800 mA for the Control Panel and all Accessory Devices.
All external connections are inherently power limited, Class 2.
Requirements for battery standby time might reduce allowable output.

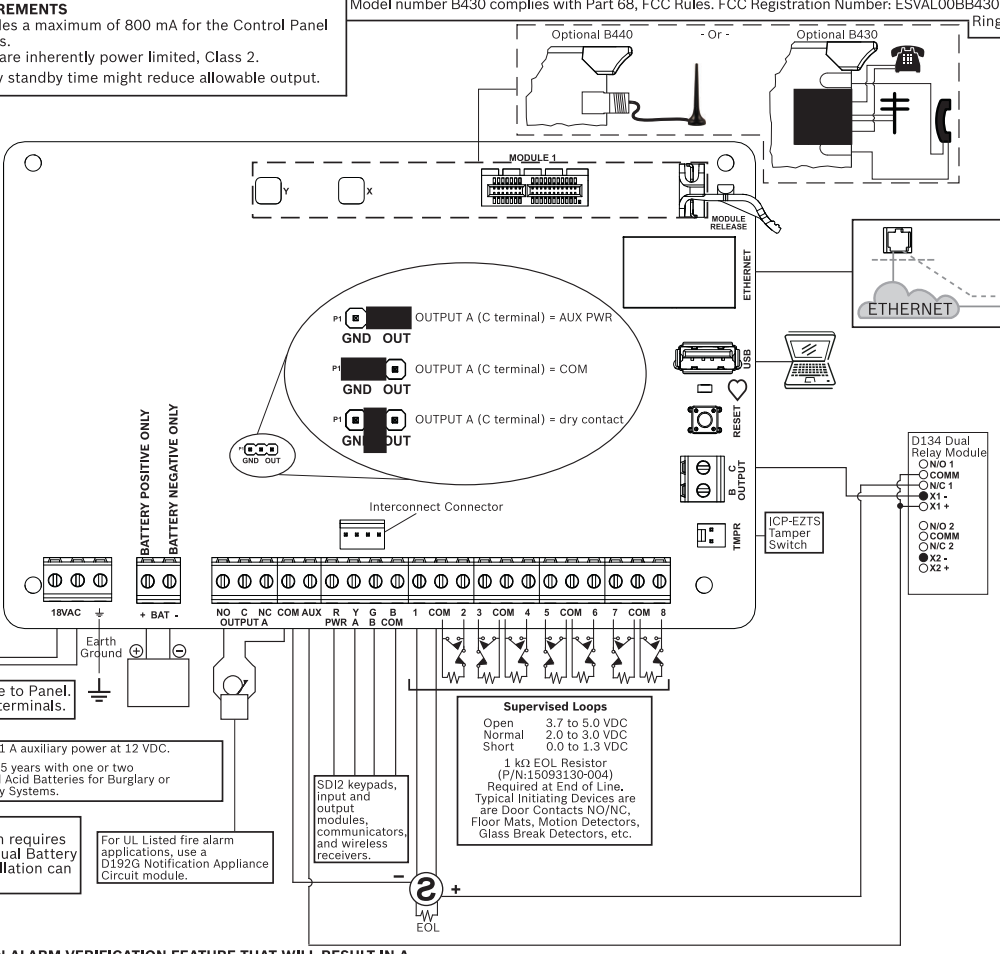

Supervised Loops

Open	3.7 to 5.0 VDC
Normal	2.0 to 3.0 VDC
Short	0.0 to 1.3 VDC

1 kΩ EOL Resistor (P/N:15093130-004)
Required at End of Line.
Typical Initiating Devices are
are Door Contacts NO/NC,
Floor Mats, Motion Detectors,
Glass Break Detectors, etc.

WARNING
THIS UNIT INCLUDES AN ALARM VERIFICATION FEATURE THAT WILL RESULT IN A DELAY OF THE SYSTEM ALARM SIGNAL FROM THE INDICATED CIRCUITS. THE TOTAL DELAY (CONTROL PANEL PLUS SMOKE DETECTORS) SHALL NOT EXCEED 60 SECONDS. NO OTHER SMOKE DETECTOR SHALL BE CONNECTED TO THESE CIRCUITS UNLESS APPROVED BY THE LOCAL AUTHORITY HAVING JURISDICTION.

Circuit (point)	Control panel delay, seconds	Smoke detector	
		Model	Delay, seconds*

* Include detector data or the following or equivalent statement: "Use the delay (power-up/start-up) time marked on the installation wiring diagram of the smoke detector or on the installed smoke detector(s)."

Auxiliary Powered Devices 11.5 to 12.4 VDC. Below 10.2 VDC, the B5512/B4512 stops processing Loop inputs.

This equipment should be installed in accordance with the CSA C22.1, Canadian Electrical Code, Part 1, Safety Standard for Electrical Installations.

B5512_B4512_ULLD-01

Communication:
Standard line security: Cellular or IP
A1: Cellular or IP
P1: DACT

F01U265442-03

8 Specifications

Control panel power supply specifications

Voltage Input (Power Supply)	Primary	18 VAC terminals	18 VAC 22 VA Class 2 transformer (CX4010)
	Secondary	BAT terminals	12 Volt Sealed Lead Acid Rechargeable Battery (D126 or D1218)
Current Requirements	Control Panel: Idle 125 mA; Alarm 155 mA Refer to the <i>Standby battery requirements and calculations</i> section in the <i>Control Panels (B5512/B4512) Installation and System Reference Guide</i> (P/N: F01U265444) for the current draw requirements of other system components.		
Power Outputs	All external connections are power-limited. The battery terminals are not power limited.		
	SDI2 terminals and interconnect connector	PWR/R and COM/B terminals	800 mA for continuously powered devices. Shared with AUX power terminal.
	Alarm power output	OUTPUT A terminal	1.3 A for Burglary applications. Output can be steady or one of four pulsed patterns depending on programming. Refer to <i>Outputs</i> in <i>RPS Help</i> or the <i>Control Panels (B5512/B4512) Program Entry Guide</i> (P/N: F01U265465).
	Aux power	AUX and COM terminals	800 mA for continuously powered devices. Shared with SDI2 R/PWR terminal and interconnect connector.
	Fire and Fire/Burglary Systems	Alarm power output for OUTPUT A cannot exceed 500 mA.	
Minimum Operating Voltage	10.2 VDC (The control panel might operate below this voltage, but it will cease to operate as an alarm panel.)		
SDI2 Bus	12 VDC nominal (7500 ft combined length) maximum		
Ethernet Connection	10BASE-T 100BASE-TX		
Battery Discharge/Recharge Schedule	Discharge cycle	13.65 VDC - Charging float level. 12.1 VDC - Low Battery Report, if programmed. 10.2 VDC - Minimum operational voltage.	
	Recharge Cycle	AC ON - Battery charging begins and AC Restoral Reports sent. 13.4 V - Battery Restoral Report sent. Battery float charged.	
Environmental	Temperature	0°C to +49°C (+32°F to 122°F)	
	Relative Humidity	5% to 93% at +32°C (+90°F) non-condensing	
Arming Stations	B920 Two-line Alphanumeric Keypads, B930 ATM Style Alphanumeric Keypads		

Point Thresholds	On-board points 1 to 8	Open - 3.7 to 5.0 VDC Normal - 2.0 to 3.0 VDC Short - 0.0 to 1.3 VDC Short circuit current - 5 mA
Compatible Enclosures	B10 Medium Control Panel Enclosure, B11 Small Control Panel Enclosure, D2203 Enclosure, D8103 Universal Enclosure, D8108A Attack Resistant Enclosure, and D8109 Fire Enclosure	

8.1 Wire requirements

Terminal label	Terminal description	Requirements
18VAC	AC	18 AWG min (up to 12 AWG max)
⊕	Earth ground	16 AWG min (up to 14 AWG max)
BAT +	Battery +	Bosch supplied wire lead, included with control panel.
BAT -	Battery -	Bosch supplied wire lead, included with control panel.
OUTPUT A NO	Output A normally open	22 AWG min (up to 12 AWG max)
OUTPUT A C	Output A common	
OUTPUT A NC	Output A normally closed	
COM	Common	
AUX	+ AUX power	
PWR/R	SDI2 power	22 AWG min (up to 12 AWG max)
A/Y	SDI2 data bus A	22 AWG min (up to 12 AWG max)
B/G	SDI2 data bus B	22 AWG min (up to 12 AWG max)
COM/B	SDI2 common	22 AWG min (up to 12 AWG max)
1	Point 1	22 AWG min (up to 12 AWG max)
COM	Point 1/2 common	
2	Point 2	
3	Point 3	
COM	Point 3/4 common	
4	Point 4	
5	Point 5	
COM	Point 5/6 common	
6	Point 6	
7	Point 7	
COM	Point 7/8 common	
8	Point 8	

OUTPUT B	Output B	22 AWG min (up to 12 AWG max)
OUTPUT C	Output C	

Bosch Security Systems, Inc.

130 Perinton Parkway

Fairport, NY 14450

USA

www.boschsecurity.com

© Bosch Security Systems, Inc., 2013