

MPF130, MPF131, MPF132 (SILICON) MFE130, MFE131, MFE132

N-CHANNEL DUAL-GATE SILICON-NITRIDE PASSIVATED MOS FIELD-EFFECT TRANSISTORS

... depletion mode (Type B) dual gate transistors designed for VHF amplifier and mixer applications. These types are specified as follows:

- MPF130/MFE130 – RF Amplifier @ 105 MHz
MPF131/MFE131 – RF Amplifier @ 60 and 200 MHz
MPF132/MFE132 – Mixer @ 60 and 200 MHz
- Silicon Nitride Passivation for Excellent Long Term Stability
- Diode Protected Gates
- Supplied in Metal Can or Plastic Packages –
MFE130 Series – TO-72
MPF130 Series – Case 262

MAXIMUM RATINGS

Rating	Symbol	Value	Unit	
Drain-Source Voltage	V_{DS}	25	Vdc	
Drain Current	I_D	30	mA _{dc}	
		MPF 130 Series	MFE130 Series	
Total Power Dissipation @ $T_A = 25^\circ\text{C}$ (Package Limitation) Derate above 25°C	P_D	350	300	mW
		2.33	1.71	mW/ $^\circ\text{C}$
Operating and Storage Channel Temperature Range	$T_{channel}$, T_{stg}	-65 to +175	-65 to +200	$^\circ\text{C}$

N-CHANNEL DUAL GATE MOS FIELD – EFFECT TRANSISTORS

MPF130
MPF131
MPF132

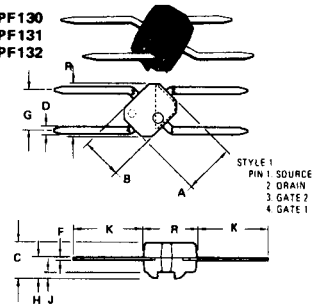

DIM	MILLIMETERS		INCHES	
	MIN	MAX	MIN	MAX
A	4.95	5.21	0.195	0.205
B	3.94	4.19	0.155	0.165
C	2.67	2.82	0.105	0.115
D	0.84	0.89	0.025	0.035
F	0.20	0.30	0.008	0.012
G	4.06 BSC		0.160 BSC	
H	1.57	1.83	0.062	0.072
J	0.51	0.76	0.020	0.030
K	8.35	7.62	0.250	0.300
R	5.21	5.46	0.205	0.215

CASE 262-02

MFE130
MFE131
MFE132

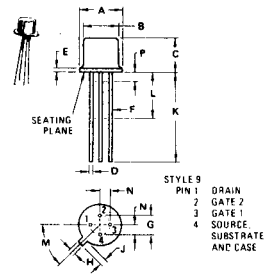

DIM	MILLIMETERS		INCHES	
	MIN	MAX	MIN	MAX
A	5.31	5.84	0.209	0.230
B	4.52	4.95	0.178	0.195
C	4.32	5.33	0.170	0.210
D	0.41	0.53	0.016	0.021
E		0.76		0.030
F	0.41	0.48	0.016	0.019
G	2.54 BSC		0.100 BSC	
H	0.91	1.17	0.035	0.046
J	0.71	1.22	0.028	0.048
K	12.70		0.500	
L	6.35		0.250	
M	4.94 BSC		0.194 BSC	
N	1.27 BSC		0.050 BSC	
P		1.27		0.050

CASE 20-03
TO-72

MPF130, MPF131, MPF132 (continued)
MFE130, MFE131, MFE132

ELECTRICAL CHARACTERISTICS ($T_A = 25^\circ\text{C}$ unless otherwise noted) Substrate Connected to Source

Characteristic	Symbol	Min	Typ	Max	Unit
OFF CHARACTERISTICS					
Drain-Source Breakdown Voltage ($I_D = 10 \mu\text{Adc}$, $V_S = 0$, $V_{G1} = -4.0 \text{ Vdc}$, $V_{G2} = +4.0 \text{ Vdc}$)	$V_{(BR)DSX}$	25	—	—	Vdc
Gate 1 – Source Breakdown Voltage ($I_{G1} = \pm 10 \mu\text{Adc}$, $V_{G2S} = 0$)	$V_{(BR)G1SO}$	± 7.0	—	± 20	Vdc
Gate 2 – Source Breakdown Voltage ($I_{G2} = \pm 10 \mu\text{Adc}$, $V_{G2S} = 0$)	$V_{(BR)G2SO}$	± 7.0	—	± 20	Vdc
Gate 1 to Source Cutoff Voltage ($V_{DS} = 15 \text{ Vdc}$, $V_{G2S} = 4.0 \text{ Vdc}$, $I_D = 200 \mu\text{Adc}$)	$V_{G1S(off)}$	—	—	-4.0	Vdc
Gate 2 to Source Cutoff Voltage ($V_{DS} = 15 \text{ Vdc}$, $V_{G1S} = 0$, $I_D = 200 \mu\text{Adc}$)	$V_{G2S(off)}$	—	—	-4.0	Vdc
Gate 1 Reverse Leakage Current ($V_{G1S} = \pm 6.0 \text{ Vdc}$, $V_{G2S} = 0$, $V_{DS} = 0$)	I_{G1SS}	—	—	20	nAdc
Gate 2 Reverse Leakage Current ($V_{G2S} = \pm 6.0 \text{ Vdc}$, $V_{G1S} = 0$, $V_{DS} = 0$)	I_{G2SS}	—	—	20	nAdc
ON CHARACTERISTICS					
Zero-Gate Voltage Drain Current ($V_{DS} = 15 \text{ Vdc}$, $V_{G1S} = 0$, $V_{G2S} = 4.0 \text{ Vdc}$)	I_{DSS}	3.0	10	30	mAdc
SMALL-SIGNAL CHARACTERISTICS					
Forward Transfer Admittance (Gate 1 connected to Drain) ($V_{DS} = 15 \text{ Vdc}$, $V_{G2S} = 4.0 \text{ Vdc}$, $I_D = 10 \text{ mAdc}$, $f = 1.0 \text{ kHz}$)	Y_{fs}	8000	—	20,000	μmhos
Input Capacitance ($V_{DS} = 15 \text{ Vdc}$, $V_{G2S} = 4.0 \text{ Vdc}$, $I_D = I_{DSS}$, $f = 1.0 \text{ MHz}$)	C_{iss}	—	4.5	7.0	pF
Output Capacitance ($V_{DS} = 15 \text{ Vdc}$, $V_{G2S} = 4.0 \text{ Vdc}$, $I_D = I_{DSS}$, $f = 1.0 \text{ MHz}$)	C_{oss}	—	2.5	4.0	pF
Reverse Transfer Capacitance ($V_{DS} = 15 \text{ Vdc}$, $V_{G2S} = 4.0 \text{ Vdc}$, $I_D = 6.0 \text{ mAdc}$, $f = 1.0 \text{ MHz}$)	C_{rss}	—	0.023	0.05	pF
Common-Source Noise Figure (Figure 7) ($V_{DS} = 15 \text{ Vdc}$, $V_{G2S} = 4.0 \text{ Vdc}$, $I_D = 6.0 \text{ mAdc}$, Z_S is optimized for NF)	NF				dB
($f = 105 \text{ MHz}$)	MPF/MFE130	—	2.9	5.0	
($f = 60 \text{ MHz}$)	MPF/MFE131	—	2.5	5.0	
($f = 200 \text{ MHz}$)	MPF/MFE131	—	3.0	5.0	
Common-Source Power Gain (Figure 7) ($V_{DS} = 15 \text{ Vdc}$, $V_{G2S} = 4.0 \text{ Vdc}$, $I_D = 6.0 \text{ mAdc}$, Z_S is optimized for NF)	G_{ps}				dB
($f = 105 \text{ MHz}$)	MPF/MFE130	17	23	—	
($f = 60 \text{ MHz}$)	MPF/MFE131	20	27	—	
($f = 200 \text{ MHz}$)	MPF/MFE131	17	20	—	
Level of Unwanted Signal for 1.0% Cross Modulation ($V_{DS} = 15 \text{ Vdc}$, $V_{G2S} = 4.0 \text{ Vdc}$, $I_D = 6.0 \text{ mAdc}$)	—	—	100	—	mV
Common-Source Conversion Power Gain (Gate 1 Injection, Figure 8). ($V_{DS} = 15 \text{ Vdc}$, $V_{G2S} = 4.0 \text{ Vdc}$, Local Oscillator Voltage = 925 mVrms)	G_c				dB
(Signal Frequency = 60 MHz, Local Oscillator Frequency = 104 MHz)	MPF/MFE132	15	16.5	—	
(Signal Frequency = 200 MHz, Local Oscillator Frequency = 244 MHz)	MPF/MFE132	12	14	—	

MPF130, MPF131, MPF132 (continued)
MFE130, MFE131, MFE132

COMMON-SOURCE ADMITTANCE PARAMETERS

($V_{DS} = 15$ Vdc, $V_{G2S} = 4.0$ Vdc, $I_D = 6.0$ mAdc)

FIGURE 1 – INPUT ADMITTANCE

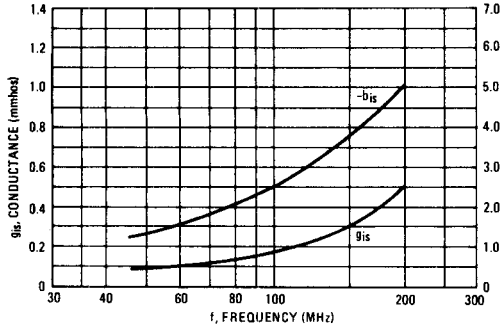

FIGURE 2 – REVERSE TRANSFER ADMITTANCE

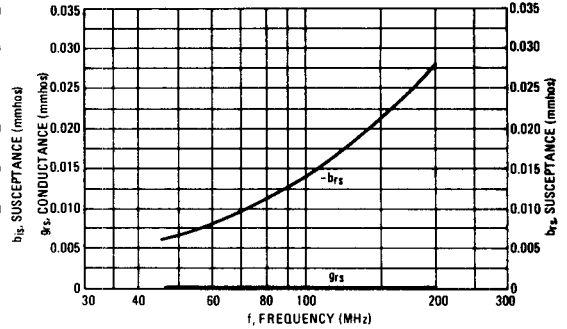

FIGURE 3 – FORWARD TRANSFER ADMITTANCE

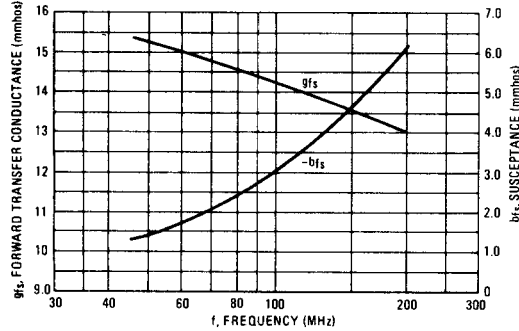

FIGURE 4 – OUTPUT ADMITTANCE

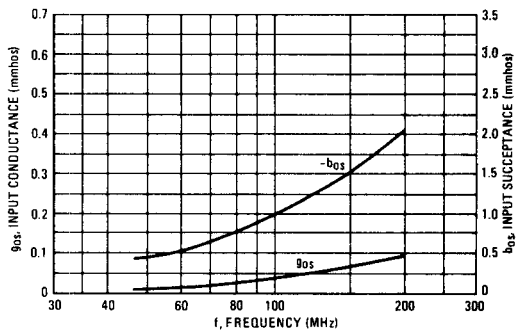

FIGURE 5 – GAIN REDUCTION

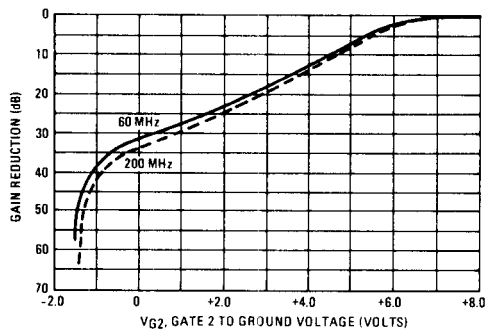
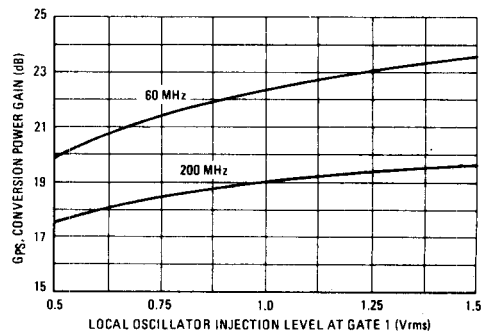
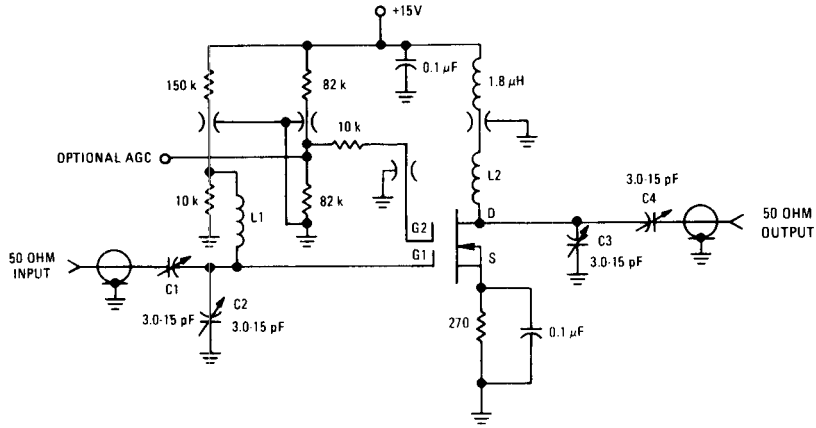

FIGURE 6 – CONVERSION POWER GAIN



MPF130, MPF131, MPF132 (continued)
MFE130, MFE131, MFE132

FIGURE 7 — 60, 105 AND 200 MHz POWER GAIN AND NOISE FIGURE TEST CIRCUIT



	L1	L2
60 MHz	0.33 μH	0.47 μH
105 MHz	#16 AWG, 6 1/2 Turns, 1" Long, 1/4" Dia.	=16 AWG, 5 1/4 Turns, 1" Long, 7/16" Dia.
200 MHz	#16 AWG, 3 1/2 Turns, 0.7" Long, 0.2" Dia.	=16 AWG, 4 1/2 Turns, 0.65" Long, 0.2" Dia.

All Feedthrough Capacitors 1000 pF

All Variable Capacitors JOHANSON JMC2951, 3.0-15 pF

FIGURE 8 — 60 AND 200 MHz CONVERSION GAIN TEST CIRCUIT

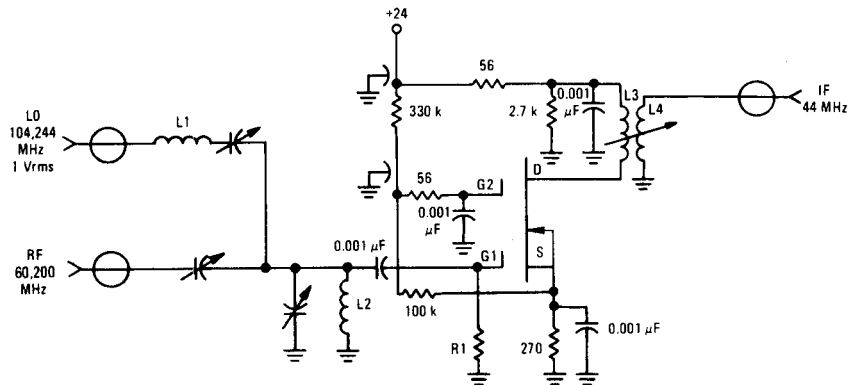

	R1	L1	L2	L3	L4
60 MHz	10 k	10 Turns #22 Enameled on MILLER 4500-4 Core.	0.33 μH DELEVAN	15 Turns #26 Enameled on MILLER 4500-1 Core	4 Turns #26 Enameled on Same Core as L3
200 MHz	1.0 k	3 1/2 Turns #18, 1/4" Dia., 1/2" Long	2 1/2 Turns #18, 3/8" Dia., 1/2" Long	15 Turns #26 Enameled on MILLER 4500-1 Core	4 Turns #26 Enameled on Same Core as L3

All Feedthrough Capacitors 1000 pF.

All Variable Capacitors JOHANSON JMC2951, 3.0-15 pF