



Walk-Through Metal Detector

User Manual

# Legal Information

## About this Manual

The Manual includes instructions for using and managing the Product. Pictures, charts, images and all other information hereinafter are for description and explanation only. The information contained in the Manual is subject to change, without notice, due to firmware updates or other reasons. Please find the latest version of this Manual at the Hikvision website (<https://www.hikvision.com/>).

Please use this Manual with the guidance and assistance of professionals trained in supporting the Product.

## Trademarks

**HIKVISION** and other Hikvision's trademarks and logos are the properties of Hikvision in various jurisdictions.

Other trademarks and logos mentioned are the properties of their respective owners.

## Disclaimer

TO THE MAXIMUM EXTENT PERMITTED BY APPLICABLE LAW, THIS MANUAL AND THE PRODUCT DESCRIBED, WITH ITS HARDWARE, SOFTWARE AND FIRMWARE, ARE PROVIDED "AS IS" AND "WITH ALL FAULTS AND ERRORS". HIKVISION MAKES NO WARRANTIES, EXPRESS OR IMPLIED, INCLUDING WITHOUT LIMITATION, MERCHANTABILITY, SATISFACTORY QUALITY, OR FITNESS FOR A PARTICULAR PURPOSE. THE USE OF THE PRODUCT BY YOU IS AT YOUR OWN RISK. IN NO EVENT WILL HIKVISION BE LIABLE TO YOU FOR ANY SPECIAL, CONSEQUENTIAL, INCIDENTAL, OR INDIRECT DAMAGES, INCLUDING, AMONG OTHERS, DAMAGES FOR LOSS OF BUSINESS PROFITS, BUSINESS INTERRUPTION, OR LOSS OF DATA, CORRUPTION OF SYSTEMS, OR LOSS OF DOCUMENTATION, WHETHER BASED ON BREACH OF CONTRACT, TORT (INCLUDING NEGLIGENCE), PRODUCT LIABILITY, OR OTHERWISE, IN CONNECTION WITH THE USE OF THE PRODUCT, EVEN IF HIKVISION HAS BEEN ADVISED OF THE POSSIBILITY OF SUCH DAMAGES OR LOSS.

YOU ACKNOWLEDGE THAT THE NATURE OF INTERNET PROVIDES FOR INHERENT SECURITY RISKS, AND HIKVISION SHALL NOT TAKE ANY RESPONSIBILITIES FOR ABNORMAL OPERATION, PRIVACY LEAKAGE OR OTHER DAMAGES RESULTING FROM CYBER-ATTACK, HACKER ATTACK, VIRUS INSPECTION, OR OTHER INTERNET SECURITY RISKS; HOWEVER, HIKVISION WILL PROVIDE TIMELY TECHNICAL SUPPORT IF REQUIRED.

YOU AGREE TO USE THIS PRODUCT IN COMPLIANCE WITH ALL APPLICABLE LAWS, AND YOU ARE SOLELY RESPONSIBLE FOR ENSURING THAT YOUR USE CONFORMS TO THE APPLICABLE LAW. ESPECIALLY, YOU ARE RESPONSIBLE, FOR USING THIS PRODUCT IN A MANNER THAT DOES NOT INFRINGE ON THE RIGHTS OF THIRD PARTIES, INCLUDING WITHOUT LIMITATION, RIGHTS OF PUBLICITY, INTELLECTUAL PROPERTY RIGHTS, OR DATA PROTECTION AND OTHER PRIVACY RIGHTS. YOU SHALL NOT USE THIS PRODUCT FOR ANY PROHIBITED END-USES, INCLUDING THE DEVELOPMENT OR PRODUCTION OF WEAPONS OF MASS DESTRUCTION, THE DEVELOPMENT OR PRODUCTION OF CHEMICAL OR BIOLOGICAL WEAPONS, ANY ACTIVITIES IN THE CONTEXT RELATED TO ANY NUCLEAR EXPLOSIVE OR UNSAFE NUCLEAR FUEL-CYCLE, OR IN SUPPORT OF HUMAN RIGHTS ABUSES.

IN THE EVENT OF ANY CONFLICTS BETWEEN THIS MANUAL AND THE APPLICABLE LAW, THE LATER PREVAILS.

### EU Conformity Statement



This product and - if applicable - the supplied accessories too are marked with "CE" and comply therefore with the applicable harmonized European standards listed under the EMC Directive 2014/30/EU, the LVD Directive 2014/35/EU, the RoHS Directive 2011/65/EU.



2012/19/EU (WEEE directive): Products marked with this symbol cannot be disposed of as unsorted municipal waste in the European Union. For proper recycling, return this product to your local supplier upon the purchase of equivalent new equipment, or dispose of it at designated collection points. For more information see: [www.recyclethis.info](http://www.recyclethis.info)



2006/66/EC (battery directive): This product contains a battery that cannot be disposed of as unsorted municipal waste in the European Union. See the product documentation for specific battery information. The battery is marked with this symbol, which may include lettering to indicate cadmium (Cd), lead (Pb), or mercury (Hg). For proper recycling, return the battery to your supplier or to a designated collection point. For more information see: [www.recyclethis.info](http://www.recyclethis.info)

### BATTERY WARNING

1. Do not ingest battery, Chemical Burn Hazard
2. Keep new and used batteries away from the children.
3. If the battery compartment does not close securely, stop using the product and keep it away from children.
4. This product contains a coin / button cell battery. If the coin / button cell battery is swallowed, it can cause severe internal burns in just 2 hours and lead to death.
5. If you think batteries might have been swallowed or placed inside any part of the body, seek immediate medical attention.

### BATTERY CAUTION



1. Risk of fire or explosion if the battery is replaced by an incorrect type.
2. Improper replacement of the battery with an incorrect type may defeat a safeguard (for example, in the case of some lithium battery types).
3. Do not dispose of the battery into fire or a hot oven, or mechanically crush or cut the battery, which may result in an explosion.
4. Do not leave the battery in an extremely high temperature surrounding environment, which may result in an explosion or the leakage of flammable liquid or gas.
5. Do not subject the battery to extremely low air pressure, which may result in an explosion or the leakage of flammable liquid or gas.
6. Dispose of used batteries according to the instructions
7. The equipment is not suitable for use in locations where children are likely to be present.

### INSTALLATION CAUTION

1. The additional force shall be equal to three times the weight of the equipment but not less than 50N. The equipment and its associated mounting means shall remain secure during the installation. After the installation, the equipment, including any associated mounting plate, shall not be damaged.
2. This equipment is not suitable for use in locations where children are likely to be present.

# Symbol Conventions

The symbols that may be found in this document are defined as follows.

Symbol	Description
 <b>Danger</b>	Indicates a hazardous situation which, if not avoided, will or could result in death or serious injury.
 <b>Caution</b>	Indicates a potentially hazardous situation which, if not avoided, could result in equipment damage, data loss, performance degradation, or unexpected results.
 <b>Note</b>	Provides additional information to emphasize or supplement important points of the main text.

# Safety Instruction

These instructions are intended to ensure that user can use the product correctly to avoid danger or property loss. If the device is not used according to the method specified by the manufacturer, the protection provided by the device may be damaged.

## Laws and Regulations

- Use of the product must be in strict compliance with the local electrical safety regulations.

## Transportation

- Keep the device in original or similar packaging while transporting it.
- Keep all wrappers after unpacking them for future use. In case of any failure occurred, you need to return the device to the factory with the original wrapper. Transportation without the original wrapper may result in damage on the device and the company shall not take any responsibilities.
- Do not drop the product or subject it to physical shock. Keep the device away from magnetic interference.

## Power Supply

- Input voltage should meet the Limited Power Source according to the IEC61010-1 standard. Please refer to technical specifications for detailed information.
- Make sure the plug is properly connected to the power socket.
- DO NOT connect multiple devices to one power adapter, to avoid over-heating or fire hazards caused by overload.

## Battery

- Improper use or replacement of the battery may result in explosion hazard. Replace with the same or equivalent type only. Dispose of used batteries in conformance with the instructions provided by the battery manufacturer.
- The built-in battery cannot be dismantled. Please contact the manufacture for repair if necessary.
- For long-term storage of the battery, make sure it is fully charged every half year to ensure the battery quality. Otherwise, damage may occur.

## Maintenance

- If the product does not work properly, please contact your dealer or the nearest service center. We shall not assume any responsibility for problems caused by unauthorized repair or maintenance.
- A few device components (e.g., electrolytic capacitor) require regular replacement. The average lifespan varies, so periodic checking is recommended. Contact your dealer for details.
- Wipe the surface of device gently with a clean cloth and a small quantity of ethanol regularly.
- If the equipment is used in a manner not specified by the manufacturer, the protection provided by the device may be impaired.

## Using Environment

- Make sure the running environment meets the requirement of the device. The operating temperature shall be -20°C to 55°C, and the operating humidity shall be 10%-95%, no condensing.
- DO NOT expose the device to high electromagnetic radiation or dusty environments.
- DO NOT aim the lens at the sun or any other bright light.
- Do not place the device in a position where it is difficult to operate the disconnection device.

## **Emergency**

- If smoke, odor, or noise arises from the device, immediately turn off the power, unplug the power cable, and contact the service center.

## **Manufacture Address**

No.555 Qianmo Road, Binjiang District, Hangzhou 310052, China  
Hangzhou Hikvision Digital Technology Co.,Ltd

# Contents

<b>Chapter 1 Overview</b> .....	<b>8</b>
1.1 Product Description .....	8
1.2 Key Features .....	8
<b>Chapter 2 Installation</b> .....	<b>10</b>
2.1 Installation Environment .....	10
2.1.1 Fixed Metal Object .....	10
2.1.2 Ground Vibration.....	10
2.1.3 Moving Metal Object .....	10
2.1.4 Radiated Electronic Interference .....	11
2.1.5 Conducting Electronic Interference .....	11
2.2 Multiple Device Working Side by Side .....	12
2.3 Before Working Device Setting .....	12
2.4 Installation and Wiring .....	12
<b>Chapter 3 Local Configuration</b> .....	<b>15</b>
3.1 Function Description .....	15
3.2 Control Panel Settings .....	15
3.3 Remote Control Instruction.....	16
3.4 Activation Instructions .....	16
<b>Chapter 4 Network Settings</b> .....	<b>18</b>
<b>Appendix</b> .....	<b>19</b>
FAQ.....	19
Common Material Emissivity Reference .....	20
Detection Sensitivity for Guns.....	21
Dimension .....	23
Detection Program .....	24
Specification .....	25

# Chapter 1 Overview

## 1.1 Product Description



This smart security door is a walk-through metal detector which has high sensitivity and strong anti-interference ability. It can detect metals from people who pass through the gate, which can effectively check illegal items. It supports networking functions to meet the platform management needs in different scenarios. It can be used in public security organs, prisons, governments, transportation hubs, enterprise parks, office buildings, schools, hospitals, cultural and expo scenic spots, large-scale security activities, etc.

## 1.2 Key Features

- Metal detection: clip-sized metal can be detected, effectively checking illegal items;
- Networking function: the device can connect to a single machine, and parameters can be configured via web client;
- Display: 7-inch LCD display shows the number of people who passed through, number of metal alarm and other information; rear 29-inch screen displays video, face capture, location display, alarm information, etc. It can be switched to the information release screen to achieve flexible playback of different materials such as pictures, audio, video, subtitles, and real-time pictures;
- Remote Control: supports parameter configuration with IR remote control;

- Multi-zone alarm function: when multiple metals in different positions of the human body pass through the security gate, they will trigger alarm at the same time, and positions of multiple metals can be indicated(up to 33 zones);
- Casting Metal Alarm: alarm triggered when metal objects are casted through the door;
- Ultra-low detection height: metal objects more than 3 cm above the ground will trigger alarm when they enter the detection area;
- Power-on self-test function: self test the system when power on, and test results will be displayed;
- Capture: configure 2 million starlight IPC to achieve all-day video and picture recording and backchecking;
- Modular component design: convenient and quick to transport and maintain.

# Chapter 2 Installation

## 2.1 Installation Environment

In order to ensure the optimal operation of the detector and the maximum flow of people, the following important factors are taken into account to minimize the impacts made by different interference sources.

### 2.1.1 Fixed Metal Object

Large fixed or immovable metal objects should be at least 1m (40in) away from the detector (to detect large metal objects). This has less impact on the sensitivity, but may make the detector more susceptible to vibration.



### 2.1.2 Ground Vibration

The ground should be flat, with strong support, to prevent vibration, especially when there are vibration metal structures under the ground.

### 2.1.3 Moving Metal Object

The large metal objects moving outside the detector shall be kept at least at a distance of 0.5-2m (20-79in) from the detector to avoid false alarm. According to the size of the metal object, the distance between the required moving metal object and the detector may differ.

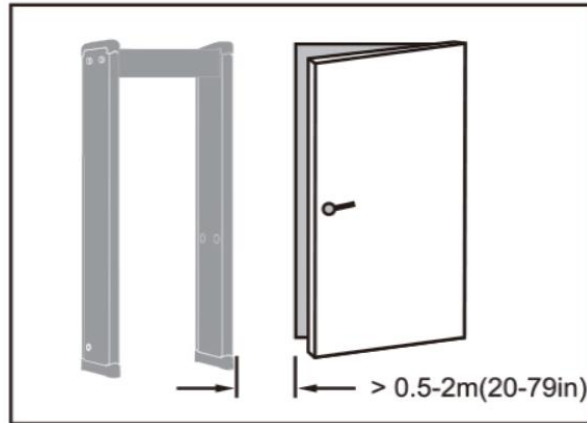

### 2.1.4 Radiated Electronic Interference

The distance between the electronic interference source and the receiving coil should be maximum. The recommended minimum distance is 0.5-4m (20-157in). However, the actual distance should vary according to the specific situation.

The interference may be caused by electronic control panel, radio equipment and computer, image display, high-power motor and transformer, AC wire, transistor control circuit, flash fluorescent lamp, ARC welding equipment, etc.

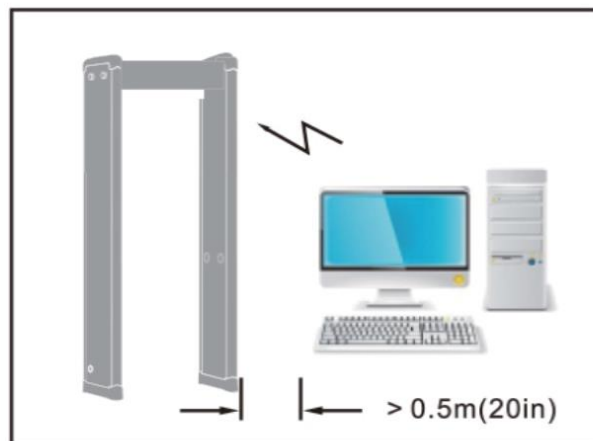

### 2.1.5 Conducting Electronic Interference

Connecting the power cable to a circuit that is not connected with other large load equipment may cause voltage shock.

The recommended min. distance away from the interference source:

- A. With fixed metal object
- B. No moving metal object is allowed
- C. No electronic interference source is allowed

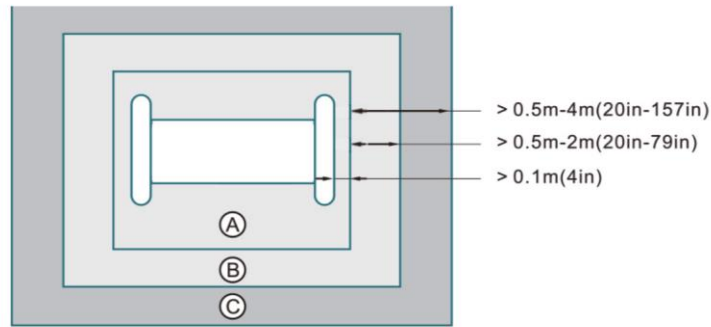

Note: Make the Receiving Coil (RX) away from the interference source. Make sure the interference level displayed on the environment inspection indicator is less than 2.

## 2.2 Multiple Device Working Side by Side

Side-by-side operation refers to the operation of two or more detectors in close proximity to each other. With side-by-side operation, the detector may interfere with each other. The level of interference depends on the distance between the detectors and their operating frequency and sensitivity.

The detector has different working frequency selection, which can decrease the effect of interference of other gates. The operating frequency of each detector should be different.

## 2.3 Before Working Device Setting

Select the smallest metal item to be detected. Choose one person to carry the item and pass through the security gate (Make sure the person doesn't take any other extra metal items). Adjust the alarm threshold to meet the detection requirements. (Note: the factory detection standard is one-yuan coin passing horizontally, and the detection alarm triggered.)

## 2.4 Installation and Wiring

1. Check if the package is completed and then open the package box.

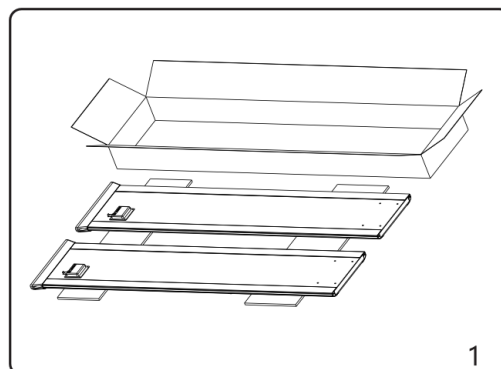

2. Take out the device and accessories.

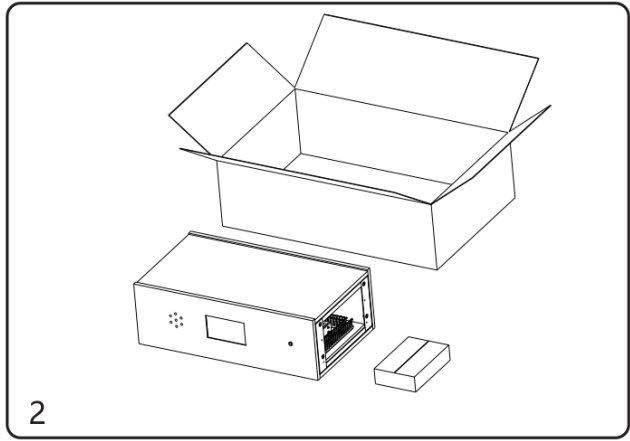

3. Connect the power plug, aviation plug and cable plug.

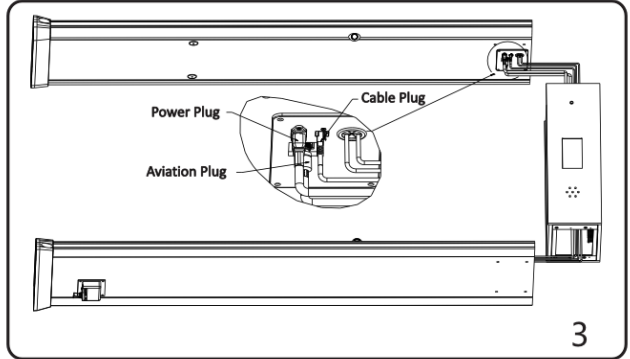

4. Install the door planks, screws, main control panel and top cover. Tighten the screws to fix all the components.

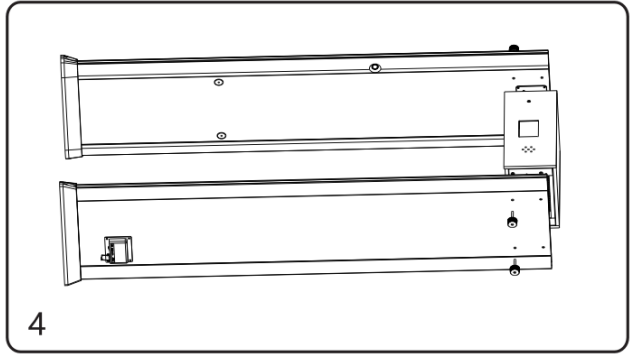

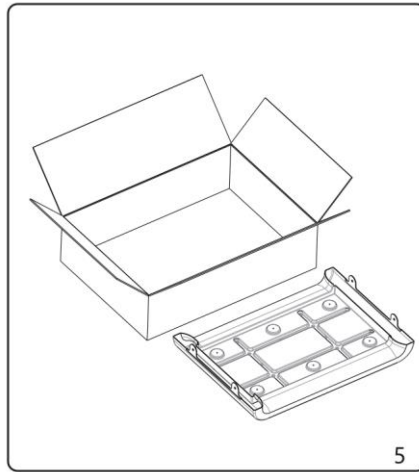

5. Connect the power supply to the device and turn on the power switch to start the device.

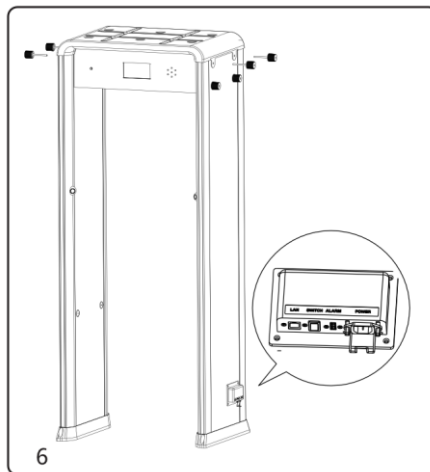

# Chapter 3 Local Configuration

## 3.1 Function Description

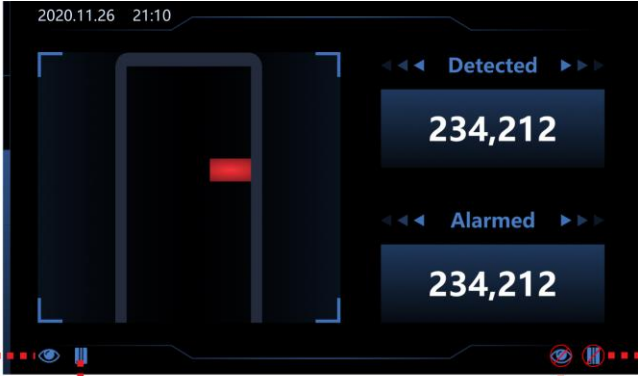

2020.11.26 21:10

Detected  
234,212

Alarmed  
234,212

- The infraed is connected.
- The detection cable is connected.
- The infraed is not connected.
- The detection cable is not connected.

Display connection status of left detection cable.

Display connection status of the previous group.

Display connection status of right detection cable.

Display connection status of the rear group.



Category  
CONTRABAND

Location  
HEAD

Time  
10:19:20

BJT  
10:23:20

Detected  
224

Alarmed  
12

HIKVISION

Contraband Position

## 3.2 Control Panel Settings

### Starting up

Connect the power supply and press the power button. The device will start and enter the system self-test program. At the same time, the column lights in each area will be on at this time.

### Input Password

When using the security gate for the first time, customers need to activate the device and set the password by

themselves.

### Equipment Self-test

The current infrared and door status will be displayed on the left and right corners of the device UI. If the fault occurs, the corresponding position will display an icon like .

## 3.3 Remote Control Instruction



Power Button: Power on or off the machine



Home button: Return to home page



Debugging Button: Enter the page of debugging configuration



Menu Button: Enter the menu page



Return Button: Return to the previous menu or cancel the setting



Direction Button: Switch options or modify parameters

Confirm Button: Enter next menu or confirm settings

Note: Reserved function, realized after the gate is upgraded



Volume -



Volume +



Mute Button



## 3.4 Activation Instructions

After powering on, you need to activate the device. You can activate the device via SADP tool or web client.

### Activate Device via SADP Tool

1. Connect the device and the PC with a network cable.
2. Install and run the SADP tool.
3. Check the device status from the device list, and select an inactive device.
4. Create a password in the password field, and confirm the password.
5. Set network parameters.

### Activate Device via Web Client

1. Connect the device and the PC with a network cable.
2. Enter the device IP address in the web browser.
3. Enter the account of admin and create a password in the pop-up window.

We highly recommend you create a strong password of your own choosing (using 8-16 characters, including at

least two kinds of following categories: upper case letters, lower case letters, numbers, and special characters) in order to increase the security of your product. We also recommend you reset your password regularly, especially in the high security system, resetting the password monthly or weekly can better protect your product.

# Chapter 4 Network Settings

After the power is on and the device is connected to the network, enter the IP address, activate the device and enter the page of network settings.

1	<b>Alarm threshold:</b> the lower the value, the higher the ability of metal detection.
2	<b>Filter Large Metal:</b> select Enable the large metal filtering function and set the threshold.
3	<b>Quick scene:</b> after enabling, the gate will set sensitivity based on quick scenario system.
4	<b>Working frequency:</b> set the working frequency of the coil. When there are multiple devices working side by side, make sure the frequency between each gate is different.
5	<b>Casting Metal Mode:</b> configure whether to enable casting metal detection, which is to link with infrared for metal detection.
6	<b>Detection area:</b> set the detection area of the gate.
7	<b>Alarm volume:</b> set the volume of the alarm.
8	<b>Alarm tone:</b> set the sound effect of the alarm.
9	<b>Alarm duration:</b> set the length of the alarm.
10	<b>Pass direction:</b> set the pass direction of the gate. The side without LCD screen will be taken as the forward direction by default.
11	<b>Intrusion alarm:</b> configure whether to enable intrusion alarm. After enabling, if the metal enters the gate before the detection process is finished, the intrusion alarm will be triggered.
12	<b>Random alarm:</b> configure whether to enable random alarm. After enabling, if there is no alarm after multiple people passing, a random alarm will be triggered when next person passes.
13	<b>Alarm output:</b> configure metal alarm linking alarm output, which can be linked with peripheral devices such as turnstile.

# Appendix

## FAQ

No.	Symptom	Description	Possible Reason	Solution	Tool
1	Unable to Boot	The device cannot be normally started after installation	<ol style="list-style-type: none"> <li>1. Check whether the power button is on and whether the button indicator light is on.</li> <li>2. Check whether the power cord is damaged, broken, bad contact, etc., and whether the power supply of the main chassis is normal.</li> </ol>	<ol style="list-style-type: none"> <li>1. Replace digital board</li> <li>2. Check power supply circuit</li> </ol>	Manual operation
2	Screen off	The LCD screen is off	Check whether the power button is on and whether the connecting wire of the connecting panel of the main board is properly plugged.	Replace cable, display, and digital board.	Manual operation
3	No people counting	The number of people displayed as 0001 or 0000.	Repeatedly pass through, and the number of people passing through does not change.	Replace the infrared component	Manual operation
4	False Alarm	The alarm is triggered when there is no people walk through	<ol style="list-style-type: none"> <li>1. Check whether the environment around the detector affects. Change the frequency.</li> <li>2. Whether the number of people passed automatically changed.</li> <li>3. Adjust the alarm threshold</li> <li>4. Check whether there is any large metal within 1 m nearby. If there is, please stay away.</li> </ol>	<ol style="list-style-type: none"> <li>1. Replace the infrared component</li> <li>2. Adjust the sensitivity value</li> </ol>	Manual operation
5	Omitting alarm	No alarm when walk through the detector with metal	<ol style="list-style-type: none"> <li>1. Adjust the alarm threshold</li> <li>2. Check whether there is any large metal within 1 m nearby. If there is, please stay away.</li> </ol>	Adjust the alarm threshold	Manual operation

## Common Material Emissivity Reference

<b>Material</b>	<b>Emissivity</b>
Human Skin	0.98
Printed Curcuit Board	0.91
Concrete	0.95
Ceramic	0.92
Rubber	0.95
Paint	0.93
Wood	0.85
Pitch	0.96
Brick	0.95
Sand	0.90
Soil	0.92
Cloth	0.98
Hard Paperboard	0.90
White Paper	0.90
Water	0.96

# Detection Sensitivity for Guns

The smaller the histogram, the lower the sensitivity level required.

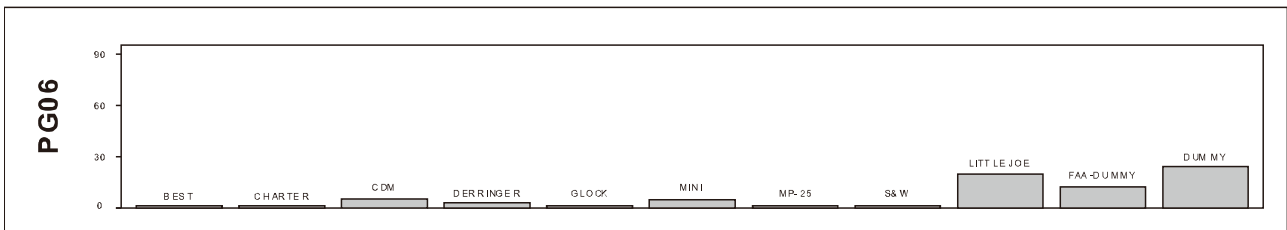
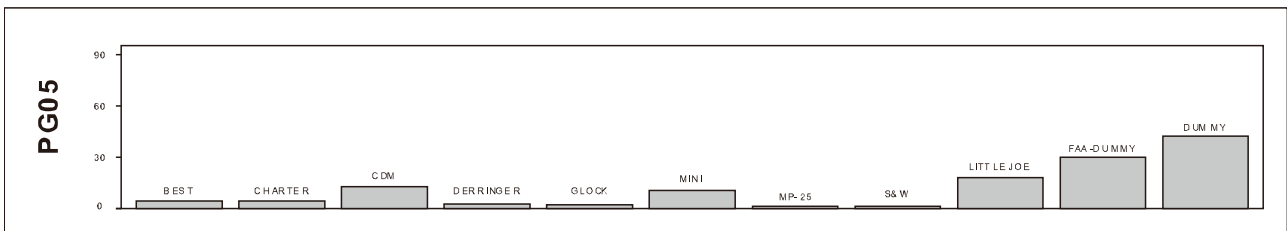
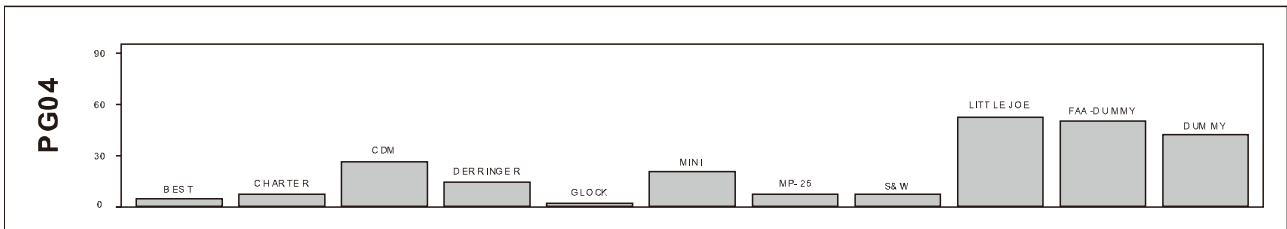
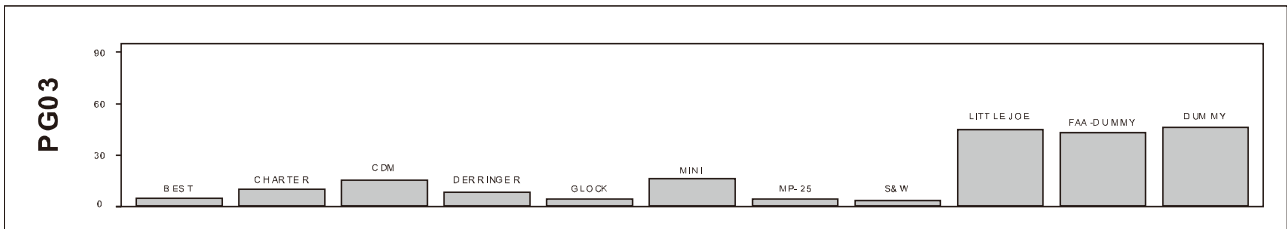
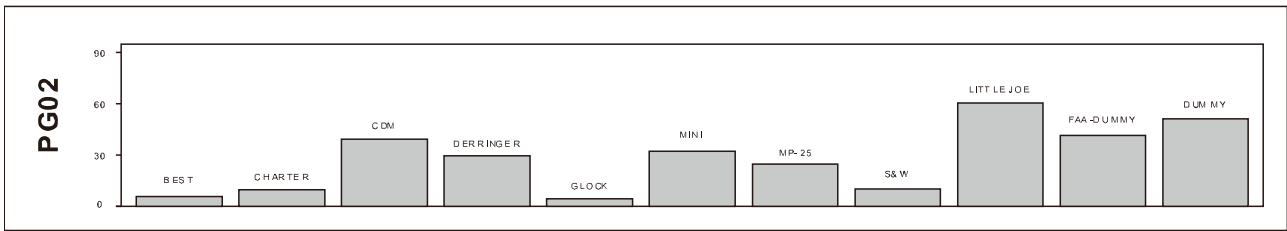
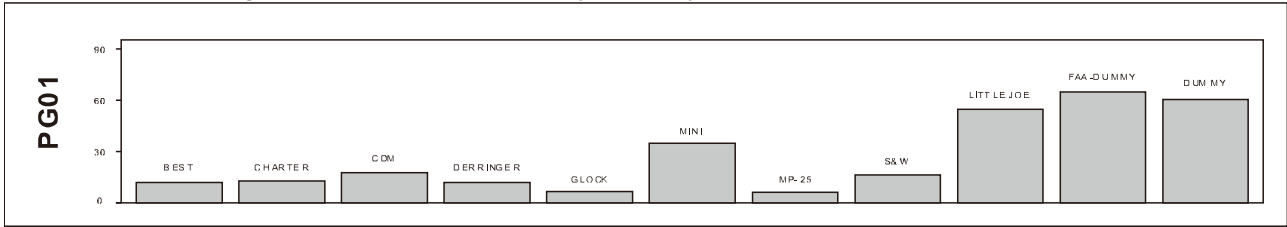

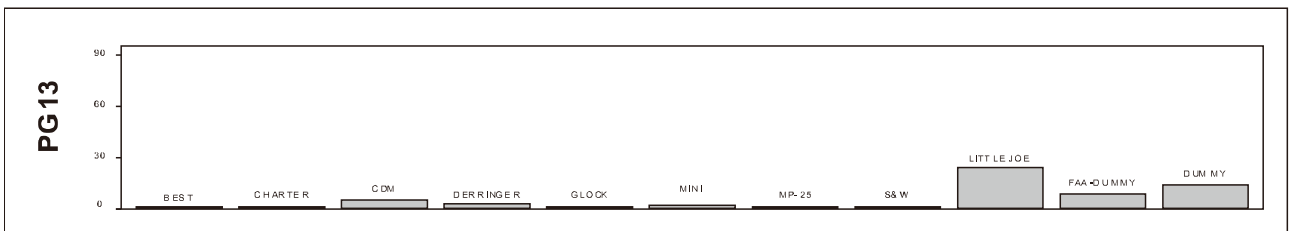
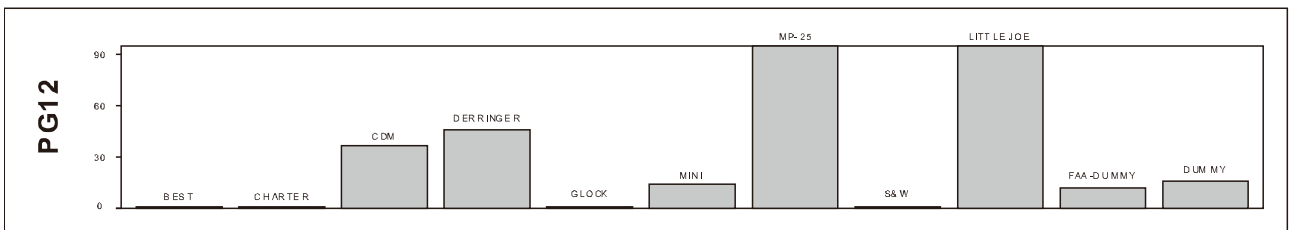
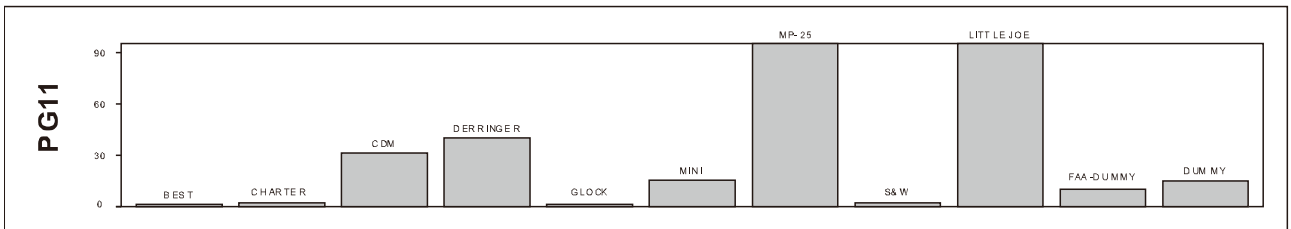
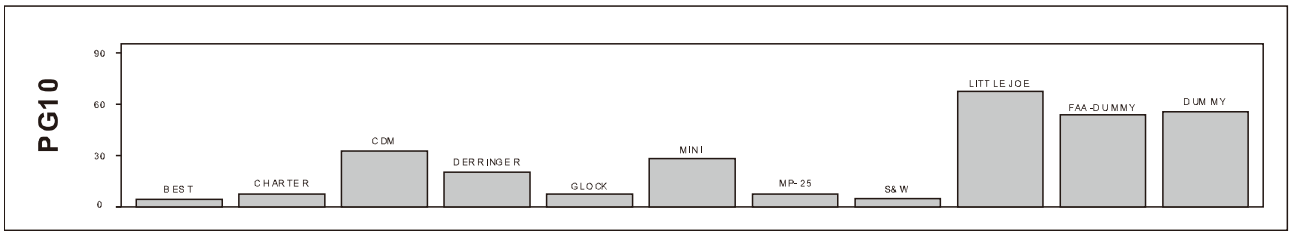
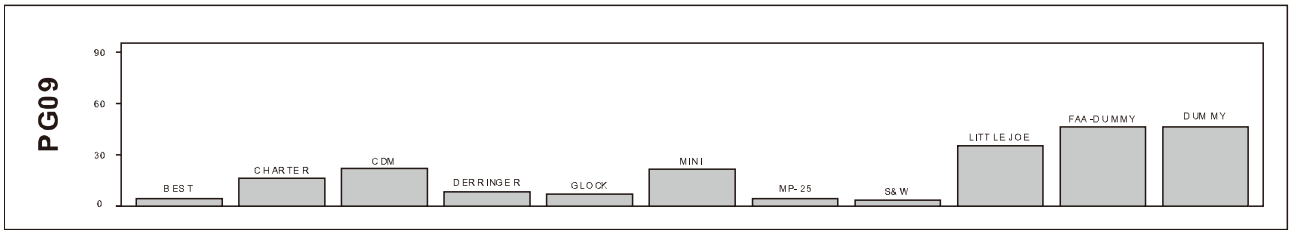
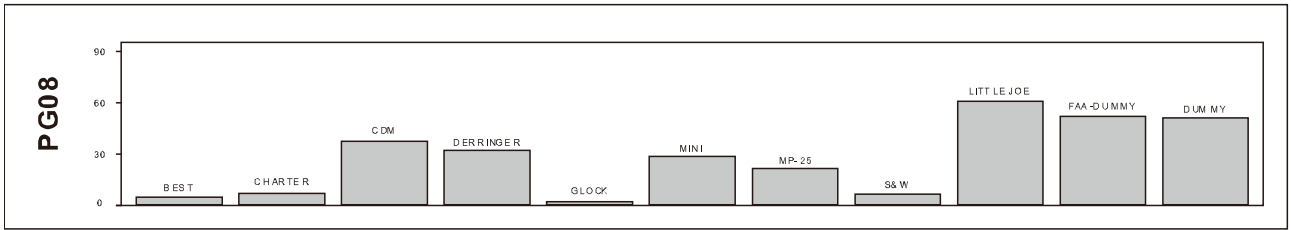
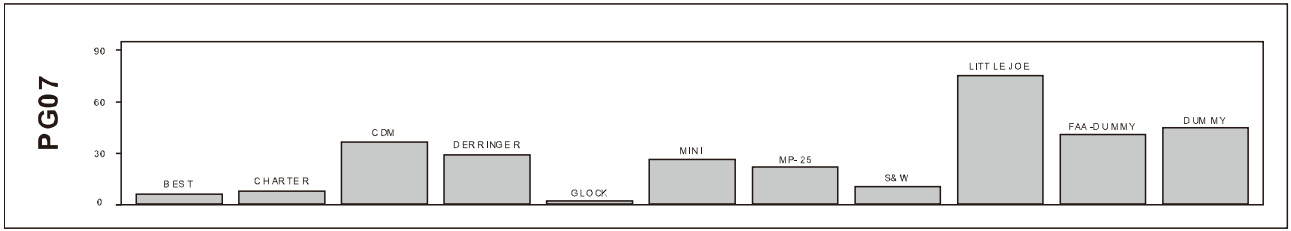

# Dimension

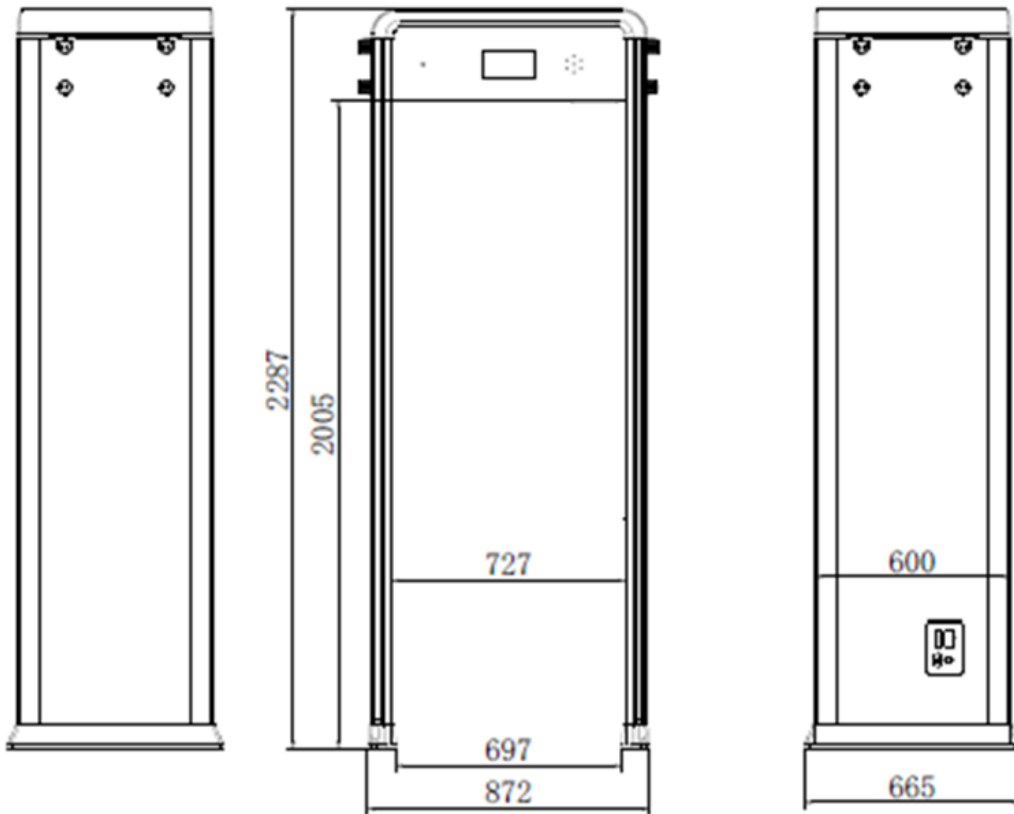

## Detection Program

Detection Program	Description	Performance		Distinguishability	
		High Pass	Optimizing Detection	High	Low
PRG 01 USA PRG 02 USA HD	U.S. airport security requirements	x	x	x	x
PRG 03 CAN PRG 04 CAN HD	Canadian airport security requirements	x	x	x	x
PRG 05 GER PRG 06 GER HD	German airport security requirements	x	x	x	x
PRG 07 UK PRG 08 UK HD	The UK airport security requirements	x	x	x	x
PRG 09 USG PRG 10 USG HD	U.S. government security requirements	x	x	x	x
PRG 11 SCA PRG 12 SCA HD	Scandinavian airport security requirements	x	x	x	x
Material Sensitivity Program					
PRG 13 STANDARD	General detection program				
PRG 21 PB-LEAD	Sensitivity to lead (as opposed to iron)				
PRG 22 MU-METAL	Maximum sensitivity for mu-metal				
PRG 23 ALLMETAL	High sensitivity to all metals				
PRG 24 FE >>>> AL	The procedures from 24 to 32 are compared with 40 mm iron and aluminum tubes.				
PRG 25 FE >>> AL					
PRG 26 FE >> AL					
PRG 27 FE > AL					
PRG 28 FE = AL					
PRG 29 FE < AL					
PRG 30 FE << AL					
PRG 31 FE <<< AL					
PRG 32 FE <<<< AL					

## Specification

General	Power supply	AC 100 V~240 V
	Consumption	< 35 W
	Operation temperature and humidity	-20°C to 55°C, ≤ 95%, RH
	Testing object	Illegal items, including smart phones and metals
	Current frequency	50 Hz~60 Hz
Dimension	Detector dimension	2287 mm x 872 mm x 665 mm (H x W x D)
	Channel dimension	2005 mm x 727 mm x 600 mm (H x W x D)
Weight	Net weight	< 90 Kg