

REVISIONS				
REV.	DESCRIPTION	ECN	DATE	APPROVED
F	REFER TO ECN	13806	9/27/16	EJD

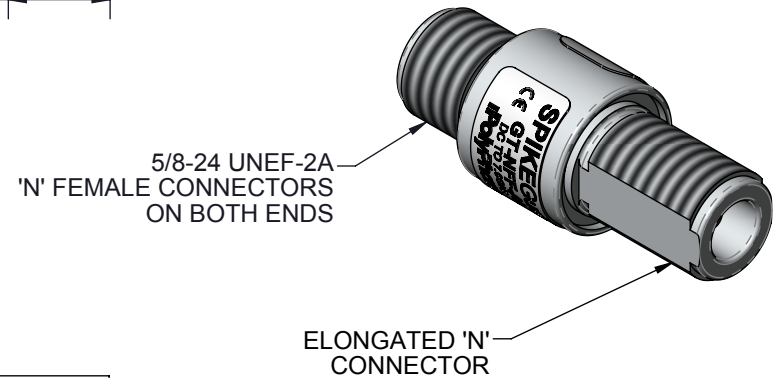
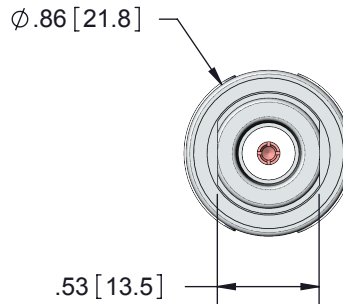
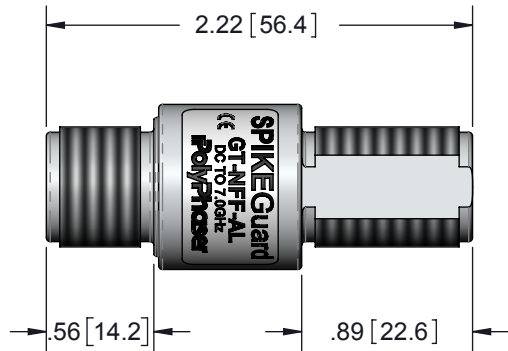

**MAXIMUM CHARACTERISTICS**

**APPLICATION:**  
 BULKHEAD MOUNT/ALUMINUM CONSTRUCTION  
 WEATHER PROOF WHEN INSTALLED

**FREQUENCY RANGE:**

dc TO 7.0GHz  
**MAX RF POWER:**  
 90W/CW @ 30MHz  
 9W/CW @ 3GHz

**VSWR:**  
 dc TO 3.0GHz @ ≤1.1 TO 1  
 dc TO 4.0GHz @ ≤1.2 TO 1  
 dc TO 7.0GHz @ ≤1.4 TO 1

**INSERTION LOSS:**  
 dc TO 4.0GHz @ ≤0.1dB  
 dc TO 7.0GHz @ ≤0.25dB

**RETURN LOSS:**  
 dc TO 3.0GHz @ ≥30dB  
 dc TO 4.0GHz @ ≥23dB  
 dc TO 7.0GHz @ ≥15dB

**DISCHARGE DEVICE CHARACTERISTICS**

**SURGE:**  
 20kA ONE TIME @ IEC 61000-4-5 8/20µs WAVEFORM

**IMPULSE SPARKOVER:**  
 500 VOLTS @ 1000V/µs  
**dc SPARKOVER ±20%:**  
 300 VOLTS

**dc HOLDOVER:**  
 80 VOLTS @ <150ms

**MAX OPERATING CURRENT:**  
 10A

**TEMPERATURE:**  
 -55°C TO +85°C STORAGE/OPERATING

**ENVIRONMENTAL:**  
 MEETS IEC 60529 IP67

**CE COMPLIANT**  
**RoHS COMPLIANT**

**HARDWARE INCLUDED:**

QTY	DESCRIPTION
1	BRACKET MOUNTING AL 5052-H32
2	NUT 8-32 HEX 18-8 SS
2	WASHER #8 410 SS INTERNAL
2	SCREW 8-32x.50 PHIL MS PAN 18-8 SS
1	O-RING 016 SILICONE
1	NUT 5/8-24 303 HEX SS

CUSTOMER APPROVAL: \_\_\_\_\_ DATE: \_\_\_\_\_

ALL DIMENSIONS SHOWN ARE FOR REFERENCE ONLY.

<small>UNLESS OTHERWISE SPECIFIED          LEADING DIMENSIONS ARE INCHES          DIMENSIONS IN [ ] ARE MILLIMETERS</small> <b>TOLERANCES:</b> FRACTIONS=± 1/32 .XX=± .01 ANGLES=± 1° .XXX=± .005 <small>NOTICE: THE INFORMATION AND DESIGN IN          THIS DOCUMENT IS THE PROPERTY OF          POLYPHASER CORPORATION. ALL RIGHTS          RESERVED.</small>	DRAWN RJD	DATE 11/10/06			SHEET 1 OF 1			
	ENG APPD JJ	3/5/07			SCALE 1:1			
	PRODUCT MGR LCJ	3/7/07	<b>TITLE</b> <b>GAS TUBE NON-REPLACEABLE</b> <b>dc-6GHz 50-100W N FEM</b> <small>CUSTOMER SPECIFICATION</small>					
	MARKETING APPD CP	3/7/07	PROJECT NO.	DOCUMENT NAME GT-NFF-AL-C	SIZE A	CAGE 30992	PROD CAT RFP	PART NUMBER GT-NFF-AL

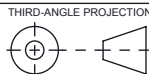

THESE COMMODITIES, TECHNOLOGY OR SOFTWARE WERE EXPORTED FROM THE UNITED STATES IN ACCORDANCE WITH THE EXPORT ADMINISTRATION REGULATIONS. DIVERSION CONTRARY TO U.S. LAW PROHIBITED.