

USER MANUAL

HYS-7.6LV-USG1
HYS-9.6LV-USG1
HYS-11.5LV-USG1

CONTENTS













1. Safety Introduction	03
1.1 Explanation of Symbols	03
1.2 Safety Information	04
2. Product Introduction	06
2.1 Product Overview	06
2.2 Product Dimensions	07
2.3 LED Indicators	08
2.4 Protection Circuitry and Controls	10
2.4.1 AFCI	10
2.4.2 RSD	10
2.5 Operating Modes	11
2.6 System Diagram	13
2.6.1 Basic Diagram	13
2.6.2 Unacceptable Diagram	14
3. Installation Instruction	15
3.1 Packing List	15
3.2 Installation Tools	15
3.3 Mounting	16
3.3.1 Selecting the Mounting Location	16
3.3.2 Mounting Inverter	17
3.4 Electrical Connection	18
3.4.1 Recommended Cable List	18
3.4.2 Opening the Wiring Box Cover	18
3.4.3 PV Cable Connection	19
3.4.4 Battery Cable Connection	20
3.4.5 AC Cable Connection	21
3.4.6 Communication Cable Connection	22
3.4.6.1 Smart Meter and CT Connection	23
3.4.6.2 DI Connection	24
3.4.6.3 DO Connection	24
3.4.6.4 BMS Connection	25
3.4.6.5 DTS Connection	25
3.4.7 Installing the Wiring Box Cover	26
3.5 Operation	27
3.5.1 Commissioning	27
3.5.2 Decommissioning	27
3.5.3 S-Miles Cloud App	28
3.5.3.1 DTS Online Setting	28





3.5.3.2 System Commissioning of Wireless Access Point (AP) Connection	30
3.5.4 ESS Operating Modes Setting	32
3.5.4.1 Export Only Mode	32
3.5.4.2 Import Only Mode	32
3.5.4.3 Online Setting	32
4. Troubleshooting	35
5. Technical Datasheet	38

1. Safety Introduction

1.1 Explanation of Symbols

The following types of safety precautions and general information symbols used in this manual must be followed during the installation, operation and maintenance of the inverter.

Symbol	Usage
 DANGER	Indicates a hazard with a high level of risk that, if not avoided, will result in death or serious injury.
 WARNING	Indicates a hazard with a medium level of risk that, if not avoided, can result in death or serious injury.
 CAUTION	Indicates a hazard with a low level of risk that, if not avoided, can result in minor or moderate injury.
 NOTICE	Indicates a situation that, if not avoided, can result in property damage. NOTICE is used to address practices not related to personal injury.
	Caution! Failure to observe any warnings contained in this manual may result in injury.
	Danger to life due to high voltages! Only qualified personnel can open and maintain the inverter.
	Burn danger due to hot surface that may exceed 60°C.
	Refer to the operating instructions.
	After the inverter is turned off, wait for at least 5 minutes before opening the inverter or touching live parts.
	Products shall not be disposed as household waste.
	Supports Type 1 DC Arc Detection on PV side.
	CSA Marking for the United States of America and Canada.



	<p>This side up! This package must always be transported, handled and stored in such a way that the arrows always point upwards.</p>
	<p>Fragile - The package/product should be handled carefully and should never be tipped over or slung.</p>
	<p>Keep dry! The package/product must be protected from excessive humidity and must be stored under cover.</p>
	<p>A maximum of six (6) identical packages can be stacked.</p>



1.2 Safety Information

This chapter contains important safety and operating instructions. For future reference, please read and keep this manual.

For the purpose of preventing personal injury and property damage, as well as ensuring the long-term operation of the product, please read and follow all the instructions and cautions on the inverter and in this user manual during installation, operation and maintenance.

Safety instructions in this manual cannot cover all precautions that should be taken. Please consider the actual conditions on site when performing operations. Any damage caused by a violation of the safety instructions in this manual shall not be the responsibility of Hoymiles.

Symbol	Usage
	<p>Danger to life from electric shock</p> <ul style="list-style-type: none"> • Before performing any work on the inverter, disconnect all DC and AC power from inverter and wait for at least 5 minutes. Hazardous voltage will exist for up to 5 minutes after disconnection from power supply. • Never insert or remove the AC or DC connections when the inverter is running. • Any live parts connected to battery ports cannot be touched before removing all the power from inverter for 5 minutes because there is still danger to life even battery voltage is lower than 60 V. • Do not touch DC conductors or any non-isolated cable ends. • The mounting location must be inaccessible to children. • Never touch either the positive or negative pole of PV connecting device. Strictly prohibit touching both at the same time.
	<p>Risk of burns from hot surfaces</p> <ul style="list-style-type: none"> • The surface of the inverter might exceed 60°C (140°F), and touching the surface may result in burns. • Do not touch hot surfaces before it cools down.

 <p>WARNING</p>	<ul style="list-style-type: none"> • Only authorized service personnel are allowed to install the inverter or perform servicing and maintenance. • All powers, both AC and DC, should be disconnected from inverter before attempting any maintenance, cleaning or working on any circuits connected to inverter. • Attempting to service the inverter yourself may result in a risk of electric shock or fire and will void your warranty. • Keep away from flammable and explosive materials to avoid fire disaster. • The installation place should be away from humid or corrosive substances. • The unit contains capacitors that remain charged to a potentially lethal voltage after the mains, battery and PV supply have been disconnected. • When accessing the internal circuit of inverter, wait for at least 10 minutes after disconnecting the power.
 <p>CAUTION</p>	<ul style="list-style-type: none"> • The inverter has a transformerless design on PV side. Neither positive nor negative terminals of PV panels should be grounded. • The frames of PV panels should be grounded for safety reasons. • Ensure that existing wiring is in good condition and no wire is undersized. • Do not disassemble any parts of inverter which are not mentioned in installation. • Authorized service personnel must use insulated tools when installing or working with this equipment. • PV modules shall have an IEC 61730 class A rating, and should be certified to UL 61730-1 and UL 61730-2 standards.
 <p>NOTICE</p>	<ul style="list-style-type: none"> • The minimum rated temperature of the wire used is 90°C (194°F). • All electrical connections must be in accordance with local and national standards. • Only with permission of the local utility grid company, the inverter can be connected to the utility grid. • Do not open the inverter cover or change any components without authorization, otherwise the warranty commitment for the inverter will be invalid. • Appropriate methods must be adopted to protect inverter from electrostatic discharge; any damage caused by ESD is not warranted by the manufacturer. • Prior to the application, please read this section carefully to ensure correct and safe application. Please keep the user manual properly. • The manual contains no instructions for user-serviceable parts. See Warranty for instructions on obtaining service. • If an error occurs, contact your local distributor or qualified electricians.

2. Product Introduction

2.1 Product Overview

The HYS-LV series is a high-performance single-phase hybrid inverter with excellent reliability. The intelligent EMS function supports self-consumption, economic, and backup modes for multi-scenario applications. Monitoring management through S-Miles Cloud allows users to remotely diagnose and track the system performance over time, offering superior energy production.

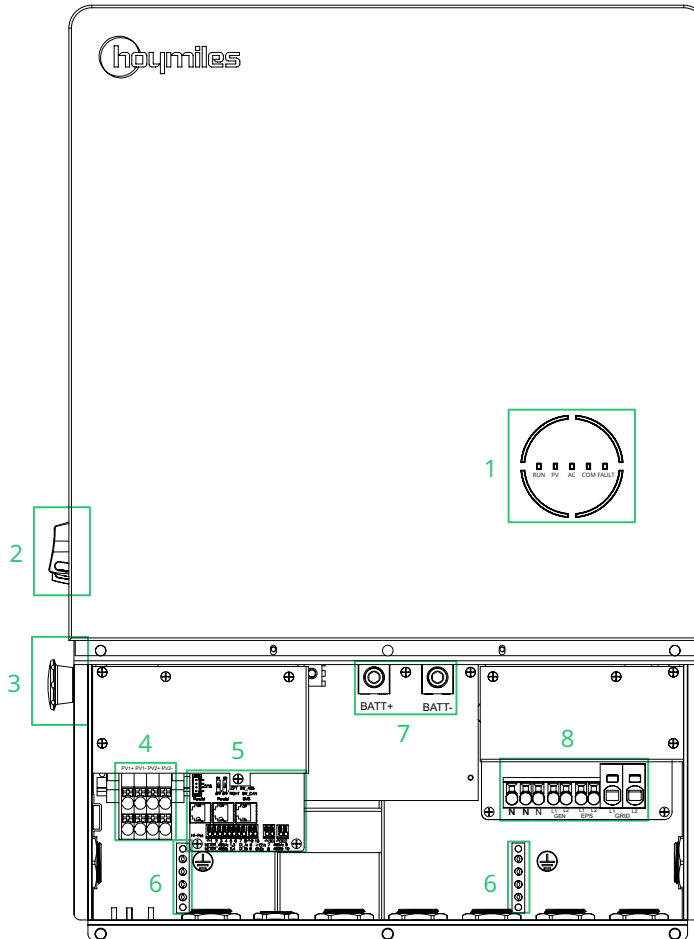

* The image shown here is for reference only. The actual product received may differ.

Object	Description
1	LED Indicators
2	DC Switch
3	Rapid Shutdown Switch
4	PV Terminals
5	Communication Port
6	Grounding Bar
7	Battery Terminals
8	AC Terminals

2.3 LED Indicators

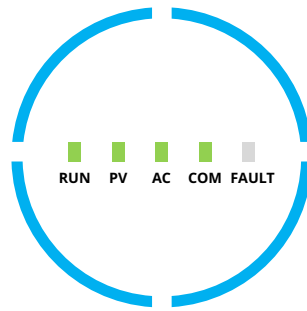

Indicator	Status	Explanation
SOC		Full circle LEDs on – SOC is 75-100%; battery is discharging or in standby Full circle LEDs blink – SOC is 75-100%; battery is charging
		3/4 circle LEDs on – SOC is 50-75%; battery is discharging or in standby 3/4 circle LEDs blink – SOC is 50-75%; battery is charging
		2/4 circle LEDs on – SOC is 25-50%; battery is discharging or in standby 2/4 circle LEDs blink – SOC is 25-50%; battery is charging
		1/4 circle LED on – SOC is 0-25%; battery is discharging or in standby 1/4 circle LED blinks – SOC is 0-25%; battery is charging
		Full circle LEDs off – No BMS communication

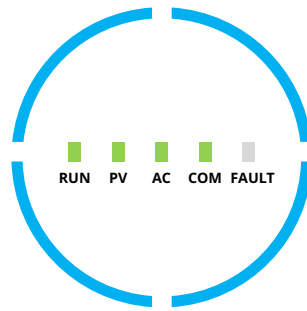

Indicator	Status	Explanation
RUN		Off – Inverter is shut down Blink 1 – Inverter is booting Blink 2 – Inverter is in bypass mode On – Inverter is turned on
PV		Off – PV voltage is low Blink 1 – PV power is low On – PV is generating power
AC		Off – Grid is disconnected and EPS is off Blink 1 – Grid is disconnected but EPS is on On – Grid is connected
COM		Off – Communication error of both meter and BMS Blink 1 – Communication failed to meter Blink 2 – Communication failed to BMS On – Both meter and BMS communications are normal
FAULT		Off – No fault On - A fault occurs Blink 1 – EPS port overload Blink 2 – ISO/RCD fault Blink 3 – Arc fault

2.4 Protection Circuitry and Controls

In accordance with relevant codes and standards, the Hoymiles HYS-USG1 series inverter is equipped with an arc fault circuit interrupter (AFCI) and rapid shutdown (RSD) for the protection circuit and control.

2.4.1 AFCI

According to UL / CSA (UL1699B) safety requirements, an electric arc with a power of 300 W or greater must be interrupted by the AFCI. The AFCI function is integrated in the HYS-LV-USG1 series inverter. Once an arc fault is detected, the corresponding error and time will be reported in the App. Within 24 hours, when the first four faults occur, the inverter will automatically clear the alarms and restart; when the fifth fault occurs, the inverter will shut down, and cannot automatically clear the alarm and restart. The inverter will resume operation after inspecting and repairing the arc fault position on-site, and manually clearing the alarm.

2.4.2 RSD

The HYS-LV-USG1 series inverter integrates the transmitter HT10. When paired with Hoymiles rapid shutdown HRSD (HRSD-1C or HRSD-2C) and powered on, HT10 sends a "permission to operate" signal to HRSD that is connected to the PV modules. Once HRSD receives this signal, it will start to work and enable PV modules to be connected in series to the hybrid inverter, thus producing power. When HRSD gets this signal, it will start to work and allows the string voltage to ramp up. When HRSD loses this signal, it will be in standby state, and the HRSD only outputs around 1 Vdc.

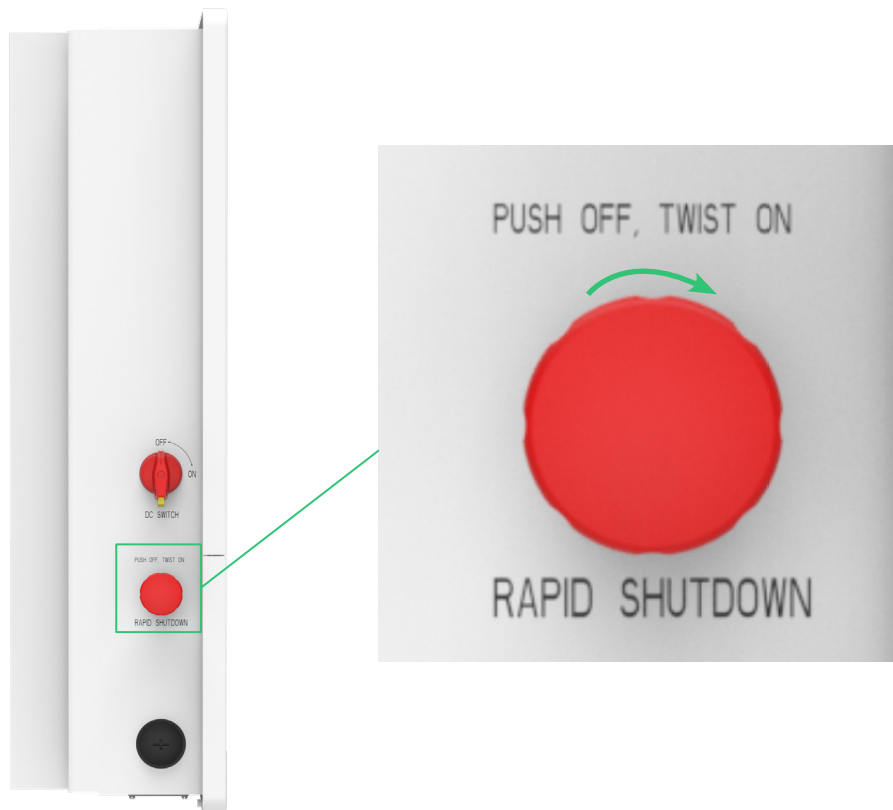

Rapid Shutdown Initiation Process:

1. Press the switch button to turn off the internal transmitter. This will initiate rapid shutdown of the PV (ramps the PV voltage down).
2. Twist the switch clockwise to turn on the transmitter. This will bring the PV voltage back up to normal.

Note:

Rapid shutdown will only initiate if HRSD have been installed on the PV modules. Without the HRSD, rapid shutdown is not possible.

2.5 Operating Modes

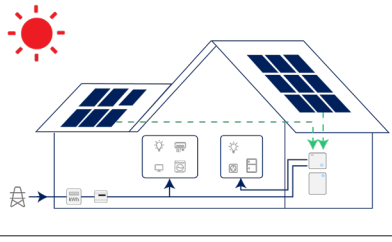
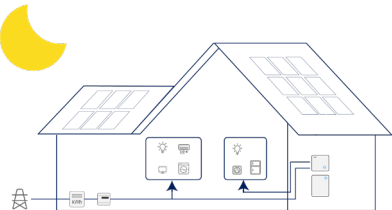
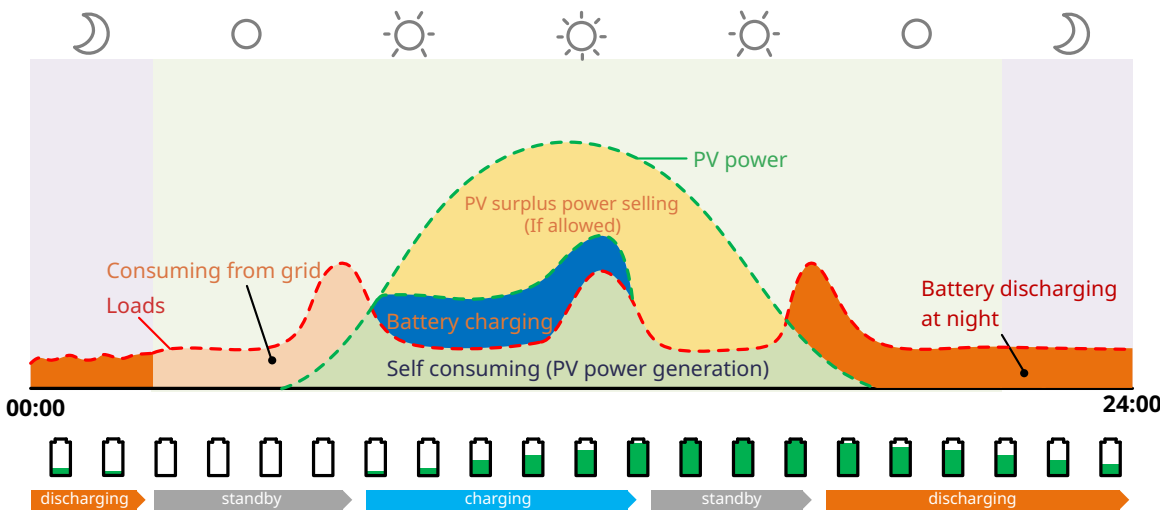
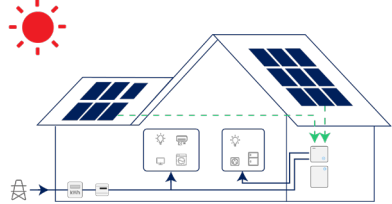
Main Operation Modes		
<p>Self-consumption Mode</p>	<p>In the daytime, solar energy supports the loads first and surplus energy is stored in the battery. When the battery is fully charged or reaches the maximum charge power, the rest energy is fed into grid (if allowed).</p> <p>At night, the battery discharges for the loads firstly and the grid will supply the loads once the battery power is not enough. In this mode, battery cannot be charged from grid at night.</p>	 
		
Power flow of self-consumption mode		
<p>Economic Mode</p>	<p>In this mode, the time of battery charge and discharge needs to be set. The battery can be forced to discharge during the preset discharge time. For instance, the battery could be discharged according to peak electricity price. And the battery can be charged by surplus PV power in the daytime or from grid during the period of valley electricity price (if allowed).</p>	

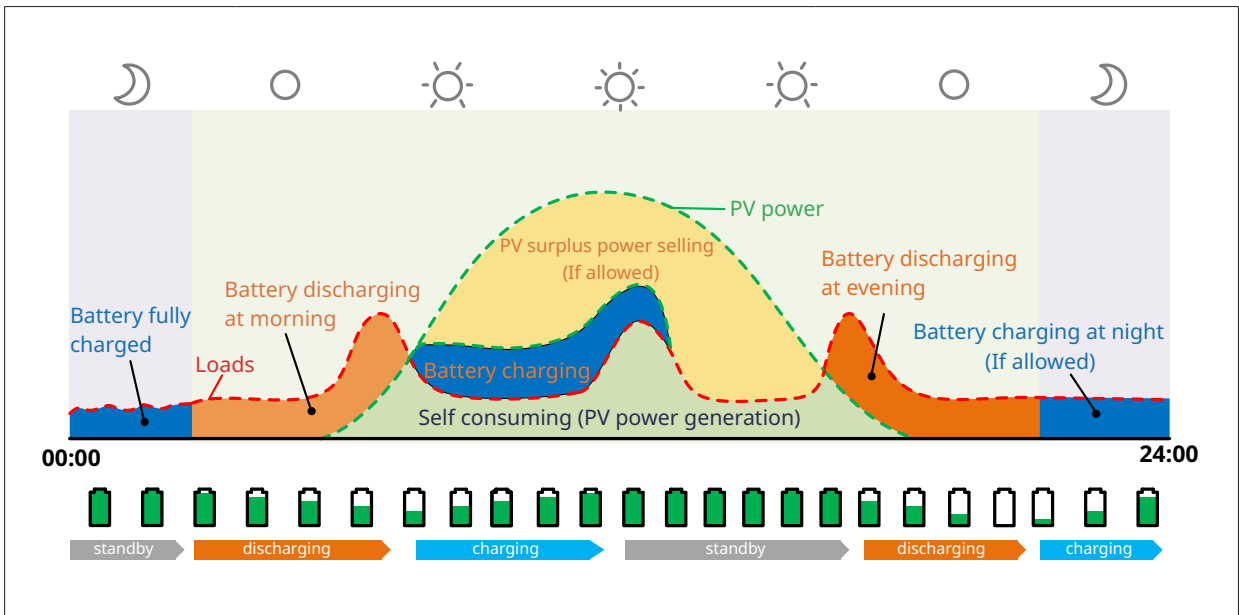

Power flow of economic mode

<p>Back-up Mode</p>	<p>In case of frequent power outages, a backup power SOC can be configured, which ensures that the battery always has enough energy to handle critical loads.</p>	
---------------------	---	--

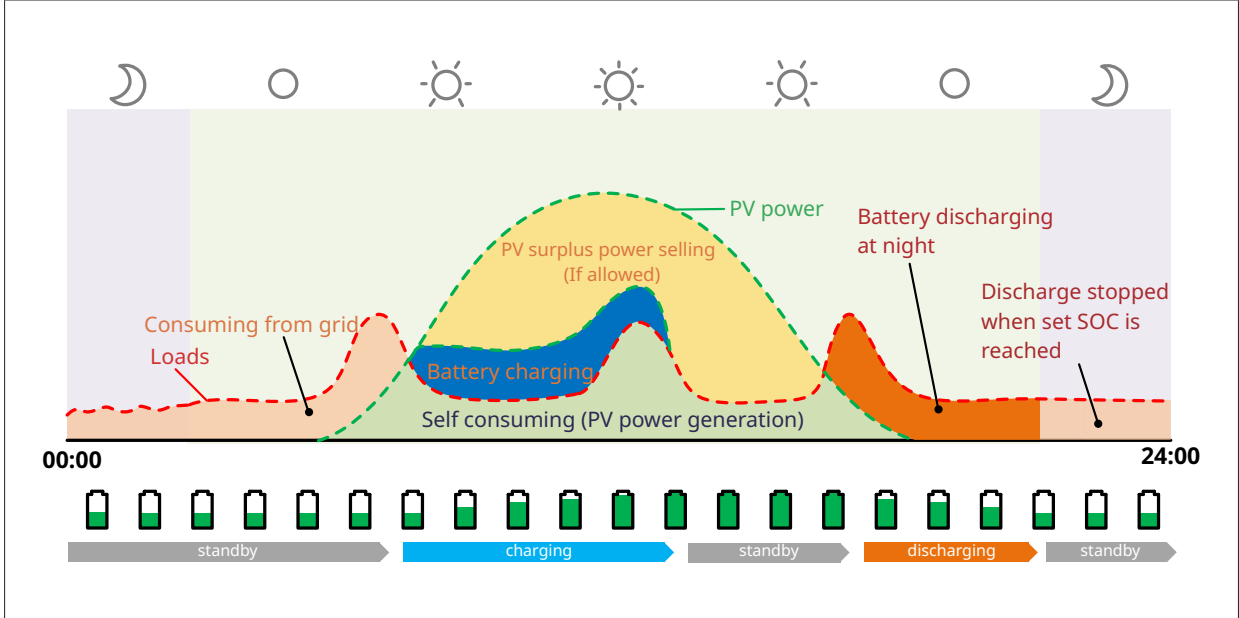

Power flow of back-up mode

2.6 System Diagram

2.6.1 Basic Diagram

The HYS-LV series inverter can be connected to a battery and PV panels to form a PV Energy Storage System (ESS). In the event of a grid outage, it can be used as an emergency power supply (EPS) through the self-consumption of solar energy. It can form a DC-coupled system for a new installation or an AC-coupled system to retrofit existing installations.

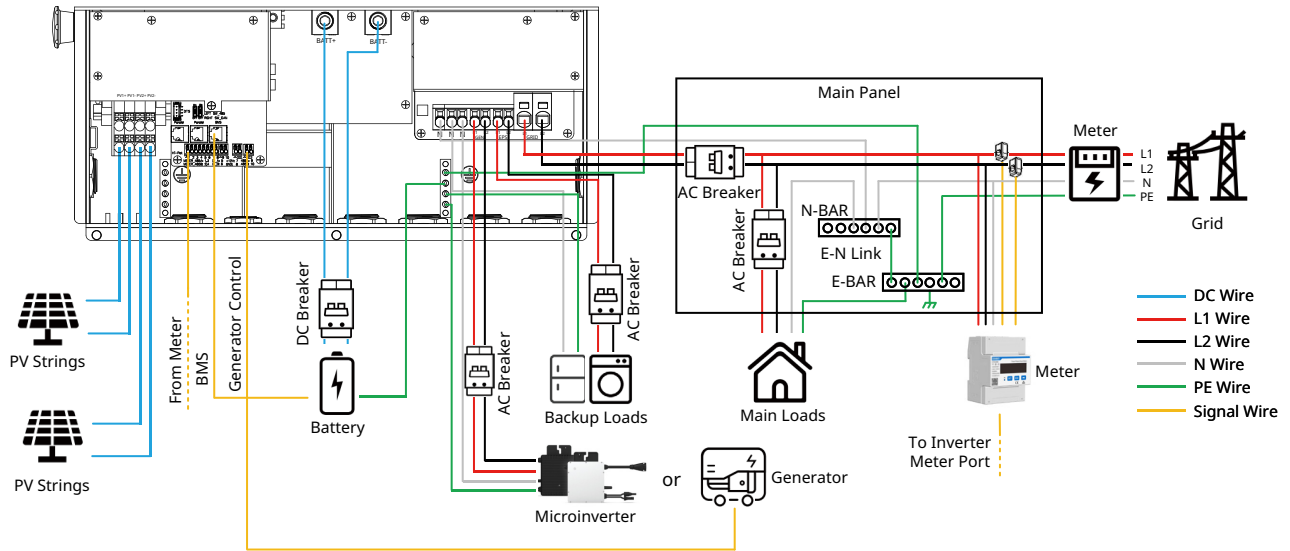

NOTICE

- This diagram is a simplified system sketch that is only intended to explain system architecture.
- Please refer to <https://www.hoymiles.com> for compatible battery list, and the user should first contact Hoymiles for technical consultation and obtain official confirmation prior to installing any battery not included in the official published list.
- Lead-acid battery is not recommended for general customers as it requires experienced installers and technicians who can fully understand the battery parameters and configure the setting and installations correctly. Please contact Hoymiles for technical support on lead-acid battery installation.

2.6.2 Unacceptable Diagram

Avoid the following installation types to prevent damage to the system or the inverter.

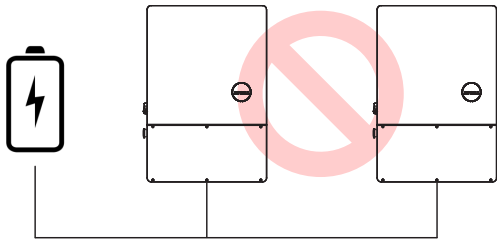

One battery cannot be connected to multiple inverters.

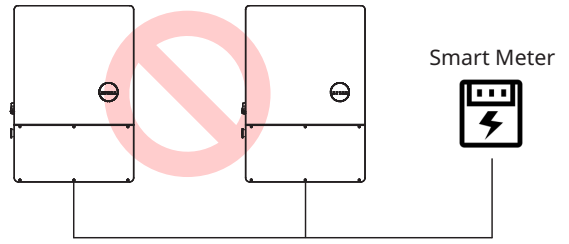

One meter cannot be connected to multiple inverters and different CTs cannot be connected to the same line cable.

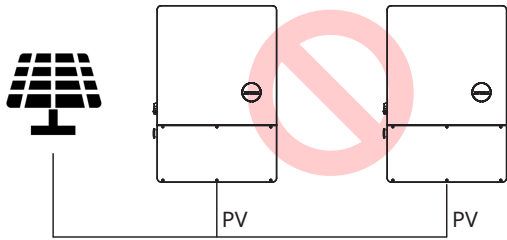

Single PV cannot be connected to multiple inverters.

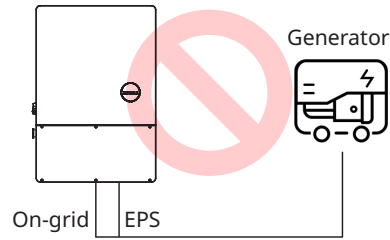

Neither EPS or on-grid port can be connected to generator directly.

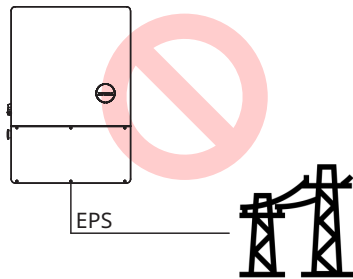

EPS port cannot be connected to grid directly.

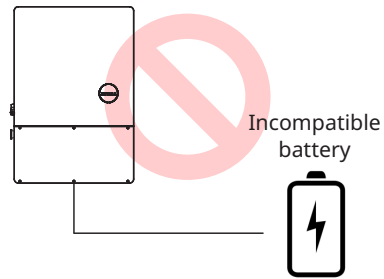

Incompatible battery cannot be connected to battery port.

3. Installation Instruction

3.1 Packing List

Please ensure that none of the components listed below are missing or damaged upon receipt of the hybrid inverter.

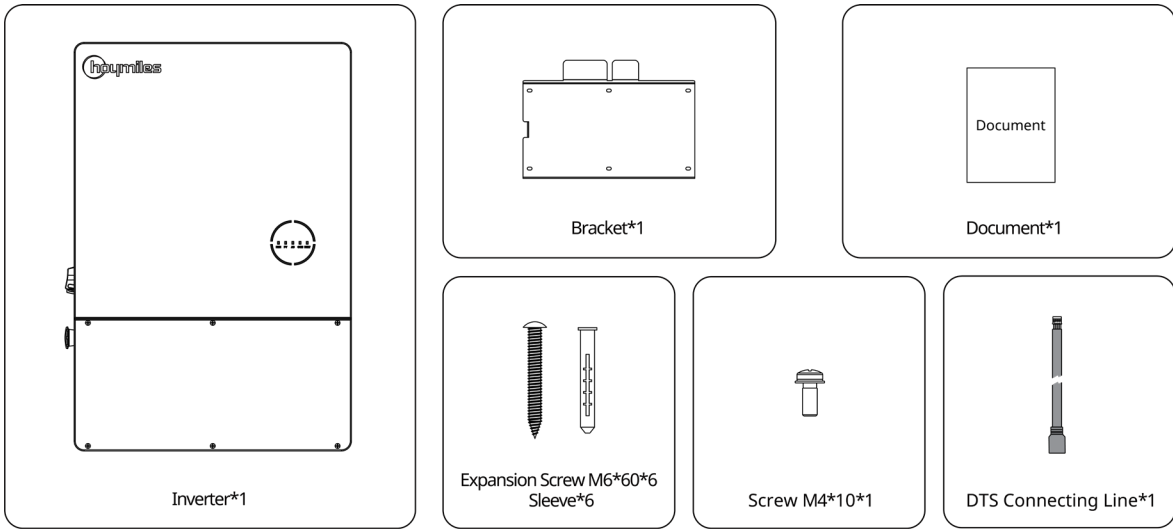

Accessories Packing List

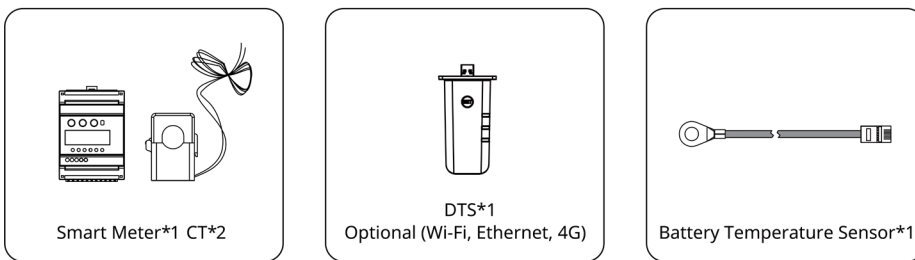

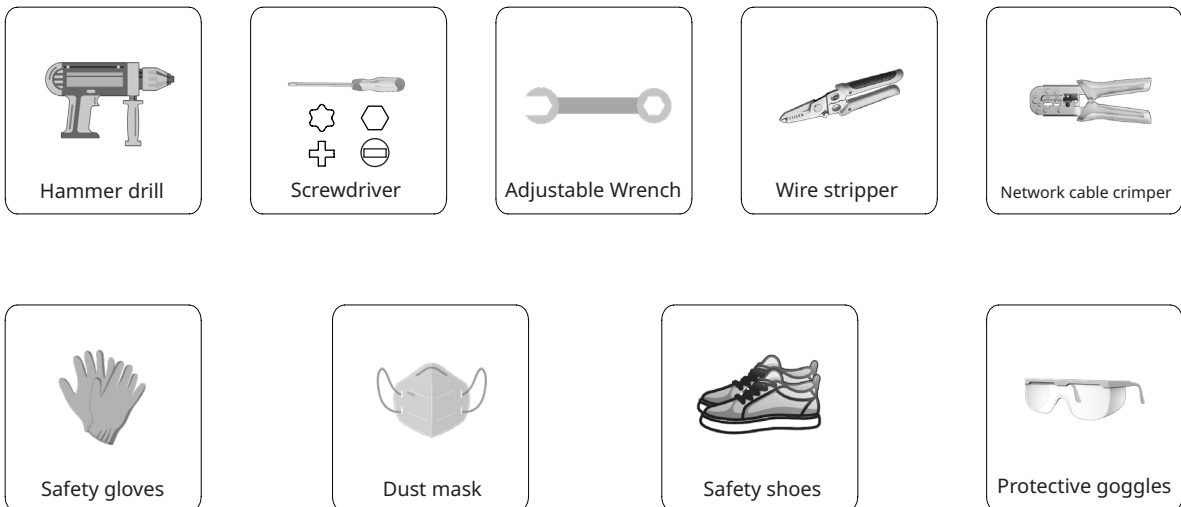

3.2 Installation Tools

The following tools are recommended in the installation process, and other auxiliary tools can also be used on site if necessary.



3.3 Mounting



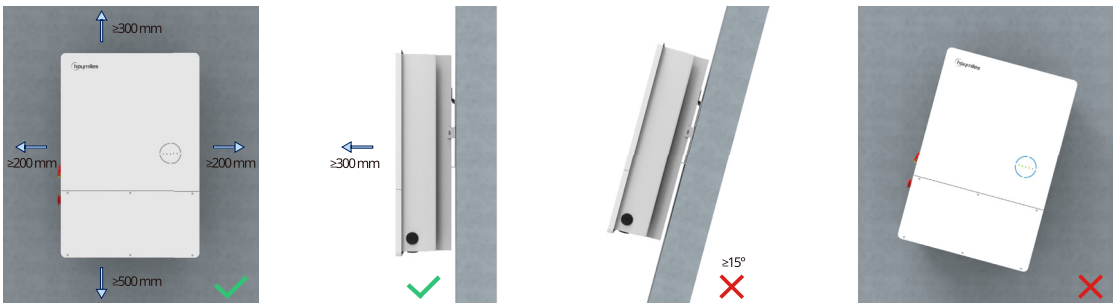

3.3.1 Selecting the Mounting Location

 <p>WARNING</p>	<ul style="list-style-type: none"> • Make sure there is no electrical connection before installation. • In order to avoid electric shock or other injuries, make sure that holes are not drilled over any electrical parts or plumbing installations.
 <p>NOTICE</p>	<ul style="list-style-type: none"> • Make sure the inverter is correctly installed according to the following list. Any incorrect installation would require a risk assessment.

Check List	
<p>1. The inverter installation should be protected by shelter from direct sunlight or bad weather such as snow, rain or lightning.</p> <p>2. The inverter should be installed on a solid surface which is suitable for the inverter’s dimensions and weight.</p> <p>3. The inverter should be installed vertically or at a maximum back tilt of 15°. Leave enough space around the inverter according to the figure below.</p> <div data-bbox="264 913 1382 1216" style="text-align: center;">  </div> <p>4. The inverter should be installed in an environment with good ventilation and heat dissipation conditions.</p> <p>5. The ambient temperature should be between -25°C (-13°F) and 45°C (113°F). High ambient temperatures will cause power derating of the inverter.</p> <p>6. The relative humidity should be less than 95%, without condensing.</p> <p>7. The inverter should be installed at eye level for convenient maintenance.</p> <p>8. The product label on the inverter should be clearly visible after installation.</p> <p>9. The inverter should be installed far from flammable materials.</p>	

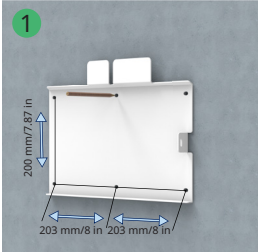
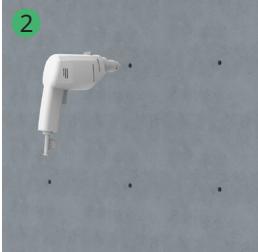
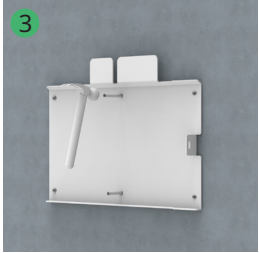
3.3.2 Mounting Inverter

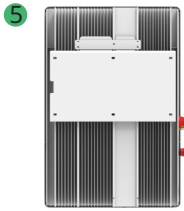
Install the inverter on the wall using the provided wall-mounting bracket and expansion plug sets.

Procedure	
<p>Step 1&2</p>	<ul style="list-style-type: none"> Position the bracket against the wall and mark the 6 drilling hole locations. Drill holes with a driller, and make sure the holes are deep enough (at least 60 mm).
<div style="display: flex; justify-content: space-around; align-items: center;"> <div style="text-align: center;">  <p>1</p> </div> <div style="text-align: center;">  <p>2</p> </div> </div>	
<p>Step 3&4</p>	<ul style="list-style-type: none"> Place sleeves in the holes, and then tighten them. Fix the wall bracket with expansion screws. Please confirm that the bracket is firmly attached to the mounting surface.
<div style="display: flex; justify-content: space-around; align-items: center;"> <div style="text-align: center;">  <p>3</p> </div> <div style="text-align: center;">  <p>4</p> </div> </div>	
<p>Step 5&6</p>	<ul style="list-style-type: none"> Mount the inverter on the bracket. Tighten the screw to secure the bracket and the inverter.
<div style="display: flex; justify-content: space-around; align-items: center;"> <div style="text-align: center;">  <p>5</p> </div> <div style="text-align: center;">  <p>6</p> </div> </div>	

3.4 Electrical Connection

 <p>WARNING</p>	<ul style="list-style-type: none"> Prior to any electrical connections, keep in mind that the inverter has dual power supplies. It is mandatory for the qualified personnel to wear personal protective equipment (PPE) during the electrical work.
--	--

3.4.1 Recommended Cable List

This data is the cable specification recommended by Hoymiles, and for proper cable specification, please refer to local laws and regulations and actual installation.

Cable (90°C/194°F, Copper)	Specification			Stripping Length
	HYS-7.6LV-USG1	HYS-9.6LV-USG1	HYS-11.5LV-USG1	HYS-7.6/9.6/11.5LV-USG1
PV Cable	12 AWG	12 AWG	12 AWG	14 mm/0.55 in
Battery Cable	2/0	4/0	4/0	23 mm/0.91 in
Battery Ground Cable	6 AWG	6 AWG	6 AWG	12 mm/0.47 in
Grid L1/L2 Cable	6 AWG	4 AWG	4 AWG	24 mm/0.94 in
Grid N Cable	10 AWG	8 AWG	8 AWG	18 mm/0.71 in
Grid Ground Cable	8 AWG	8 AWG	8 AWG	12 mm/0.47 in
EPS/GEN L1/L2/N Cable	10 AWG	8 AWG	8 AWG	18 mm/0.71 in
EPS/GEN Ground Cable	8 AWG	8 AWG	8 AWG	12 mm/0.47 in
Communication Cable	24 AWG	24 AWG	24 AWG	8 mm/0.31 in

3.4.2 Opening the Wiring Box Cover

Procedure	
Step 1	<ul style="list-style-type: none"> Loosen but do not remove the 6 screws of the wiring box cover with T20 screwdriver.
Step 2	<ul style="list-style-type: none"> Remove the cover.

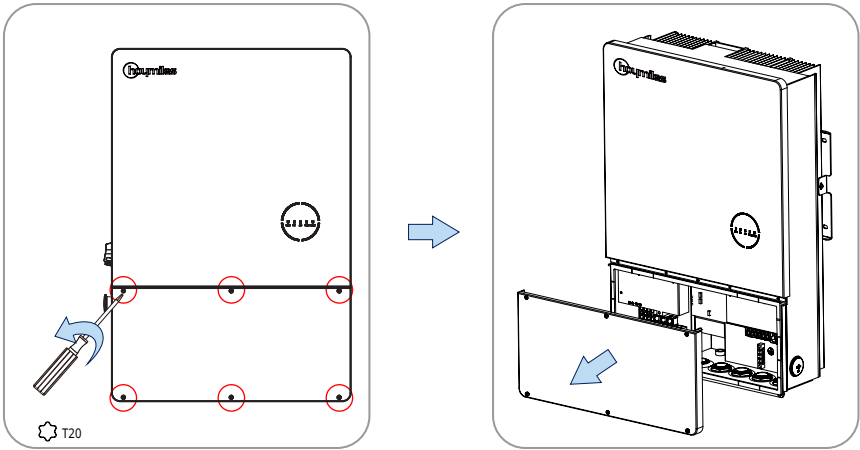

 NOTICE	<ul style="list-style-type: none"> Before connecting the cables, use an adjustable wrench to unscrew the waterproof plugs with a torque of at least 7 N·m. The size of the adjustable wrench can be adjusted to 41 mm (1.61 in) and 32 mm (1.26 in) according to the size of waterproof plugs.
--	---

3.4.3 PV Cable Connection

 WARNING	<p>Before connecting PV cable, please make sure all requirements listed below are followed.</p> <ul style="list-style-type: none"> The voltage, current and power ratings of the panels to be connected are within the allowable range of the inverter. Ensure the polarity is correct, and please refer to the technical parameters in Chapter 5 for the voltage and current limits. If the PV cables are reversely connected or if the inverter is not working properly, do not turn off the DC switch. Otherwise, it may cause a DC arc or fire or damage to the inverter. Since the inverter is a transformerless structure, please do not ground the outputs of PV panels.
---	--

Cable (90°C/194°F, Copper)	Specification			Stripping Length
	HYS-7.6LV-USG1	HYS-9.6LV-USG1	HYS-11.5LV-USG1	
PV Cable	12 AWG	12 AWG	12 AWG	14 mm/0.55 in

Procedure	
Step 1	<ul style="list-style-type: none"> Strip the cable insulation by 14 mm (0.55 in).
Step 2	<ul style="list-style-type: none"> Insert the PV cables into the terminal, and gently pull the cables backwards to ensure that they are firmly connected.

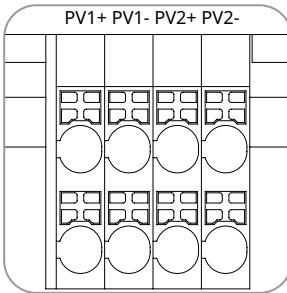

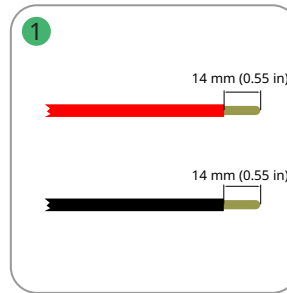

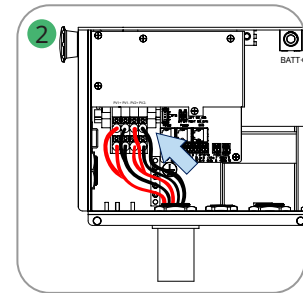



3.4.4 Battery Cable Connection

This section mainly describes the cable connections on the inverter side. Refer to the instructions supplied by the battery manufacturer for the connections on the battery side.

For batteries without a built-in DC breaker, make sure that an external DC breaker is connected.

If you need to use this hybrid inverter as a grid-tied inverter, please contact Hoymiles for help.

 WARNING	<ul style="list-style-type: none"> A two-pole DC breaker with overcurrent protection (OCP) function is compulsory to be installed between the inverter and battery. The battery may have this switch integrated. If not, an external DC switch of proper ratings should be used. Make sure the breaker mentioned above is in the "OFF" position. Before proceeding to next step, make sure that the battery voltage is 0 Vdc through a multimeter.
 NOTICE	<ul style="list-style-type: none"> Do not turn on the battery switch until all electrical connections are completed. The inverter is compatible with specific batteries. For battery models that this inverter supports, please refer to Hoymiles compatible battery list.

Cable (90°C/194°F, Copper)	Specification			Stripping Length
	HYS-7.6LV-USG1	HYS-9.6LV-USG1	HYS-11.5LV-USG1	HYS-7.6/9.6/11.5LV-USG1
Battery Cable	2/0	4/0	4/0	23 mm/0.91 in
Battery Ground Cable	6 AWG	6 AWG	6 AWG	12 mm/0.47 in

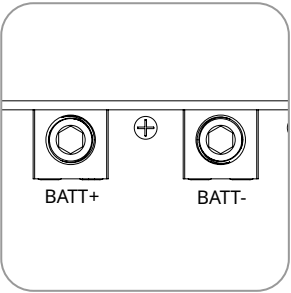
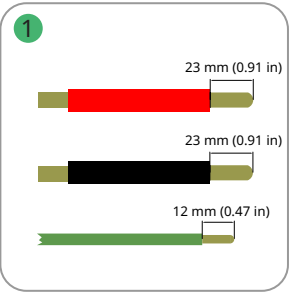
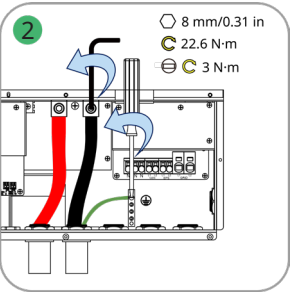
Procedure	
Step 1	<ul style="list-style-type: none"> Strip the battery cable insulation by 23 mm (0.91 in). Strip the battery ground cable insulation by 12 mm (0.47 in).
Step 2	<ul style="list-style-type: none"> Firstly, use the slotted screwdriver to unscrew the screw on the grounding bar, insert the battery ground cable, and tighten the screw. Secondly, use the hex wrench to unscrew the bolts, insert the battery cables into the terminals, and then tighten the bolts. Gently pull the battery cables and battery ground cable backwards to ensure that they are firmly connected.
<div style="display: flex; justify-content: space-around; align-items: flex-end;"> <div style="text-align: center;">  </div> <div style="text-align: center;">  </div> <div style="text-align: center;">  </div> </div>	

3.4.5 AC Cable Connection

The following diagrams are examples of connecting grid cables, and the GEN and EPS connection methods are the same as grid connection. For recommended cable specifications of EPS and GEN, please refer to the following recommended cable list.

 WARNING	<p>Before connecting the AC cables, please make sure all requirements listed below are followed.</p> <ul style="list-style-type: none"> • An independent two or three circuit breaker must be installed on the output side of the inverter to ensure safe disconnection from the grid. • Multiple inverters cannot share one circuit breaker. • Never connect a load between the inverter and the circuit breaker. • Make sure that the overcurrent protection devices (OCPDs) (breakers) are disconnected. • Before proceeding to next step, make sure that the AC voltages are 0 Vac through a multimeter.
---	---

Cable (90°C/194°F, Copper)	Specification			Stripping Length
	HYS-7.6LV-USG1	HYS-9.6LV-USG1	HYS-11.5LV-USG1	
Grid L1/L2 Cable	6 AWG	4 AWG	4 AWG	24 mm/0.94 in
Grid N Cable	10 AWG	8 AWG	8 AWG	18 mm/0.71 in
Grid Ground Cable	8 AWG	8 AWG	8 AWG	12 mm/0.47 in
EPS/GEN L1/L2/N Cable	10 AWG	8 AWG	8 AWG	18 mm/0.71 in
EPS/GEN Ground Cable	8 AWG	8 AWG	8 AWG	12 mm/0.47 in

Procedure	
Step 1	<ul style="list-style-type: none"> • Strip the grid L1/L2 cables insulation by 24 mm (0.94 in), and strip the grid N cable insulation by 18 mm (0.71 in). • Strip the grid ground cable insulation by 12 mm (0.47 in).
Step 2	<ul style="list-style-type: none"> • Firstly, use the slotted screwdriver to unscrew the screw on the grounding bar, insert the grid ground cable, and tighten the screw. Secondly, insert the L1/L2/N into the grid terminals. Gently pull the grid cable and grid ground cable backwards to ensure that they are firmly connected.

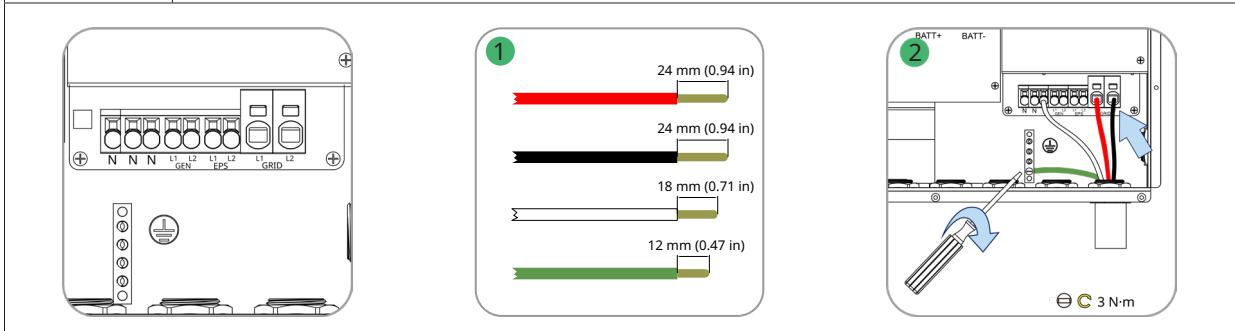

3.4.6 Communication Cable Connection

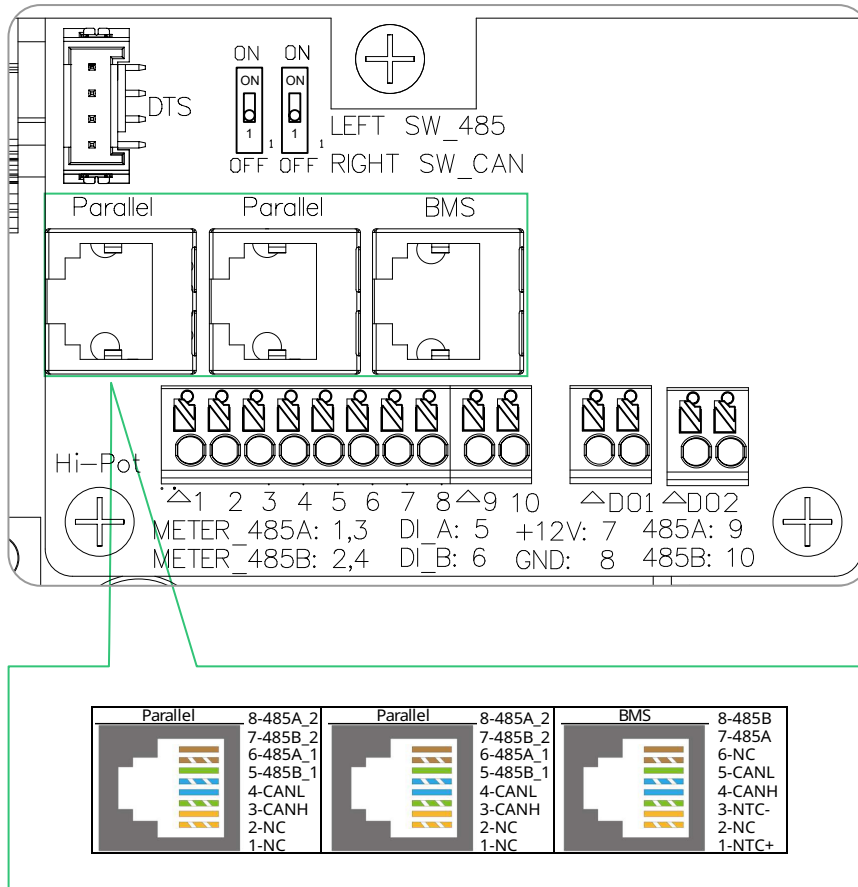

Detailed pin functions of each port on the communication interface are as follows.



Label	Description
Parallel (CANH, CANL, 485B_1, 485A_1, 485B_2, 485A_2)	For parallel operation.
BMS (NTC+, NTC-, CANH, CANL, 485A, 485B)	For Li-ion battery, communication is via CAN or RS485. For lead-acid battery, temperature is monitored via sensor through NTC+ and NTC-.
SW_485 (ON, OFF)	120 Ohm termination resistor for parallel operation.
SW_CAN (ON, OFF)	120 Ohm termination resistor for parallel operation.
Meter (485A1, 485B1, 485A2, 485B2)	For the Smart Meter. One is connected to the grid side, and the other is connected to the third-party inverter.
DI (DI_A, DI_B)	Dry contact input of external bypass contactor.
+12V / GND	Reserved.
DO1 (NO1, COM1)	Dry contact output. The DO1 can be set to one of the functions as follows: Earth Fault Alarm, Load Control and Generator Control.
DO2 (NO2, COM2)	Dry contact output. The DO2 will control the bypass contactor under certain logic.

3.4.6.1 Smart Meter and CT Connection

The smart meter and CT in the accessory box are necessary for system installation, and are used to provide the operating condition of the inverter via RS485 communication.

 WARNING	<ul style="list-style-type: none"> Before connecting the smart meter and CT, ensure that the AC cable is totally isolated from the AC power source.
 NOTICE	<ul style="list-style-type: none"> One smart meter can be used with only one inverter. One CT must be used for one smart meter, and CT 1-1 and CT 1-2 must be connected on the same phase with the smart meter power cable. There is a symbol (arrow) or label on the surface of CT that indicates the correct mechanical orientation of the CT on the conductor under measurement. Please identify the arrow or label before installing the CT.

Cable (90°C/194°F, Copper)	Specification			Stripping Length
	HYS-7.6LV-USG1	HYS-9.6LV-USG1	HYS-11.5LV-USG1	HYS-7.6/9.6/11.5LV-USG1
L1/L2/N Cable	14 AWG	14 AWG	14 AWG	6 mm/0.24 in
RS485 Cable (shield twisted pair)	24 AWG	24 AWG	24 AWG	8 mm/0.31 in

Procedure	
Step 1	<ul style="list-style-type: none"> Clamp CT 1-1 and CT1-2 to L1/L2 cable, respectively connect the white and blue wire of CT 1-1 to terminals 1/3, and repectively connect the white and blue wire of CT 1-2 to terminals 4/6. The arrow on the surface of CT should point to the grid.
Step 2	<ul style="list-style-type: none"> Connect grid L1/L2/N to meter’s terminals 2/5/10.
Step 3	<ul style="list-style-type: none"> Respectively connect meter A and meter B to inverter METER_485A and METER_485B.

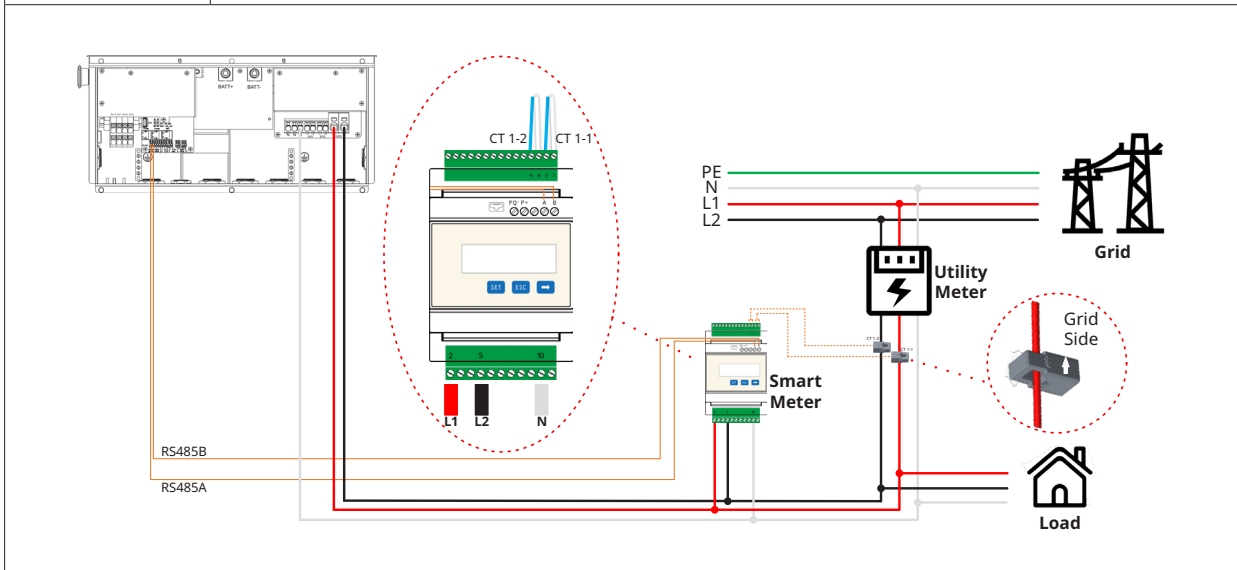

3.4.6.2 DI Connection

There is an integrated DI (IN+, IN-) as the dry contact input to the bypass contactor of the inverter.

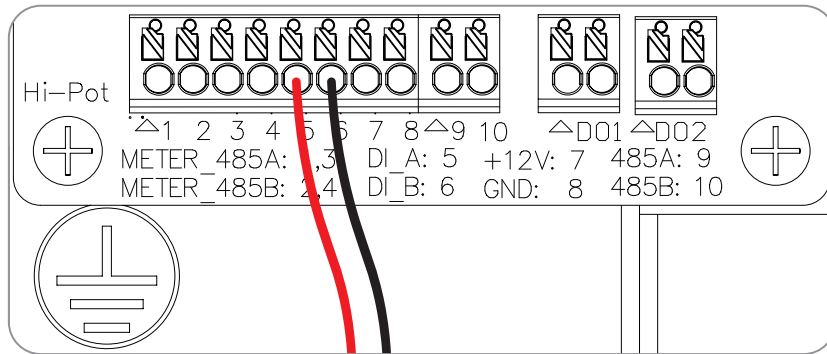

3.4.6.3 DO Connection

The inverter has integrated a multiple-function dry contact (DO1 and DO2). The DO1 can be set to one of the functions as follows, Earth Fault Alarm, Load Control and Generator Control. The DO2 can control the external bypass contactor if installed.

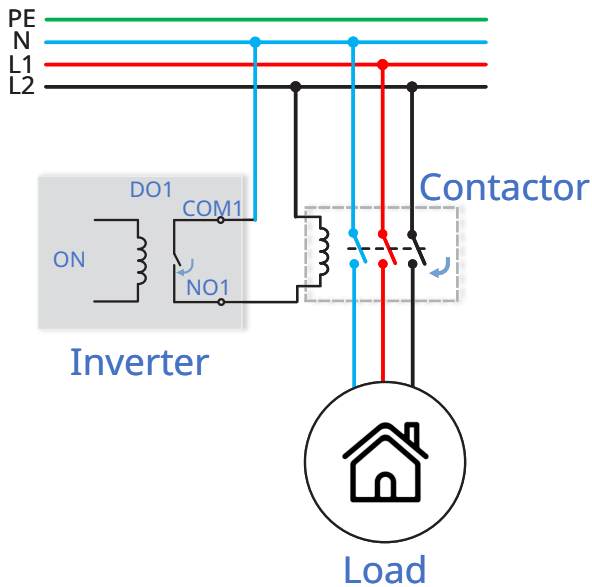
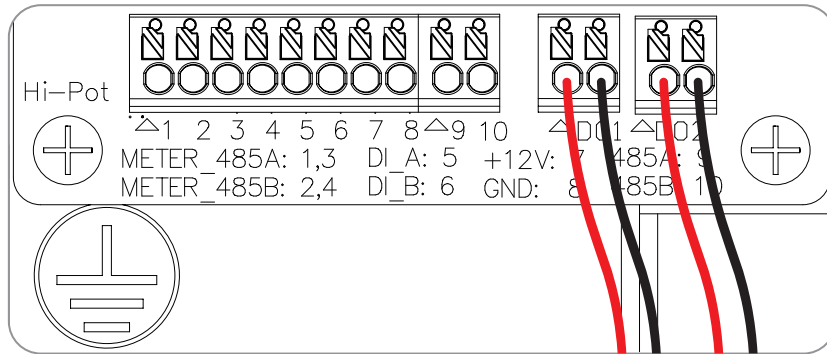

DO1-Load Control

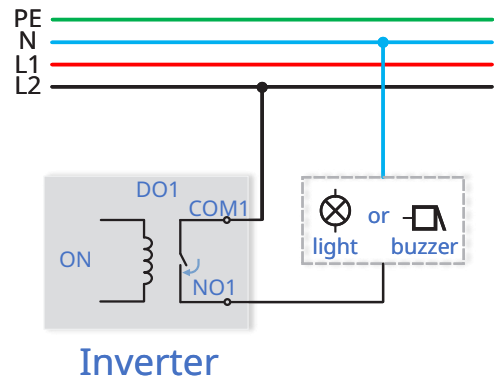

DO1-Earth Fault Alarm

3.4.6.4 BMS Connection

BMS is used to communicate with compatible Li-ion battery. If lead-acid battery is used to work with this inverter, the battery temperature sensor in the packing list shall be used to monitor the battery temperature.

Procedure	
Step 1	<ul style="list-style-type: none"> Strip the communication cable insulation with an ethernet wire stripper, and lead the corresponding signal cables out. Insert the stripped communication cable into the RJ45 plug in the correct order, and crimp it with a network cable crimper.
Step 2	<ul style="list-style-type: none"> Insert the RJ45 plug into the BMS port, and gently pull the cable backwards to make sure that the plug is completely connected to the BMS port. The pin definition of BMS or battery temperature sensor is shown in the "3.4.6 Communication Cable Connection".

3.4.6.5 DTS Connection

DTS-4G-G1 and DTS-Wi-Fi-G1 Procedure	
Step 1	<ul style="list-style-type: none"> Remove the DTS port cover plate.
Step 2	<ul style="list-style-type: none"> Insert the DTS into the USB port, and tighten the screws.
Step 3	<ul style="list-style-type: none"> Respectively connect the ends of DTS connecting line to the corresponding ports.

DTS-Ethernet-G1 Procedure	
Step 1&2	<ul style="list-style-type: none"> Remove the DTS port cover plate. Insert the DTS-Ethernet into the USB port, and tighten the screws.
Step 3&4	<ul style="list-style-type: none"> Respectively connect the ends of DTS connecting line to the corresponding ports. Unscrew the swivel nut from the connector.
Step 5	<ul style="list-style-type: none"> Insert the RJ45 plug (pin definition is shown in the right figure) into the connector until there is an audible click sound. (Note that the RJ45 plug with cable sheath cannot be inserted.) Thread the cable of an appropriate length through the connector. Tighten the cable gland.

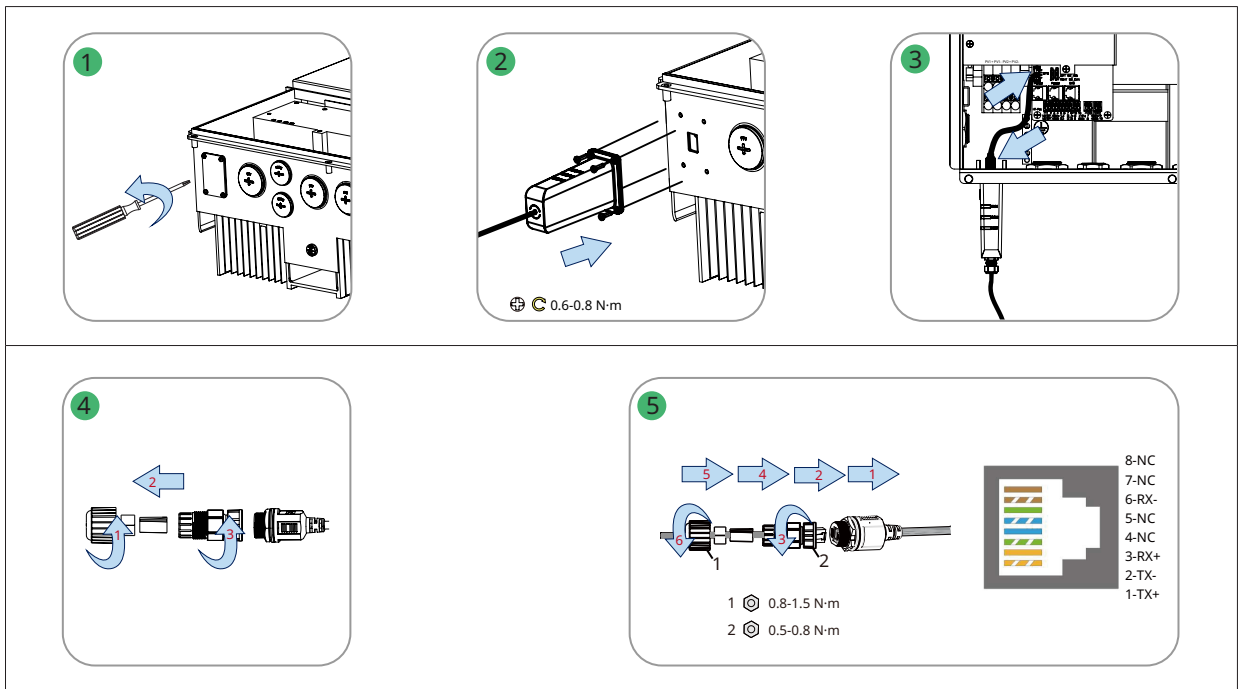

Indicator	Status	Description
RUN	ON	DTS is powered on.
	OFF	DTS is not powered on.
COM	ON	Proper communication with the inverter.
	OFF	Improper communication with the inverter.
NET	ON	Proper communication with S-Miles Cloud.
	OFF	Improper communication with S-Miles Cloud.
	BLINK	Improper communication with S-Miles Cloud, but the network is connected.

3.4.7 Installing the Wiring Box Cover

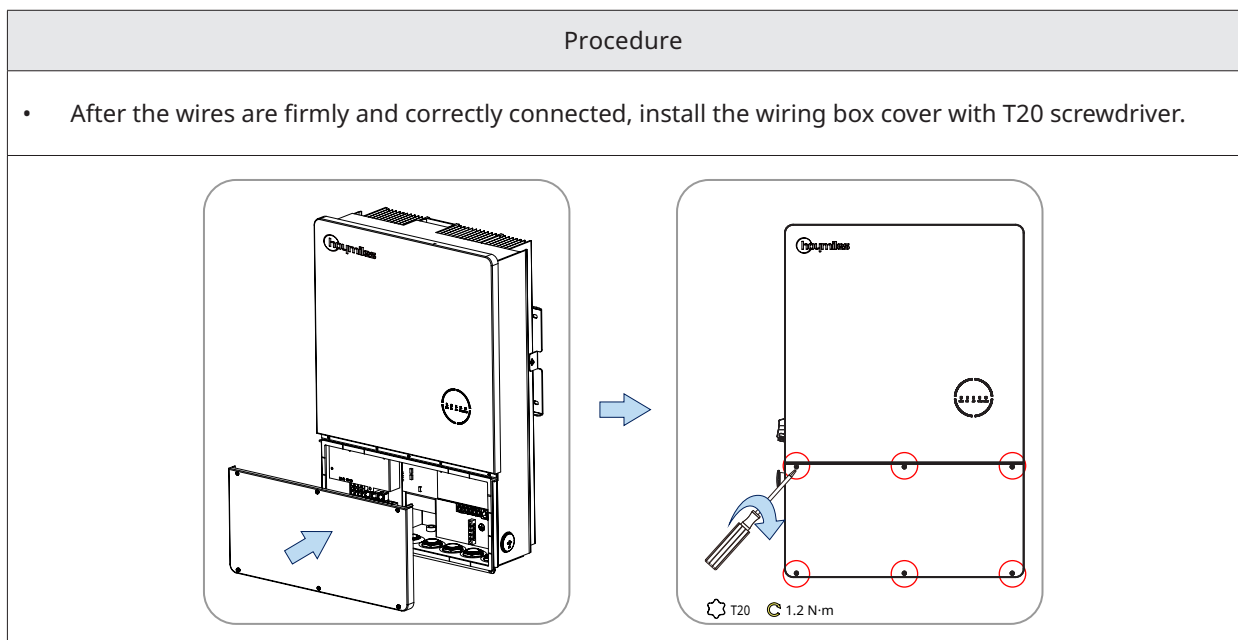

3.5 Operation

3.5.1 Commissioning

 NOTICE	<p>Before the commissioning of inverter, make sure:</p> <ul style="list-style-type: none"> • The inverter DC switch and external circuit breaker are disconnected; • Check wiring according to "3.4 Electrical Connection"; • Check whether the rapid shutdown switch is on the "ON" position; • Check whether the grid voltage is within the permissible range through the multimeter before turning on the AC switch; • Unused terminals must be sealed using corresponding sealing plugs; • Nothing is left on the top of the inverter and battery; • Cables are routed in a safe place or protected against mechanical damage; • Warning signs and labels are intact.
--	---

System Power-on Procedure	
Step 1	If the inverter is connected to the battery, turn on the battery power switch and DC breaker.
Step 2	Turn on the AC breaker between the inverter and the grid.
Step 3	Rotate the DC switch to "ON" if the inverter is connected to the PV strings.
Step 4	Check whether the inverter is operating properly through the inverter indicators status.

3.5.2 Decommissioning

 NOTICE	<p>After powering off the inverter, following the steps below if needed:</p> <ul style="list-style-type: none"> • Wait at least 5 minutes after the LED indicators turn off to release the internal energy; • Disconnect all cables; • Remove DTS and power meter; • Remove the inverter from the wall, and remove the bracket if necessary, and finally pack the inverter and accessories; <p>Please strictly follow the procedure below. Otherwise, it will cause lethal voltages or unrecoverable damage to the inverter.</p>
--	--

System Power-off Procedure	
Step 1	Stop the inverter from working via Hoymiles App.
Step 2	Disconnect the AC breaker between the inverter and the grid.
Step 3	Rotate the DC switch to "OFF".
Step 4	Turn off the DC breaker between the inverter and the battery.
Step 5	Check whether the inverter indicators are off.

3.5.3 S-Miles Cloud App

The S-Miles Cloud App has been developed for Hoymiles inverter and offers the following features:

- a. Network configuration;
- b. Local installation assistant;
- c. System monitoring.

Please download the S-Miles Cloud App from the Google Play Store or the Apple App Store. The QR code below can also be scanned to download the App. Please refer to the S-Miles Cloud User Manual from www.hoymiles.com/resources/download/ for details.



S-Miles Installer

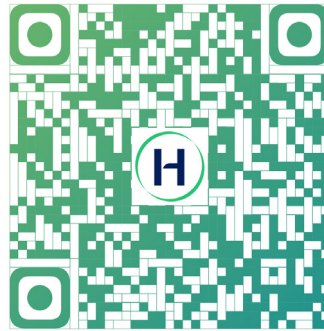

S-Miles End-user

3.5.3.1 DTS Online Setting

1. Search “Hoymiles” in the App Store (iOS) or the Play Store (Android), or scan the QR code to download the Hoymiles Installer App.
2. Open the app and log in with your installer account and password. For new Hoymiles installers, please apply for an installer account from your distributor in advance.
3. Use the App to connect to the DTS.
(a) Open the Installer App on smartphone/tablet and log in. Click on “O&M” at the bottom of the page, and then click on “Network Config”.

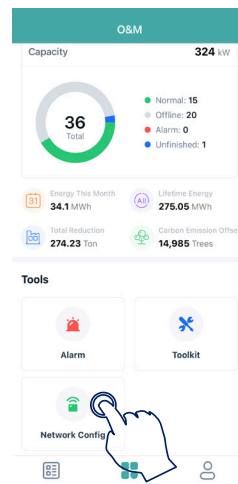

(b) Select the DTS's wireless network and click "Connect". (The network name of the DTS consists of DTS and product serial number, and the default password is ESS12345.)

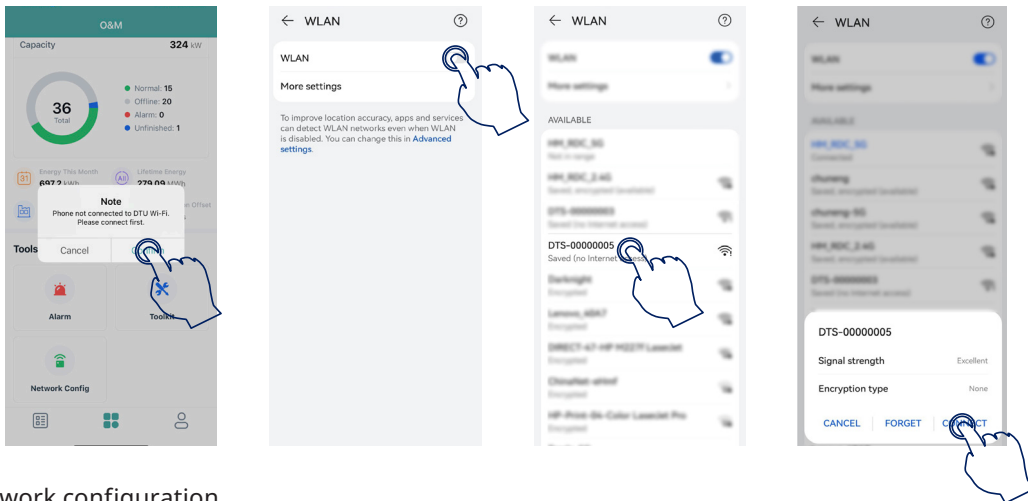

4. Network configuration.

(a) Upon successful connection, click on "Network Config" again and access the Network Configuration page.

(b) Select the router Wi-Fi and enter the password.

(c) Click on "Send to DTU".

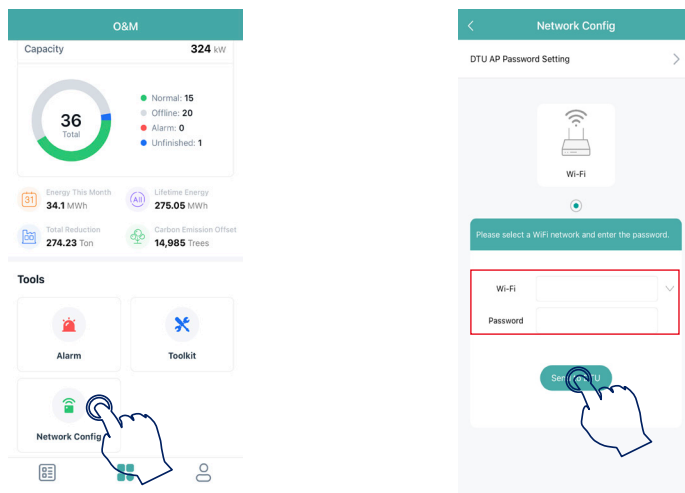

5. Check the DTS indicator for a solid blue light, which signifies a successful connection.

The network configuration takes about 1 minute, please be patient. If the network is not connected, please check the internet as instructed.

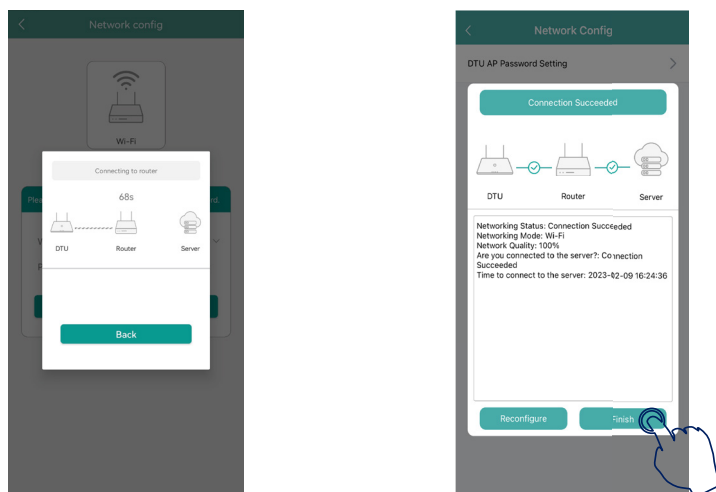

3.5.3.2 System Commissioning of Wireless Access Point (AP) Connection

1. Connect the wireless network of DTU. Open the App, click "Toolkit → Meter Location" to configure the grid side meter. The serial number (SN) can be entered manually or identified through scanning the QR code.

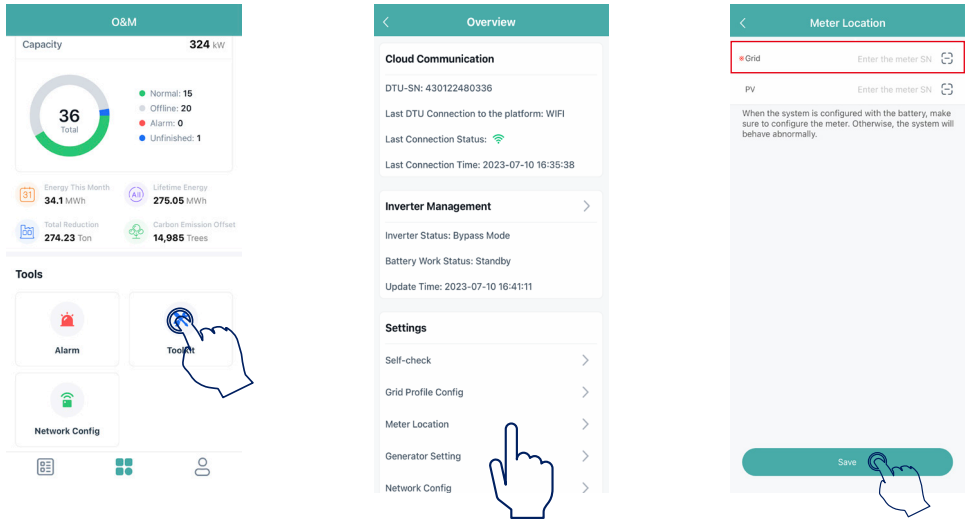

2. Click "Grid Profile Config → ESS Advanced Config → Meter Model" to choose "Two-phase Meter", and click "Save".

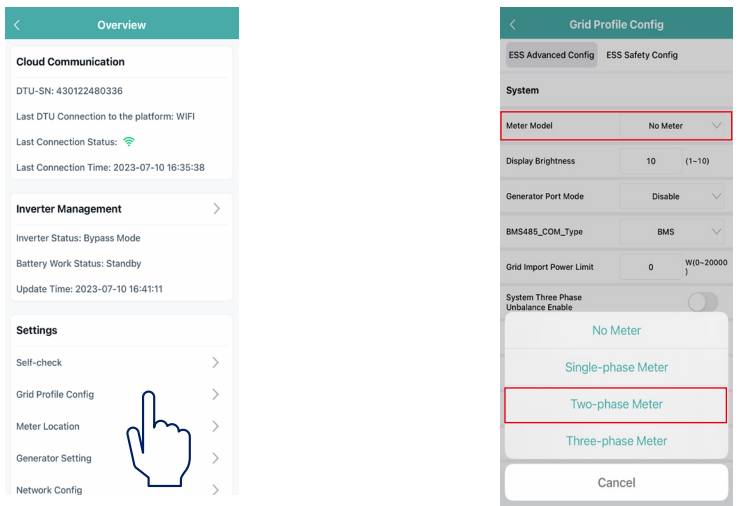

3. Click "Inverter Management → Battery Setting" to set battery type, BMS protocol and battery capacity, and click "Save". (The default setting is "No battery".)

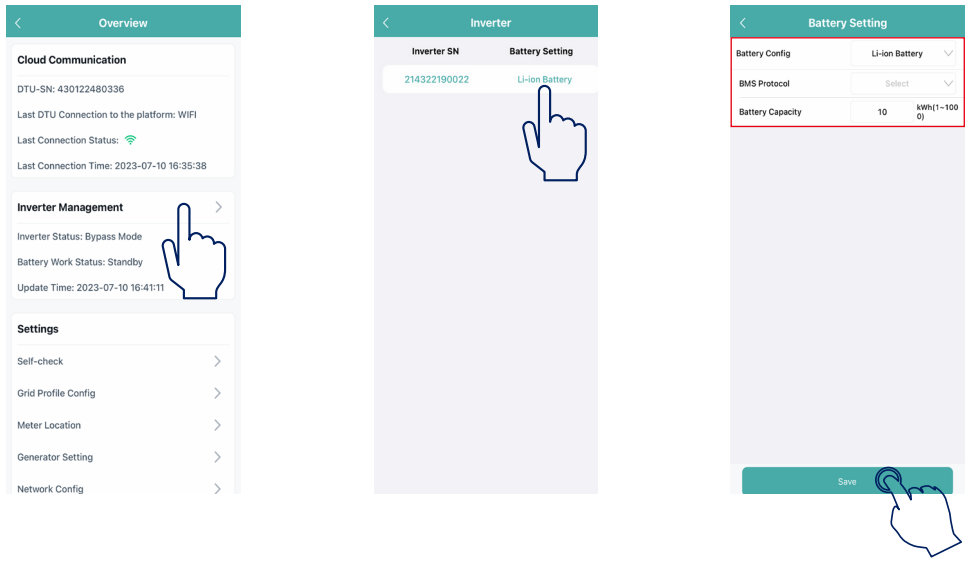

4. Click “Generator Setting”, choose the corresponding button according to whether the device connected to the GEN port is “PV Generator” or “Diesel Generator”, and click “Save”. (The default option is “None”).

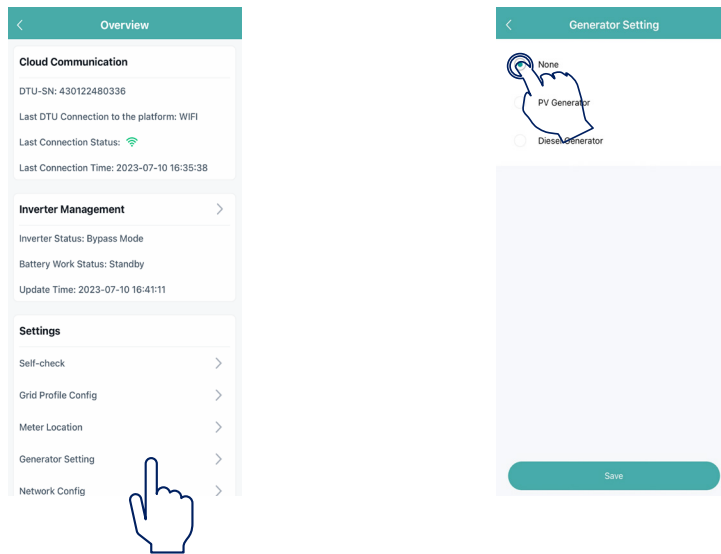

5. Make sure that all cables including DC cables, AC cables and communication cables are properly connected, and DC and AC switches are turned on, and then click “Self-check”. If there is any problem, solve the problem, and click “Self-check” again to confirm that the problem is completely solved. If there is no problem, this interface will display green checkmarks on the right of these items.

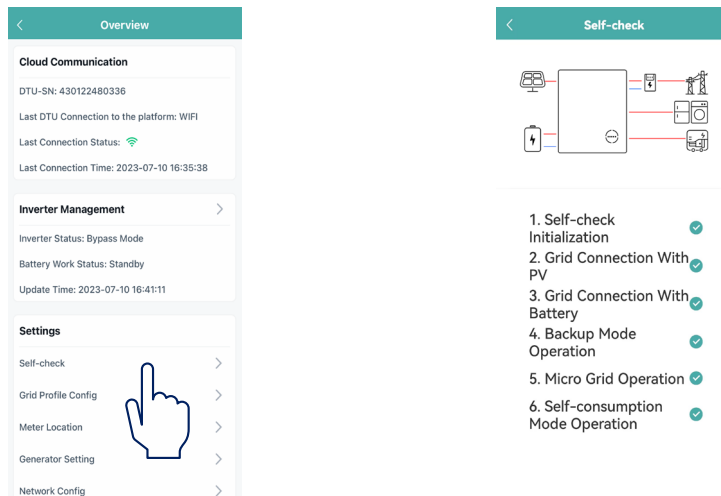

3.5.4 ESS Operating Modes Setting

ESS Operating Mode is only for United States, Canada and Mexico. It is to restrict the energy exchange between the Area EPS and the energy storage sub-system (ESS). Hoymiles energy storage system has two ESS operating modes, Export Only Mode and Import Only Mode. The ESS Operating Modes can only be set through S-Miles Cloud Monitoring Platform <https://global.hoymiles.com/>.

3.5.4.1 Export Only Mode

If Export Only Mode is chosen, the ESS may export active power to the Area EPS during discharging but shall not import active power from the Area EPS for ESS charging purposes. Under this mode, the Generation Control Function (GCF) is disabled, the grid input power is limited to 0 W.

3.5.4.2 Import Only Mode

If Import Only Mode is chosen, the ESS may import active power from the Area EPS for charging purposes but shall not export active power from the ESS to the Area EPS. Under this mode, the GCF is enabled, and the feed-in power is limited to 0 W.

3.5.4.3 Online Setting

1. Choose the plant you want to edit and click the “O&M → ESS Operating Modes Setting” button to perform ESS Operating Modes setting.

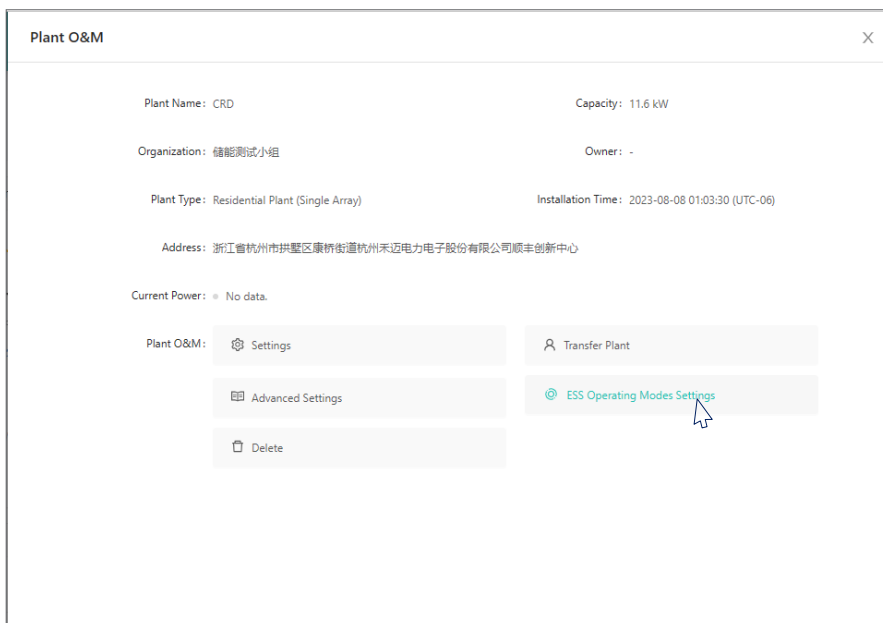
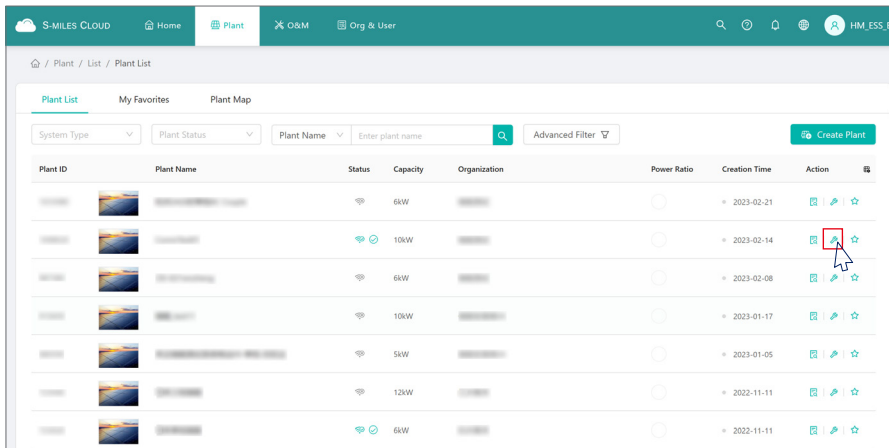

2. Click the "Export Only Mode" or "Import Only Mode", click "Get verification code", enter your E-mail, and click the "Send" button to get a verification code. After you send the request, a single-use verification code will be sent to your E-mail. Enter the verification code and click "Configuration" to complete the setting.

ESS Operating Modes Settings [X]

Export Only Mode: [Red box around toggle]

The ESS may export active power to the Area EPS during discharging, but shall not import active power from the Area EPS for ESS charging purposes.

Import Only Mode: [Red box around toggle]

The ESS may import active power from the Area EPS for charging purposes, but shall not export active power from the ESS to the Area EPS.

*** Note**

1. ESS Operating Modes Settings restrict power exchange between the Area EPS and the energy storage sub-system (ESS).
2. Request a verification code from the platform for ESS Operating Modes Settings.
3. After sending the request, a single-use verification code would be sent to account email.
4. This verification code would be invalid when the configuration takes effect or when the verification code was received for 5 minutes.

[Cancel] [Get verification code] [Red box around button]

Get a verification code [X]

mailbox: [Red box around input]

* Captcha: [Red box around input] [Send] [Red box around button]

[Elimination] [Configuration] [Red box around button]

Plant name:

Your verification code is 326393 (valid within 5 minutes).

To ensure the security of your account, please do not provide this verification code to anyone.

This email is sent automatically by the system, please do not reply directly.

3. The verification would be invalid when the configuration takes effect or when the verification code was received for 5 minutes. If you correctly enter the verification code within the valid time, this page will display "Command executed"; if you enter wrong verification code or enter the code beyond 5 minutes, this page will display "pvm.ctl.verification_code_invalid_or_error".

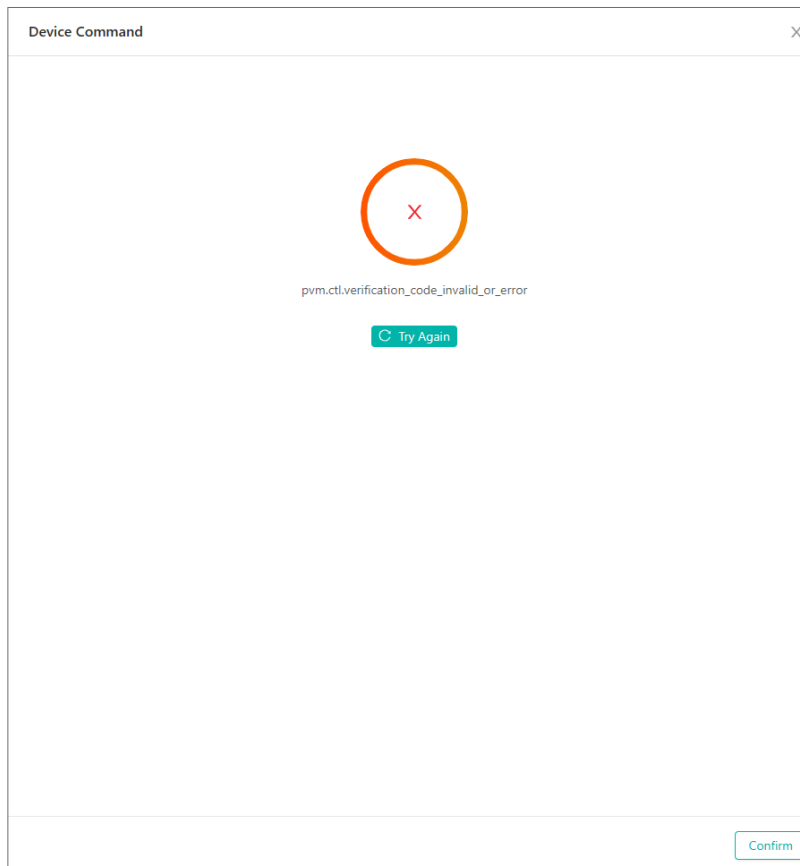
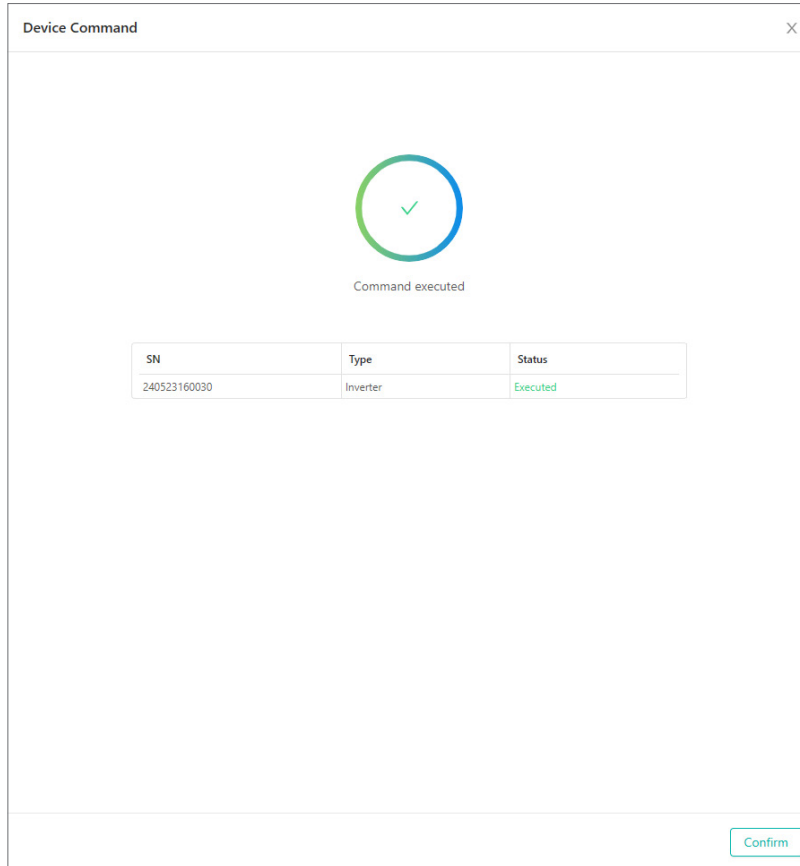

4. Troubleshooting

When the system is in alarm, please log into the S-Miles Cloud App to review. The possible causes and their troubleshooting are detailed in the following table:

Display	Possible Cause	Handling Suggestions
Grid Overvoltage	The grid voltage is higher than the permissible range.	Generally, the inverter will reconnect to the grid after the grid recovers. If the alarm occurs frequently: 1. Make sure the ESS safety configuration of the inverter is set correctly. 2. Make sure that the grid voltage in your area is stable and within the normal range. 3. Check whether the cross-sectional area of the AC cable meets the requirement. 4. If the alarm persists, contact Hoymiles technical support team.
Grid Undervoltage	The grid voltage is lower than the permissible range.	Generally, the inverter will reconnect to the grid after the grid recovers. If the alarm occurs frequently: 1. Make sure the ESS safety configuration of the inverter is set correctly. 2. Make sure that the grid voltage in your area is stable and within the normal range. 3. Check whether the AC cable is firmly in place. 4. If the alarm persists, contact Hoymiles technical support team.
Grid Overfrequency	The grid frequency is higher than the permissible range.	Generally, the inverter will reconnect to the grid after the grid recovers. If the alarm occurs frequently: 1. Make sure the ESS safety configuration of the inverter is set correctly. 2. Make sure that the grid frequency in your area is stable and within the normal range. 3. If the alarm persists, contact Hoymiles technical support team.
Grid Underfrequency	The grid frequency is lower than the permissible range.	
No Grid	The inverter detects that there is no grid connected.	Generally, the inverter will reconnect to the grid after the grid recovers. If the alarm occurs frequently: 1. Check whether the grid supply is reliable. 2. Check whether the AC cable is firmly in place. 3. Check whether the AC cable is correctly connected. 4. Check whether the AC circuit breaker is disconnected. 5. If the alarm persists, contact Hoymiles technical support team.
Residual Current Fault	The residual leakage current is too high.	1. The alarm can be caused by high ambient humidity, and the inverter will reconnect to the grid after the environment is improved. 2. If the environment is normal, check whether the AC and DC cables are well insulated. 3. If the alarm persists, contact Hoymiles technical support team.
PV Reverse Connection	The inverter detects that the PV strings are reversely connected.	1. Check whether the corresponding string is of reverse polarity. If so, disconnect the DC switch and adjust the polarity when the string current drops below 0.5 A. 2. If the alarm persists, contact Hoymiles technical support team.
PV Undervoltage	The PV voltage is lower than the permissible range.	1. Check whether the DC cable is firmly in place. 2. Check whether there is a PV module shaded. If so, remove the shade and ensure the PV module is clean. 3. Check whether the PV module is in abnormal aging. 4. If the alarm persists, contact Hoymiles technical support team.
PV Overvoltage	The PV voltage is higher than the permissible range.	1. Check the specification and numbers of corresponding string PV modules. 2. If the alarm persists, contact Hoymiles technical support team.

Display	Possible Cause	Handling Suggestions
Over Temperature	The temperature inside the inverter is higher than the permissible range.	<ol style="list-style-type: none"> 1. Make sure that the installation complies with the instructions from User Manual. 2. Check whether the alarm "Fan Fault" occurs. If so, replace the faulty fan. 3. If the alarm persists, contact Hoymiles technical support team.
Isolation Fault	The insulation impedance of the PV string to the ground is too low.	<ol style="list-style-type: none"> 1. Use a multimeter to determine if the resistance between the earth and the inverter frame is close to zero. If not, please ensure that the connection is good. 2. If the humidity is too high, an isolation fault may occur. Attempt to restart the inverter. If the fault persists, check it again when the weather turns fine. 3. Check the resistance to ground from the PV module/ cable. Take corrective measures in case of leading to a short circuit or damaged insulation layer. 4. If the alarm persists, contact Hoymiles technical support team.
Arc Fault	The inverter detects that there is an arc fault.	<ol style="list-style-type: none"> 1. Disconnect the DC switch and check whether DC cables are damaged and whether the wiring terminals are loose or in poor contact. If so, take corresponding corrective measures. 2. After taking corresponding measures, turn on the DC switch. 3. If the alarm persists, contact Hoymiles technical support team.
EPS Load Overpower	The EPS load power is higher than the permissible range.	<ol style="list-style-type: none"> 1. Reduce the power of EPS loads, or remove some EPS loads. The inverter will restart automatically. 2. If the alarm persists, contact Hoymiles technical support team.
Meter Reverse Connection	The inverter detects that the Meter or CT is reversely connected.	<ol style="list-style-type: none"> 1. Make sure that the installation complies with the instructions from User Manual. 2. If the alarm persists, contact Hoymiles technical support team.
Meter Communication Fault	The inverter detects that there is a meter communication fault.	<ol style="list-style-type: none"> 1. Check whether the Meter communication cable and terminal are abnormal. 2. Reconnect the Meter communication cable. 3. If the alarm persists, contact Hoymiles technical support team.
Battery Reverse Connection	The inverter detects that the battery wirings are reversely connected.	<ol style="list-style-type: none"> 1. Check the battery for polarity correctness, and correct it if necessary. 2. If the alarm persists, contact Hoymiles technical support team.
Battery Voltage Fault	The battery voltage is higher than the permissible range.	<ol style="list-style-type: none"> 1. Check if the battery input voltage is within the normal range. 2. If the alarm persists, contact Hoymiles technical support team.
BMS Communication Fault	The inverter detects that there is a BMS communication fault.	<ol style="list-style-type: none"> 1. Check whether the BMS communication cable and terminal are abnormal. 2. Reconnect the BMS communication cable. 3. If the alarm persists, contact Hoymiles technical support team.

Display	Possible Cause	Handling Suggestions
BMS Battery Alarm	The inverter detects that there is a battery fault from BMS.	Try to restart the battery. If the fault persists, contact the battery manufacturer.
BMS Battery Fault	The inverter detects that there is a battery fault from BMS.	Try to restart the battery. If the fault persists, contact the battery manufacturer.
Relay Fault	The inverter detects that there is a relay self-check fault.	Try to restart the inverter. If the fault persists, contact Hoymiles technical support team.

5. Technical Datasheet

Model	HYS-3.8LV-USG1	HYS-4.8LV-USG1	HYS-6.0LV-USG1	HYS-7.6LV-USG1	HYS-9.6LV-USG1	HYS-11.5LV-USG1
Battery						
Battery Type	Li-ion / Lead-acid					
Nominal Battery Voltage (V)	48					
Voltage Range (V)	40-60					
Max. Charge Current (A)	80	100	100	160	200	200
Max. Discharge Current (A)	80	100	100	160	200	200
Charging Strategy for Li-ion Battery	Self-adaption to BMS					
Charging Curve	3 Stages / Equalization					
External Temperature Sensor	Optional					
PV Input						
Max. PV Input Power (W)	5760	7200	9000	11520	14400	14400
Max. PV Input Voltage (V)	550					
Nominal Input Voltage (V)	380					
MPPT Voltage Range (V)	125-500					
Start-up Voltage (V)	150					
Number of MPPTs	2	2	2	2	2	2
Max. Number of PV String per MPPT	1/1	1/1	1/1	2/2	2/2	2/2
Max. PV Input Current (A)	16/16	16/16	16/16	32/32	32/32	32/32
Short-circuit Current of PV Input (A)	20/20	20/20	20/20	40/40	40/40	40/40
AC Input and Output (On-grid)						
Nominal Output Apparent Power (VA)	3840	4800	6000	7680	9600	11520
Max. Output Apparent Power (VA)	3840	4800	6000	7680	9600	11520
Max. Input Apparent Power (VA)	7680	9600	12000	15360	19200	19200
Nominal AC Voltage (V)	240					
Nominal Grid Frequency (Hz)	60					
Max. Output Current (A)	16	20	25	32	40	48
Max. Input Current (A)	32	40	50	64	80	80
Power Factor	0.8 leading ... 0.8 lagging					
Total Harmonic Distortion (@nominal output)	< 3%					
AC Output (Off-grid)						
Max. Output Apparent Power (VA)	3840	4800	6000	7680	9600	9600
Peak Output Apparent Power (VA) ⁽¹⁾	7680, 10s	9600, 10s	12000, 10s	15360, 10s	19200, 10s	19200, 10s
Nominal AC Voltage (V)	120 / 240 (split phase)					
Nominal AC Frequency (Hz)	60					
Max. Continuous Output Current (A)	16	20	25	32	40	40
Total Harmonic Distortion (@ linear load)	< 3%					
Efficiency						
Max. Efficiency	97.6%	97.6%	97.6%	97.6%	97.6%	97.6%
CEC Efficiency	97.0%	97.0%	97.0%	97.0%	97.0%	97.0%
Max. Battery to Load Efficiency	95.0%	95.0%	95.0%	95.0%	95.0%	95.0%
MPPT Efficiency	99.9%	99.9%	99.9%	99.9%	99.9%	99.9%
Protection						
Anti-islanding Protection	Integrated					
PV Arc Fault Detection	Integrated					
PV String Input Reverse Polarity Protection	Integrated					
Compliant MLRSD Products	Integrated					
Insulation Resistor Detection	Integrated					
Residual Current Monitoring Unit	Integrated					
AC Over Current Protection	Integrated					
AC Short Current Protection	Integrated					
AC Overvoltage and Undervoltage Protection	Integrated					
General						
Dimension (W × H × D)	19.8 × 24.2 × 7.95 inch (502 × 615 × 202 mm)			19.8 × 29.1 × 7.95 inch (502 × 740 × 202 mm)		
Weight	68.3 lbs (31 kg)			90.4 lbs (41 kg)		
Mounting	Wall Mounting					
Operation Temperature (°F)	-13 to +149 (> 113, derating)					
Relative Humidity	0-95%, no condensing					
Altitude (m)	≤ 2000					
Cooling	Natural convection					
Protection Degree	Type 4X					
Noise (dB [A])	< 40					
User Interface	LED & App					
Communication with BMS	RS485, CAN					
Communication with Meter	RS485					
Communication Interface	RS485, Wi-Fi/Ethernet/4G (optional)					
Digital Input / Output	1 × DI, 2 × DO					
Max. Parallel	10					
Isolation Method (Solar / Battery)	Transformerless / High-frequency Isolation					
Warranty	10 years					
Certifications and Standards						
Grid Regulation	IEEE 1547-2018, IEEE 1547.1-2020, SRD2.0					
Safety Regulation	UL 1741, CSA C22.2 No.107.1, UL 1741 CRD, UL 1741 SB					
AFCI	UL 1699B					
Software Approval	UL 1998					
EMC	FCC Part 15 Class B					

(1) Can be achieved only if PV and battery power are sufficient.



S-Miles Installer

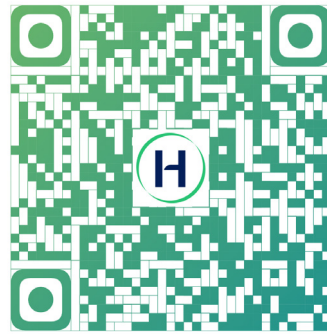

S-Miles End-user

Floor 6-10, Building 5, 99 Housheng Road, Gongshu District,
Hangzhou 310015
P. R. China
+86 571 2805 6101

General inquiry: info@hoymiles.com
Technical support: service@hoymiles.com

Visit <https://www.hoymiles.com/> for more informations.