

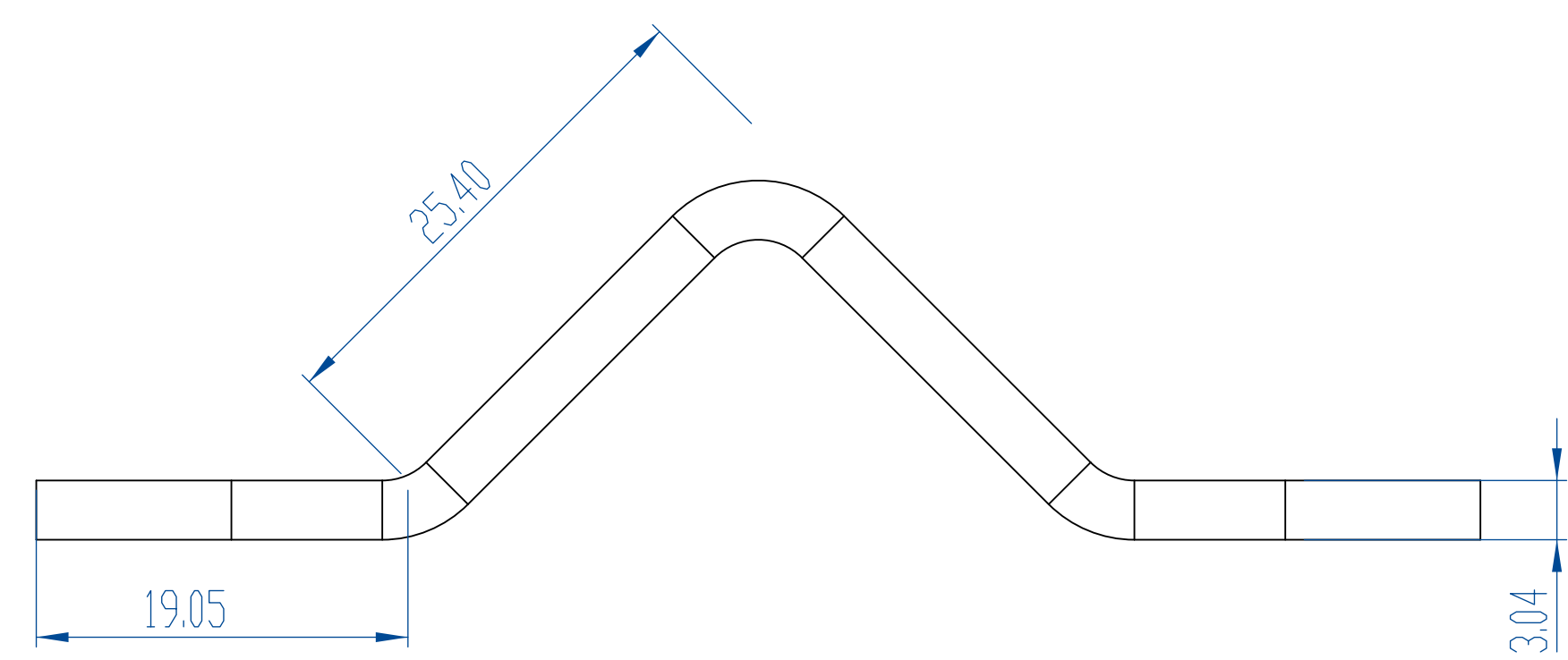

SOPORTE UNIVERSAL PTZ
1 PZ

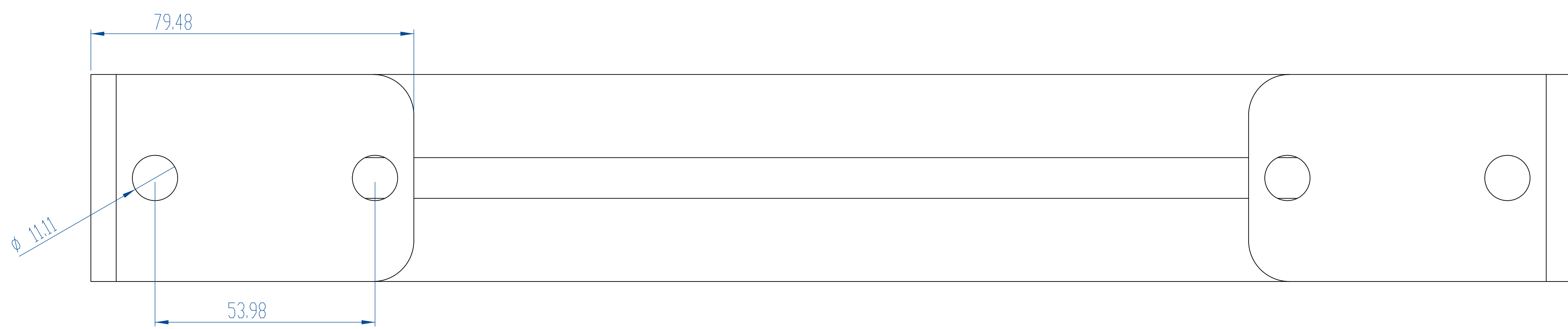

CONTRA SOPORTE
2PZ

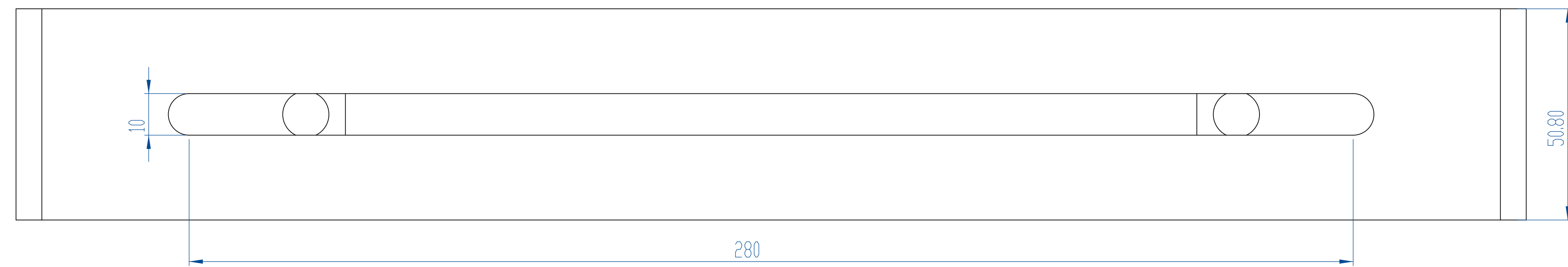
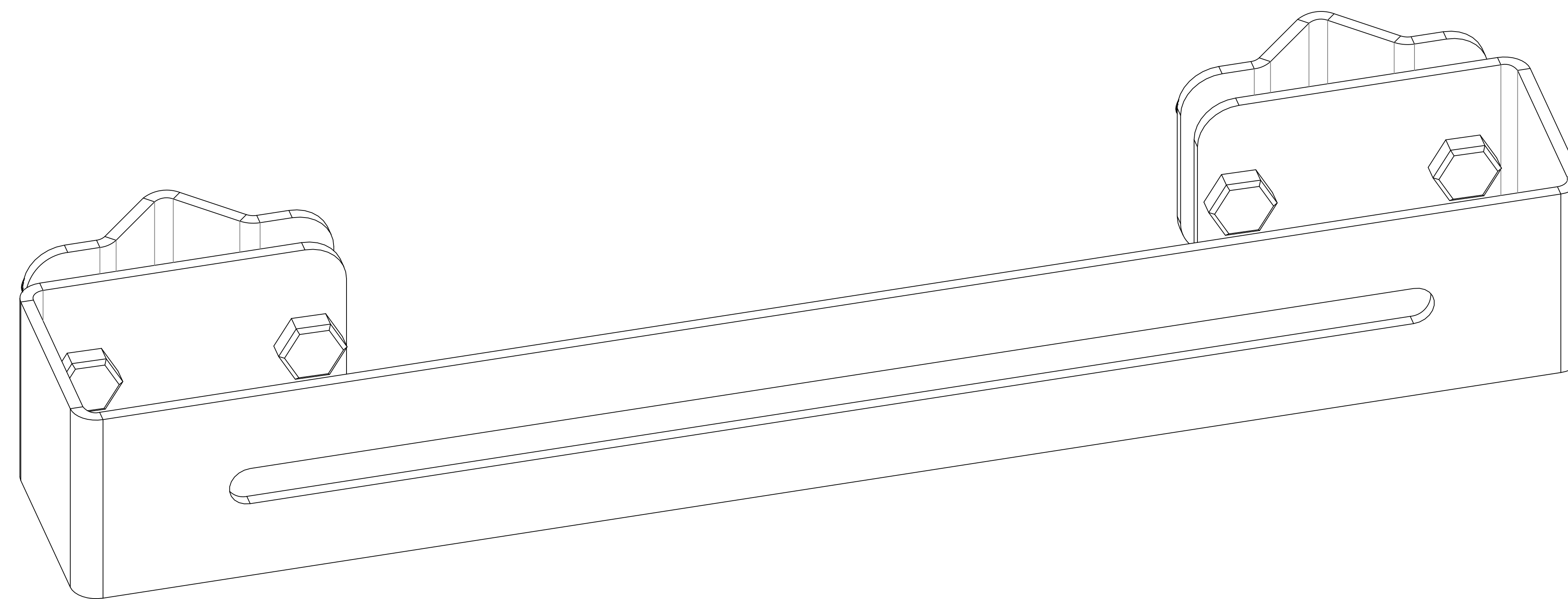
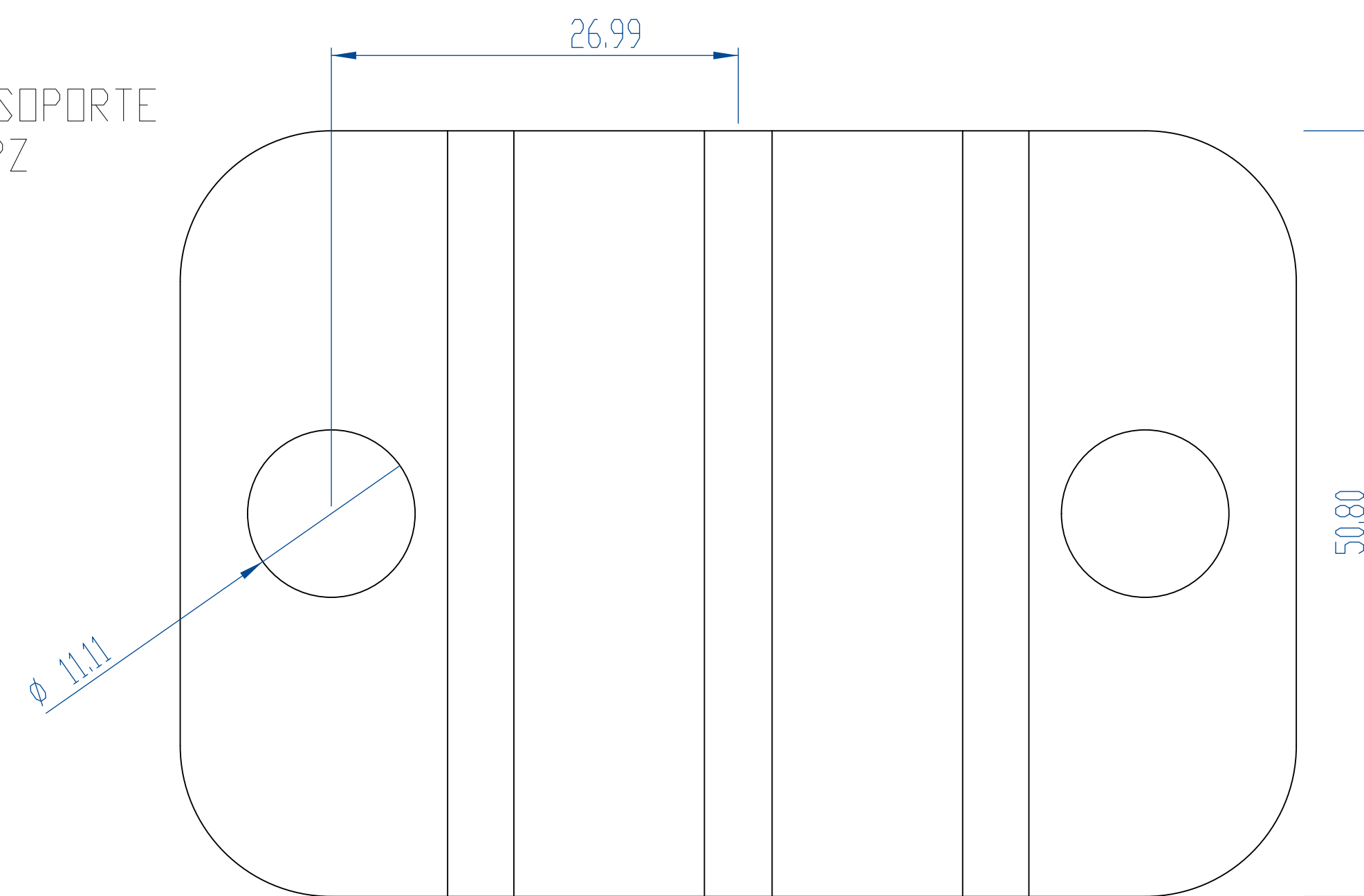

SOPORTE UNIVERSAL PTZ
1 PZ

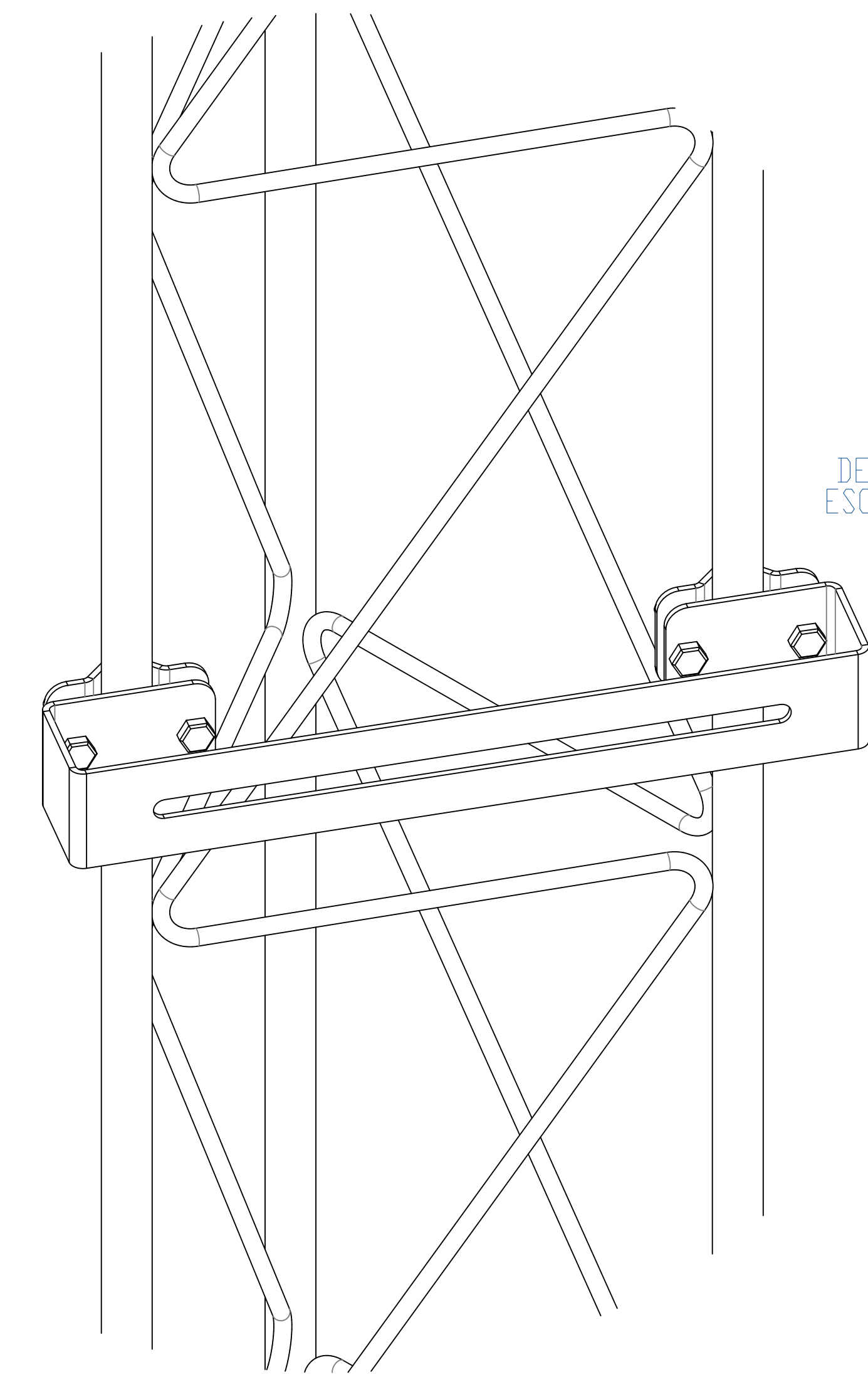

DETALLE B
ESCALA 1 : 3

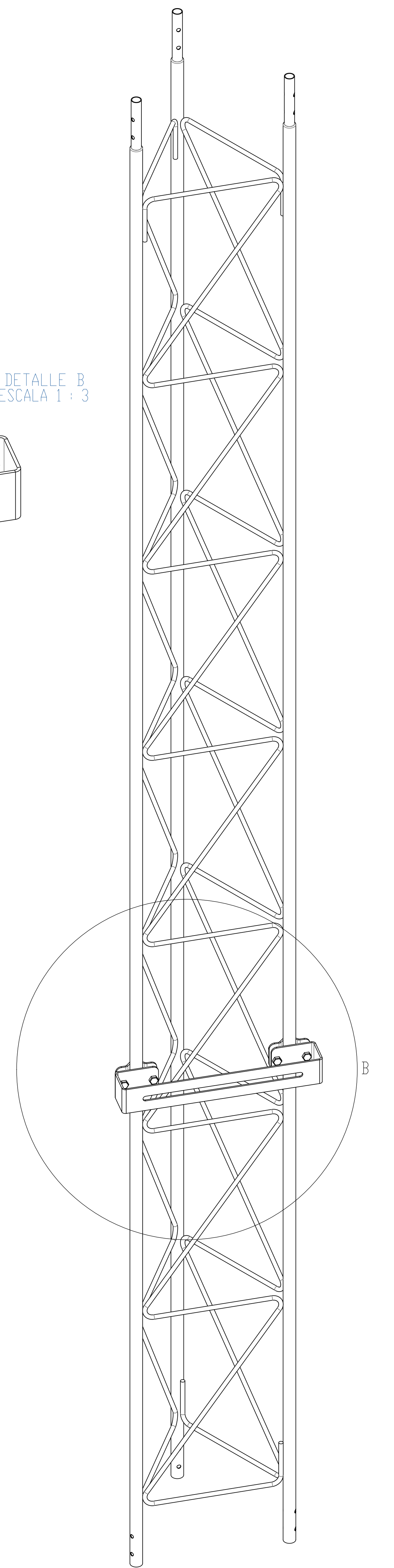

ACABADO	NOTAS GENERALES	NOMBRE	DESCRIPCION PRODUCTO	
* GALVANIZADO POR INMERSION EN CALIENTE	1. MEDIDAS EN MILIMETROS, EXCEPTO INDICADAS. 2. TOLERANCIA GENERAL ± 1 mm. 3. TODO MATERIAL ES DE ACERO ASTM - 36. 4. TODA LA SOLDADURA SERA DEL TIPO AWS E7018. 5. LA TORILLERA ES GRADO MAQUINA Y/O INOXIDABLE.	DIBUJO: Joarria Molina	SOPORTE UNIVERSAL PTZ	
* GALVANIZADO ELECTROLITICO		REVISO: Daniel Corredón		
* PINTURA ADVANCE 400 DTM		APROBO: Daniel Corredón		
TODA LA INFORMACION EMITIDA EN ESTE PLANO ES PROPIEDAD DE SYSKOM. QUEDA PROHIBIDA SU REPRODUCCION PARCIAL O TOTAL.		EMISION: 22 NOVIEMBRE 2018		
		NOMBRE PLANO: HUPTZ		REVISION: REV. 001