

# Grandstream Networks, Inc.

---

GAC2500 Audio Conference Phone for Android™

User Guide



# GAC2500 User Guide

## Index

CHANGE LOG .....	9
FIRMWARE VERSION 1.0.1.18 .....	9
FIRMWARE VERSION 1.0.1.6 .....	9
WELCOME.....	10
PRODUCT OVERVIEW .....	12
FEATURE HIGHLIGHTS .....	12
SAFETY COMPLIANCES.....	13
WARRANTY.....	13
INSTALLING GAC2500.....	14
EQUIPMENT PACKAGE CONTENT .....	14
PRODUCT APPEARANCE.....	14
CONNECTING GAC2500 .....	15
IP MODE.....	16
USB SLAVE MODE .....	17
CASCADE MODE.....	17
MOBILE PHONE MODE .....	18
GETTING TO KNOW GAC2500 .....	20
DESKTOP .....	20
STATUS ICONS .....	20
USING THE ONSCREEN KEYBOARD.....	21
ENGLISH KEYBOARD .....	21
CHINESE KEYBOARD.....	22
NUMBERS AND SYMBOLS.....	22
USING THE LED INDICATOR.....	23
ASSISTIVE TOUCH.....	24
USING TOUCHSCREEN.....	24
SHORTCUT KEYS.....	25
MANAGING STATUS BAR .....	25
DESKTOP MENU .....	26
EDIT WALLPAPER.....	26
EDIT DESKTOP.....	27
ADDING AN ITEM TO DESKTOP .....	27
MANAGING DESKTOP APPS AND ITEMS .....	28
OPENING AN APP .....	28
MOVING AN APP .....	28
REMOVING AN APP .....	29
MANAGING APPLICATIONS.....	29

HOME SCREEN .....	30
CONNECTING TO NETWORK AND DEVICES .....	32
NETWORK.....	32
ETHERNET .....	32
WI-FI .....	32
TURNING WI-FI ON OR OFF .....	33
BLUETOOTH .....	33
TURNING BLUETOOTH ON OR OFF .....	33
PAIRING GAC2500 WITH A BLUETOOTH DEVICE.....	33
CONNECTING TO A BLUETOOTH DEVICE .....	34
SENDING FILES VIA BLUETOOTH.....	35
VPN SETTINGS.....	35
VLAN SETTINGS.....	37
LLDP SETTINGS .....	37
802.1X MODE .....	37
MAKING PHONE CALLS .....	39
ACCOUNT .....	39
MAKING A CALL.....	39
DIRECT DIALING .....	39
REDIAL.....	40
DIALING A NUMBER VIA CONTACT.....	40
DIALING A NUMBER VIA CALL HISTORY .....	40
DIRECT IP CALL.....	40
PAGING/INTERCOM.....	41
ANSWERING A CALL.....	41
REJECT CALL VIA SMS .....	42
CALL MANAGEMENT .....	42
CALL HOLD AND CALL RESUME .....	43
CALL RECORD .....	44
MUTE .....	45
CALL TRANSFER.....	45
BLIND TRANSFER.....	45
ATTENDED TRANSFER .....	46
DND (DO NOT DISTURB) .....	48
MISSED CALL .....	49
CALL FORWARD.....	49
SET ON LCD .....	49
SET FROM WEB GUI.....	50
7-WAY CONFERENCE.....	50
INITIATING CONFERENCE .....	50
CONFERENCE MANAGEMENT.....	52

INVITE MEMBERS TO CONFERENCE .....	53
REMOVING MEMBER FROM CONFERENCE .....	54
THIRD PARTY APPLICATIONS .....	54
END CONFERENCE .....	54
SCHEDULE CONFERENCE .....	54
VIEW CONFERENCE DETAILS .....	55
ADD SCHEDULED CONFERENCE.....	55
EDIT SCHEDULED CONFERENCE .....	57
RESCHEDULE CONFERENCE .....	57
DELETE SCHEDULED CONFERENCE .....	57
DELETE HISTORY CONFERENCE.....	58
VOICEMAIL .....	59
APPLICATIONS .....	61
CONTACTS.....	61
LOCAL CONTACTS.....	61
ADD CONTACT .....	62
SEARCH CONTACTS.....	65
MANAGE CONTACTS .....	65
GROUPS .....	68
ADD NEW GROUP .....	68
CALL GROUPS .....	69
DELETE GROUP .....	70
BLACKLIST .....	70
LDAP .....	72
CALL HISTORY .....	75
ADD CONTACT FROM CALL HISTORY.....	76
DELETE CALL HISTORY .....	76
SCHEDULE CONFERENCE VIA CALL HISTORY .....	76
INTERCEPTED HISTORY .....	77
MPK .....	78
EVENR LIST URL.....	79
MPK SETTINGS .....	80
NOTICES .....	81
VIEW NOTICES.....	81
DELETE NOTICES.....	81
NOTICES SETTINGS.....	82
FILE MANAGER .....	82
COPY FILE .....	83
SEND FILE .....	83
DELETE FILE .....	83
RENAME FILE.....	83

RECORDER .....	84
NORMAL RECORDER .....	84
CALL RECORDER .....	85
RECORDER SETTINGS .....	85
DIAGNOSIS .....	86
BROWSER .....	86
GS MARKET .....	87
SEARCH APPS.....	87
DOWNLOAD AND INSTALL APPS.....	87
UPDATE APPS .....	87
GAC2500 WEB UI FEATURES.....	88
ACCESSING GAC2500 WEB GUI .....	88
SAVING CHANGES .....	88
DEFINITIONS .....	89
CALL PAGE .....	90
MAKING A CALL.....	90
SINGLE INCOMING CALL .....	91
CONFERENCE CONTROL.....	91
CONTACTS PAGE.....	92
CONTACTS .....	92
CONTACTS .....	92
GROUPS .....	94
BLACKLIST .....	94
SCHEDULE .....	95
UPCOMING CONFERENCE .....	95
HISTORY CONFERENCE .....	95
CALL HISTORY .....	96
LDAP .....	97
EXPERIENCING GAC2500 .....	98

**Table of Tables**  
**GAC2500 User Guide**

Table 1 GAC2500 Technical Specifications.....	12
Table 2 GAC2500 Package List .....	14
Table 3 GAC2500 Interfaces Explanations .....	15
Table 4 GAC2500 Status Icons Descriptions .....	20
Table 5 GAC2500 LED Indicator Descriptions .....	23
Table 6 GAC2500 VPN File Parameters.....	36
Table 7 GAC2500 VLAN Configuration Parameters .....	37
Table 8 GAC2500 LLDP Configuration Parameters.....	37
Table 9 GAC2500 802.1X Mode Parameters.....	38
Table 10 GAC2500 Import Contacts Parameters.....	64
Table 11 GAC2500 Download Contacts Parameters .....	65
Table 12 GAC2500 Export Contacts Parameters .....	66
Table 13 GAC2500 Blacklist Settings Parameters.....	71
Table 14 GAC2500 LDAP Book Parameters .....	73
Table 15 GAC2500 MPK Settings Parameters .....	80
Table 16 GAC2500 Users Access Permissions .....	89

## Table of Figures

### GAC2500 User Guide

Figure 1 GAC2500 Host Interfaces.....	14
Figure 2 GAC2500 Connection Mode.....	16
Figure 3 GAC2500 Slave Mode Screen.....	17
Figure 4 GAC2500 Cascade Mode Screen.....	18
Figure 5 GAC2500 Select line Sequence Screen.....	19
Figure 6 GAC2500 Multi-screens.....	20
Figure 7 GAC2500 Soft Keyboard - English Input Method.....	22
Figure 8 GAC2500 English Keyboard - Uppercase.....	22
Figure 9 GAC2500 Chinese Keyboard - Google Pinyin Method.....	22
Figure 10 GAC2500 Soft Keyboard - Symbols and Numbers.....	22
Figure 11 GAC2500 Soft Keyboard - More Symbols and Numbers.....	23
Figure 12 GAC2500 Finger Gestures.....	24
Figure 13 GAC2500 Status Bar - Notifications.....	25
Figure 14 GAC2500 Idle Screen Menu.....	26
Figure 15 GAC2500 Choose Wallpaper.....	26
Figure 16 GAC2500 Edit Desktop.....	27
Figure 17 GAC2500 Weather Forecast Screen.....	28
Figure 18 GAC2500 Move Weather Forecast to Desktop.....	29
Figure 19 GAC2500 Remove Weather Forecast from Desktop.....	29
Figure 20 GAC2500 Managing Applications.....	30
Figure 21 GAC2500 Home Screen.....	30
Figure 22 GAC2500 Add Wi-Fi Screen.....	33
Figure 23 GAC2500 Bluetooth - Paired Device.....	34
Figure 24 GAC2500 Bluetooth - Paired Device.....	35
Figure 25 GAC2500 Add VPN Files Screen.....	36
Figure 26 GAC2500 Registered Account Status.....	39
Figure 27 GAC2500 Single Incoming Call Screen.....	41
Figure 28 GAC2500 New Incoming Call Screen.....	42
Figure 29 GAC2500 Single Incoming Call Screen.....	43
Figure 30 GAC2500 Call On Hold Screen.....	44
Figure 31 GAC2500 More - Start Recording.....	44
Figure 32 GAC2500 Mute Call Screen.....	45
Figure 33 GAC2500 Transfer - Blind Transfer.....	46
Figure 34 GAC2500 Transfer - Attended Transfer.....	47
Figure 35 GAC2500 Call Forward - Select Forward Mode.....	47
Figure 36 GAC2500 Call Forward - Transferring.....	48
Figure 37 GAC2500 Call Forward - Split.....	48
Figure 38 GAC2500 Call Forward Type Setting Screen.....	49
Figure 39 GAC2500 Call Forward Mode On Web GUI.....	50

Figure 40 GAC2500 Conference Screen .....	51
Figure 41 GAC2500 Add Party To Conference .....	51
Figure 42 GAC2500 3-Way Conference .....	52
Figure 43 GAC2500 Conference-More .....	53
Figure 44 GAC2500 Schedule Screen.....	55
Figure 45 GAC2500 Conference Details Screen .....	55
Figure 46 GAC2500 Add Conference Screen.....	56
Figure 47 GAC2500 Delete Scheduled Conference Screen .....	57
Figure 48 GAC2500 Delete History Conference Screen .....	58
Figure 49 GAC2500 Batch Delete History Conference Screen .....	59
Figure 50 GAC2500 Voice Mail Application .....	60
Figure 51 GAC2500 Contacts Screen .....	61
Figure 52 GAC2500 Local Contacts Screnn.....	62
Figure 53 GAC2500 Add New Contact Screen.....	63
Figure 54 GAC2500 Import Contacts Parameters Screen .....	63
Figure 55 GAC2500 Download Contacts Screen .....	64
Figure 56 GAC2500 Export Contacts Screen .....	66
Figure 57 GAC2500 Contacts Storage Status Screen .....	67
Figure 58 GAC2500 Add Google Account - Wizard 1 .....	67
Figure 59 GAC2500 Add Google Account - Wizard 2.....	68
Figure 60 GAC2500 Groups Screen.....	68
Figure 61 GAC2500 Add Group Screen .....	69
Figure 62 GAC2500 Dial Group Members Screen .....	69
Figure 63 GAC2500 Edit Groups Screen.....	70
Figure 64 GAC2500 Blacklist Screen .....	70
Figure 65 GAC2500 Manual Add Blacklist Screen .....	71
Figure 66 GAC2500 Blacklist Settings Screen .....	71
Figure 67 GAC2500 LDAP Book Screen .....	72
Figure 68 GAC2500 LDAP Settings.....	72
Figure 69 GAC2500 Web GUI Maintenance - LDAP Book.....	74
Figure 70 GAC2500 Add LDAP Contact To Local.....	74
Figure 71 GAC2500 Call History Screen .....	75
Figure 72 GAC2500 Call History Details.....	75
Figure 73 GAC2500 Add Contact screen.....	76
Figure 74 GAC2500 Conference Call History Screen .....	77
Figure 75 GAC2500 Intercepted History Screen .....	77
Figure 76 GAC2500 Add MPK Number .....	78
Figure 77 GAC2500 MPK Number List.....	78
Figure 78 GAC2500 Add Number from Contacts.....	79
Figure 79 GAC2500 MPK Number Screen .....	79
Figure 80 GAC2500 MPK Number Screen .....	80



Figure 81 GAC2500 MPK Settings Screen .....	80
Figure 82 GAC2500 Notices Screen.....	81
Figure 83 GAC2500 View Notices .....	81
Figure 84 GAC2500 Notices Setting Screen .....	82
Figure 85 GAC2500 Incoming Call Screen.....	82
Figure 86 GAC2500 Normal Recorder.....	84
Figure 87 GAC2500 Normal Record-Recording .....	85
Figure 88 GAC2500 Call Recordings.....	85
Figure 89 GAC2500 Recorder Settings Screen.....	86
Figure 90 GAC2500 Web GUI - Login .....	88
Figure 91 GAC2500 Web UI Tool Bar .....	89
Figure 92 GAC2500 Web UI - Call.....	90
Figure 93 GAC2500 Web UI - Single Incoming Call .....	91
Figure 94 GAC2500 Web UI - Minimize Call Screen .....	91
Figure 95 GAC2500 Web UI - Conference Control.....	92
Figure 96 GAC2500 Web UI - Minimize Conference Screen .....	92
Figure 97 GAC2500 Web UI - Contacts.....	93
Figure 98 GAC2500 Web UI – Groups .....	94
Figure 99 GAC2500 Web Page - Blacklist.....	94
Figure 100 GAC2500 Web Page - Upcoming Conference .....	95
Figure 101 GAC2500 Web Page - History Conference .....	96
Figure 102 GAC2500 Web UI - Call History .....	96

## CHANGE LOG

This section documents significant changes from previous versions of GAC2500 user manuals. Only major new features or major document updates are listed here. Minor updates for corrections or editing are not documented here.

### FIRMWARE VERSION 1.0.1.18

- Increase call history to 2000 entries
- Update the screenshots
- Add cycle conference
- Update the chapter of third party application

### FIRMWARE VERSION 1.0.1.6

- This is the initial version.

## WELCOME

Thank you for purchasing Grandstream GAC2500 Audio Conference Phone for Android™. This User Guide describes the basic concept and tasks necessary to use and configure your GAC2500. This document covers the topics of conference environment setups, start conference and the relevant operations like conference reservation. To learn the advanced features and configurations, please visit <http://www.grandstream.com> to download the latest "GAC2500 Administration Guide".

GAC2500 is a next generation enterprise-grade 6-line Android IP conference phone with a 4.3" capacitive touch screen that runs the Android Operating System and therefore offers full access to the hundreds of thousands of Android apps in the Google Play Store, including business productivity apps such as Skype™, Skype for Business™, and Google Hangouts™. The phone features Gigabit ports, 7-way conference, 3x microphones, 1 Micro USB port, integrated WiFi and Bluetooth for network flexibility. The GAC2500 delivers superior HD audio quality, rich and leading edge telephony features, automated provisioning for easy deployment, advanced security protection for privacy, and broad interoperability with most 3<sup>rd</sup> party SIP devices and leading SIP/NGN/IMS platforms. GAC2500 is a perfect choice for enterprise users looking for a high performance, feature rich conference phone with superb audio quality at competitive price.

---

 **Caution:**

Changes or modifications to this product not expressly approved by Grandstream, or operation of this product in any way other than as detailed by this User Manual, could void your manufacturer warranty.

---

 **Warning:**

Please do not use a different power adaptor with the GAC2500 as it may cause damage to the products and void the manufacturer warranty.

---

This document is subject to change without notice. The latest electronic version of this user manual is available for download here:

<http://www.grandstream.com/support>

Reproduction or transmittal of the entire or any part, in any form or by any means, electronic or print, for any purpose without the express written permission of Grandstream Networks, Inc. is not permitted.

---

 **FCC Caution:**

Any Changes or modifications not expressly approved by the party responsible for compliance could void the user's authority to operate the equipment. This device complies with part 15 of the FCC Rules. Operation is subject to the following two conditions: (1) This device may not cause harmful interference, and (2) this device must accept any interference received, including interference that may cause undesired operation.

Note: This equipment has been tested and found to comply with the limits for a Class B digital device, pursuant to part 15 of the FCC Rules. These limits are designed to provide reasonable protection against harmful interference in a residential installation. This equipment generates uses and can radiate radio frequency energy and, if not installed and used in accordance with the instructions, may cause harmful

---

interference to radio communications. However, there is no guarantee that interference will not occur in a particular installation. If this equipment does cause harmful interference to radio or television reception, which can be determined by turning the equipment off and on, the user is encouraged to try to correct the interference by one or more of the following measures:

- Reorient or relocate the receiving antenna.
- Increase the separation between the equipment and receiver.
- Connect the equipment into an outlet on a circuit different from that to which the receiver is connected.
- Consult the dealer or an experienced radio/TV technician for help.

This transmitter must not be co-located or operating in conjunction with any other antenna or transmitter. For operation within 5.15 ~ 5.25GHz / 5.47 ~5.725GHz frequency range, it is restricted to indoor environment. The band from 5600-5650MHz will be disabled by the software during the manufacturing and cannot be changed by the end user. This device meets all the other requirements specified in Part 15E, Section 15.407 of the FCC Rules.

Radiation Exposure Statement:

This equipment complies with FCC radiation exposure limits set forth for an uncontrolled environment. This equipment should be installed and operated with minimum distance 20cm between the radiator & your body.

---

## PRODUCT OVERVIEW

### FEATURE HIGHLIGHTS

- Runs Android™ 4.4 and offers full access to all Android™ conference apps in the Google Play Store (e.g., Skype™, Skype for Business™, Google Hangouts™, etc.)
- World-class high fidelity sound quality with audio bandwidth of up to 18Khz
- 4.3" capacitive touch screen LCD with support for flexible layout/content customization
- 3x microphones (12 ft. pickup range), 1x speaker (15 ft. coverage range)
- Auto-sensing Gigabit Ethernet port, Wi-Fi, PoE+, Bluetooth, Micro-USB with 3.5mm audio interface
- Supports standalone IP mode or USB slave mode
- Supports daisy chain (up to 2 units via RJ48 CAT5) mode in large conference room for better audio quality
- NAT-T enables the phone being the Plug and Play device
- Automated provisioning using TR-069 or AES encrypted XML configuration file, TLS/SRTP/HTTPS for advanced security and privacy protection

**Table 1 GAC2500 Technical Specifications**

Specification	Description
<b>Protocols/ Standards</b>	SIP RFC3261, TCP/IP/UDP, RTP/RTCP, HTTP/HTTPS, ARP, ICMP, DNS (A record, SRV, NAPTR), DHCP, PPPoE, SSH, TFTP, NTP, STUN, SIMPLE, LLDP, LDAP, TR-069, 802.1x, TLS, SRTP, IPv6 (pending), OpenVPN (pending)
<b>Voice Codec</b>	Support for G.711μ/a, G.722, G.726, iLBC, Opus, G.722.1, G.722.1c (pending), in-band and out-of-band DTMF (In audio, RFC2833, SIP INFO)
<b>Platform Bridging</b>	Bridge SIP calls with any Android™ VoIP apps such as Skype™, Skype for Business (Lync), Google Hangouts™ and more
<b>Telephony Features</b>	Hold, transfer, forward (unconditional/no-answer/busy/conditional), call park/pickup, 7-way audio conference, auto answer, downloadable XML phone book (up to 2000 entries), LDAP, call waiting, call history (up to 2000 entries), flexible dial plan, personalized music ringtones, server redundancy & fail-over
<b>Sample Applications</b>	Skype™, Google Hangouts™, Skype for Business (Lync), Web browser, Facebook™, Twitter™, YouTube, Google calendar, mobile phone data import/export via Bluetooth, etc. API/SDK available for advanced custom application development
<b>Application Deployment</b>	Allows Android 4.4 compliant applications to be deployed in the device with provisioning control
<b>QoS</b>	Layer 2 QoS (802.1Q, 802.1p) and Layer 3 (ToS, DiffServ, MPLS) QoS
<b>Security</b>	User and administrator level passwords, MD5 and MD5-sess based authentication, 256-bit AES encrypted configuration file, TLS, 128/256-bit SRTP/TLS, HTTPS, 802.1x media access control

<b>Multi-Language</b>	English, German, Italian, French, Spanish, Portuguese, Russian, Turkish, Polish, Chinese, Korean, Japanese, and more
<b>Upgrade/ Provisioning</b>	Firmware upgrade via TFTP / HTTP / HTTPS or local HTTP upload, mass provisioning using TR-069 or AES encrypted XML configuration file
<b>Network Interface</b>	1x auto-sensing Gigabit Ethernet port, integrated 2.4GHZ auto-band Wi-Fi (802.11a/b/g/n) and 4.0 Bluetooth.
<b>HD Audio</b>	3x microphones (12 ft. pickup range), 1x speaker (220-18,000 Hz, 15 ft. coverage range up to 86dB )
<b>Auxiliary Ports</b>	3.5mm audio interface, Micro-USB interface, RJ48 interface, reset pin
<b>Graphic Display</b>	4.3" (800*480) capacitive touch screen LCD
<b>Power &amp; Green Energy Efficiency</b>	Universal power adapter included: Input: 100-240VAC 50-60Hz; Output: 12VDC, 2A (24W)
<b>Temperature and Humidity</b>	Operating: 32 - 104°F / 0 - 40°C Storage: 14 - 140°F / -10 - 60°C Humidity: 10% to 90% Non-condensing
<b>Compliance</b>	FCC: Part 15 (CFR 47) Class B; UL 60950 (power adapter) CE: EN55022 Class B, EN55024, EN61000-3-2, EN61000-3-3, EN60950-1, EN62479, RoHS RCM: AS/ACIF S004; AS/NZS CISPR22/24; AS/NZS 60950; AS/NZS 4268

## SAFETY COMPLIANCES

The GAC2500 complies with FCC/CE, RCM and various safety standards. The GAC2500 power adapter is compliant with the UL standard. Use the universal power adapter provided with the GAC2500 package only. The manufacturer's warranty does not cover damages to the phone caused by unsupported power adapters.

## WARRANTY

If the GAC2500 phone is purchased from a reseller, please contact the company where the device is purchased for replacement, repair or refund. If the phone is purchased directly from Grandstream, please contact Grandstream Support for a RMA (Return Materials Authorization) number before the product is returned. Grandstream reserves the right to remedy warranty policy without prior notification.

## INSTALLING GAC2500

### EQUIPMENT PACKAGE CONTENT

The GAC2500 package contains the following items:

Table 2 GAC2500 Package List

Name	Number
GAC2500 Main Case	1
12V Universal Power Adapter with power cable	1
Ethernet Cable	1
Micro-USB Cable	1
RJ48 CAT5	1
Quick Installation Guide	1
GPL license	1

### PRODUCT APPEARANCE

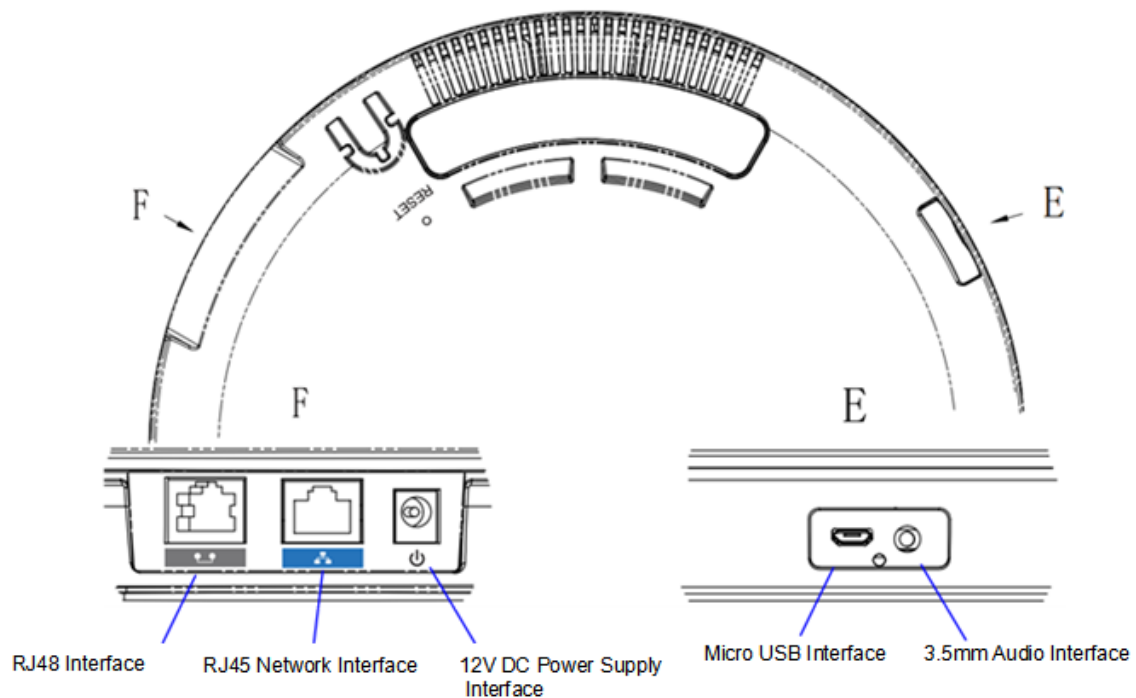

Figure 1 GAC2500 Host Interfaces

**Table 3 GAC2500 Interfaces Explanations**

NO.	Name	Explanation
①	<b>RJ48 Interface</b>	Daisy chain (up to 2 units via RJ48 CAT5) mode in large conference room for better audio quality.
②	<b>RJ45 Network Interface</b>	Connect to LAN port.
③	<b>12V DC Power Supply Interface</b>	Connect to Power Adaptor.
④	<b>Micro USB Interface</b>	USB OTG devices can be connected to GAC2500 via the USB cable. For example, connect a USB flash drive to read data, or PC USB Interface or GVC32XX SPKR Interface can be connected to the GAC2500 USB Interface via USB cable for audio pickup and play
⑤	<b>3.5mm Audio Interface</b>	Connect to 3.5mm devices like mobile phone or PC for mobile audio pickup and play
⑥	<b>Reset Pin</b>	<ul style="list-style-type: none"> <li>• When the GAC2500 is powered up, use a small pin to press the button one time to reboot.</li> <li>• When powering up GAC2500, long press the button for 4 to 9 seconds to detect whether firmware file exists in USB OTG device to update system.</li> <li>• When powering up GAC2500, long press the button for more than 10 seconds to quick restore factory settings.</li> </ul>

## CONNECTING GAC2500

To deploy a working conferencing system, users could select standalone IP mode, USB slave mode, cascade mode or mobile phone mode. Please connect the GAC2500 for each mode according to different procedures.



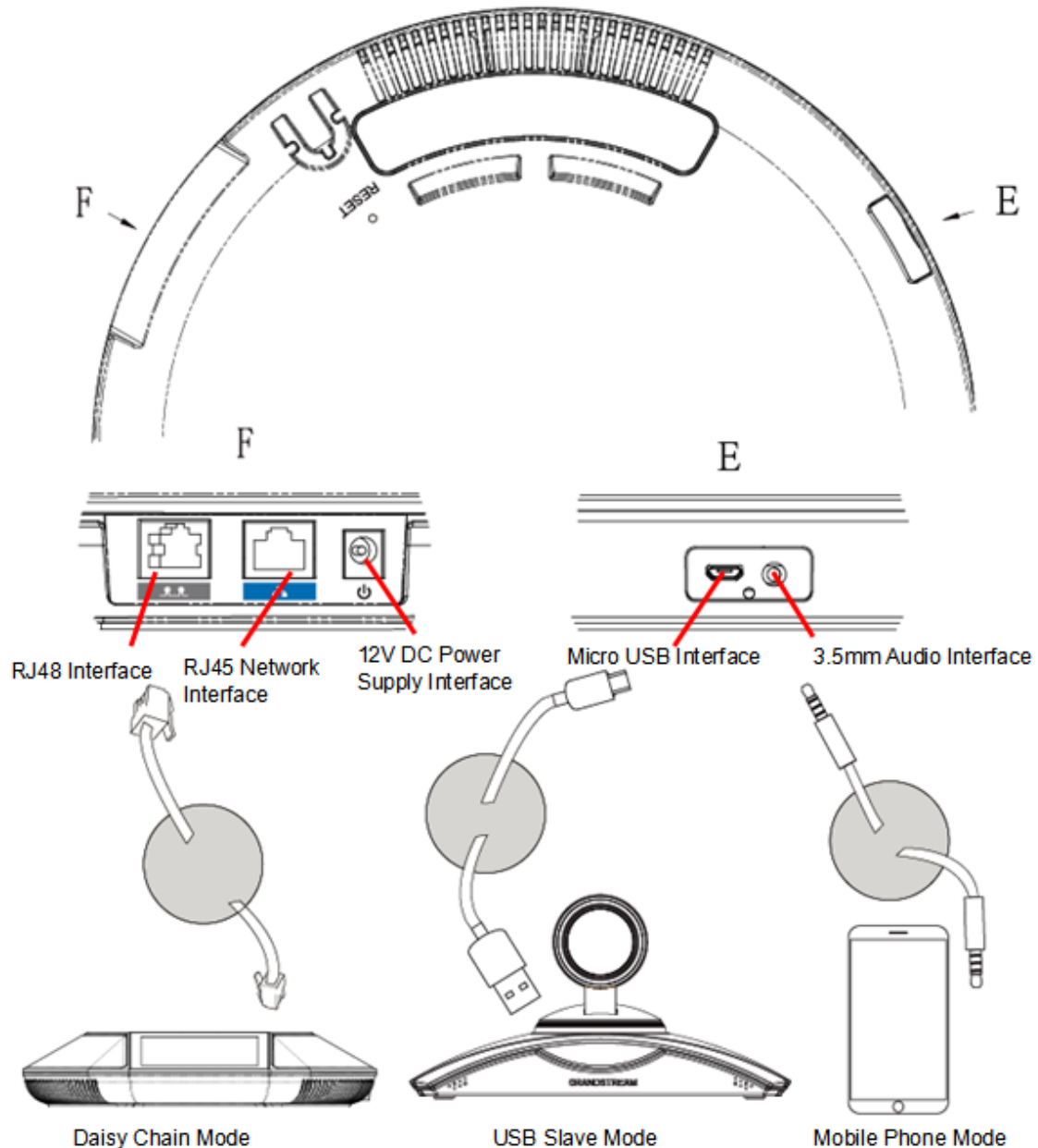

Figure 2 GAC2500 Connection Mode

## IP MODE

The GAC2500 is used as an independent phone in IP mode. Please follow the steps below to connect.

1. Connect the LAN port of the device to the external network port (the port in the office or at home) via Ethernet cable;
2. Plug in the power adapter into the power supply interface then power up the GAC2500.



**Note:**

It is recommended to use IP mode in room 3.6m\* 7.2m or smaller.

## USB SLAVE MODE

GAC2500 can be used as auxiliary device for GVC3200 or PC for audio acquisition and play. The conference feature will be disabled in USB slave mode. Follow the steps below to connect route.

1. Connect one end of the USB cable to the Micro USB port of the device and the other end to the USB port of GVC3200/PC;
2. Plug in the power adapter into the power supply interface then power up the GAC2500.

The GAC2500 screen is as shown below in USB slave mode, you can tap on the volume icon to adjust the volume of GVC3200/PC. When connecting to GVC3200, tap on "Mute", "Answer" or "Hangup" icons for more operations.

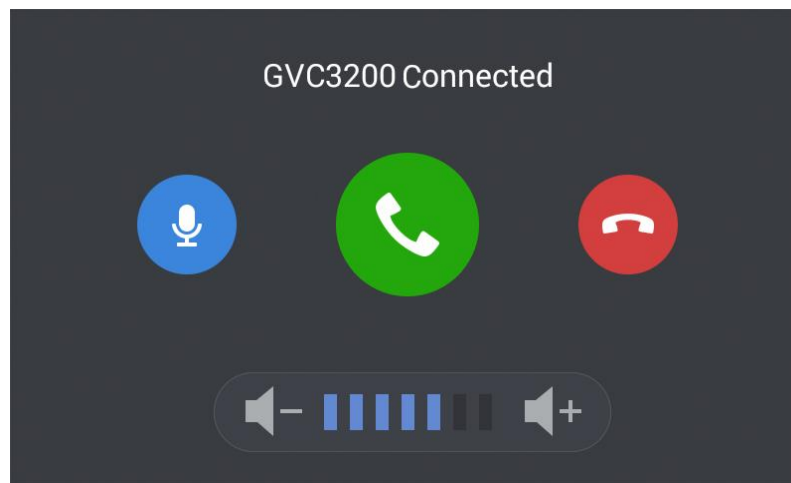

Figure 3 GAC2500 Slave Mode Screen

## CASCADE MODE

Connect two GAC2500 (s) via RJ48 CAT5 for larger space. Please follow the steps below to connect.

1. Connect the LAN port of the device to the external network port (the port in the office or at home) via Ethernet cable;
2. Connect the RJ48 ports of two devices with RJ48 CAT5;
3. Plug in two power adapters into the power supply interfaces then power up two devices;
4. The screen is as shown below. Tap on "Yes" on the first device and set it to be the master while the other the slave.



Figure 4 GAC2500 Cascade Mode Screen



Note:

1. It is recommended to use cascade mode in room 7.2m\*12.2m or smaller.
2. Please keep a distance of 5m between two devices.
3. Please make sure the master device is connected to the network or it may not work properly.
4. The slave device will synchronize with the master device and their dial screens will be shown synchronously.

## MOBILE PHONE MODE

GAC2500 could be connected to mobile phone for expanded use. Please follow the steps to connect.

1. Connect the LAN port of the device to the external network port (the port in the office or at home) via Ethernet cable;
2. Plug in the power adapter into the power supply interface then power up the GAC2500;
3. Connect one end of the via 3.5mm audio aux cable to 3.5mm headset interface on the mobile phone first, then connect the other end to 3.5mm audio interface on GAC2500, once connected, it will access 3.5mm AUX call screen;

If the audio quality is not good, it may be the line sequence issue, you can hold the screen at the top of the status bar, drag and drop down to open the status bar, tap on line sequence notifications and select the line sequence the same as the one of 3.5mm headset interface on the mobile phone.

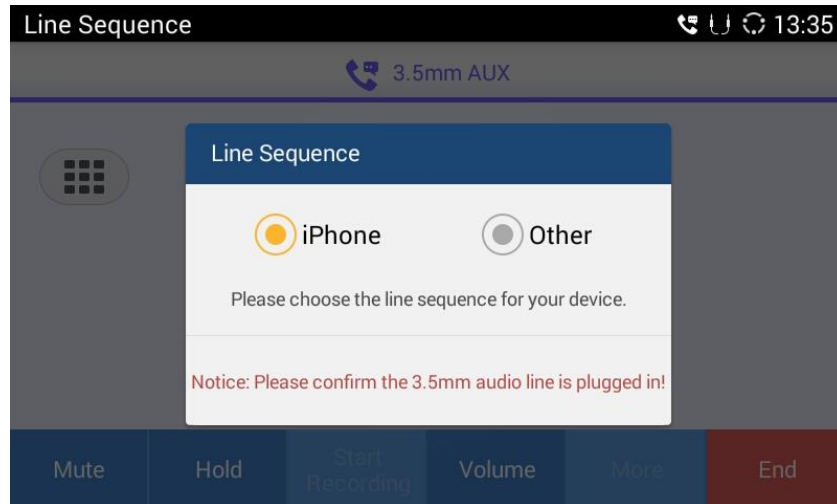

**Figure 5 GAC2500 Select line Sequence Screen**

4. When the mobile phone is answering an incoming call or dialing out, GAC2500 will collect and play the sound.



Note:

1. The GAC2500 package contains no 3.5mm audio aux cable, you can buy one at electronic gadgets store.
  2. The line sequence of GAC2500 must be the same as the one of your mobile phone, or the microphone may work improperly.
  3. It is recommended to connect mobile phone first, then GAC2500.
  4. You cannot dial or call a number via GAC2500 keypad directly.
  5. Once mobile phone mode is enabled, the 3.5mm audio aux line is regarded as one call line.
  6. Once a conference is established, the 3.5mm audio aux line is regarded as one party of the conference.
  7. Please do not unplug the 3.5mm audio aux cable or it may cause call exception.
  8. The audio quality may vary according to different types of 3.5mm audio aux cable and mobile phones.
  9. Once the 3.5mm male to male cable is inserted, some types of mobile phones may be detected by GAC2500 only after the call is established.
-

## GETTING TO KNOW GAC2500

### DESKTOP

When the GAC2500 is on idle screen, hold the screen at the bottom of the screen, drag upward to bring up 5 soft keys; hold the screen at the top of the status bar, drag and drop down to open the status bar,.

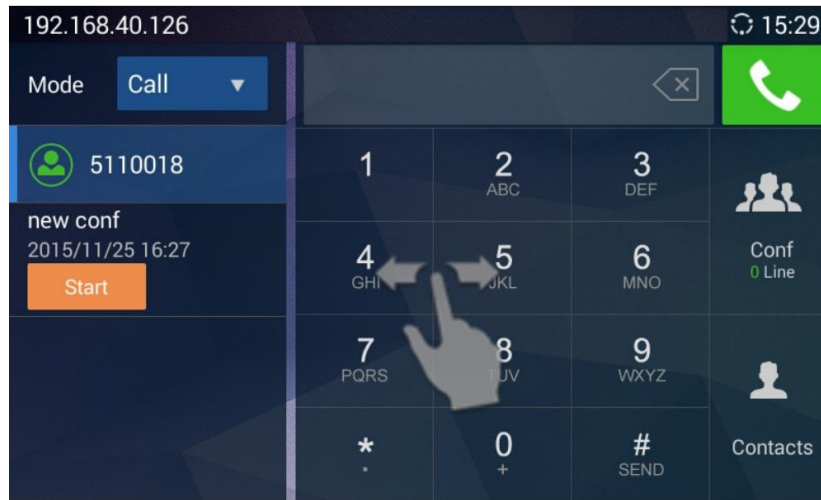

Figure 6 GAC2500 Multi-screens



- **Home Screen.** GAC2500 Home screen is a dial screen by default and cannot be modified. You can dial up or start a conference on this screen.
- **Widget.** GAC2500 supports tools and Apps like Weather Forecast, Clock, MPK, and etc.
- **Status Bar.** The GAC2500 status bar is located on the top of the screen to indicate the current status of the device. Please refer to chapter **Status Icons** for more details.
- **Soft Keys.** 5 softkeys Including Volume+, Volume-, Back, Home, and Process Manager. Drag and slide upward at the bottom of the screen o bring out soft keys, the keys will be hidden automatically if no operation timeout.







































### STATUS ICONS

Touch the status bar of GAC2500 and slowly drag it down to display the full status list. Users could view status icons that indicate the current status of the device.

The following table lists the main status icons used on GAC2500.

Table 4 GAC2500 Status Icons Descriptions

Icon	Descriptions	Icon	Descriptions	Icon	Descriptions
	Ethernet is connected		Trying to connect to Ethernet		Ethernet is disconnected

	Missed call		One line is in active		Unread voicemail
	Calls from blacklist		Call forward is set up		Auto answer is set up
	DND mode is enabled		Wi-Fi is connected		Wi-Fi is enabled but not connected
	Bluetooth is connected		Sending files via Bluetooth		Bluetooth has been plugged in
	Using Bluetooth headset for calls		Volume is turned to silent		Mute is enabled.
	Downloading		Download failed		Updating Application
	3.5mm headset is inserted		Switch 3.5mm headset line sequence		Powering the device with PoE
	PPPoE is connected		PPPoE connection failed		Missed conference
	Warnings		New message		Full messages storage
	VPN is connected		VPN connection failed		More notifications
	The USB mouse is connected		The USB keyboard is connected		VPN is connected
	RJ48 CAT5 is connected		Set GAC2500 as master device		Set GAC2500 as slave device
	Hotspot is enabled		USB device is inserted		Full USB device storage

## USING THE ONSCREEN KEYBOARD

### ENGLISH KEYBOARD

This is the default keyboard on the GAC2500. The GAC2500 English keyboard supports multiple languages input methods. Users could tap on  to switch among different languages. See figure below.



Figure 7 GAC2500 Soft Keyboard - English Input Method

Tap on  to switch Caps Lock.



Figure 8 GAC2500 English Keyboard - Uppercase

## CHINESE KEYBOARD

GAC2500 supports Google Pinyin Input, go to Settings->Language & Keyboard to configure.



Figure 9 GAC2500 Chinese Keyboard - Google Pinyin Method

## NUMBERS AND SYMBOLS

To input numbers and symbols, tap on  on the default keyboard to switch to numbers/symbols.

Tap on  for more numbers/symbols.

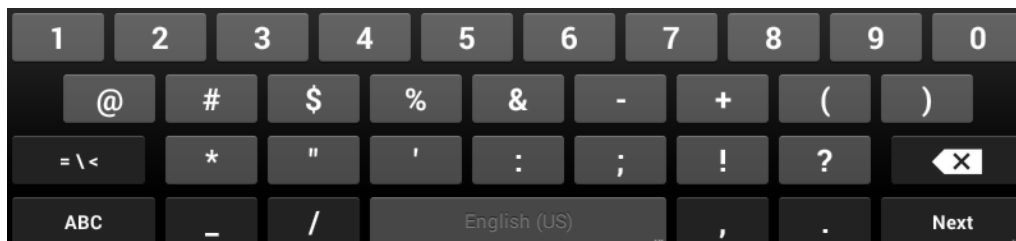

Figure 10 GAC2500 Soft Keyboard - Symbols and Numbers

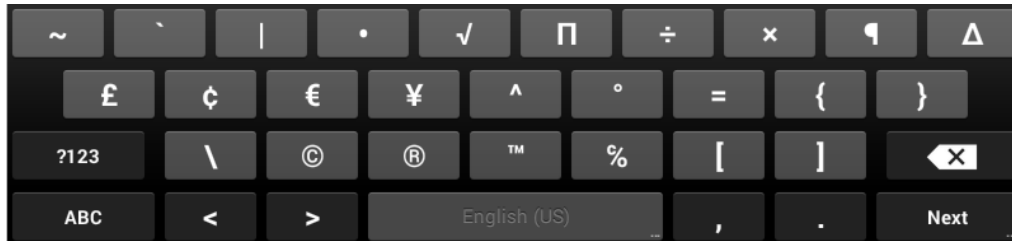







Figure 11 GAC2500 Soft Keyboard - More Symbols and Numbers

## USING THE LED INDICATOR

The GAC2500 LED indicator is located on the top part of the device. It can be used to notify the users with current status of the device. The priority of the indicator from high to low is shown below.

Table 5 GAC2500 LED Indicator Descriptions

Color	LED Indicator Status	Descriptions
	Fast Flashing	Incoming call (including calls when conferencing and when phone is busy).
	Solid	Calling, Talking, Conferencing, Screensaver status.
	Slow Flashing	Call on hold.
	Slow Flashing	Unhandled events. Including missed call (s), new voicemail (s), new SIP message (s).
	Solid	High memory usage, full message box, full contacts storage, network disconnection.
	Rapid Flashing	Upgrading.
None	OFF	Normal.



**Note:**

The colors and statuses of LED indicators are by default. You can go to Web page->Maintenance->Device Manager to custom indicators.

---



## ASSISTIVE TOUCH

GAC2500 screen supports multi-touch in full screen, users could operate the GAC2500 with touch or drag gestures.

## USING TOUCHSCREEN

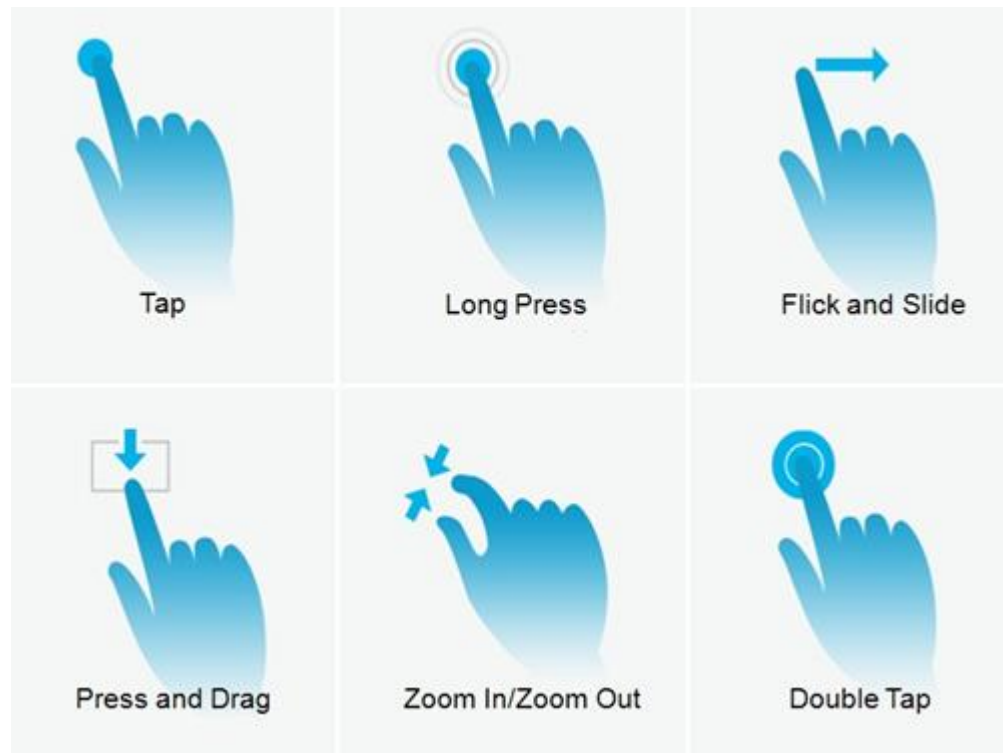



Figure 12 GAC2500 Finger Gestures

Use your fingers to operate the following gestures on the GAC2500 as shown in figure above:

- **Tap:** Briefly touch surface with fingertip once to initiate the menu, options or applications.
- **Long Press:** Touch the app for extended period of time for 2 seconds bring up operation options.
- **Flick and Slide:** Touch surface with one finger and slide over surface down to open the pull-down menu, slide over surface left, right or up to page up or make some operations.
- **Press and Drag:** Press the item and move it by dragging the finger up and down, left and right.
- **Zoom In/Zoom Out:** Touch surface with two fingers and bring them closer together to zoom out, Touch surface with two fingers and move them apart to zoom in.
- **Double Tap:** Rapidly touch surface twice with the fingertip to rearrange the zoomed page to fit the screen when viewing photos or Webpages.

## SHORTCUT KEYS

GAC2500 supports shortcuts for some special operation like Screenshots, Factory Reset, Upgrade and Security.

- **Screenshot.** Long press the Process Manager icon  on GAC2500 screen, the screenshot file will be saved automatically in the screenshot folder under SD card. Go to File Manager->Storage->Pictures->Screenshots to view files.
- **Factory Reset.** When powering up GAC2500, long press the reset button on the back of the device for more than 10 seconds to restore to factory settings.
- **Upgrade.** When powering up GAC2500, long press the button for 4 to 9 seconds to update system.

## MANAGING STATUS BAR

The GAC2500 status bar is located on the top of the screen. Touch the bar and slowly drag it down to display the full status list. Once the status bar is opened, users could view Notifications.

The Notifications in the Status Bar is as shown in figure below.

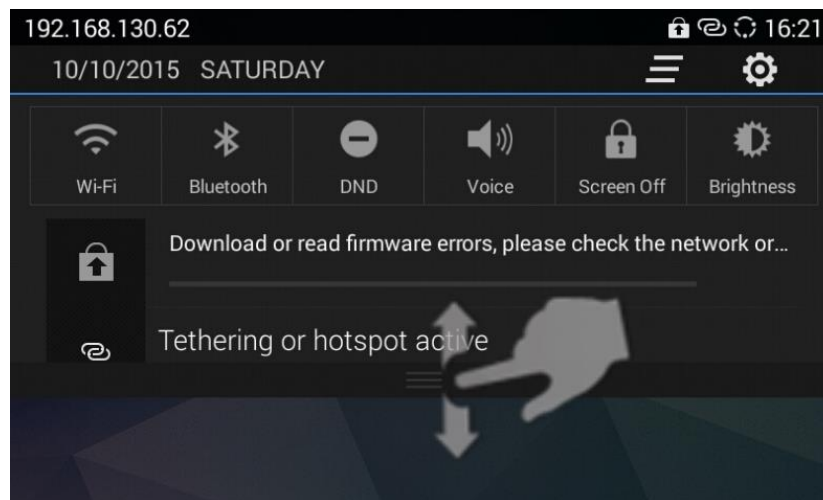



Figure 13 GAC2500 Status Bar - Notifications

Click on button  on the upper right corner to clear all notification messages.

- Slide a notification message to left or right to delete it.
- Click a notification message to view the details.
- Tap on the corresponding icon on the top of the screen to quick turn on/off the applications.
- Long press the corresponding icon on the top of the screen to quick access the applications.

- Drag the Seek Bar behind the icon  to adjust LCD brightness.

## DESKTOP MENU

When the GAC2500 is on idle screen, long press the blank area, then you can tap on "Edit desktop" or "Set wallpaper". See figure below.

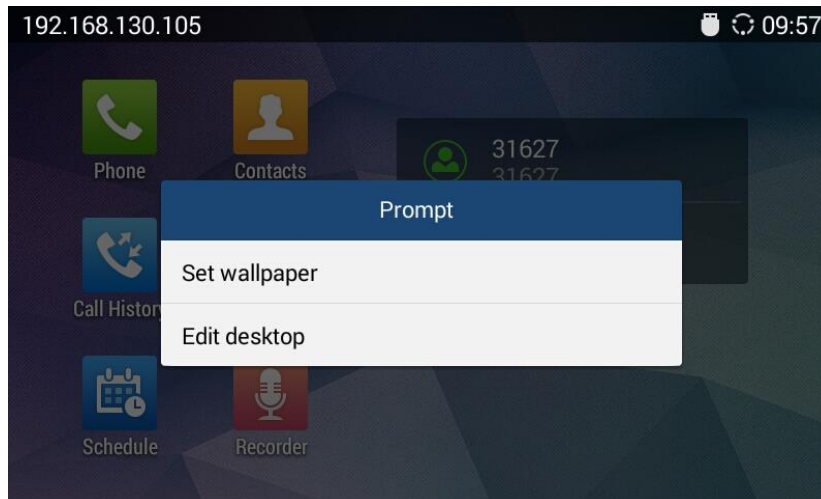

Figure 14 GAC2500 Idle Screen Menu

- **Edit Wallpaper:** Edit the idle screen wallpaper.
- **Edit Desktop:** Add, delete, edit desktop or add widgets on the desktop.

## EDIT WALLPAPER

You can set wallpapers, live wallpapers or choose photo from gallery. See figure below.

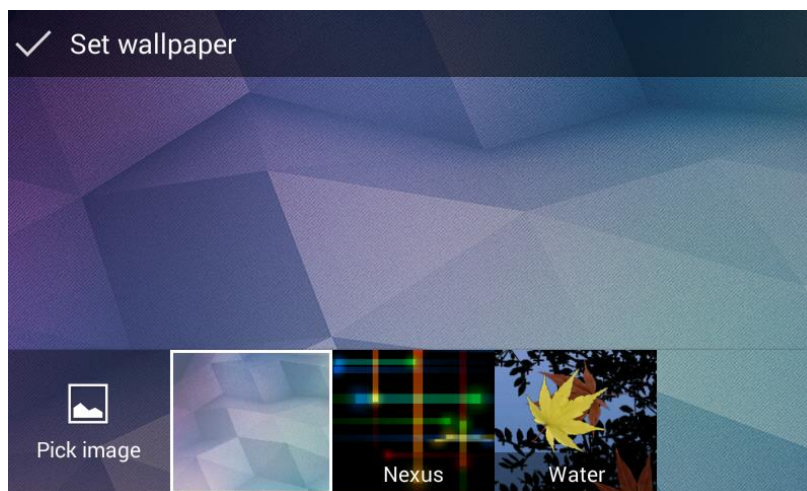

Figure 15 GAC2500 Choose Wallpaper

1. Long press the blank area on home screen then tap on "Set Wallpaper";



- Slide wallpapers to left or right to view a list of sample wallpapers embedded in the GAC2500, tap on wallpaper to preview, tap on "Set Wallpaper" to confirm the selection. You can also select photo from gallery or file manager, or set live wallpapers.

## EDIT DESKTOP

The desktop screen is as shown below.



Figure 16 GAC2500 Edit Desktop

- Add Desktop: Press finger slightly in free space of the screen and fast slide to the last screen and click  on the middle screen to add a new desktop. Users could add up to 15 desktops.
- Delete Desktop: Click  on the upper right corner of the blank desktop to delete it. The desktop with widgets and shortcuts on it is undeletable.

## ADDING AN ITEM TO DESKTOP

Users could add commonly used items (Weather Forecast, RSS News, etc.) to the desktop. Follow the steps below:

- When the GAC2500 is running on idle screen, long press the blank area, then tap on "Edit Desktop";
- Slide left or right to view a list of options;
- Press and drag the shortcut or widget you would like to add and drag it to the desktop you want to put on.



**Note:**

1. Please ensure that there is enough space on the desktop when adding widget.
2. Users may need to select the specific items before add them to the desktop. i.e., browser, bookmark, star-labeled contact, photos, etc.

## MANAGING DESKTOP APPS AND ITEMS

All the GAC2500 apps/items can be accessed /removed. Take Weather Forecast as an example in the following chapter.

### OPENING AN APP

Tap on Weather Forecast icon to access screen as shown in figure 17.



**Figure 17 GAC2500 Weather Forecast Screen**

Users could edit Weather Forecast after accessing it.

### MOVING AN APP

Touch and hold the Weather Forecast icon, when the icon begins to float, drag it to any desktop with free space.



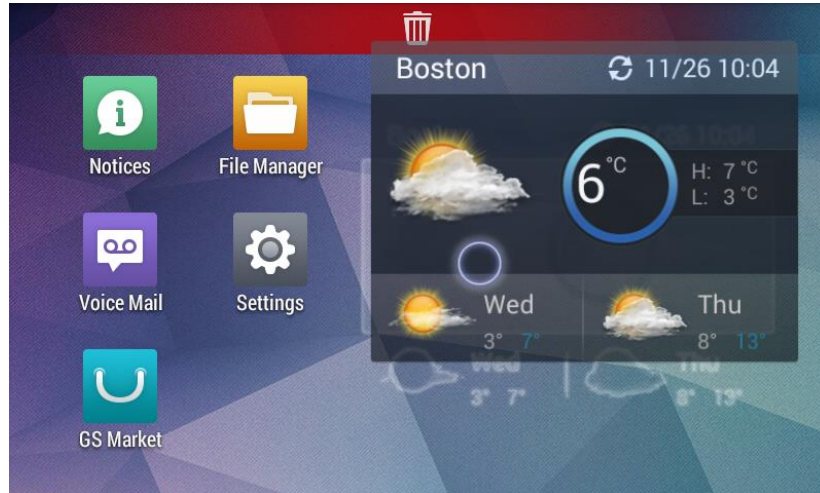



Figure 18 GAC2500 Move Weather Forecast to Desktop

## REMOVING AN APP

Touch and hold the Weather Forecast icon until the Recycle Bin  icon displayed on the top as shown in figure 18, drag the widget to the Recycle Bin, when the item gets close to the Recycle Bin, it will turn red. Now release your finger to delete.

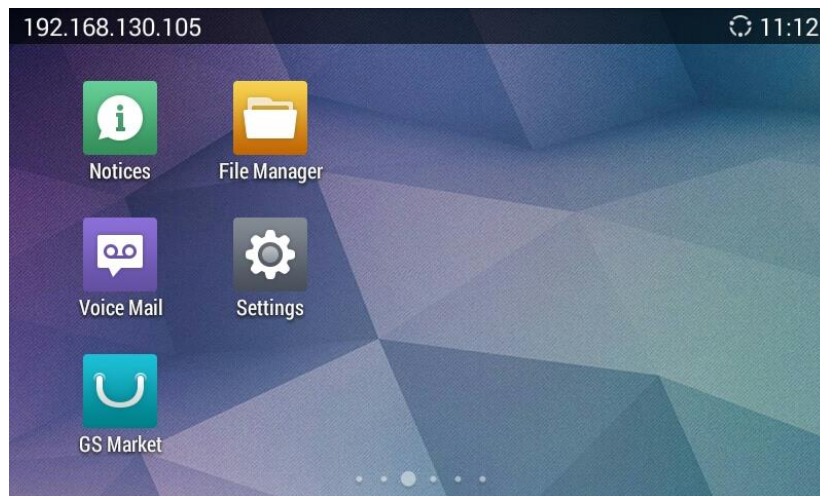



Figure 19 GAC2500 Remove Weather Forecast from Desktop



Note:  
The system applications cannot be deleted.

## MANAGING APPLICATIONS

Tap on the Process Manager icon  on screen to view the running applications on the GAC2500 as shown below.

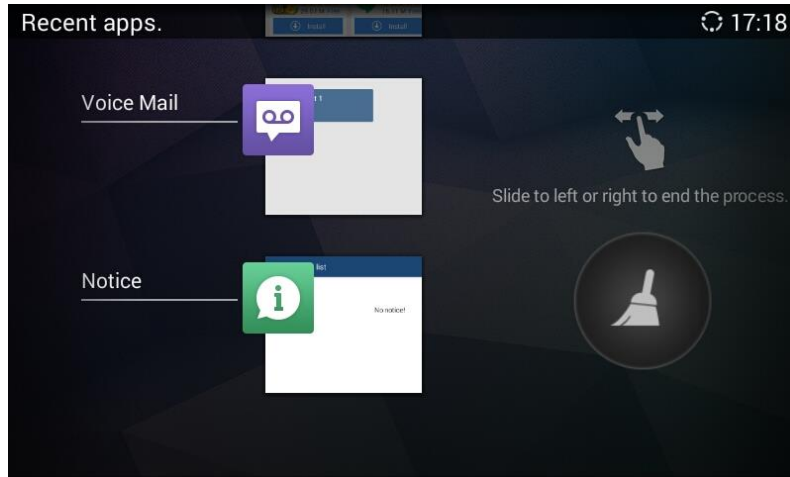



Figure 20 GAC2500 Managing Applications

Slide up/down to view the applications, tap on one and slide left/right to turn it off, or tap on it to access the corresponding interface.

Tap on  to turn off all running applications.

## HOME SCREEN

GAC2500 has only one default home screen, drag and slide upward at the bottom of the screen o bring out soft keys, tap on the icon  on the middle bottom of the screen to go back to home screen anytime.

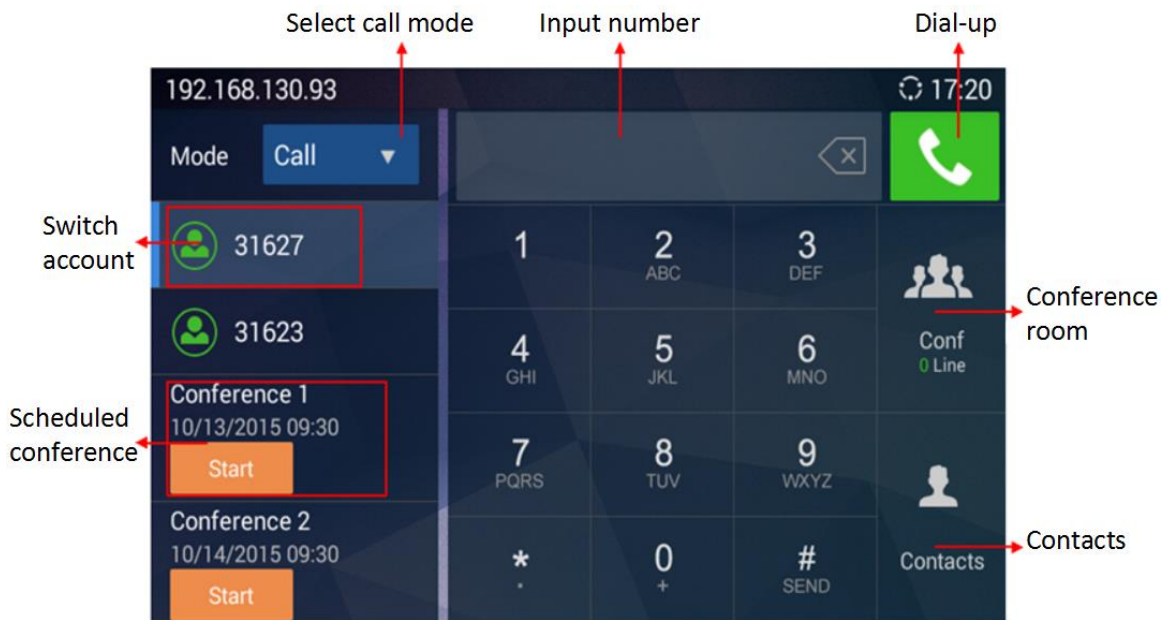

Figure 21 GAC2500 Home Screen

1. **Mode.** Set the call mode.
2. **Account.** Display all registered accounts. Tap to select account.
3. **Input box.** Tap on digits below to input phone number, or tap on the input box to bring out the soft keyboard. You'll see all the matching numbers on the left when you inputting digits, tap on the number to add it to input box directly, you can add up to 6 numbers.
4. **Dial-up.** Tap to dial out.
5. **Conference.** Display the conference line. Tap to access conference interface.
6. **Contacts.** Tap to access Contacts interface to add more contacts to the input box.
7. **Schedule Conference.** Display the latest 2 scheduled conferences. Tap on "Start" to start conference at once.

You can slide left or right to view applications and widgets on other desktops, or dial out or start conference on home screen.



## CONNECTING TO NETWORK AND DEVICES

The GAC2500 supports a variety of network connections (Ethernet, Wi-Fi) and device connections, you can configure on GAC2500 or log in the GAC2500 web UI to configure. For more information about using web UI, please refer to the GAC2500 Administration Guide in [www.grandstream.com](http://www.grandstream.com).

### NETWORK

Network connection has a variety of ways, one is wired connection via the cables, and the other way is to connect via Wi-Fi.

### ETHERNET

If the user would like to use Ethernet connection for network access, please connect the Ethernet cable to the LAN port of the GAC2500. Ethernet connection is turned on as DHCP by default.

To configure Ethernet settings on GAC2500:

1. Plug the Ethernet cable into the LAN port on the back of the GAC2500.
2. Go to LCD menu->Settings->Network->Ethernet->IPv4 Settings.
3. Tap on "Address Type" to select DHCP, Static IP or PPPoE as the address type.
  - For DHCP, save the setting and the GAC2500 should be able to get IP address from the DHCP server in the network.
  - For static IP, enter IP Address, Subnet Mask, Default Gateway, DNS Server and Alternative DNS server for the GAC2500 to correctly connect to the network.
  - For PPPoE, enter PPPoE account ID and password so the GAC2500 can get IP address from the PPPoE server.

### WI-FI

Wi-Fi is supported and built-in on the GAC2500. On the LCD display, go to Settings->Network-> Wi-Fi to turn on and configure Wi-Fi.

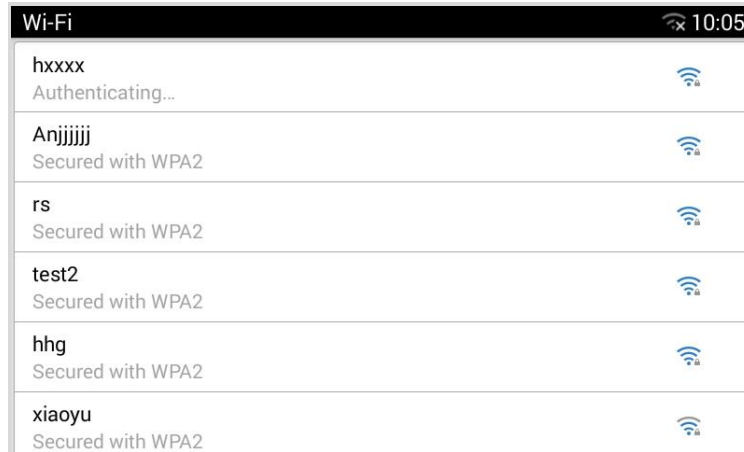

Figure 22 GAC2500 Add Wi-Fi Screen

## TURNING WI-FI ON OR OFF

Once Wi-Fi is turned on, GAC2500 will automatically start the scanning within the range. A list of Wi-Fi networks will be displayed as scanning result. Tap on the SSID and enter the correct password information to connect to the selected Wi-Fi network.

Follow the steps below for static IP usage in Wi-Fi environment:

1. Tap on one Wi-Fi network in the scanned Wi-Fi list to bring up the dialog that shows signal strength, security, password and option "Show advanced options".
2. Select "Show advanced options". The dialog will show additional option "IP settings".
3. In "IP settings", select Static IP, enter IP Address, Subnet Mask, and Default Gateway for the GAC2500 to correctly connect to the network.

## BLUETOOTH

Users could use the Bluetooth to send or receive files to cellphone, or use Bluetooth speaker and etc.

### TURNING BLUETOOTH ON OR OFF

There are two ways to enable Bluetooth:

- On the LCD display device, go to Settings->Network->Bluetooth.
- Click  to enable the Bluetooth in the drop-down status bar.

### PAIRING GAC2500 WITH A BLUETOOTH DEVICE

Before connecting GAC2500 with other Bluetooth device, users must pair them first. They will stay paired afterwards unless they are manually unpaired. To pair Bluetooth device:

1. On the LCD display device, go to Settings->Network->Bluetooth.

2. Press  button on the remote control and select "Search for devices".
3. The GAC2500 scans and displays the IDs of all available Bluetooth devices in range. Once the Bluetooth device shows up in the result, tap on it to start pairing.
4. Confirm the passkey in the prompted message (if any). Or if passcode is required, please refer to the device's documentation or other procedures to obtain the passcode.

## CONNECTING TO A BLUETOOTH DEVICE

After successfully paired, the device will be connected to the GAC2500 immediately. Users will see this device listed under "Paired Devices". Tap on  next to the connected device. Users will see options "Rename", "Unpair" and etc.

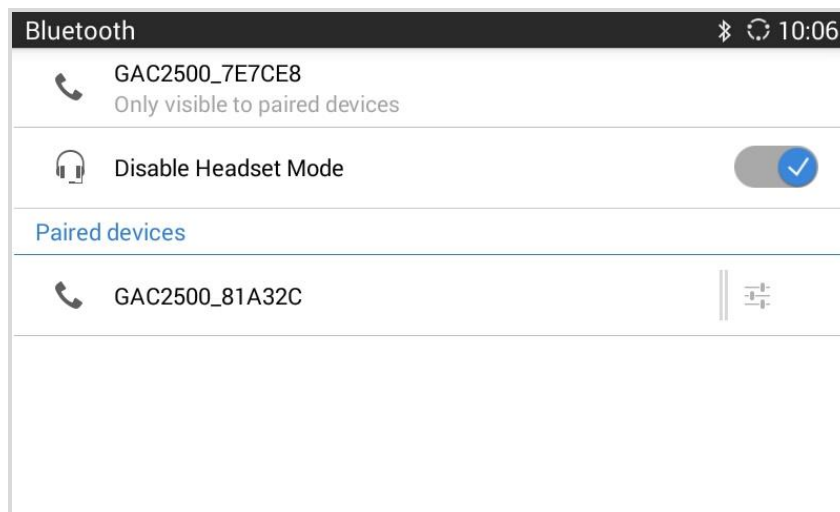

**Figure 23 GAC2500 Bluetooth - Paired Device**

If the connection is lost between the Bluetooth device and GAC2500, go to LCD menu->Settings->Network->Bluetooth and click on the device name under "Paired devices" again to reconnect.

When enabled headset mode, the connected Bluetooth device could use GAC2500 as a headset audio device. You can see the Bluetooth device is displayed as an account on the left home screen. You can make dial-ups with this account directly, or as a party to join conference.

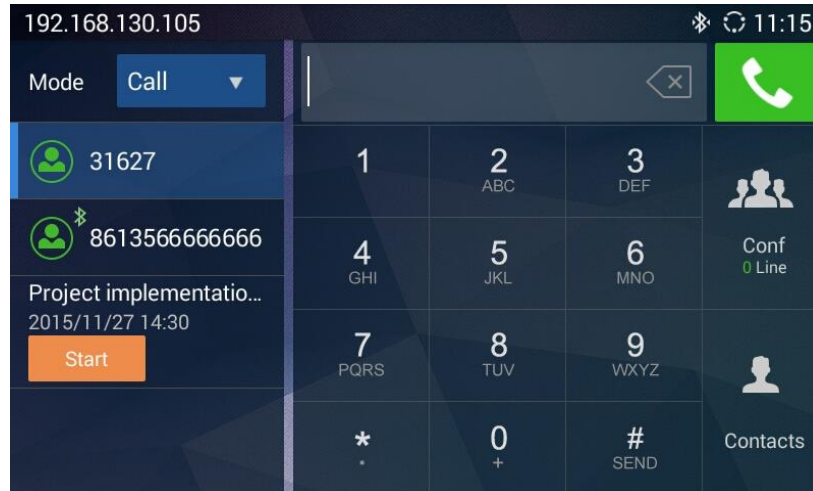

Figure 24 GAC2500 Bluetooth - Paired Device



**Note:**

1. When enabled Bluetooth headset mode, a pop-up dialog will prompt to remind users whether import contact or call history from Bluetooth device(your phone), if agree, when you input digits in input box, the device will automatically start contact/call history matching.
2. When enabled Bluetooth headset mode, when your Bluetooth device has an incoming call, GAC2500 also rings and displays call screen at the same time. You can either answer the call with your Bluetooth device or GAC2500.
3. When enabled Bluetooth headset mode, you can switch audio channels freely on your Bluetooth device.
4. please note when enabled Bluetooth headset mode, making calls with Bluetooth account is actually with your device and it may generate flow/communication fees, GAC2500 only serves as a Bluetooth headset to transmit and control audio.

## SENDING FILES VIA BLUETOOTH

Users could transfer files, share contacts information from other Bluetooth portable devices to GAC2500 after pairing and connection. A prompt for file transferring will be displayed on GAC2500 LCD display device when the GAC2500 receives the file transferring request. Accept the request to receive file and the file will be stored under SD Card/Bluetooth directory.

## VPN SETTINGS

Users can add VPN using different protocols. Follow the steps below to set up VPN.

1. Access GAC2500 home screen, go to Applications ->Settings ->Network->VPN;
2. Tap on "Add VPN file" to access configuration page as shown below;

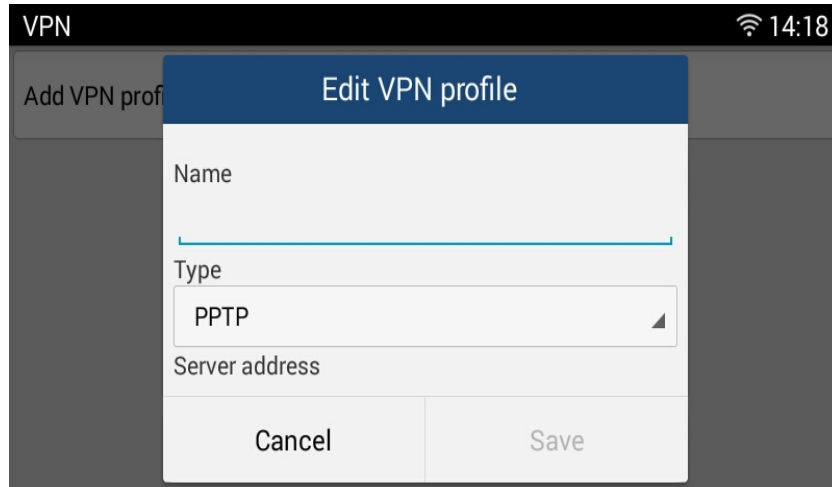

Figure 25 GAC2500 Add VPN Files Screen

3. Fill in parameters and save, go back to VPN page, you will find the new VPN file you just added;
4. Tap on the VPN file to open the validation page, fill in correct username and password to connect to VPN.



If the GAC2500 is connected to VPN successfully, icon  will be shown in the top status bar; if the connection is failed, a prompt box will pop up to remind users whether to connect again. If icon  displays in the top status bar, please check whether your VPN configuration is correct.

Table 6 GAC2500 VPN File Parameters

Parameters	Descriptions
<b>Name</b>	Fill in your company address or the server you are connecting to.
<b>Type</b>	Set to PPTP, L2TP/IPSec PSK, L2TP/IPSec RSA, IPSec Xauth PSK, IPSeXauth RSA or IPSec Hybrid RSA.
<b>Server Address</b>	Fill in the server URL or IP address.
<b>PPP Encryption (MPPE)</b>	Define whether to use PPP encryption.
<b>Show Advanced Options</b>	Check to display more options below.
<b>DNS Search Domains</b>	Define search domain.
<b>DNS Server</b>	Input DNS server address.
<b>Forwarding Routes</b>	Input Forwarding Routes. For example, 10.0.0.0/8.

## VLAN SETTINGS

Access GAC2500 home screen, go to Applications->Settings->Network->VLAN to configure VLAN settings on the GAC2500.

Table 7 GAC2500 VLAN Configuration Parameters

Parameters	Descriptions
<b>Layer 2 QoS 802.1q/VLAN Tag</b>	Assigns the VLAN Tag of the Layer 2 QoS packets for LAN port. The default value is 0. <b>Note:</b> Please do not change the setting before understanding the VLAN's settings or consulting the network administrator. Otherwise, the device might not be able to get the correct IP address.
<b>Layer 2 QoS 802.1p Priority</b>	Assigns the priority value of the Layer 2 QoS packets. The default value is 0.

## LLDP SETTINGS

Access GAC2500 home screen, go to Applications ->Settings ->Network->LLDP to configure LLDP settings on the GAC2500.

Table 8 GAC2500 LLDP Configuration Parameters

Parameters	Descriptions
<b>LLDP</b>	Enable or disable LLDP. The default setting is disabled.
<b>Layer 3 QoS for SIP</b>	This field defines the layer 3 QoS parameter for SIP packets. It is the value used for IP Precedence, Diff-Serv or MPLS. The Default value is 48.
<b>Layer 3 QoS for Audio</b>	This field defines the layer 3 QoS parameter for audio packets. It is the value used for IP Precedence, Diff-Serv or MPLS. The Default value is 48.
<b>Layer 3 QoS for Video</b>	This field defines the layer 3 QoS parameter for video packets. It is the value used for IP Precedence, Diff-Serv or MPLS. The Default value is 48;

## 802.1X MODE

Access GAC2500 home screen, go to Applications ->Settings ->Network->802.1X Mode. By default 802.1X is disabled. Select 802.1X mode to "EAP-MD5", "EAP-TLS5" or "EAP-PEAP" to turn on 802.1X. Once 802.1X mode is enabled, the user will be required to enter the identity and Password to be authenticated in the network.

**Table 9 GAC2500 802.1X Mode Parameters**

Parameters	Descriptions
<b>802.1x Mode</b>	Allows the user to enable/disable 802.1X and configure 802.1X mode. The default setting is disabled.
<b>Identity</b>	Enter the Identity information for the 802.1X mode.
<b>MD5 Password</b>	Enter the MD5 Password for the 802.1X mode.
<b>CA Certificate</b>	Upload the CA certificate for the 802.1X mode.
<b>Client Certificate</b>	Upload the CA certificate for the 802.1X mode.
<b>Private Key</b>	Upload the private key for the 802.1X mode.

## MAKING PHONE CALLS

### ACCOUNT

GAC2500 supports up to 6 independent SIP account and 1 BlueJeans™ account. Users need to register their own accounts to the SIP server to make calls via the account.

The following figure shows the account is successfully registered (account icon is highlighted in green).

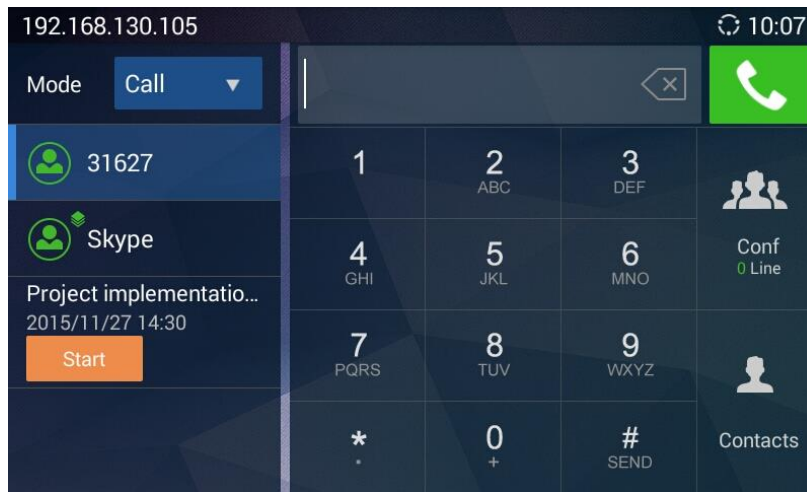



Figure 26 GAC2500 Registered Account Status

### MAKING A CALL

#### DIRECT DIALING

GAC2500 home screen is the dial screen or you can tap on  on desktop to access dial screen.

1. Enter the dial screen, select account and call mode;
2. Enter the necessary digits on the keypad;
3. Tap on  to dial out.



**Note:**

1. GAC2500 allows users to configure the "#" key as the "Send" key. If users need to cancel this setting, please log in the built-in Web page to set the parameter "use # as the dial key" to "No".
2. Enter digits in the dial-up box. If the digits or the letters for the digit matches contacts and call history, a dropdown list of numbers will be displayed. For example, entering 5 (JKL), 6 (MNO), 4 (GHI) and 6 (MNO) will display 5646 or john if contact "john" exists. Users can then select it to dial out.



## REDIAL

Redial is to dial the last dialed-out number. It is only available when the call log exists.

1. Enter the dial screen;
2. Press the button  or tap on "#" to dial the last dialed-out number automatically.



Note:



You can redial the last dialed-out number, but unable to dial the conference.

## DIALING A NUMBER VIA CONTACT

Follow the steps below to dial a number via Contacts.

1. On the LCD display device, access Contacts by tapping on the icon on home screen.
2. Navigate and select in the Contacts entries using the remote control navigation keys.
3. Tap on the dial key  to dial out.

## DIALING A NUMBER VIA CALL HISTORY

1. On the LCD display device, access Applications on home screen and access call history by selecting  icon.
2. The LCD will display all call history types. Navigate in the call history list by selecting the call history category. Select the call history entry you would like to dial out.
3. Press  to dial out.

## DIRECT IP CALL

Direct IP Call allows GAC2500 and another VoIP device to talk to each other in an ad-hoc fashion without a SIP proxy. VoIP calls can be made between these two if:

- Both GAC2500 and VoIP phone have public IP addresses  
Or
- Both GAC2500 and VoIP phone are on the same LAN / VPN using private or public IP addresses  
Or
- NAT is disabled or GAC2500 NAT is disabled.

Both devices can be connected through a router using public or private IP addresses (with necessary port forwarding or DMZ).

To make a direct IP call, please follow the steps below:

1. Access the dial screen on GAC2500;
2. Set the mode to "IP Call";
3. Input the target IP address. For example, if the target IP address is 192.168.124.123 and the port is 5062, input the following:  
192\*168\*124\*123#5062  
The \* key represents the dot (.) and the # key represents the colon (:).
4. Press  to dial out.

### PAGING/INTERCOM

Before placing paging/intercom, please make sure the callee has paging/intercom enabled so it can automatically answer the paging/intercom call. To make paging/intercom call:

1. Access the dial screen on GAC2500;
2. Set the mode to "Paging";
3. Enter the number to dial;
4. Press  to dial out.

### ANSWERING A CALL

When the device is in idle and there is an incoming call, the device will show the call screen as below.

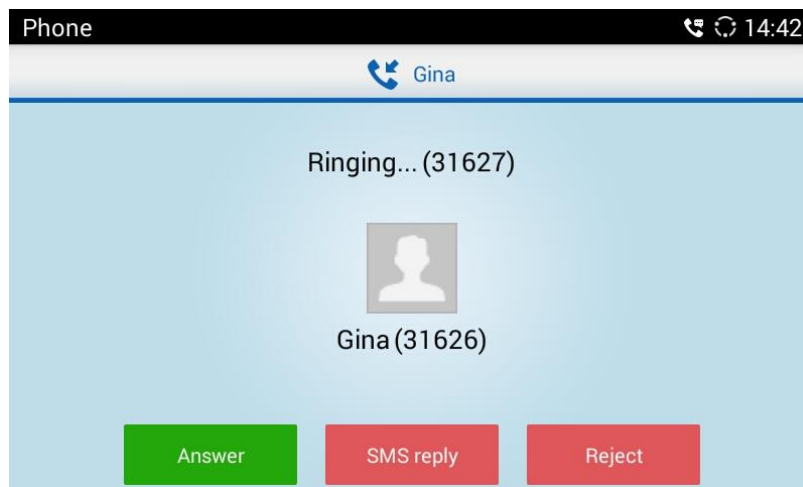

**Figure 27 GAC2500 Single Incoming Call Screen**

Select "Answer" to answer the call, or reject the call by pressing the "Reject" softkey.

When there is an incoming call during an active call, users will hear a call waiting tone with the LCD displaying the caller name and ID for the incoming call.

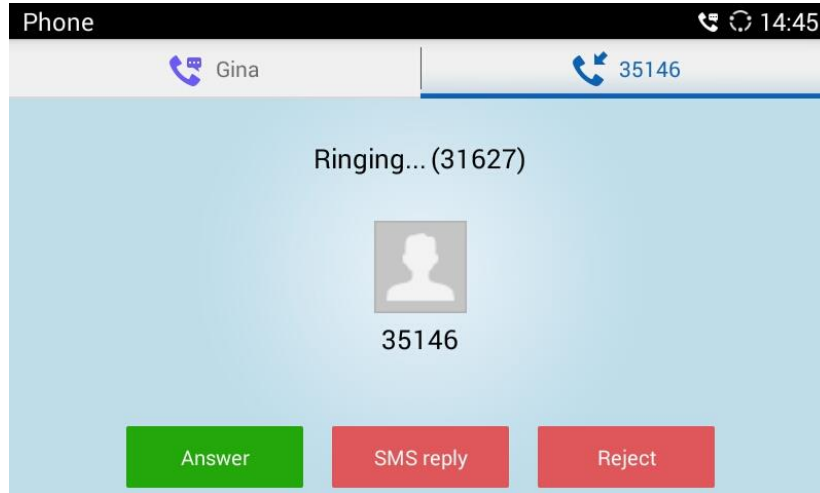



Figure 28 GAC2500 New Incoming Call Screen

Users could select "Answer" to answer with audio only, or eject the call by pressing the "Reject" softkey.

## REJECT CALL VIA SMS

Users could reject incoming calls via messages. Please access Notices application  on desktop

and tap on Settings  on the upper right corner, and enable "Enable Quick Reply". You can also

tap on  below to custom your reply.

Once enabled "Enable Quick Reply", when there is an incoming call, you can tap on "SMS reply" to access quick reply list, select the reply to send the reject call.



Note:

Notices reject function works when the callee sends the SIP message to the caller to reject call, please confirm your service provider supports this service.

---

## CALL MANAGEMENT

During an active call, you can make other operations like hold/hold, mute/unmute, call recording, add a new call, start conference, or end the call.

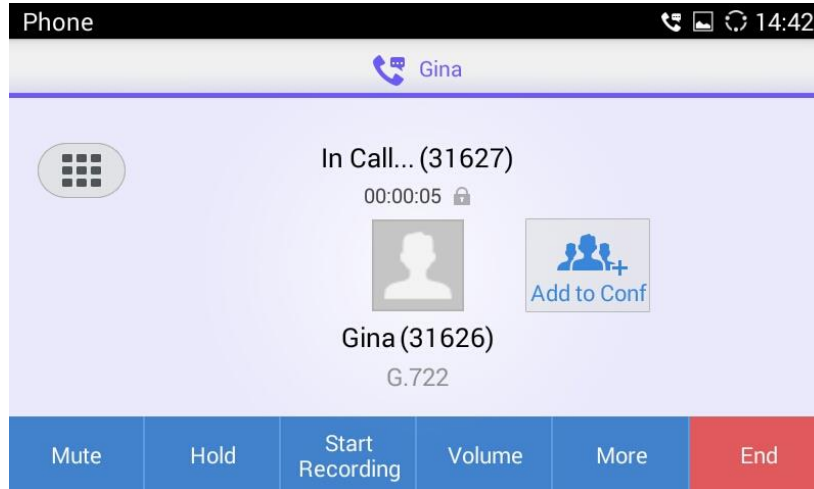



Figure 29 GAC2500 Single Incoming Call Screen

- **Call Lines.** Display the current line status: active, hold, incoming, outgoing.
- **Add to Conf.** Tap to add all active lines to conference members.
- **Mute/Unmute.** Tap to mute/unmute the call.
- **Hold/Unhold.** Tap to hold/hold the call.
- **Start Recording.** Tap to start/stop recording.
- **Volume.** Tap to bring up the volume bar to adjust the volume.
- **More.** Bring up more options including like MPK, Transfer, etc.
-  **DTMP Keypad.** Tap to bring up the DTMF keypad.
- **End.** End the current line.

## CALL HOLD AND CALL RESUME

### CALL HOLD

During the active call, press HOLD button to put the current call on hold. Users could then make or answer a new call. It shows as follows:

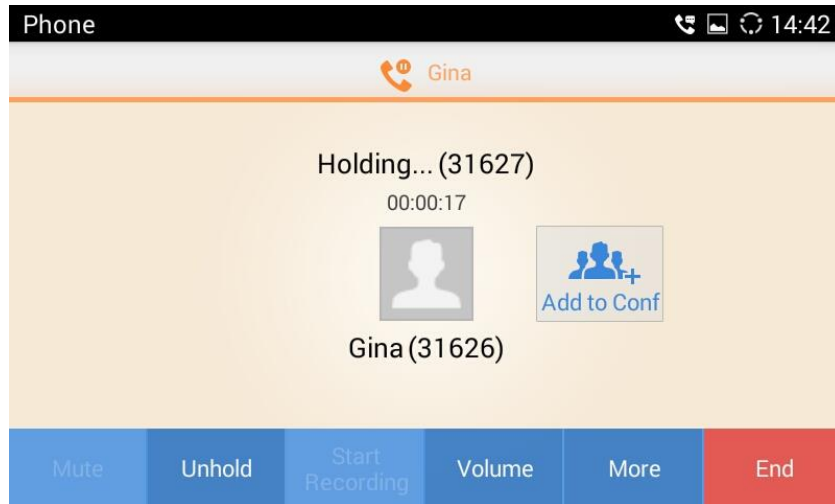

Figure 30 GAC2500 Call On Hold Screen

## RESUME TO CALL

If the active call is on hold, users could press the "Unhold" button to resume call or tap on the "End" button to hang up the call.

## CALL RECORD

Users could save the call conversations to the GAC2500 by recording during an active call. You can listen to the recordings from Recorder, please refer to the chapter **Recorder** for details.

1. During an active call, tap on the Record icon in the upper right corner to start recording as shown in the figure 30 below:

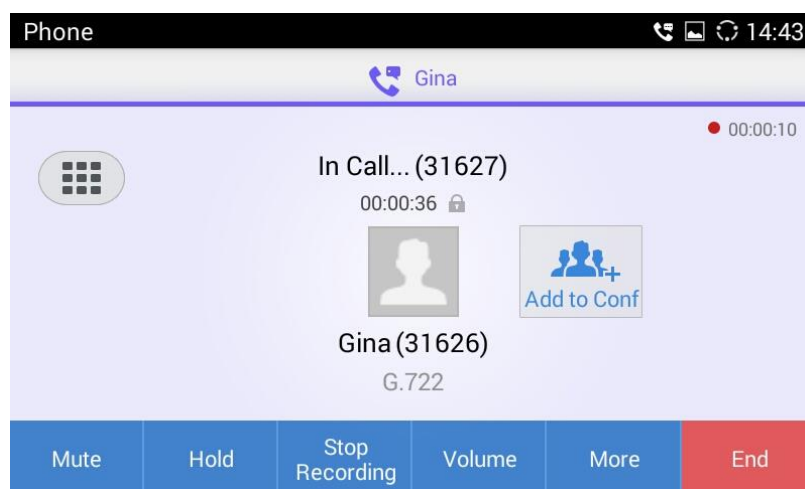

Figure 31 GAC2500 More - Start Recording

2. Tap on the icon again to stop recording.

## MUTE

During the active call, you can tap on the "Mute" button to mute the call, you will not be heard by others. The screen is as shown below.

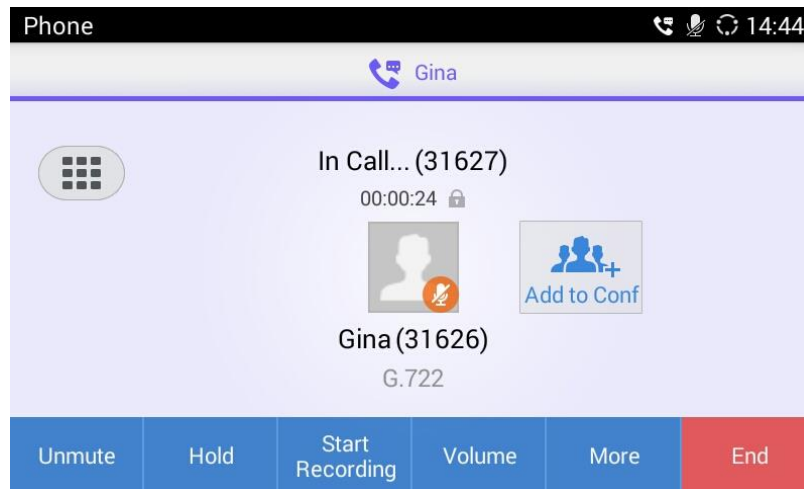

Figure 32 GAC2500 Mute Call Screen

## CALL TRANSFER

Call transfer is to transfer one call to another call. Call transfer including blind transfer and attended transfer according to different situations. For example, if user A wants to transfer the call with user B to user C, blind transfer or attended transfer is optional.

### BLIND TRANSFER

1. User A and user B are in an active call.
2. User A tap on Transfer button to bring up the transfer screen;
3. Set the transfer mode to Blind .The default mode is Blind;
4. Enter the digits and press the SEND to transfer the call with user B to User C. When user C's phone rings, the phone interface of user A is shown in figure 32. If user C answers the call, user A will automatically go back to the idle screen, which indicates the successful transfer;

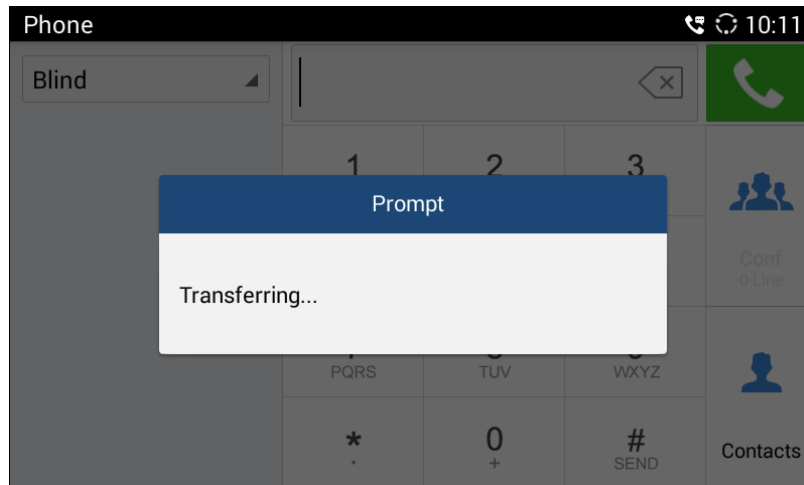



Figure 33 GAC2500 Transfer - Blind Transfer

5. User C's phone will ring, the phone with CID function will display user B's number on screen as the caller.



**Note:**

1. If inputted the wrong digits, press the button  to delete the digit one by one, or long press the button to empty all digits.
2. Users could tap on Back icon to go back to the active call interface if wants to cancel transfer.

## ATTENDED TRANSFER

There are two ways of attended transfer: Call Forward and Call Transfer.

### CALL TRANSFER

1. User A and user B are in an active call;
2. User A presses the button  to add a new line with user C. The call with user B will be automatically put on hold;
3. User C answers the phone to set up the line with user A;
4. User A taps on More button in the menu then choose Transfer to bring up the transfer screen. The line with user B will be displayed on screen;
5. User A sets the transfer mode to Attended then choose to display user B's number, the call will be transferred to user C. User B and user C could talk directly via the phone.

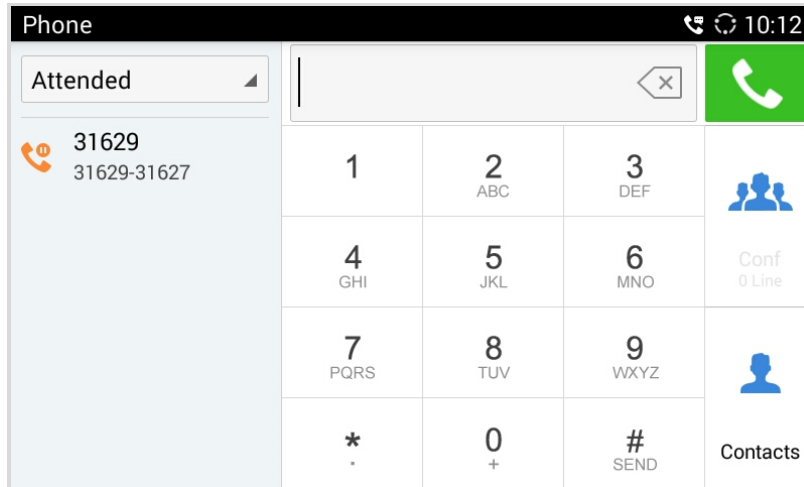

Figure 34 GAC2500 Transfer - Attended Transfer

## CALL FORWARD

1. User A and user B are in an active call. User A tap on More button in the menu to choose Transfer to bring up the transfer screen;
2. Select the Transfer mode. As shown in figure 34;

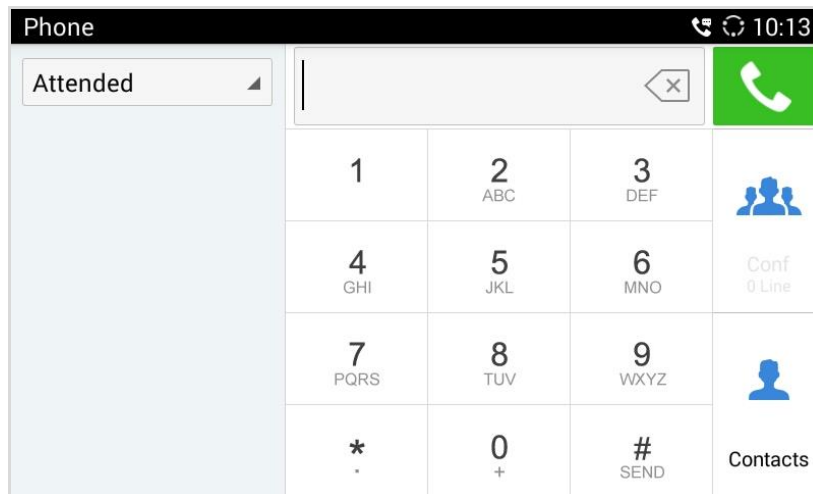

Figure 35 GAC2500 Call Forward - Select Forward Mode

3. Input digits and then press the Send soft key;
4. Users will hear the ringback tone and see the prompt as shown in figure 35. Hang up the phone to transfer the call to the third party C automatically; press the "Cancel" button will cancel the transfer;





2. Touch the DND icon  to turn it on/off.



**Note:**

1. When DND is on, the active call will not be affected, all the calls after to the registered accounts will be blocked.
2. When DND is on, the incoming calls to the GAC2500 will be saved in the call history.

## MISSED CALL

When there is a missed call, the LCD will show missed call screen instead of regular idle screen. Users can tap on the one of missed call entry to access the missed call log. To close the missed call

screen and return to the idle screen, tap on  on the upper right.

## CALL FORWARD

Call forward (Unconditional/No-answer/Busy/Time-based) can be set up on device or from web GUI. Log in GAC2500 web GUI and go to Settings page->Account->Call Settings. For details, please refer to "GAC2500 Administration Guide".

### SET ON LCD

1. Go to Settings->Personalized Account to select the account and access configuration page;
2. Tap on Call Forward Type to access and specify the forward type:

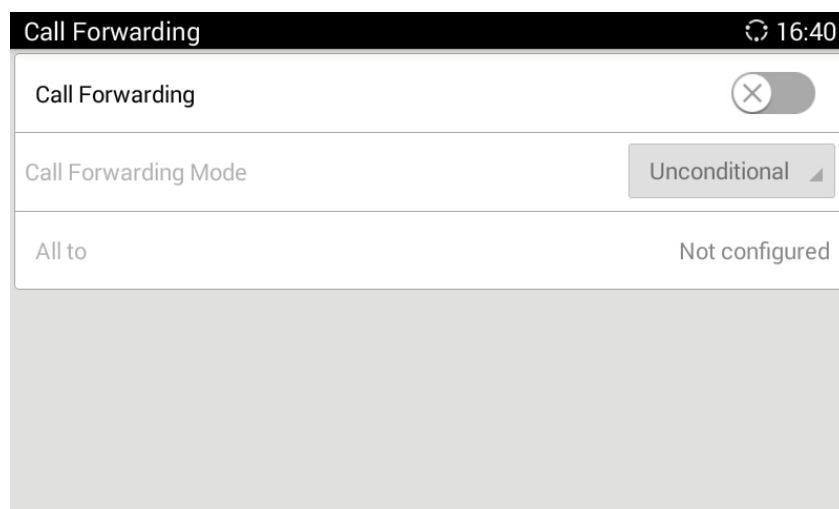

Figure 38 GAC2500 Call Forward Type Setting Screen

- **Unconditional:** Forward all calls to particular number

- **Time based:** Forward calls based on the time range.
- **Busy:** Forward calls when an active call exists.
- **No-answer:** Forward calls when phone is not answered.

## SET FROM WEB GUI

Log in the Web GUI and go to Account->Call Settings to find Call Forward option as shown below and specifies the call forward mode in the drop-down list.

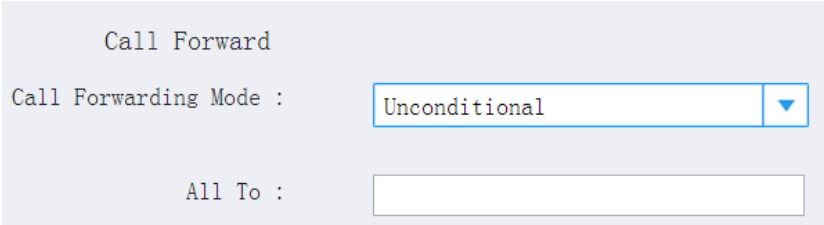

**Figure 39 GAC2500 Call Forward Mode On Web GUI**





## 7-WAY CONFERENCE

The GAC2500 supports up to 7-way conference. The GAC2500 can be the host to initiate a conference or join other conferences as a party.

### INITIATING CONFERENCE

The conference can be initiated from dial screen, or start conference from schedule.

The following steps introduces the 2 ways to start conference from dial screen, please refer to chapter **Schedule** for more details about initiating conference from schedule.

- Enter multiple numbers in the text box or select parties from the list below.
  1. Access dial screen when the phone is on idle;
  2. Set call mode and select account;
  3. Enter digits in the textbox;
  4. Tap on the matching phone number on the left to add it to the textbox, you can add multiple numbers.
  5. Repeat the steps 3-4 to add more numbers;
  6. Tap on  to dial out.
- Press  to access conference page, then tap on  to add parties.
  1. Access dial screen when the phone is on idle;
  2. Tap on Conf button  or the icon  on desktop to access conference page as shown below;

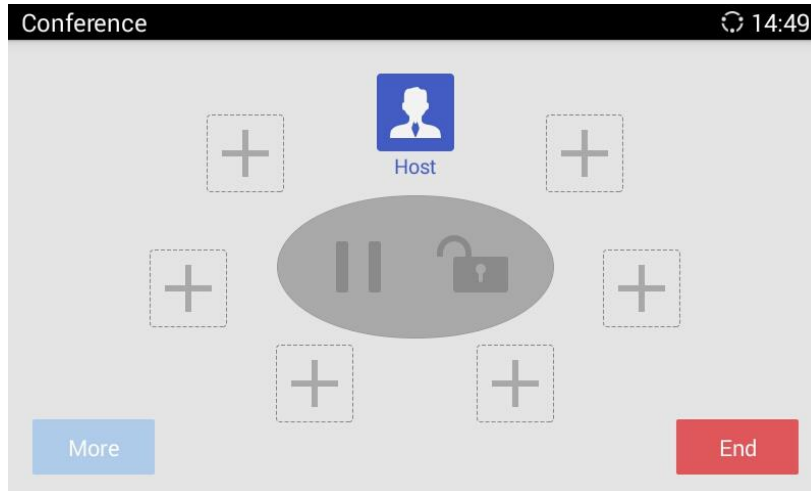



Figure 40 GAC2500 Conference Screen

3. Tap on  to start adding parties to conference;

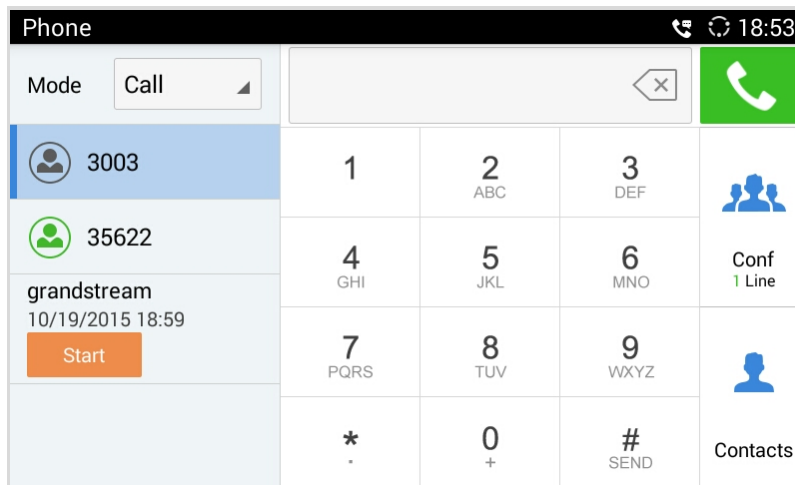



Figure 41 GAC2500 Add Party To Conference

4. Enter digits and then tap on  to dial out;
5. Repeat the steps 3-4 to add more parties.



**Note:**

1. You can add multiple members to conference at one time.
2. You cannot stay in one single active line once joined conference.

### ANSWERING AN INCOMING CALL IN CONFERENCE

You can specify how your GAC2500 handles incoming calls. Depending on your configuration, your GAC2500 automatically answers a call or prompts you to answer a call manually:

Log in GAC2500 web GUI and go to Settings page->Account->Call Settings and set "Auto-answer" option to "Yes", or go to Settings->Personalized Account->Account and set "Auto-answer" option to "Yes" on

GAC2500. Once enabled, All incoming calls will be automatically answered, you can see the icon  displayed on the status bar.

### CONFERENCE MANAGEMENT

The following figure shows a 3-way conference established.

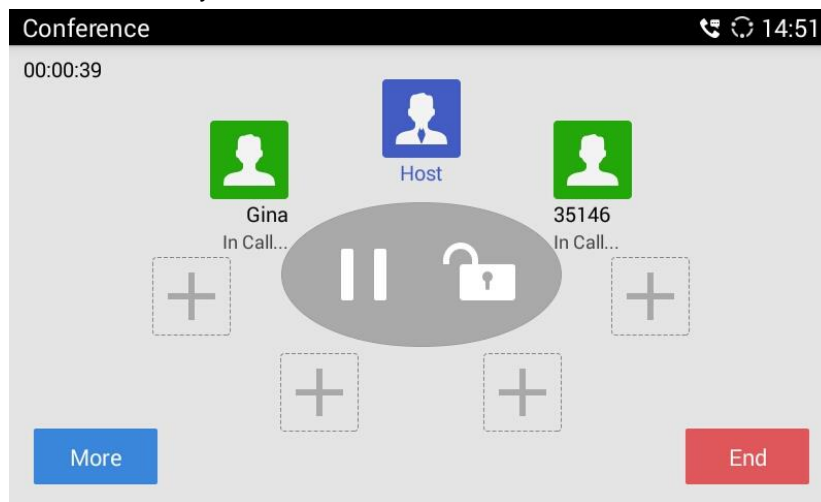











Figure 42 GAC2500 3-Way Conference

Tap on participant icon to bring up more options.

 **Redial.** Tap on the icon to dial out again if the call failed.

 **Mute.** Once enabled, the icon next to the conference member will turn to , and the Mute icon becomes . The selected member will not be heard by other parties. You can tap on  to unmute the member.

 **Block.** Once enabled, the icon next to the conference member will turn to , and the Block icon becomes . The selected member will not hear other members. You can tap on  to unblock the member.

 **Details.** Tap to view conference details, including whether to use SRTP or codec.

 **Delete.** Tap to delete conference members.

**More.** Bring up more options including Open DTMF, Mute All, Block All.etc.

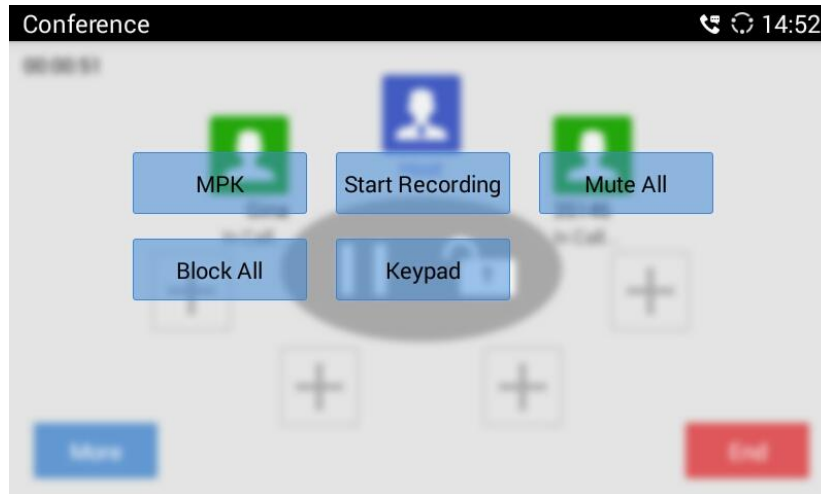

Figure 43 GAC2500 Conference-More

- **MPK.** Tap to access MPK interface.
- **Mute All.** Tap to mute/unmute all parties except the host.
- **Block All.** Tap to block/unblock all parties except the host.
- **Start Recording.** Tap to start/stop recording. The recording file will be saved automatically.
- **Keypad.** Tap to pen DTMF keyboard.



 **Hold.** Hold/Unhold conference.

 **Lock.** Lock/Unlock conference.

**End.** End conference and go back to home screen.

## INVITE MEMBERS TO CONFERENCE

Users could use one of the following ways to add members.

- Access the dial screen by clicking on the ADD icon  on conference screen. Then enter the number to dial out. Once the member answers the call, it will be connected into the conference automatically.
- Tap on  to access the dial screen, then enter the number to dial out. Once the member answers the call, it will be connected into the conference automatically.
- The member calls the conference number. If the host answers the call, the member will join conference automatically.

## REMOVING MEMBER FROM CONFERENCE

To remove a member from the conference, tap on the member icon and click  to delete it.

## THIRD PARTY APPLICATIONS

The GAC2500 runs the Android Operating System and therefore offers full access to the hundreds of thousands of Android apps in the Google Play Store, including Skype for Business™, Google Hangouts™ etc.

For example, to use third party app Skype for Business™ during the conference:

1. Establish a conference call on the GAC2500;
2. On conference screen, click on ;
3. Input numbers or contacts of Skype for Business™ and dial out;
4. The new call will be added to conference.



### Note:

1. You should install the third party app and sign in first.
2. You should go to Web gui ->Advanced -> Call Features and set Display Soft Keyboard as Yes.
3. Some third party apps may not support the GAC2500's dial pad, you have to go to the application's gui to dial out.
4. If you dial SIP numbers and third party apps' numbers at the same time, the SIP numbers will be dialed out first and go to the conference room, you need return to the dial pad, and then the third party apps' numbers will be dialed out automatically.
5. In order to fully use of Skype for Business™ (Lync), you should download it from the GS Market. Other versions may not compatible.

## END CONFERENCE

To end the conference, tap on END button to disconnect. If the GAC2500 is the conference host, ending the conference will disconnect all the members from the conference. If the conference member hangs up the call, it will be disconnected from the conference but other parties in the conference will stay in the conference.

## SCHEDULE CONFERENCE

SCHEDULE feature allows the user to set a specific time to hold a conference in advance, with conference reminder and members.

Tap on  on desktop to access Schedule screen, the schedule page is shown below, including upcoming conferences and conferences that has been held:

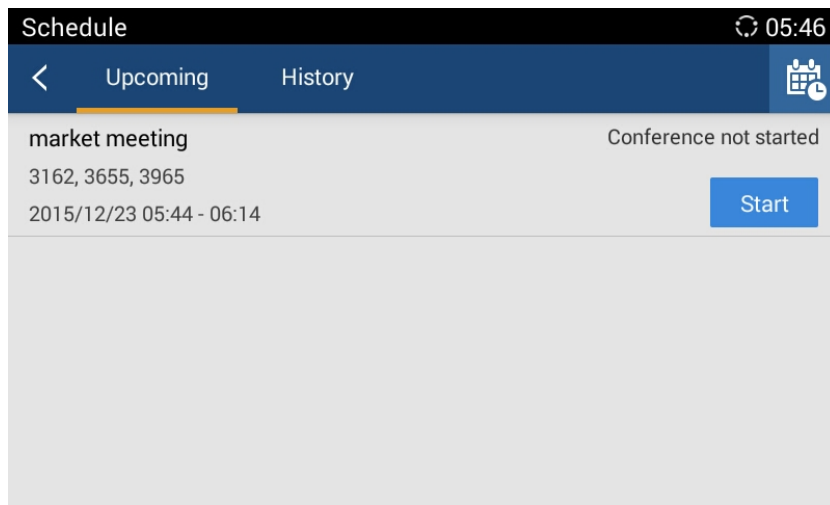

Figure 44 GAC2500 Schedule Screen

## VIEW CONFERENCE DETAILS

Users could view scheduled conference details after the current time. Select one conference and tap to

view conference details. Press  on the upper left corner or  to exit.

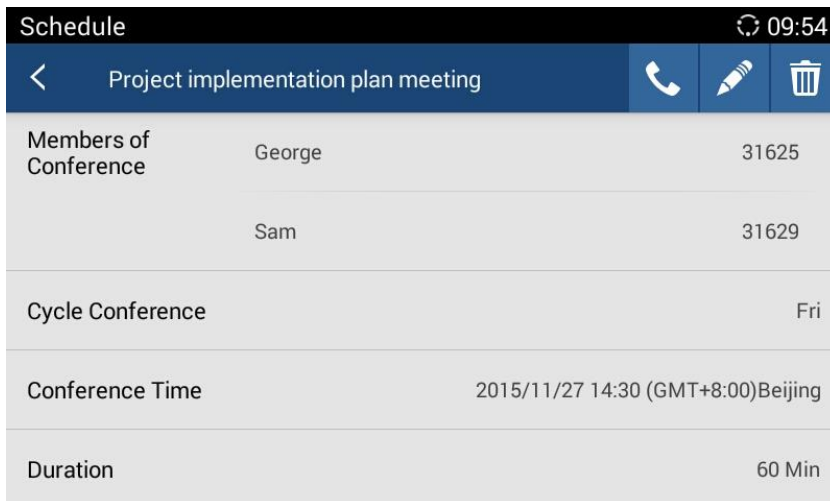



Figure 45 GAC2500 Conference Details Screen

## ADD SCHEDULED CONFERENCE

Follow the steps below to add a scheduled conference:

1. Tap on  on desktop to access Schedule screen.



2. Tap on  on the upper right corner to access "Add Conference" screen as below.

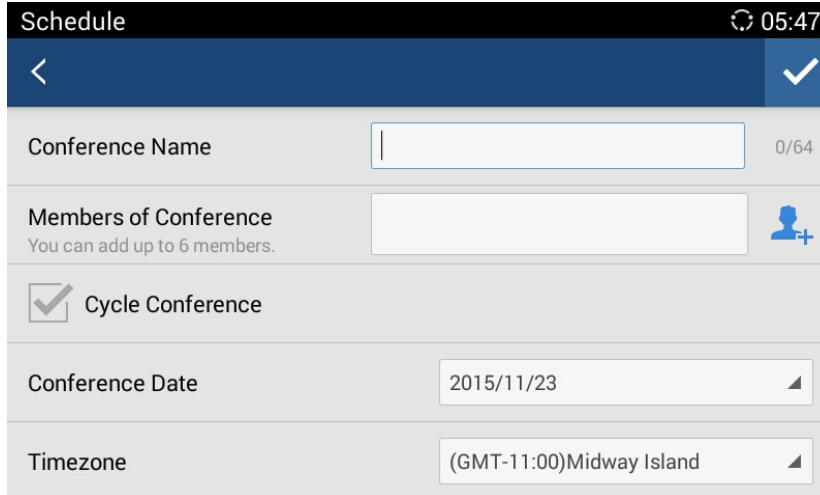

Figure 46 GAC2500 Add Conference Screen



3. Fill in conference name, members, start time, conference duration, etc.;
4. Tap on  to save the scheduled conference and go back to schedule screen.



Table 11 GAC2500 Add Conference Parameters

Parameters	Descriptions
<b>Conference Name</b>	Set the conference name to identify this conference.
<b>Members of Conference</b>	Click on button  to access the Add Member screen. You can add one member or a group of members. Tap on  on the upper right corner to save and go back to Add Conference screen. Up to 6 members can be added.
<b>Cycle Conference</b>	Set conference cycle.
<b>Conference Date</b>	Configure the date when the conference starts. It should not be earlier than the current date.
<b>Time Zone</b>	Configure conference time zone.
<b>Start Time</b>	Configure the time when the conference starts. It should not be earlier than the current time.
<b>Duration (Min)</b>	Configure conference duration.
<b>Reminder Time</b>	Configure whether to remind users in advance. A prompt dialog box will pop up on the GAC2500 screen before the conference starts.
<b>Auto Conference</b>	Configure whether to initiate conference when the conference time comes. If disabled, a prompt dialog box will pop up on the GAC2500 screen 10 minutes before the conference starts to remind users whether to start conference.

<b>Auto Answer For Conference Member</b>	Configure whether to answer the call from the conference member automatically. If the call is not from the conference member, it will not be answered automatically.
<b>Lock</b>	Users could lock/unlock the scheduled conference. Once locked, the other incoming calls will not be able to join conference. The conference screen will display the lock icon when the scheduled conference started, you can also disable this function, please refer to chapter <b>Conference Management</b> for more details.
<b>Auto Record</b>	Configure whether to record automatically once the conference started. If enabled, it will record when the conference starts (with active line).
<b>Enter Block</b>	Configure whether to block conference members when they enter conference. If enabled, conference members who auto answered will not hear others unless unblocked by the host.

## EDIT SCHEDULED CONFERENCE

Follow the steps below to edit scheduled conference:

1. Access conference schedule screen and select the conference entry you would like to edit.
2. Tap on  on the upper right corner to access edit screen.
3. Tap on  on the upper right corner to save changes and go back to schedule screen.

## RESCHEDULE CONFERENCE

If you want to reschedule the conference that has been held, please refer to steps in chapter **Edit Scheduled Conference** to edit conference again and save.

## DELETE SCHEDULED CONFERENCE

Follow the steps below to delete the existing scheduled conference:

1. Access Schedule screen;
2. Long press the conferences entry to access the edit screen as shown below:

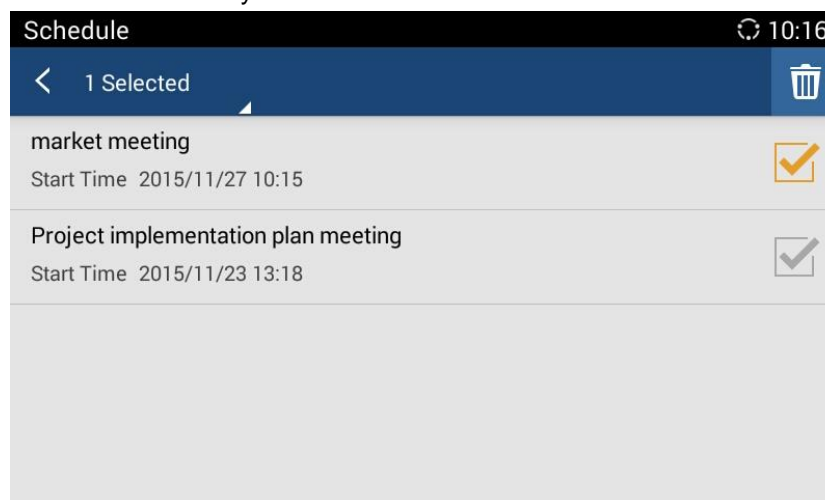



Figure 47 GAC2500 Delete Scheduled Conference Screen

3. Check the conference (s) you want to delete and tap on  on the upper right corner to delete.

## DELETE HISTORY CONFERENCE

You can see all scheduled conferences which has passed the scheduled time in "History" option, you can edit/delete/reschedule the conference here.

There are 2 ways to delete history conference.

- **Delete single conference entry.**

1. Access schedule screen and select the conference entry you would like to delete;

2. Slide left on screen as shown below and tap on  to delete conference.

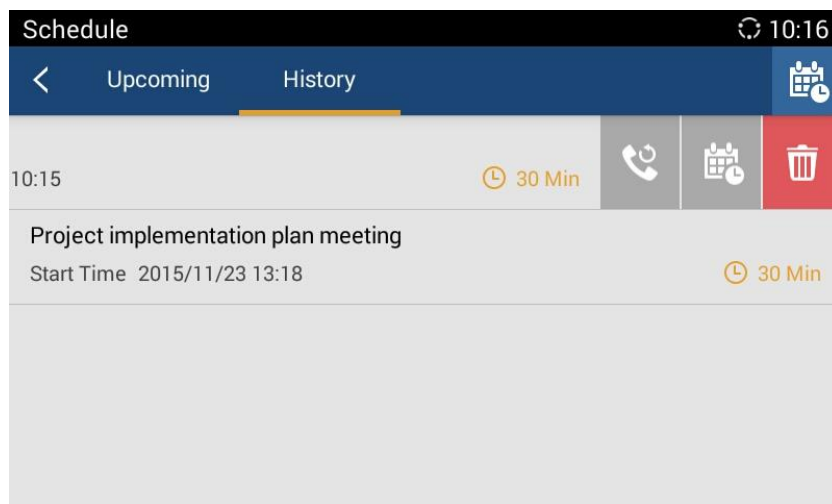

Figure 48 GAC2500 Delete History Conference Screen

- **Batch delete conference entries.**

1. Access Schedule screen;
2. Long press the conferences entry to access the edit screen as shown below:

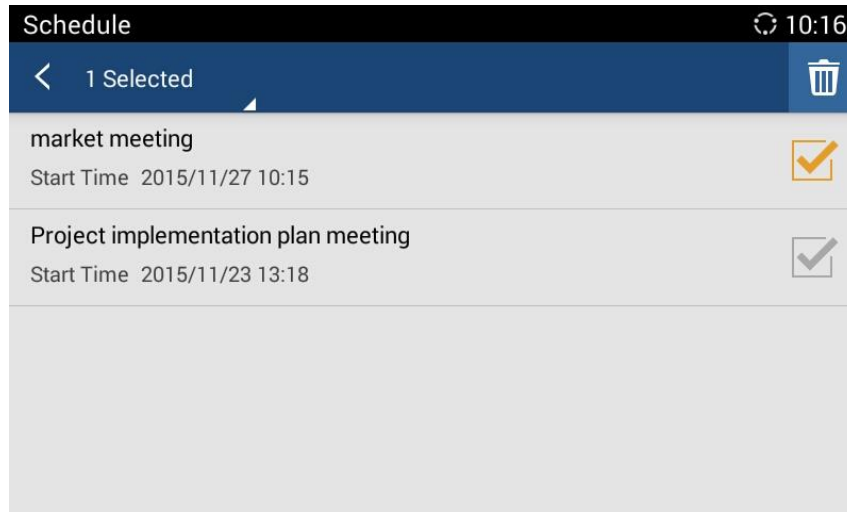



Figure 49 GAC2500 Batch Delete History Conference Screen

3. Check the conferences you want to delete and tap on  on the upper right corner to batch delete conferences.



**Note:**

If you edit a history conference, it will become a new scheduled conference after save.

---

## VOICEMAIL

When there is a new voicemail, voice mail icon  will show up as a notification in the status bar. Users could go to Settings->Advanced Settings->Account, or login the web UI->Settings->Account->General Settings ->Voice Mail UserID to configure the access number for the voicemail.

Follow the steps below to access voicemail:

1. Access the dial screen and input voicemail access number;
2. Tap on  on the dial screen to dial into the voicemail box;
3. Follow the Interactive Voice Response (IVR) for the message retrieval process.

Users could also tap on  to access the voicemail box. The number of new voicemail messages will be shown on the voice mail app icon as well. See figure below.

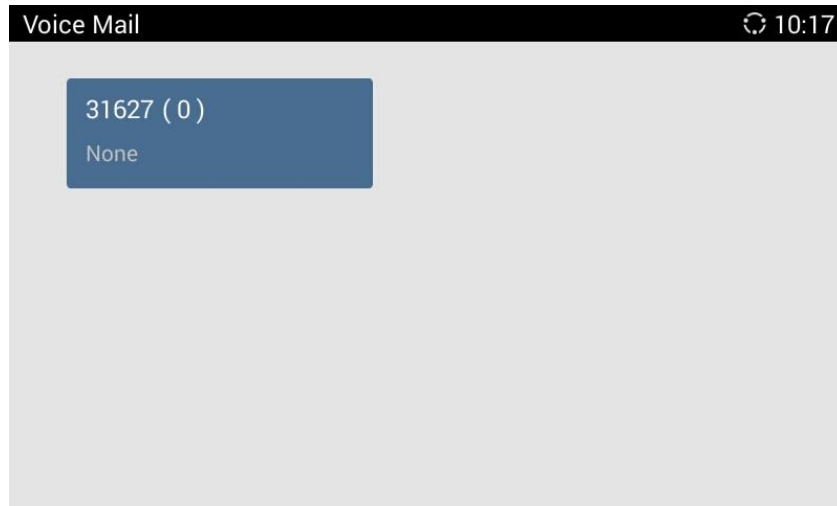

**Figure 50 GAC2500 Voice Mail Application**

## APPLICATIONS

GAC2500 provides built-in applications such as like Contacts, Call History, File Manager, Browser and etc.

Users could also download the apps from GS market to install on the GAC2500.

### CONTACTS

GAC2500 Contacts app helps users to easily store and manage phone number and contact information. Users can add contacts on the GAC2500 or import contacts from external devices as well as download from a server.

On the GAC2500 home screen, you can see local Contacts and LDAP Contacts.

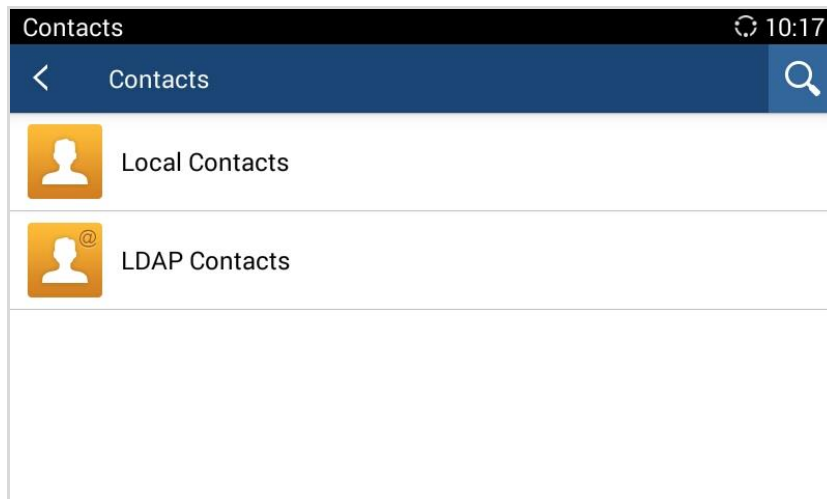



Figure 51 GAC2500 Contacts Screen

### LOCAL CONTACTS

The Local Contacts screen shows as follows:



Figure 52 GAC2500 Local Contacts Screen

- **Back.** Back to the previous page.
- **Contacts.** Display all contacts.
- **Groups.** View groups. Select one group to view group details.
- **Blacklist.** Display blacklist.
- **Call.** Tap  on the contact you would like to call.
- **Add Contact.** Tap to access New Contact screen. Fill in contact information and save.
- **Search Contact.** Tap to access Search Contact screen.
- **More.** Tap on  to export/import/download Contacts, view storage status or sort Contacts.
- **Contact Details.** Select one contact to view contact details.

## ADD CONTACT

### ADD SINGLE CONTACT

Follow the steps below to add one single contact.

1. On the Contacts screen, tap on the button  to access New Contact screen;

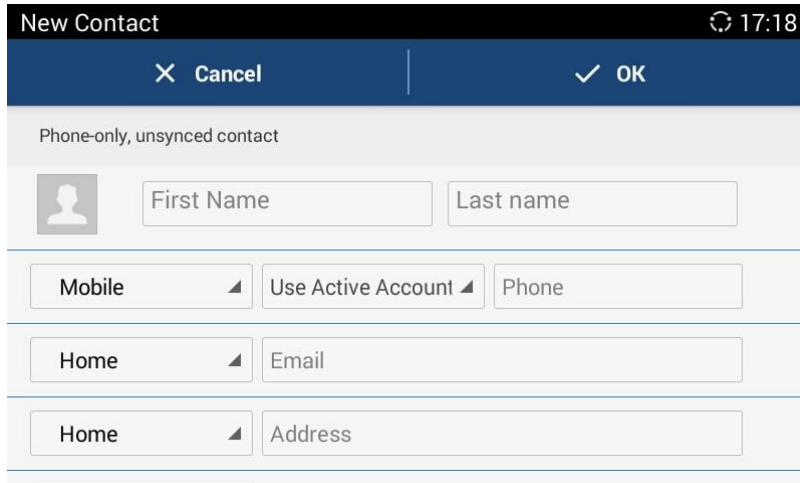



Figure 53 GAC2500 Add New Contact Screen

2. Enter contact information. Choose the account on the left of the “Phone” field to dial out this number;
3. Click "OK" to save the contact information.

## BATCH IMPORT CONTACTS

Import function allows users to batch import contacts. The phonebook with compatible format needs to be saved to the storage devices like SD card/USB flash drive and plugged into the GAC2500.

1. On the Contacts screen, tap on the MENU key  on Contacts screen and select "Import" to access Import Contacts screen;
2. Configure parameters and select the path to save the imported file;
3. Click "OK" to save the contact information.

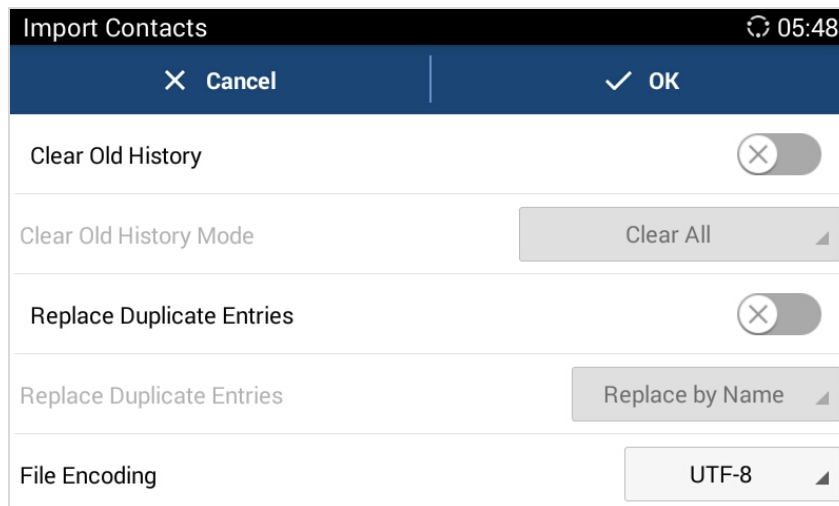

Figure 54 GAC2500 Import Contacts Parameters Screen



**Table 10 GAC2500 Import Contacts Parameters**

Parameters	Descriptions
<b>Clear Old History</b>	If enabled, the previous contact records will be deleted when a new phonebook file is loaded into the phone. If disabled, both the old contacts and new contacts will be kept in the GAC2500.
<b>Clear Old History Mode</b>	Configures whether clear all contacts or reserve local contacts when clear old list. The default setting is "Clear All".
<b>Replace Duplicate Entries</b>	If enabled, when the phonebook file is imported to the phone, the duplicated entries will be removed. If disabled, both the old contacts and new contacts will be kept in the GAC2500.
<b>Replace Duplicate Entries Mode</b>	You can replace duplicate entries by name or number.
<b>File Encoding</b>	Select the encoding format for XML contact file.
<b>File Type</b>	Select the file format for phonebook file import. The device supports xml, csv and VCard format.
<b>Select The File</b>	Select file from storage device plugged into the GAC2500.

## DOWNLOAD CONTACTS

GAC2500 supports downloading phonebook from the file server to batch add contacts. The default file name the GAC2500 looks for is "phonebook.xml". The phonebook XML file should be placed under the file server directory for the GAC2500 to retrieve. The GAC2500 supports VCard/xml/csv file format.

1. On the Contacts screen, tap on the MENU key  and select "Download" to bring up the Download Contacts screen;

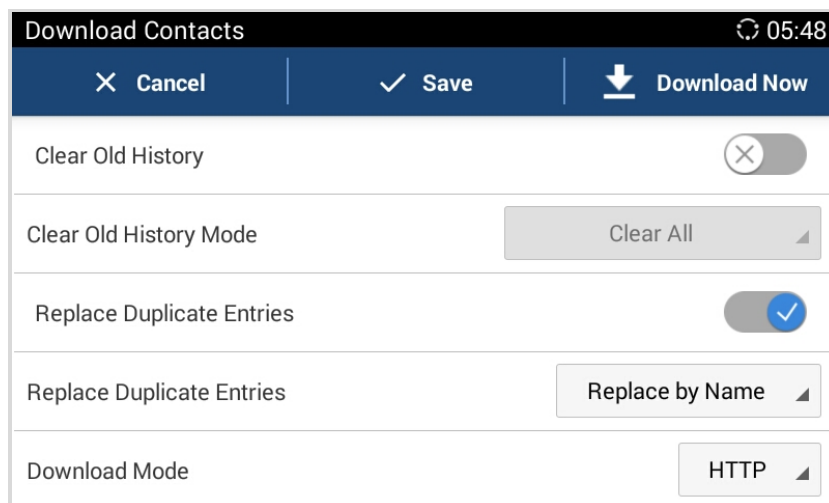
**Figure 55 GAC2500 Download Contacts Screen**

2. Configure parameters and select the path to save the file;

3. Tap on the "OK" key to save the contact information.

**Table 11 GAC2500 Download Contacts Parameters**

Parameters	Descriptions
<b>Clear Old History</b>	If enabled, the previous contact records will be deleted when a new phonebook file is loaded into the phone. If disabled, both the old contacts and new contacts will be kept in the GAC2500.
<b>Clear Old History Mode</b>	Configures whether clear all contacts or reserve local contacts when clear old list. The default setting is to "Clear All".
<b>Replace Duplicate Entries</b>	If enabled, when the phonebook file is downloaded to the GAC2500, the duplicated entries will be removed. If disabled, both the old contacts and new contacts will be kept in the GAC2500.
<b>Replace Duplicate Entries Mode</b>	You can replace duplicate entries by name or number.
<b>Download Mode</b>	Select the phonebook download mode from TFTP, HTTP or HTTPS.
<b>File Encoding</b>	Select the encoding format for the XML contact file.
<b>Time Intervals</b>	Configure the time interval to download XML contact file.
<b>Download Server</b>	Fill in the server URL or IP address to download the XML contact file to the device.

## SEARCH CONTACTS

GAC2500 supports Search function, users could tap on  icon on the Contacts page and input the keyword to search in the pop-up dialog. GAC2500 will automatically display contacts items related to the search info. Fuzzy search and precise search are both supportive.

## MANAGE CONTACTS

### DELETE CONTACT

1. Long press the contact you would like to delete to access edit screen;
2. Check the contact, or click the button on the upper left corner of the toolbar for quick operation. "Select All" indicates check all select entries while "Cancel All" indicates uncheck all selected entries;
3. The digit on the upper right corner indicates how many contacts you have selected, tap on  to delete contacts you selected.

### EXPORT CONTACTS

The GAC2500 supports exporting phonebook as VCard/xml/csv files and save the files to other external storage devices.

1. Press the MENU key  on Contacts screen to bring up the Export Contacts screen.

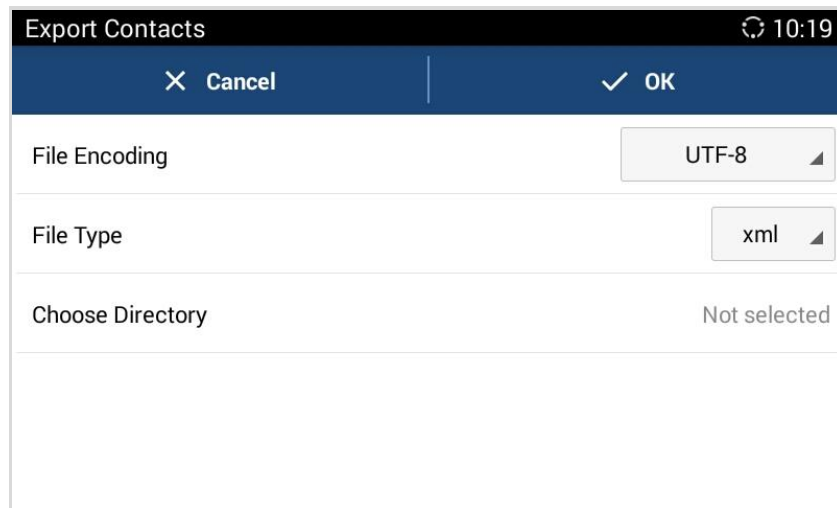

Figure 56 GAC2500 Export Contacts Screen

2. Configure parameters as shown in table below and select the directory to save the exported file.
3. Tap on the "OK" key to export the file.

Table 12 GAC2500 Export Contacts Parameters

Parameters	Descriptions
<b>File Encoding</b>	Select the encoding format for XML contact file.
<b>File Type</b>	Select the file format for phonebook file export. The device supports xml, csv ,vcard.
<b>Choose Directory</b>	Select directory to save file.

## SEND CONTACTS

1. Long press the contact you would send to enable edit screen;
2. Check the contact you want to send;
3. Choose the way to send contact. If Bluetooth Device Chooser has been enabled, users could send the contact to the paired user via the Bluetooth.

## CONTACTS STORAGE STATUS

Tap on  on the Contacts page to view the contacts storage. You can store up to 2000 entries.

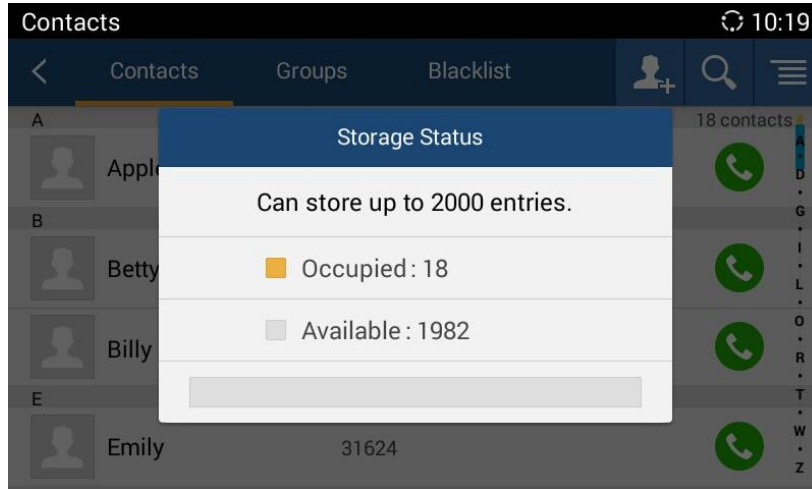

Figure 57 GAC2500 Contacts Storage Status Screen



**Note:**

The contacts synchronize with account do not occupy the storage space.

## ADD GOOGLE ACCOUNT

Account allows users to add vast number of 3rd party Android applications (including Google, Lync, Skype, company, Email, and etc.).Users can also sync GAC2500 via Google Play account, corporate account or Email.

Tap "Add Account" button to add new account according to the installation wizard.

The following steps demonstrate how to add a Google account.

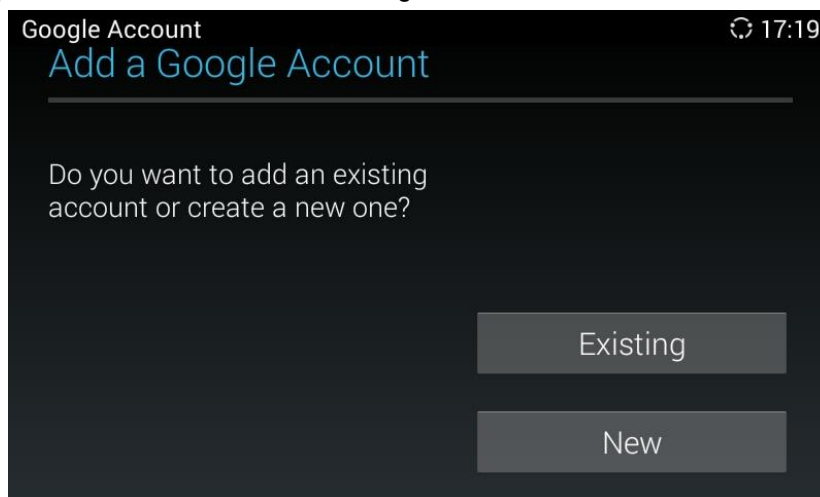

Figure 58 GAC2500 Add Google Account - Wizard 1

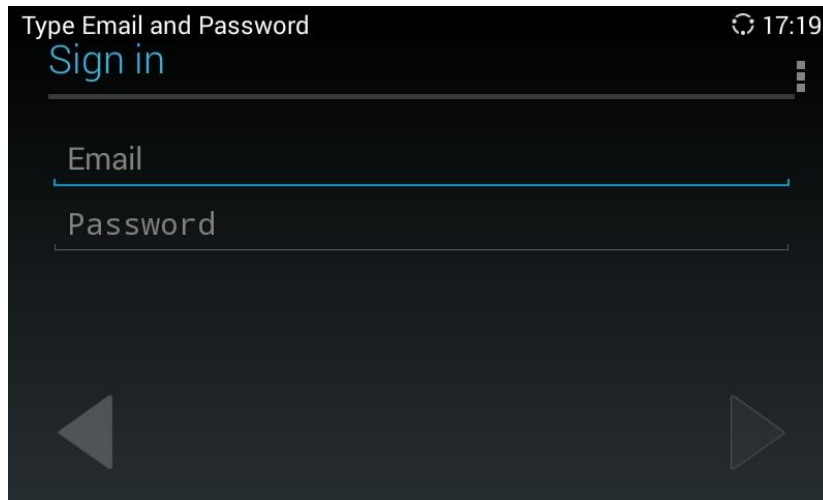

Figure 59 GAC2500 Add Google Account - Wizard 2

## GROUPS

Users could divide contacts into different groups with specific names. Tap on one group entry to view group details.



Figure 60 GAC2500 Groups Screen

## ADD NEW GROUP

There are 2 ways to add group members.

- Add the contact to the group when editing or adding a new contact.
- Select the contact you would to add to this group on Groups page when adding or editing a new group.

Follow the steps below to create a new group:

1. Tap on  on the Groups page as shown below;

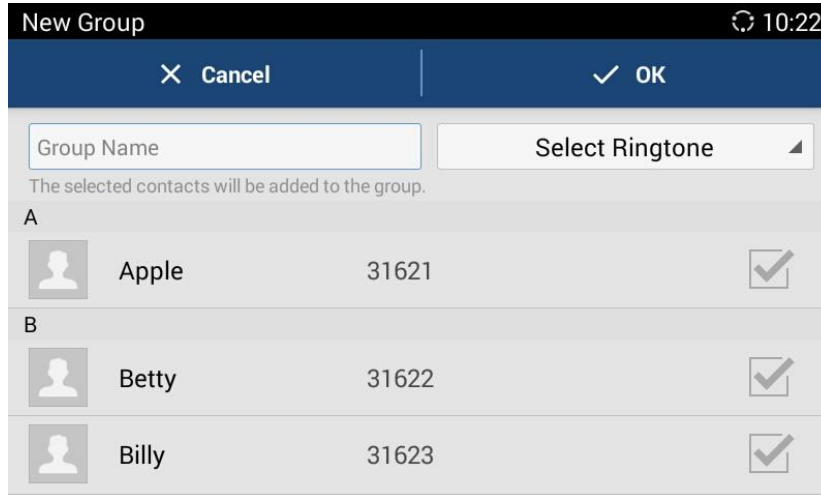

Figure 61 GAC2500 Add Group Screen

2. Input the group info and click "OK" to save group.



**Note:**

The priority of ringtones from high to low is "Custom", "Group", "Account" and "Default". If one group has set the custom ring for its contacts, the phone will ring the custom ringtone other than other group ringtones.

## CALL GROUPS



1. Tap on  on the upper right corner on Groups screen to access screen as shown below:

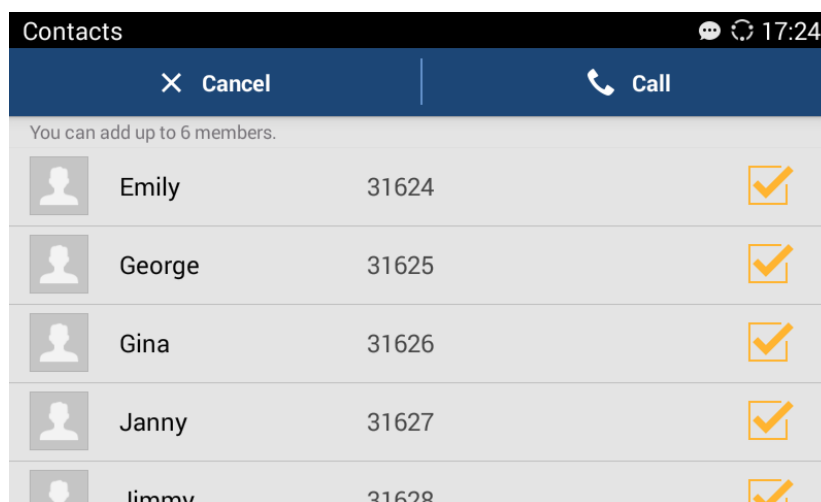

Figure 62 GAC2500 Dial Group Members Screen

2. Check group member (s) you want to call;
3. Tap on the CALL button to dial out.

## DELETE GROUP

Follow the steps below to delete groups.

1. Long press the group entry you want to delete, the screen is shown below:

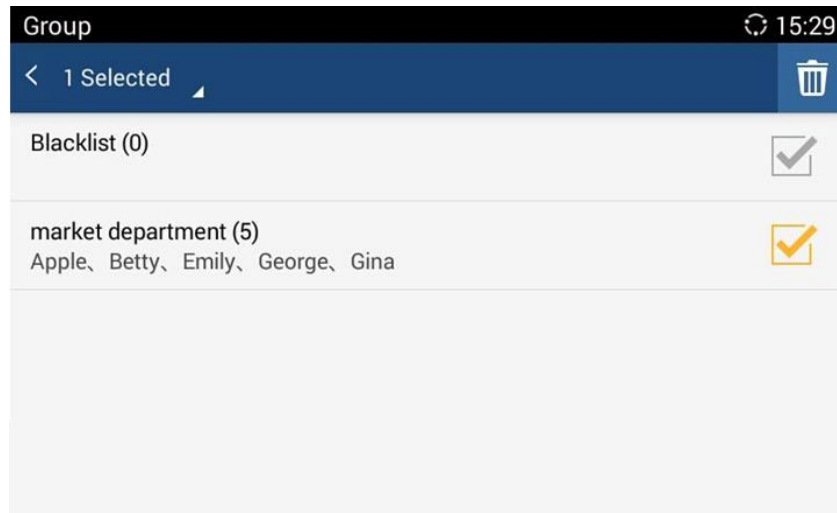



Figure 63 GAC2500 Edit Groups Screen

2. Check to select the group (s) you would like to delete;
3. Tap on  on the upper right corner to delete.

## BLACKLIST

Blacklist helps users to block calls from blacklist at the same time does not affect normally answering other incoming calls.

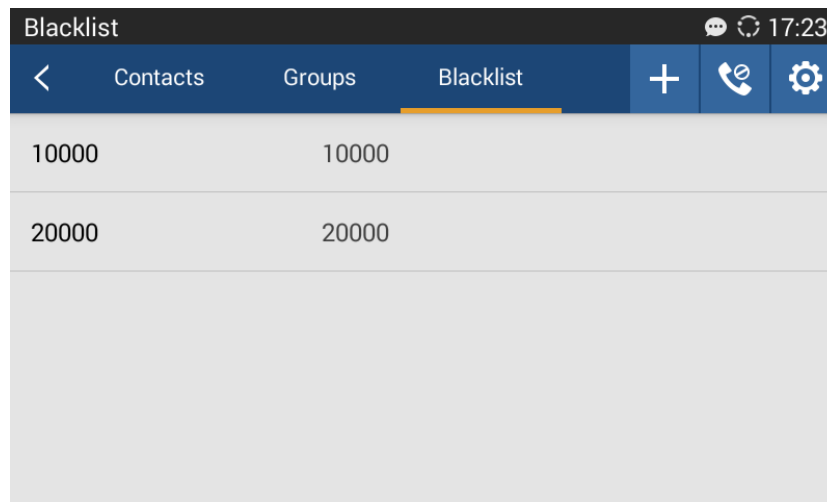

Figure 64 GAC2500 Blacklist Screen



: Display blocks history.



: Tap to add number to blacklist. There are 3 ways to add number: Manually add, Add from Contacts,

Add from Call History. Select one way and tap on "OK" to add the corresponding number to blacklist. Long press one blacklist log to enter the editing mode to edit or delete the selected contact (s). Users could edit the blacklist entry when only one is selected.

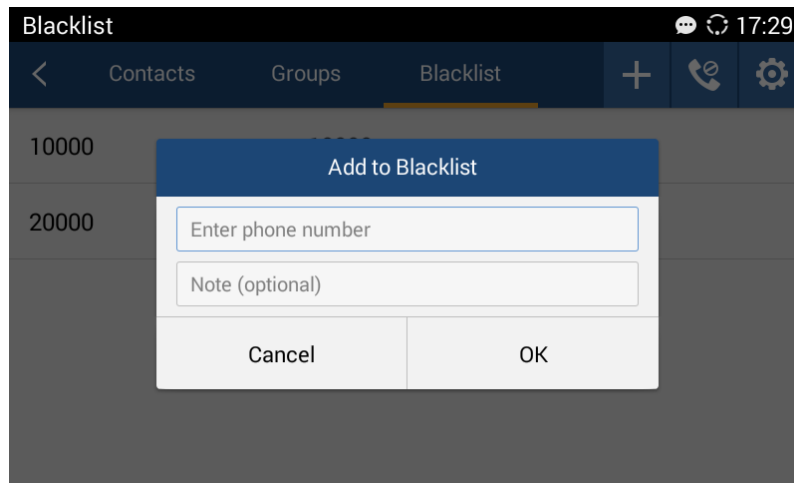

Figure 65 GAC2500 Manual Add Blacklist Screen



: Blacklist Settings.

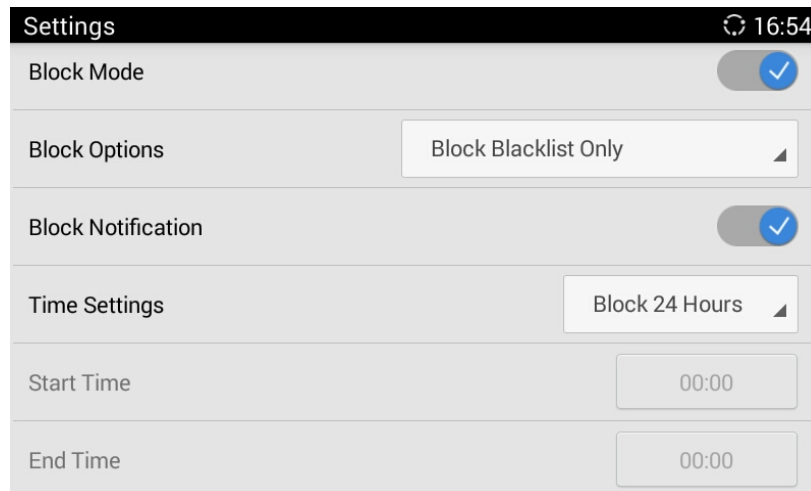



Figure 66 GAC2500 Blacklist Settings Screen

Table 13 GAC2500 Blacklist Settings Parameters

Parameters	Specification
<b>DND Mode</b>	Turn on/off DND mode. Once it's turned on, the phone would reject all incoming calls.
<b>Block Mode</b>	Turn on/off Block Mode. Once it's turned on, the incoming calls from the numbers in the blacklist will be rejected.
<b>Block Options</b>	Set the types of incoming calls. This option is valid once the Block Mode is turned on.



<p><b>Block Notification</b></p>	<p>Set up whether to notify user after blocked calls. Once it's turned on, the block icon  will be displayed in the status bar after the device blocked calls. Users could go to the notification bar to view details.</p>
<p><b>Time Settings</b></p>	<p>Set up the block schedule.</p>

## LDAP

GAC2500 supports LDAP. Tap on LDAP Contacts to access the main interface as shown below:

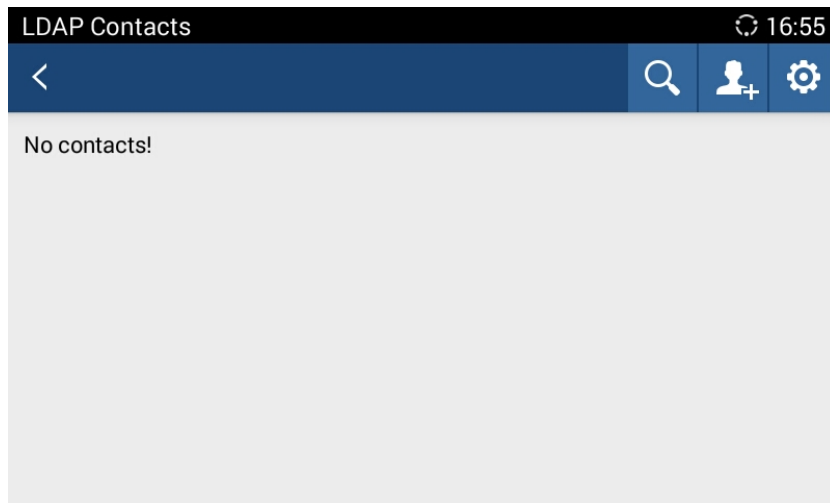

Figure 67 GAC2500 LDAP Book Screen

Tap on  on the upper right corner or login the Web page to configure it. (Maintenance ->LDAP Book).



Figure 68 GAC2500 LDAP Settings

**Table 14 GAC2500 LDAP Book Parameters**

Parameters	Descriptions
<b>Server Address</b>	LDAP server address, users could input IP address or domain name.
<b>Port</b>	Set up the port number of LDAP server.
<b>Base DN</b>	Set up the base DN to inquire on the serve ,namely under which directory to inquire contacts. I.e., dc=grandstream, dc=com ou=Boston, dc=grandstream, dc=com
<b>User Name</b>	Set up the username to login LDAP server. Some LDAP servers support anonymous login without username.
<b>Password</b>	Set up the password to login LDAP server. If the LDAP server support anonymous, users could login without password.
<b>LDAP Name Attributes</b>	Set up the name attribute of each record returned from LDAP search. It allows users to configure multiple name attribute separated by spaces. i.e., gn cn sn description
<b>LDAP Attributes</b> <b>Number</b>	Set up the number attribute of each record returned from LDAP search. It allows users to configure multiple number attribute separated by spaces. i.e., telephoneNumber telephoneNumber Mobile
<b>LDAP Mail Attributes</b>	Set up the mail attribute of each record returned from LDAP search. It allows users to configure multiple mail attribute separated by spaces. i.e., Mail mail mailbox
<b>LDAP Name Filter</b>	Set up the filter when configure name inquiry.i.e., (!(telephoneNumber=%)(Mobile=%) return all "telephoneNumber" or contacts with specified filter value in "Mobile" field; (&(telephoneNumber=%) (cn=*)) return all contacts with specified filter value with "cn" field in "telephoneNumber".
<b>LDAP Number Filter</b>	Set up the filter when configure number inquiry.i.e., (!(telephoneNumber=%)(Mobile=%) return all "telephoneNumber" or contacts with specified filter value in "Mobile" field; (&(telephoneNumber=%) (cn=*)) return all contacts with specified filter value and the set "cn" field in "telephoneNumber".
<b>LDAP Mail Filter</b>	Set up the filter when configure mail inquiry.i.e., (!(mail=%)(mailBox=%)) return all contacts with specified filter value in "Mail" or "Mailbox"; (!(mail=%)) return all contacts without specified filter value in "Mail"; (&(mail=%) (cn=*)) return all contacts with specified filter value and the set "cn" field in "mail".
<b>LDAP Displaying Name Attributes</b>	Display onscreen name attribute, up to three attributes.i.e., %cn %sn %telephoneNumber
<b>Max Hits</b>	Set up the max hit return to the LDAP server. If set to "0", the server will return all searched results. The default setting is "50".
<b>Search Timeout (ms)</b>	Set up the search timeout return after inputting search info. The default setting is "4000".
<b>LDAP Lookup For Dial</b>	Set up whether to apply LDAP lookup for dial. The default setting is "No".

<b>LDAP Lookup For Incoming Call</b>	Set up whether to apply LDAP lookup for incoming call. The default setting is "No".
--------------------------------------	---

Once configured, you can tap on Search button  to input digits or name to search LDAP contact as shown below.



Figure 69 GAC2500 Web GUI Maintenance - LDAP Book



: dial out.



: Add the LDAP contact to local Contacts.

Follow the steps below to batch add LDAP contacts:

1. Search LDAP contacts;

2. Tap on  to access add contact screen as shown below:

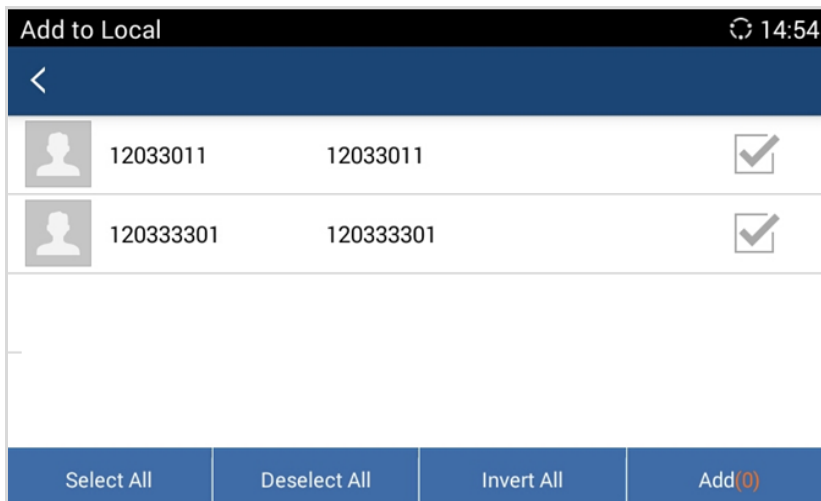

Figure 70 GAC2500 Add LDAP Contact To Local

3. Check contacts entries to add contacts to local.

## CALL HISTORY

Call History provides users access to phone's recent call records. The user can view all records, or select different categories for incoming calls, outgoing calls, missed call and conference.

To access Call History, go to Home screen->APPLICATIONS->

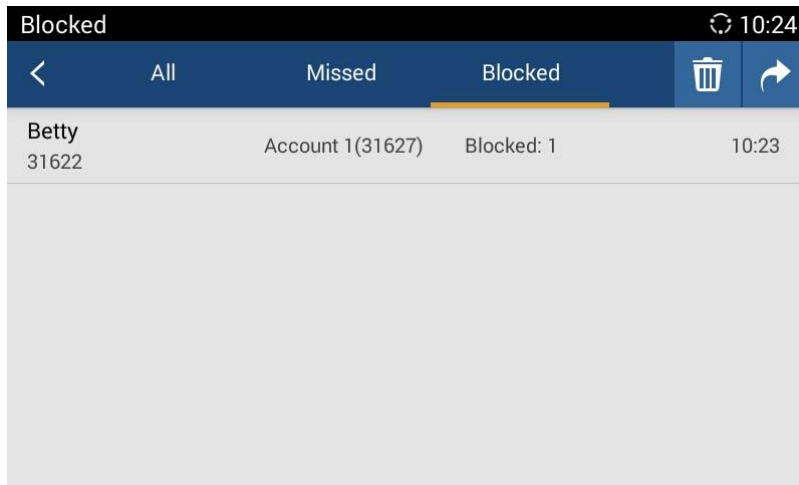



Figure 71 GAC2500 Call History Screen

Click on a record in the call history and press  to dial out this number directly. Tap one history entry to view call details for this number.

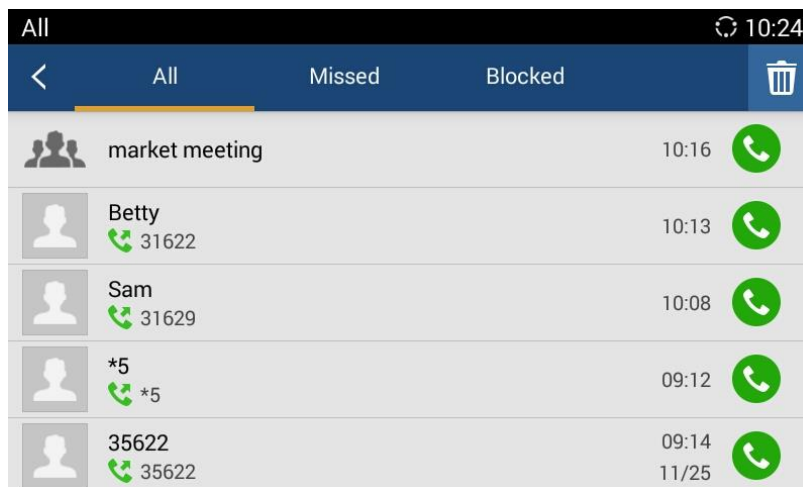



Figure 72 GAC2500 Call History Details



**Note:**

Call history displays all BlueJeans™ conference call history as well. Tap on  to dial out directly and there is no need to input the password again. However, if the conference doesn't exist or the password has been changed, the re-dial will fail.

**ADD CONTACT FROM CALL HISTORY**

1. Access Call History screen;
2. Select one call history entry to access details screen;
3. Tap  on the upper right corner to access Add Contact screen;

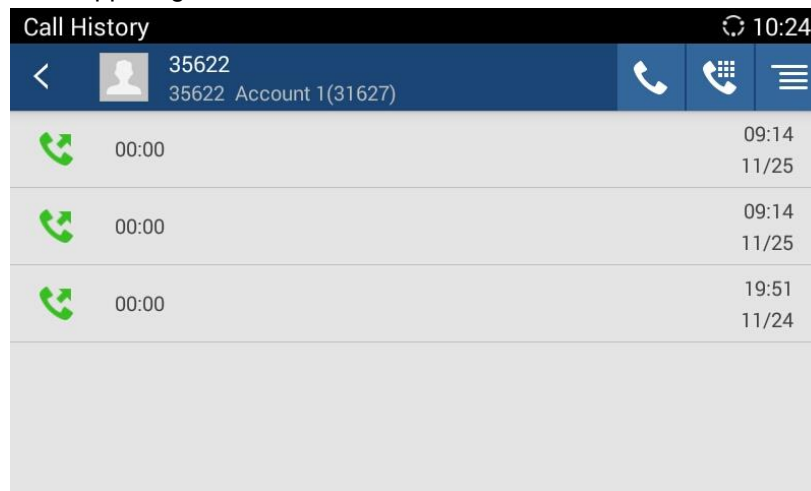



Figure 73 GAC2500 Add Contact screen

4. Confirm to add contacts.

**DELETE CALL HISTORY**

1. Long press the call history entry you want to delete to access editing mode;
2. Check the entry and tap on , click "OK" to delete.

**SCHEDULE CONFERENCE VIA CALL HISTORY**

1. Select one call history entry you would like to add to scheduled conference;

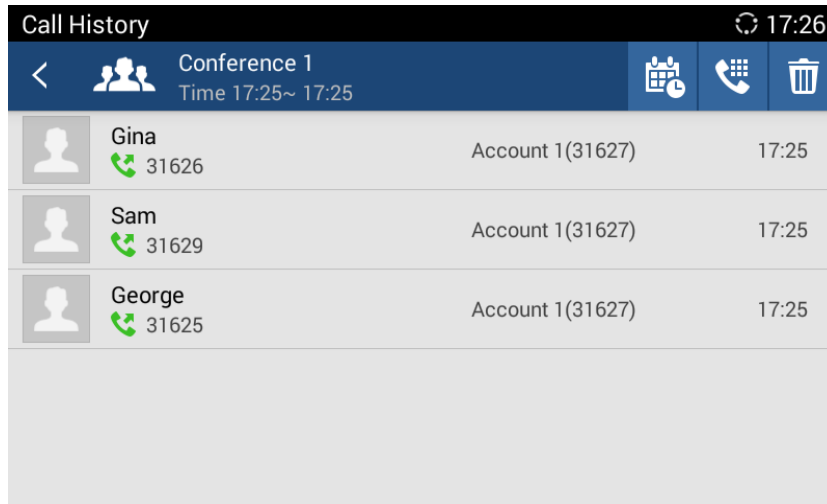



Figure 74 GAC2500 Conference Call History Screen

2. Tap  on the upper right corner to access schedule screen;
3. Fill in information and tap on  to save.



**Note:**

If the conference members are more than 6 people, you will enter the members select screen to check members first.

### INTERCEPTED HISTORY

When the incoming call is from contact in blacklist, the GAC2500 will reject it automatically. The screen is as shown below.

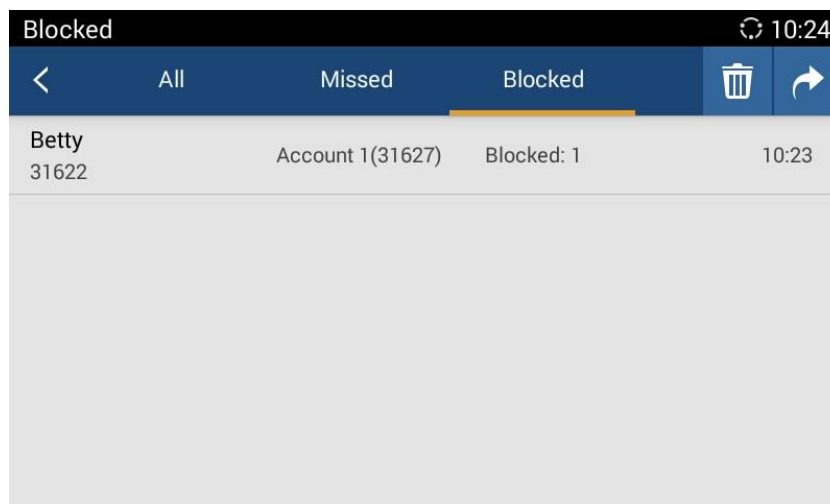

Figure 75 GAC2500 Intercepted History Screen





: Empty intercepted history.



: Restore to be the contact.

## MPK

User could login the Web page and go to Advanced Settings->MPK LCD Settings or tap on Menu—MPK to configure it.

1. Open MPK, tap on  on the upper right corner to access Number List page. Tap on  to add number. As shown in figure 76.

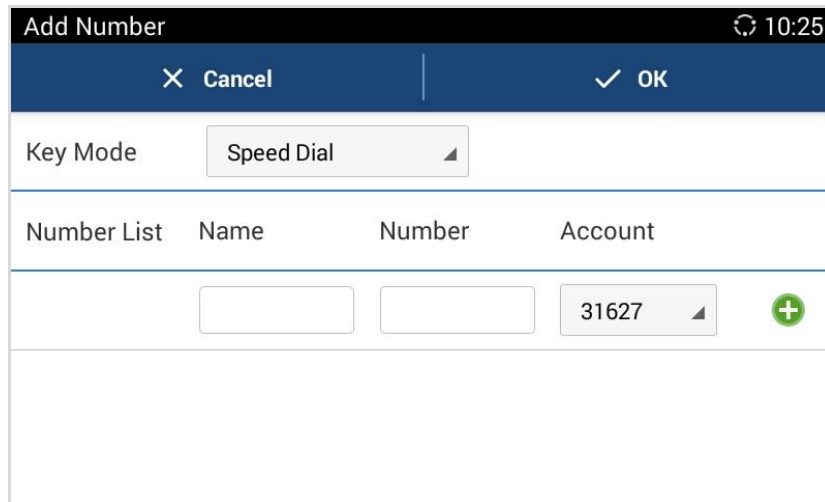



Number List	Name	Number	Account
			31627  

Figure 76 GAC2500 Add MPK Number



Name	Number	Account
Apple	31621	Speed Dial
Betty	31622	Busy Lamp Field (BLF)
Billy	31623	Busy Lamp Field (BLF)
Emily	31624	Busy Lamp Field (BLF)
George	31625	Busy Lamp Field (BLF)

Figure 77 GAC2500 MPK Number List

- Users could also tap on  to add number directly from Contacts. See figure below.

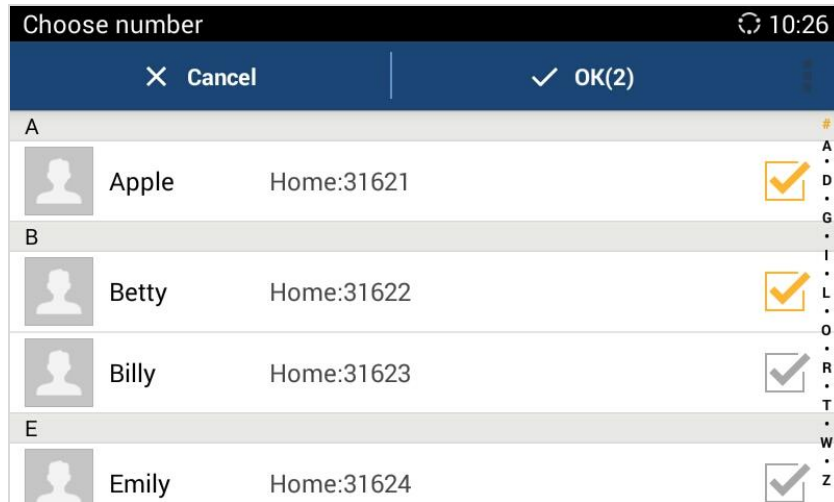

Figure 78 GAC2500 Add Number from Contacts

- The MPK screen is shown in figure 79 after added numbers.

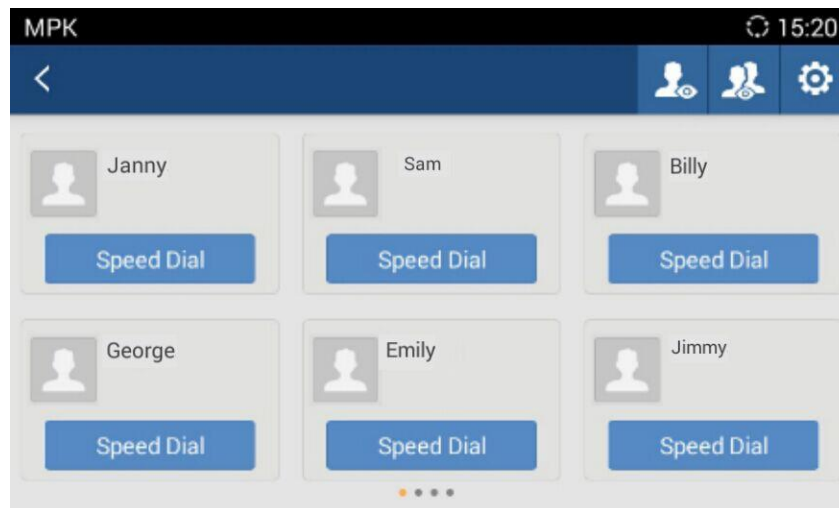



Figure 79 GAC2500 MPK Number Screen

### EVENTR LIST URL

The Event List URI in MPK list, it requires server support. Users should firstly configure a Event List URI including expanded list on the server (e.g.: [BLF1006@myserver.com](mailto:BLF1006@myserver.com)) and fill in URI without a domain name (e.g.: BLF1006).

- Open MPK, tap on  on the upper right corner to access URL Settings page. Tap on  to screen as shown in figure 80.



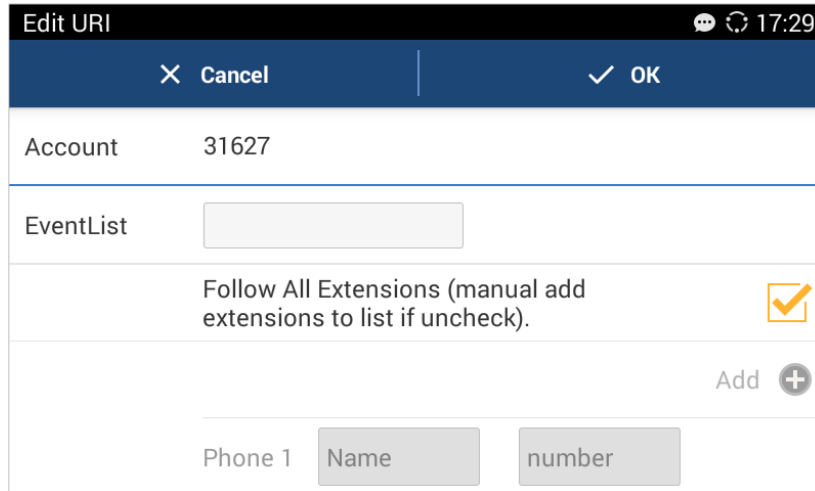



Figure 80 GAC2500 MPK Number Screen

2. Fill in information and save.

### MPK SETTINGS

Tap on  on the upper right corner on MPK screen to access Settings screen as shown below:

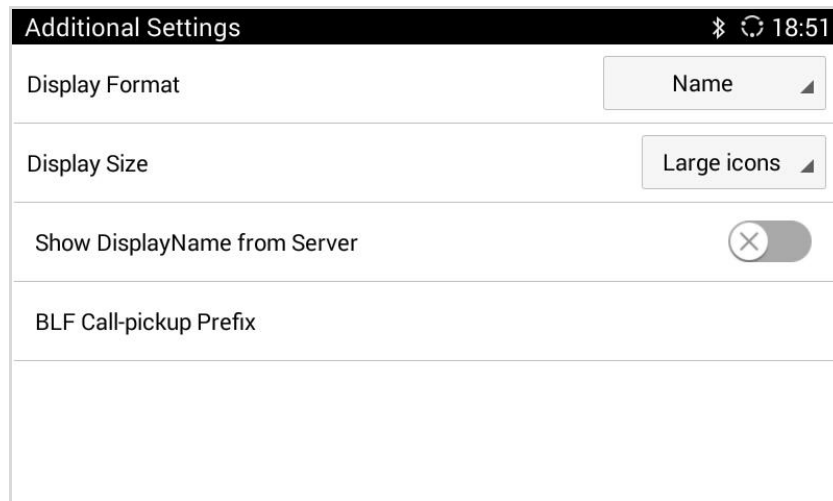

Figure 81 GAC2500 MPK Settings Screen

Table 15 GAC2500 MPK Settings Parameters

Parameters	Descriptions
<b>Display Format</b>	Configures the display format for the MPK. The default setting is "Name".
<b>Display Size</b>	Configures the display size for the MPK. The default setting is "large icons".
<b>Show Display Name from Server</b>	If selected, the display name on the server will replace the name users configured. The default is "No".
<b>BLF Call-pickup Prefix</b>	If configured, the phone will add the prefix each time using MPK button to answer the call. The default setting of each account is "***".

## NOTICES

Users could receive SIP messages and set up reject calls in Notices function. The Notices page is as shown below:

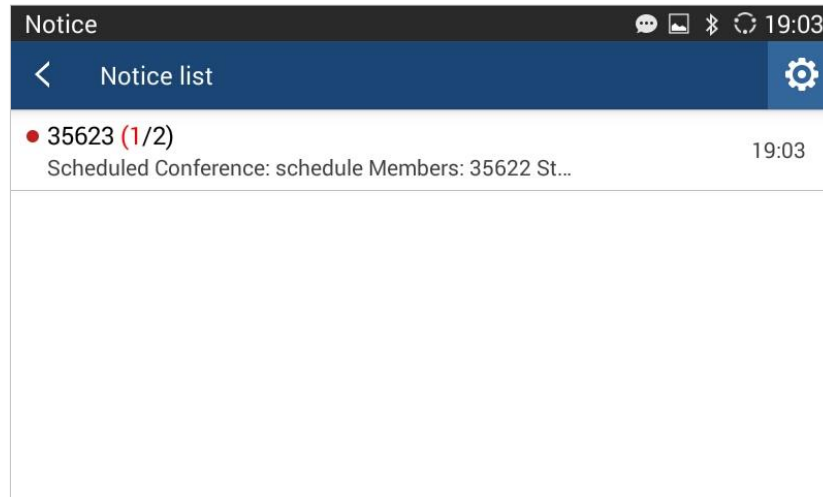

Figure 82 GAC2500 Notices Screen

## VIEW NOTICES

The Notices page displays notices list, the notices are classified by contacts name or phone number and sorted by the time when you received notices. Tap on one notice entry to view details.

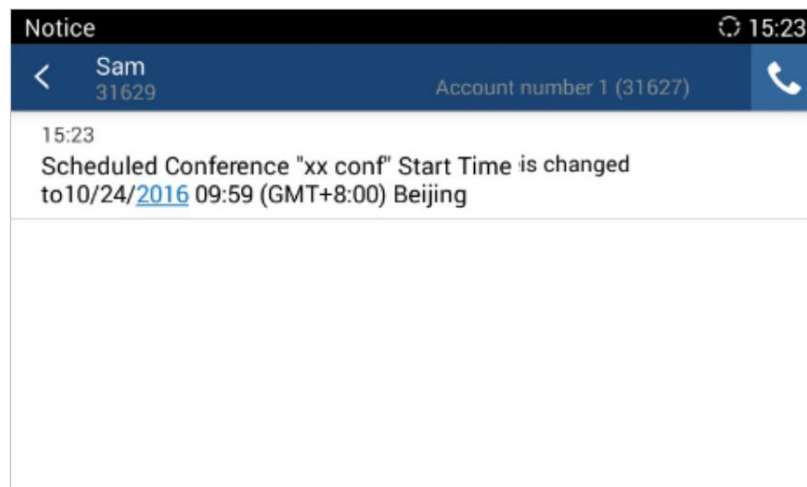



Figure 83 GAC2500 View Notices

## DELETE NOTICES

1. Long press one notice entry to access edit screen;
2. Check the notice (s) you want to delete and tap on  to delete.

## NOTICES SETTINGS

If enable "Allow Reminder", a warning will be sounded and you'll see notification on the status bar when receiving a notice; If enable "Quick Reply", a quick reply will be sent when the incoming call is rejected.

1. Tap on  on the upper right corner on Notices page to access Settings screen;

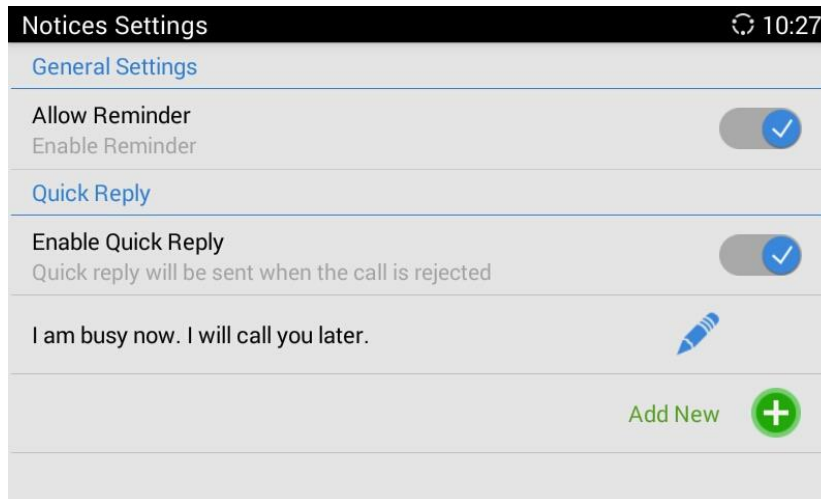

Figure 84 GAC2500 Notices Setting Screen

2. Enable quick reply and add reply content;
3. When there is an incoming call, the screen is as shown below:

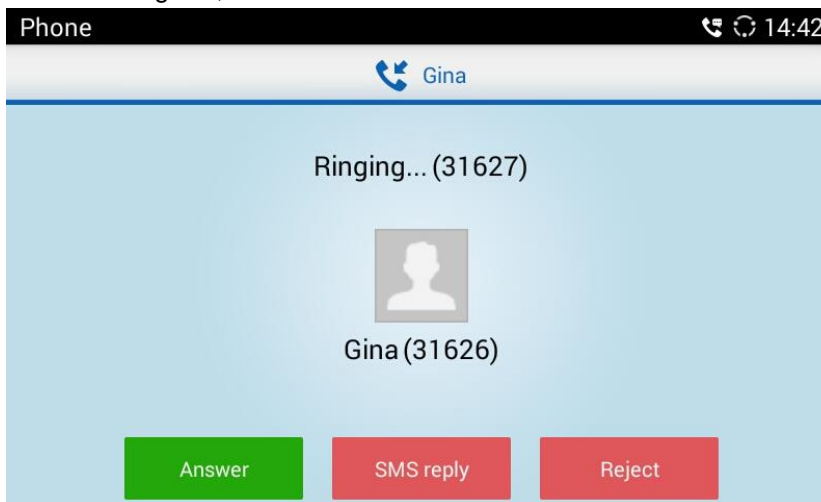

Figure 85 GAC2500 Incoming Call Screen



4. Tap on "SMS Reply";
5. Select one reply to send, the call will be rejected and the caller will receive the message.

## FILE MANAGER

File Manager allows users to delete, move, copy, paste, send, rename files (including files on storage device such as USB flash drive), and query file properties on the GAC2500.

## COPY FILE

To copy the file from the GAC2500 to USB storage device:

1. Insert USB/SD storage device into USB port on the GAC2500. It will take a few seconds for the GAC2500 to prepare the connection;
2. The USB storage icon will show on the status bar;
3. Go to Home screen, find the application File Manager;
4. Open the target folder;
5. Long press the file to select;
6. Tap on  on the upper right corner to copy file and press  to go back to the upper level directory;
7. Select target storage device and go to the directory where the file will be pasted to paste the file.

## SEND FILE

The first 5 steps are the same as the ones in Copy File.

6. Tap on  on the upper right corner select "Send" option;
7. Select target location and confirm to send file.



### Note:

If the user needs to send the file via Bluetooth, enable and connect Bluetooth device first. Otherwise, the interface will be redirected to the corresponding setting page to configure.



---

## DELETE FILE

The first 5 steps are the same as the ones in Copy File.

6. Tap on  on the upper right corner, a dialog will pop up for users to confirm whether to delete the file or not.
7. Press the "OK" key to delete the file successfully.

## RENAME FILE

1. Go to Home screen, find the application File Manager.
2. Open the target folder and select the file.
3. Press MENU key  on the upper right corner and select "Rename".
4. Input the new file name in the pop-up dialog and press the "OK" key to save, tap on "Cancel" or press  to cancel.

## RECORDER

Users could record conference, institution and personal notes via GAC2500 Recorder conveniently. There is no time limit to recording time and the larger the available storage capacity is, the longer the recording time is. Users could also find the recording file in the recorder and listen to it.

Long press the recording files to access editing interface, tap on the MENU key  to make other operations to recording files like export, rename, and lock/unlock.





**Note:**

If the USB storage is where recordings are written, the recording capacity depends on the USB storage space.

---

## NORMAL RECORDER

1. Tap on  on the upper right corner to access recording interface, Tap on  to initiate recording;

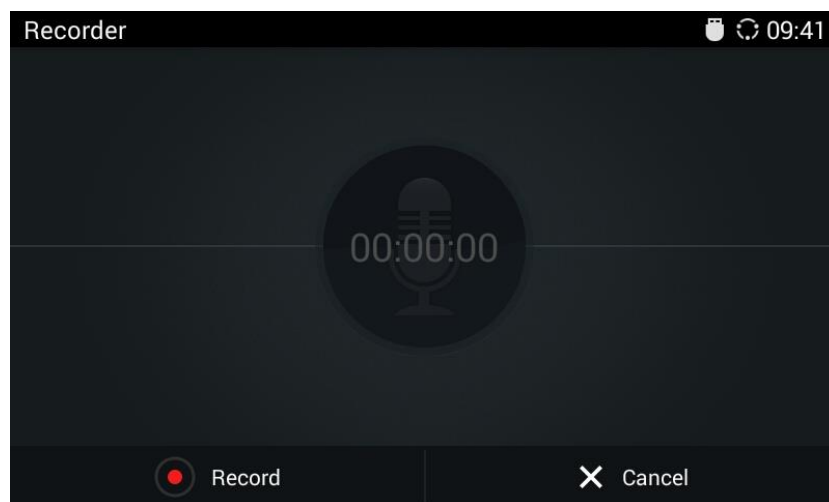

Figure 86 GAC2500 Normal Recorder

2. Click "Save" to save the record file, click "Cancel" will bring out the dialog for users to confirm whether to save the file or not and to stop recording;

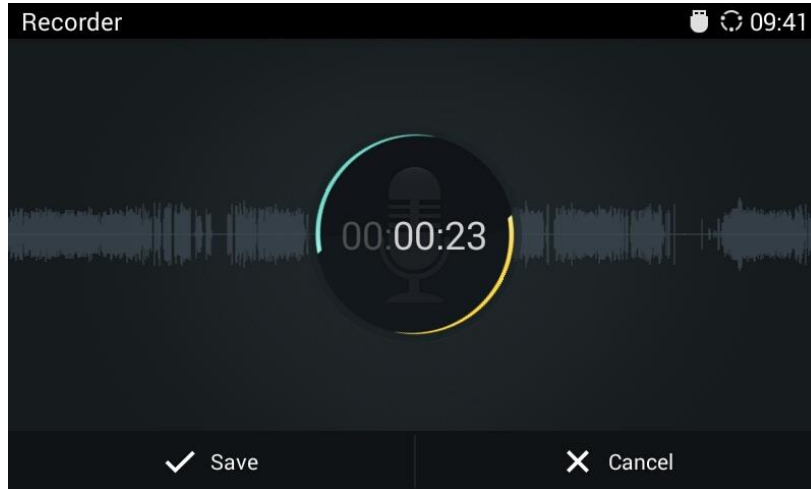



Figure 87 GAC2500 Normal Record-Recording

- Go back to the Recorder page, select one recording file and click  on the right of the progress bar to play the file.

## CALL RECORDER

In the process of an active call, the recording file will be saved on the phone. Users can only listen to it via Recorder. See figure 101 below.

Call ID	Duration	Time
31626	Duration 06:44	11:54
31626	Duration 02:45	10:22
31629	Duration 00:03	10/17 16:55

Figure 88 GAC2500 Call Recordings

## RECORDER SETTINGS

Tap on  on the upper right corner on Recorder screen to sort the recording files, or access the recording screen as shown below:

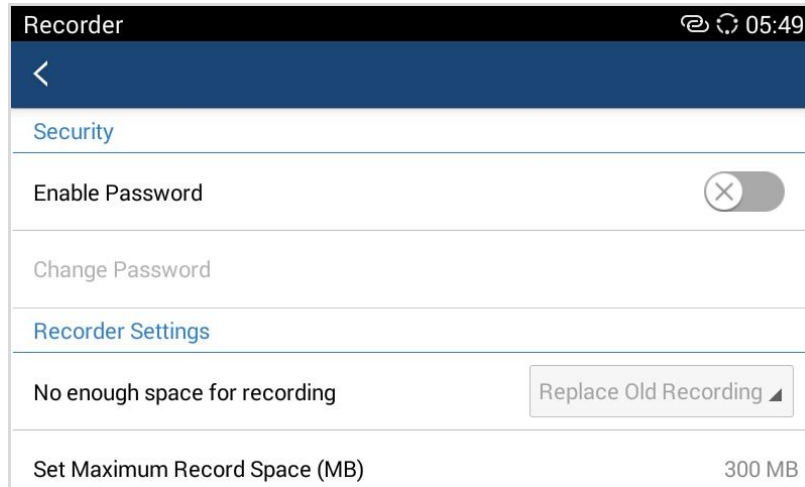

Figure 89 GAC2500 Recorder Settings Screen

**Enable Password.** Enable and set password. Once set the password, input the password to access Recorder.

**Change Password.** To change password, please enable "Enable Password" option first.

**Set Store Location.** When a USB disk is detected, you can set the recorder stored in the USB disk.

**Not Enough Space for Recording.** Set "Replace Old Recording" or "Stop and Save" when there is not enough space for recording.

**Set Maximum Recorder Space (MB).** Set the maximum recording space on the device, you cannot view recording files via File Manager.

**Set Export Location.** It can be an SD card or external export device.

## DIAGNOSIS

Users could make operation like LCD Diagnosis, Keypad Diagnosis, and LED Diagnosis on GAC2500 via built-in Diagnosis app.

## BROWSER

Users could browse webpage, view news and watch video via the built-in GAC2500 Browser. Press on



in the main menu to open Browser.

- Slide up and down with slide gesture to scroll the screen.
- Zoom in/out the page via zoom gesture.
- Press the menu button  on the upper right corner to open the menu bar for more operations.





## GS MARKET

GAC2500 provides direct access to apps via built-in GS market app. Users could download the apps from the market and install to the GAC2500.

### SEARCH APPS

In the GAC2500 Home screen, click on Applications->GS Market . The users could view the apps by category, or input key words and click on SEARCH icon to search.

### DOWNLOAD AND INSTALL APPS

- Users could see if the app has been installed or downloaded by pressing the blue shortcut key.
- Press MENU key  to view the downloaded apps and installed apps.
- Tap on  to cancel download in process.
- Tap on  to try again if the download failed.
- The installing process will be automatically started after downloading the app.
- Go to Installed screen to view the installed apps, or tap on  to uninstall the downloaded apps.

### UPDATE APPS

The GAC2500 will automatically detect if there is new version available for the installed apps to upgrade when the network connection is normal. User can view the relevant information and update apps on the Installed screen.



## GAC2500 WEB UI FEATURES

### ACCESSING GAC2500 WEB GUI

The IP address of the GAC2500 displays on LCD display screen.

To access the GAC2500 Web GUI:

1. Connect the computer to the same network as GAC2500.
2. Open a Web browser on your computer, enter the phone's IP address in the address bar of the browser; for example: http://192.168.124.111;
3. Enter the administrator's login and password to access the Web Configuration Menu. The default username and password are: admin, admin; you can set language to English or Chinese in the drop-down menu of language;

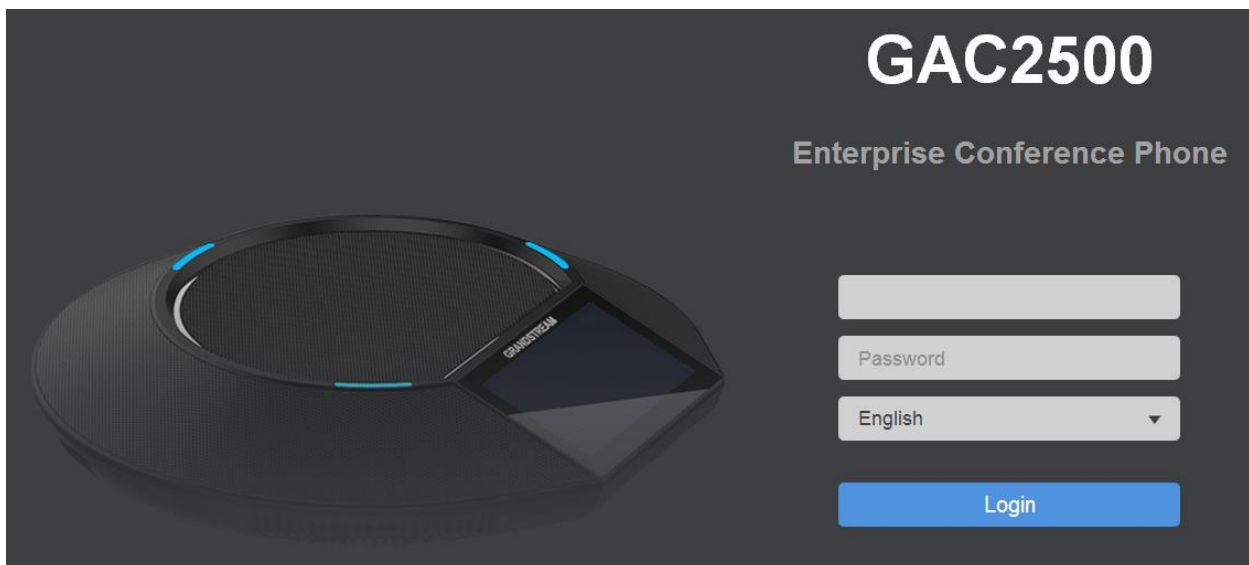
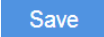



**Figure 90 GAC2500 Web GUI - Login**

4. Click "Login" to access the configurations in web UI.

### SAVING CHANGES

When changing any settings on the web UI, always submit them by pressing the SAVE button

 on the bottom of the page, and then clicking the Apply button on the top of the page to apply the

configuration changes. For those options with  next to it in the Web page, users must reboot the GAC2500 for the changes to take effect.

## DEFINITIONS

This section describes the 6 options in the GAC2500 Web GUI. Please view Advanced, Maintenance and Status specifications in Administration Guide.

- **Call**  
Users could start conference and control conference from Web GUI.
- **Contacts**  
Contacts, Schedule, Call History.
- **Account**  
Configure account info.
- **Advanced**  
General Settings, Call Features, Tone Generator, MPK General Settings, MPK LCD Settings.
- **Maintenance**  
Network Settings, Time & Language, Security Settings, Upgrade, Troubleshooting, Device Manager.
- **Status**  
Account Status, Network Status, System Info.

You can log in as an administrator or a normal user. The following table shows the web pages accessible by normal user and administrator.

**Table 16 GAC2500 Users Access Permissions**

User Type	Username	Default Password	Accessible Web Pages
Normal User	user	123	<ul style="list-style-type: none"> <li>• Call</li> <li>• Contacts</li> <li>• Account: Call Settings</li> <li>• Advanced: MPK General Settings, MPK LCD Settings</li> <li>• Maintenance: Network Settings, Time &amp; Language, Security Settings, Device Manager</li> <li>• Status: Account Status, Network Status, System Info</li> </ul>
Administrator	admin	admin	All pages

## TOOLBAR

The web UI tool bar is on the upper right corner of the web UI page.

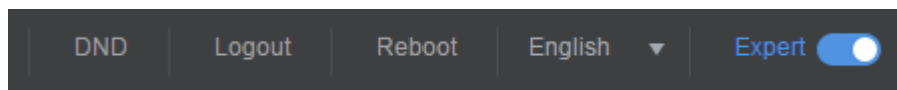

**Figure 91 GAC2500 Web UI Tool Bar**

- **DND**  
Turn on/off DND mode. Once enabled, the DND text will turn into red and all incoming calls will be

- rejected.
- **English**  
Select the display language for the web UI.
- **Reboot**  
Reboot the device.
- **Expert**  
Click to switch to expert mode and click again to cancel. Once enabled, the administrator can view all settings items.
- **Logout**  
Log out from the web UI.

## CALL PAGE

GAC2500 Web UI call page is shown below. Users could make calls and initiate conference from Web UI.

Figure 92 GAC2500 Web UI - Call

## MAKING A CALL

1. Select account in Account Info box;
2. Select call mode, then input phone number (s) in input box, use "," to separate different numbers or tap on other place on screen to confirm your input;

3. Tap on  to dial out.

You can also tap on  behind one call history entry to add the contact to input box.

### SINGLE INCOMING CALL

When the GAC is in idle, the dial screen will pop up when dialing out as shown below:

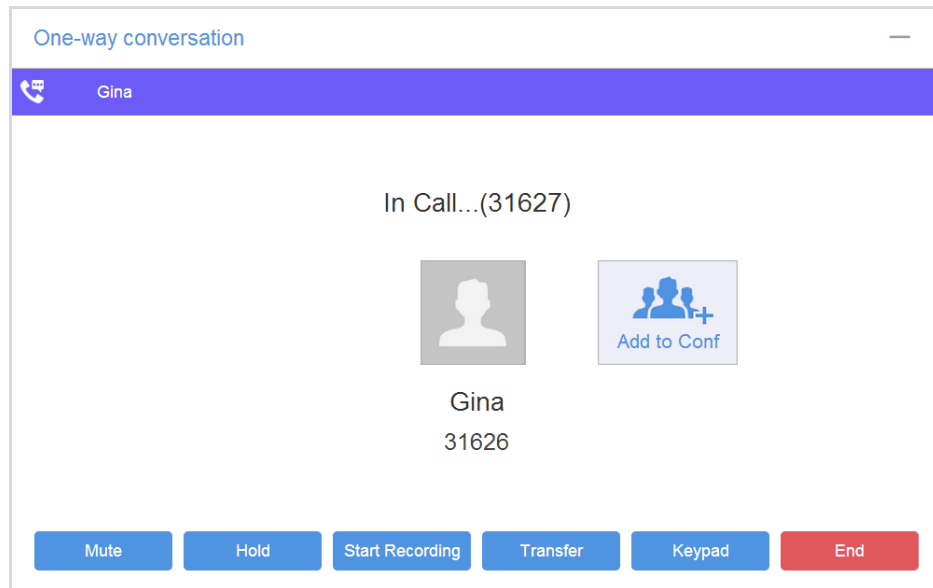



Figure 93 GAC2500 Web UI - Single Incoming Call

If the callee answers the call, you will see dial screen which is the same as the one on GAC2500 LCD.

Tap on  on the upper right corner to minimize dial screen to the lower right corner as shown below:

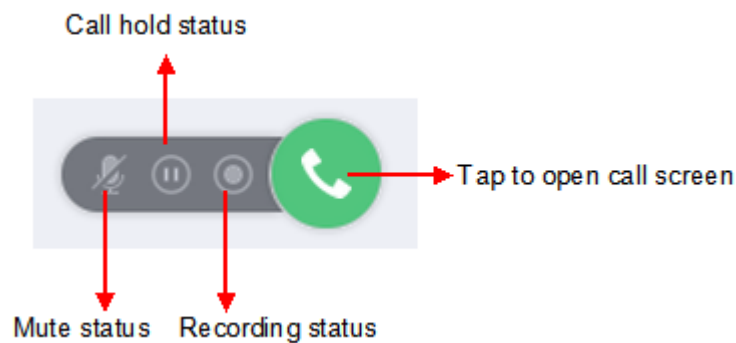
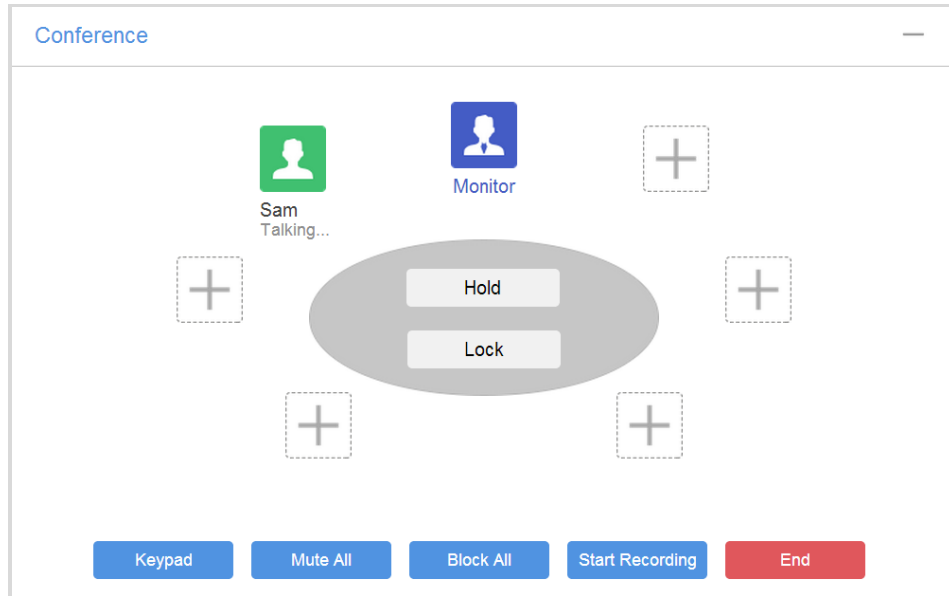

Figure 94 GAC2500 Web UI - Minimize Call Screen

When the line is in mute/hold/recording status, the corresponding icons will be highlighted.

### CONFERENCE CONTROL

When the GAC2500 is on conference, the conference screen is as shown below.



**Figure 95 GAC2500 Web UI - Conference Control**

The conference screen on Web is the same as the one on GAC2500 LCD.

Tap on  on the upper right corner to minimize conference screen to the lower right corner as shown below:

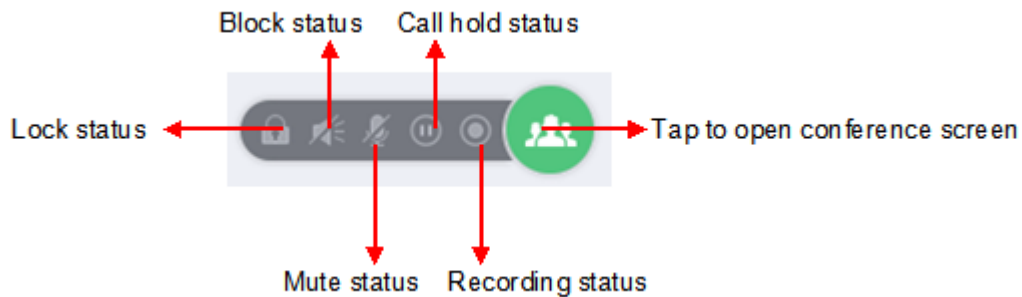

**Figure 96 GAC2500 Web UI - Minimize Conference Screen**

When the line is in lock/mute all/block all/hold/recording status, the corresponding icons will be highlighted.

## CONTACTS PAGE

This page lists Contacts, Schedule, Call History and LADP.

### CONTACTS

The operations will be synchronized and can be viewed from LCD as well.

### CONTACTS

Users could search/add/delete/edit contact on web page. The web UI contacts page is as shown below.

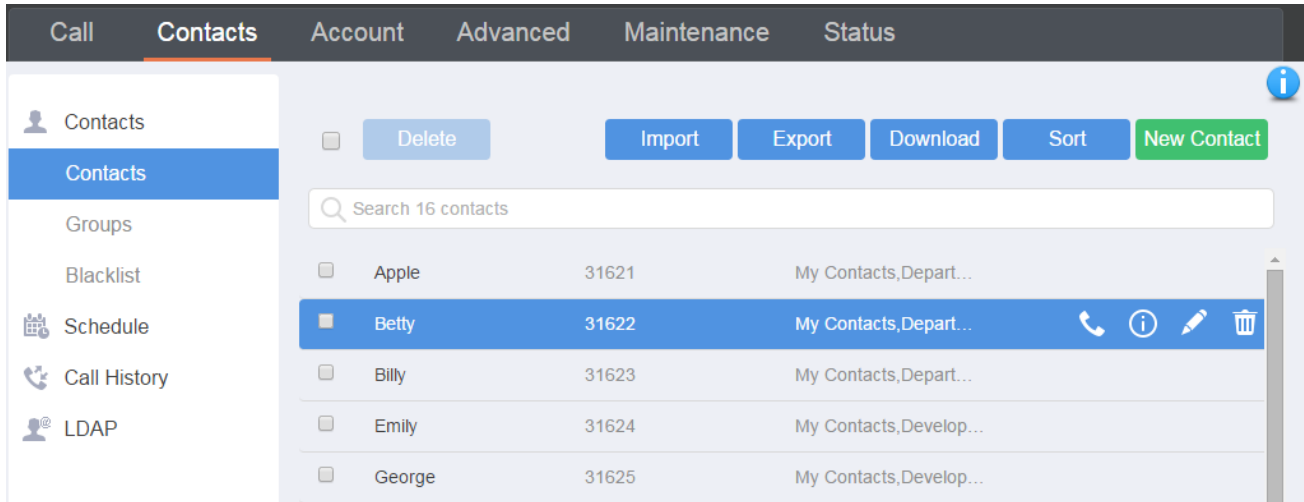

Figure 97 GAC2500 Web UI - Contacts

- Tap on "Import" option to access Import screen. Refer to chapter **BATCH IMPORT CONTACTS** to fill in info and import the contacts on PC to device.
- Tap on "Export" option to access Export screen. Refer to chapter **EXPORT CONTACTS** to fill in info and export the contacts on device to PC.
- Tap on "Download" option to access Download screen. Refer to chapter **DOWNLOAD CONTACTS** to fill in info and download the contacts on server to PC.
- Tap on "Sort" option to access Sort Phonebook screen. Sort the contacts by first name or last name.
- Tap on "New Contact" option to access Add Contact screen. Fill in contact information and save.

Put the cursor on contact to display more operation buttons.



: Tap to dial this contact.



: Tap to view the contact details.



: Tap to access Edit screen, you can edit contact and save the changes.



: Tap to delete this contact.

## GROUPS

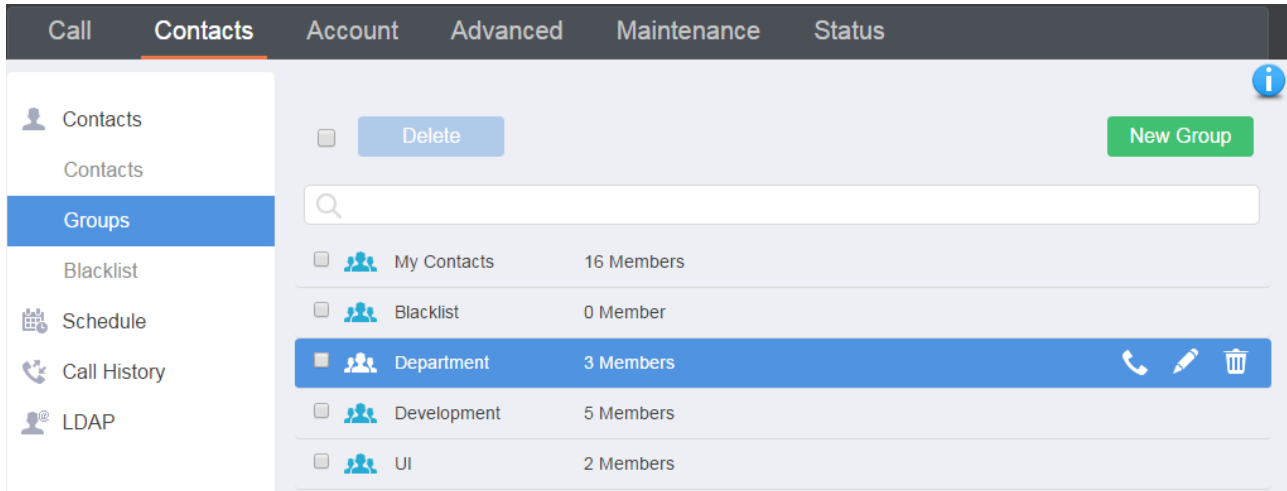

Figure 98 GAC2500 Web UI – Groups

- Tap on "New Contact" option to access New Group screen. Input group name and check group member (s) then save.
- Click on the group name to view all members in this group.

Put the cursor on group to display more operation buttons.



: Tap to call this group. Please note that GAC2500 supports up to 6 lines (7-way) conference. If there are more than 6 conference members, check 6 members you want to add to conference first.



: Tap to access Edit screen, you can edit group and save the changes.



: Tap to delete this group, the contacts in this group will not be deleted the same time.

## BLACKLIST

Blacklist function on Web UI is the same as on local. Please refer to chapter **Blacklist** for more details.

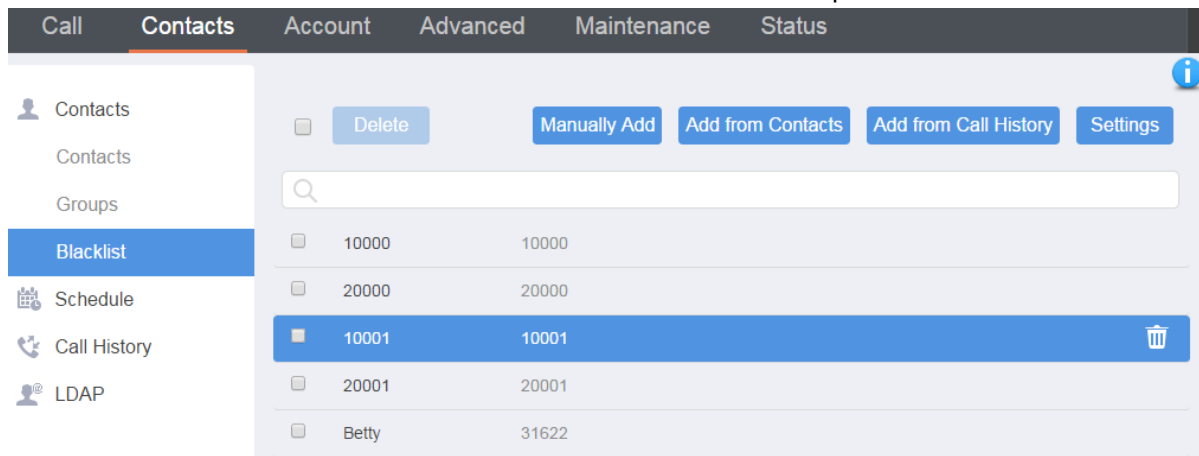

Figure 99 GAC2500 Web Page - Blacklist

## SCHEDULE

You can refer to chapter **Schedule** for more details.

### UPCOMING CONFERENCE

Conference can be scheduled, edited and deleted from web UI.

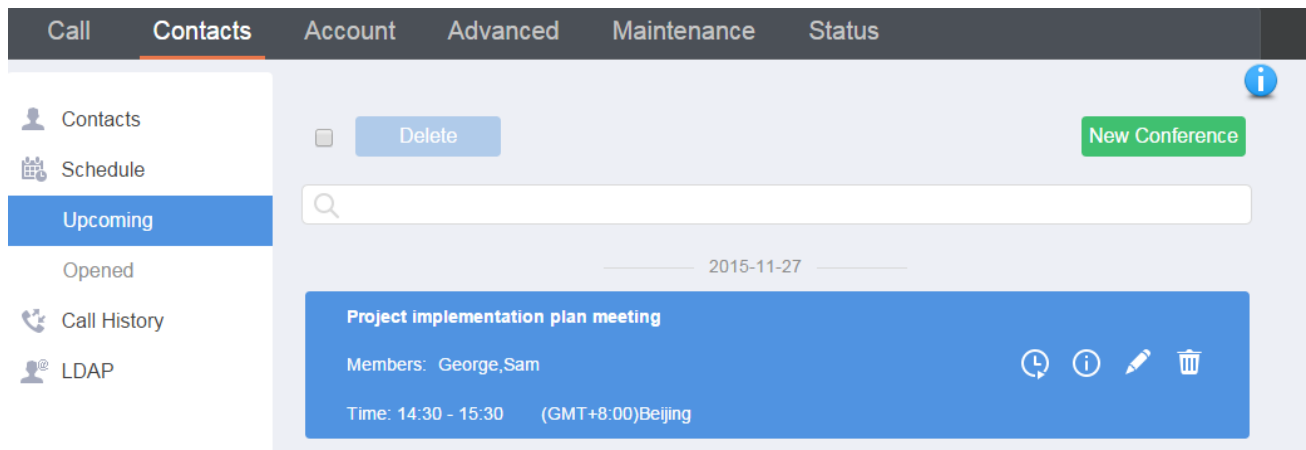

Figure 100 GAC2500 Web Page - Upcoming Conference

- Tap on "New Conference" option to access New Conference screen. Input conference name and check conference member (s) then save.

Put the cursor on conference to display more operation buttons.



: Tap to call this conference.



: Tap to access Details screen. You can also edit and save conference on this screen.



: Tap to access Edit Schedule screen, you can edit conference and save the changes.



: Tap to delete this conference.

### HISTORY CONFERENCE

History conference screen is as shown below, you can dial/reschedule/delete history conference from web UI.



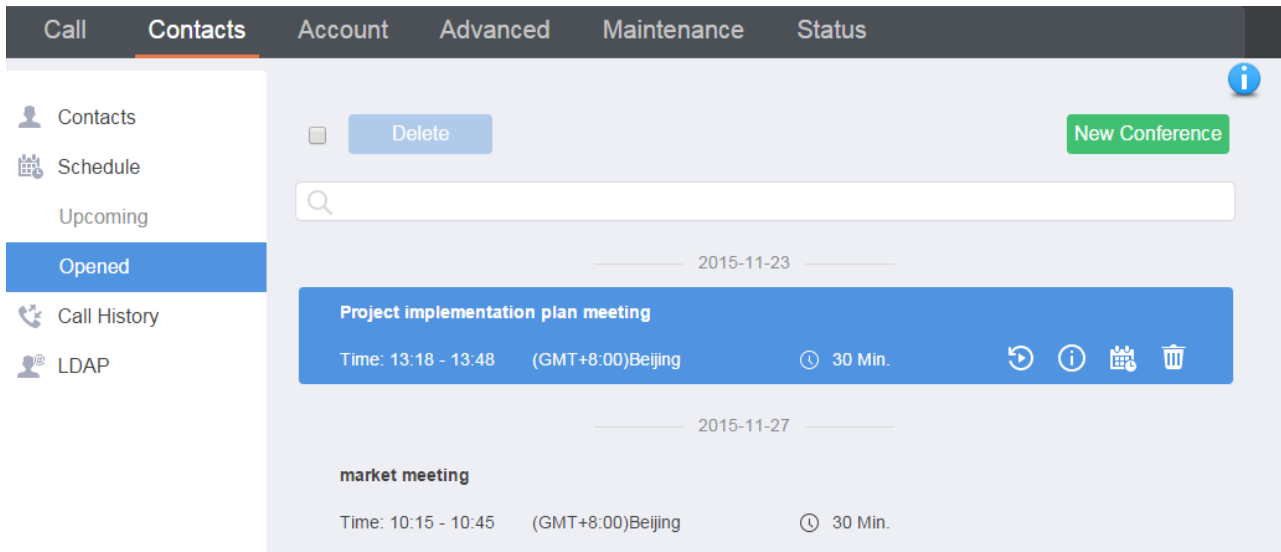

Figure 101 GAC2500 Web Page - History Conference

Put the cursor on conference to display more operation buttons.



: Tap to call this conference.



: Tap to access Details screen. You can also edit and save conference on this screen.



: Tap to access Edit Schedule screen. You can reschedule the history conference on this screen.



: Tap to delete this conference.

## CALL HISTORY

From web UI, users could also access Call history, which is synchronized with the call history from LCD.

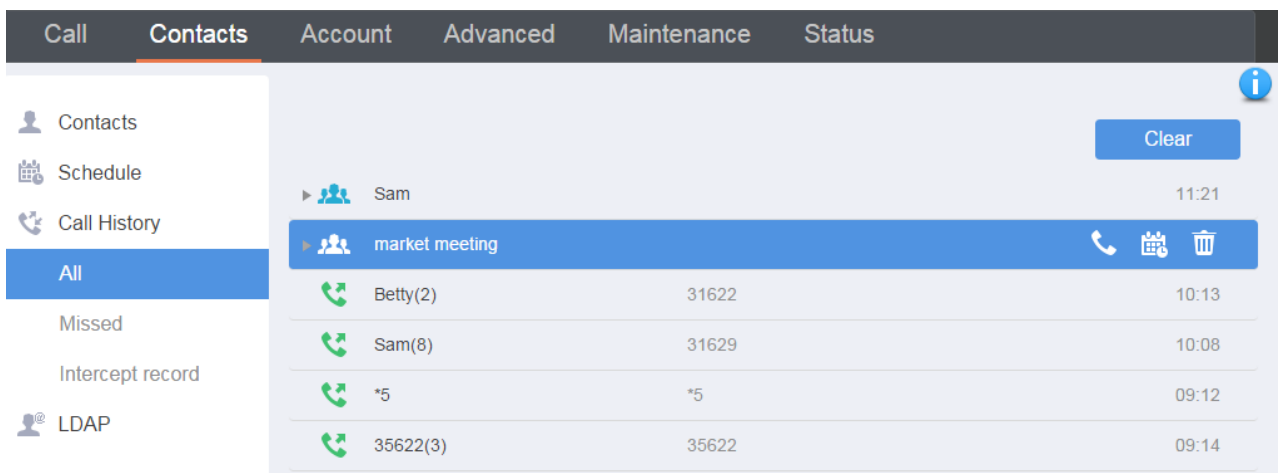

Figure 102 GAC2500 Web UI - Call History

- Tap on "Clear" option to clear all call history.

Put the cursor on call history to display more operation buttons.



: Tap to call this contact.



: Tap to access Edit Schedule screen. You can reschedule the history conference on this screen.



: Tap to delete this conference.

## LDAP

From web UI, users can configure LDAP contacts. Please refer to chapter of **LDAP** under Application to fill in info and import LDAP contacts.

## EXPERIENCING GAC2500

Please visit our website: <http://www.grandstream.com> to receive the most up-to-date updates on firmware releases, additional features, FAQs, documentation and news on new products.

We encourage you to browse our product related documentation, FAQs and User and Developer Forum for answers to your general questions. If you have purchased our products through a Grandstream Certified Partner or Reseller, please contact them directly for immediate support.

Our technical support staff is trained and ready to answer all of your questions. Contact a technical support member or submit a trouble ticket online to receive in-depth support.

Thank you again for purchasing Grandstream Enterprise Conference Phone, it will be sure to bring convenience and color to both your business and personal life.

---

\* **Android is a trademark of Google Inc.**

\* **Skype and Skype for Business are Registered Trademarks of Microsoft Corporation.**

---