

This guide provides guidance on the safe and effective installation and operation wall mounted Li-ion batteries. It also provides information on how to safely connect multiple batteries in parallel (Max. 6), as well as how to charge and discharge the batteries.

CAUTION

- Due to the regulations governing the transportation of Lithium Ion cells and batteries internationally. The battery is only 50% SOC during transport. Please charge battery fully in the first use.
- Before connecting any electrical cable, turn OFF all the switches and breakers and turn OFF the batteries by press the ON/OFF button.
- Avoid any fall or collision during the installation process.
- Do not remove the battery components. The maintenance of the battery should be carried out by a professional engineer.
- Do not expose the Li-ion battery to heat in excess of 55°C during operation, 60 °C in storage.

System Introduction

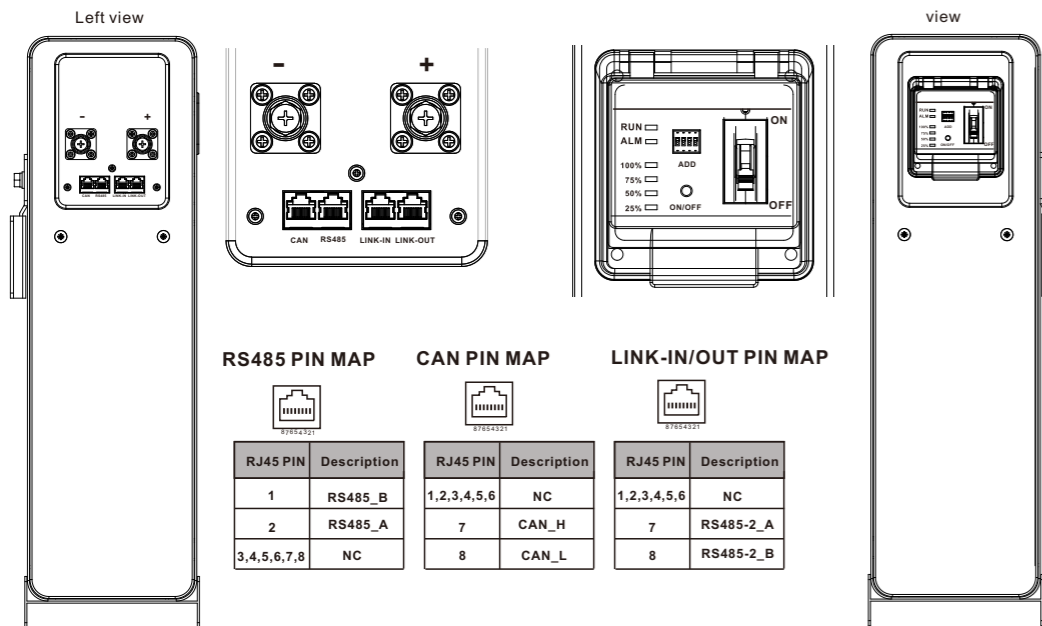

ON/OFF Button



OFF mode

During in transport, BMS ON/OFF button is at OFF status. it will turn off the BMS power supply.



ON mode

By press ON/OFF button to active BMS to enter into working mode, if the MCB is also ON, the battery voltage will can be measured by terminal.

Even if the button is at ON mode, The BMS will enter into dormancy mode after 24 hours when there are no charge, no discharge and no communication. it can be activated again by charge or communication or repress ON/OFF button.

1 Unpacking Inspection

1. Unpack the battery and visually inspect the appearance. If any shipping damage is found, notify the carrier immediately.
2. Press ON/OFF button to active the battery, the SOC and RUN indicator will be light. turn on MCB to measure the output voltage by multimeter, For parallel application, the voltage difference should less than 500mV.
3. Press ON/OFF button to shutdown the battery, the indicator light will turn off.
4. Check the accessories which should include:

4.1. Accessories for RES1005K

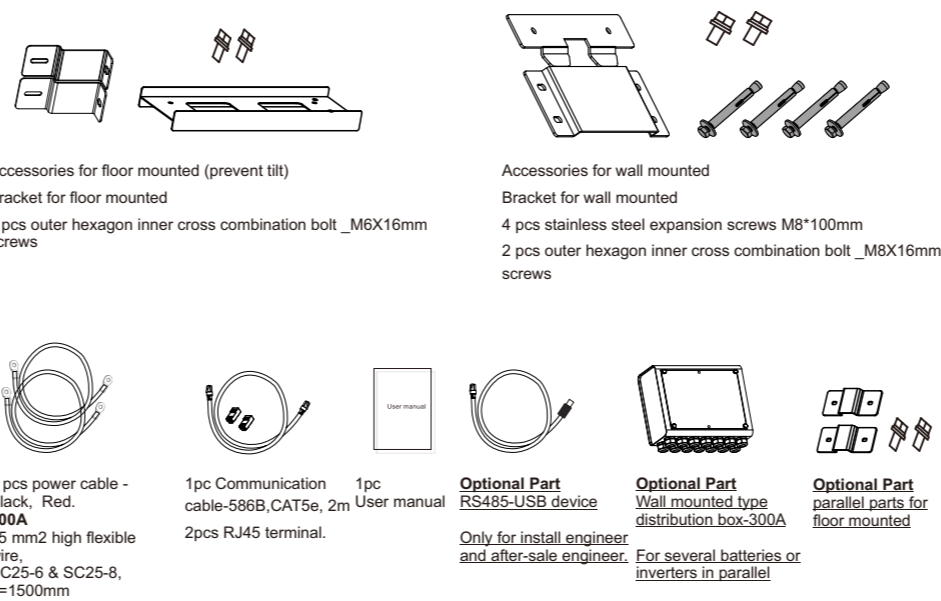

4.1. Accessories for RES20010K

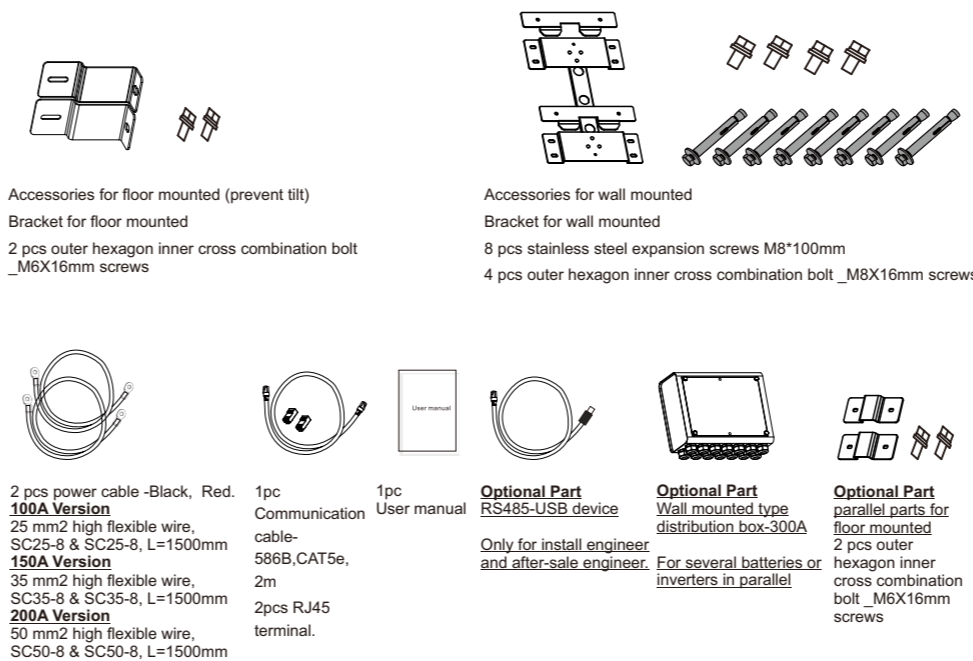

2 Mechanical Installation

2.1. Wall mounted for RES1005K

Take out wall mounted accessories which include bracket and screws,

Fix the bracket on the battery and remove the floor mounted part on the bottom of battery.

Drill 4 pcs $\Phi 10 \times 110$ mm holes on the wall, fix wall mounted part on the wall and fasten the screw head of the expansion bolts

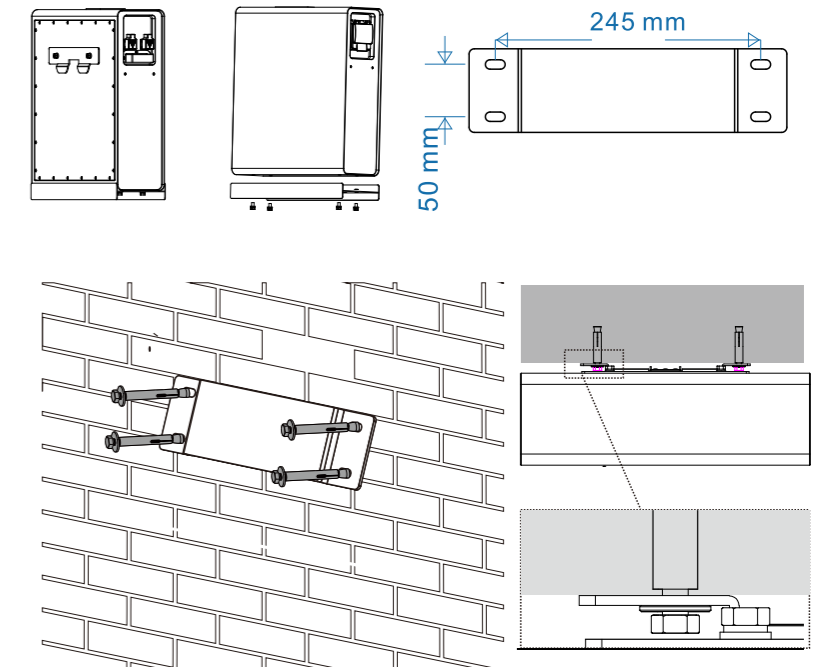

Note:

- Remember that the battery is heavy ! Please be careful when doing operation.
- Use a proper hammer to fit the expansion bolt into the holes. The screw head protruding too long may interfere with the battery cabinet.

2.2. Floor mounted for RES1005K

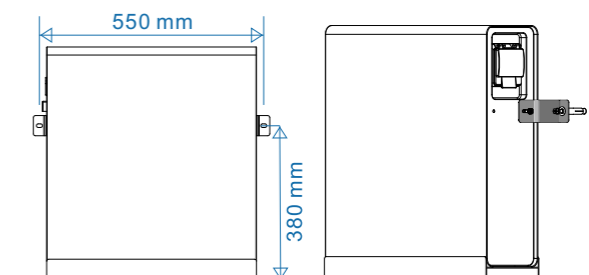

2.3. Wall mounted for RES20010K

Take out wall mounted accessories which include bracket and screws,

Fix the bracket on the battery.

Drill 8 pcs $\Phi 10 * 110\text{mm}$ holes on the wall, fix wall mounted part on the wall and fasten the screw head of the expansion bolts.

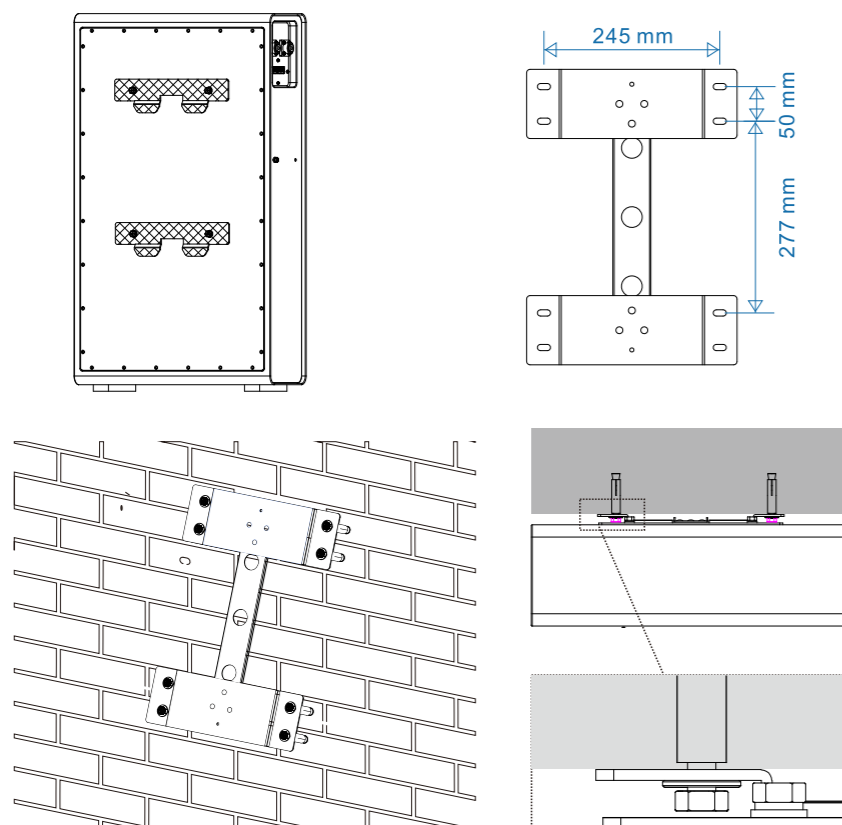

Note:

- Remember that the battery is heavy (96Kg)! Please be careful when doing operation.
- Use a proper hammer to fit the expansion bolt into the holes. The screw head protruding too long may interfere with the battery cabinet.

2.4. Floor mounted for RES20010K

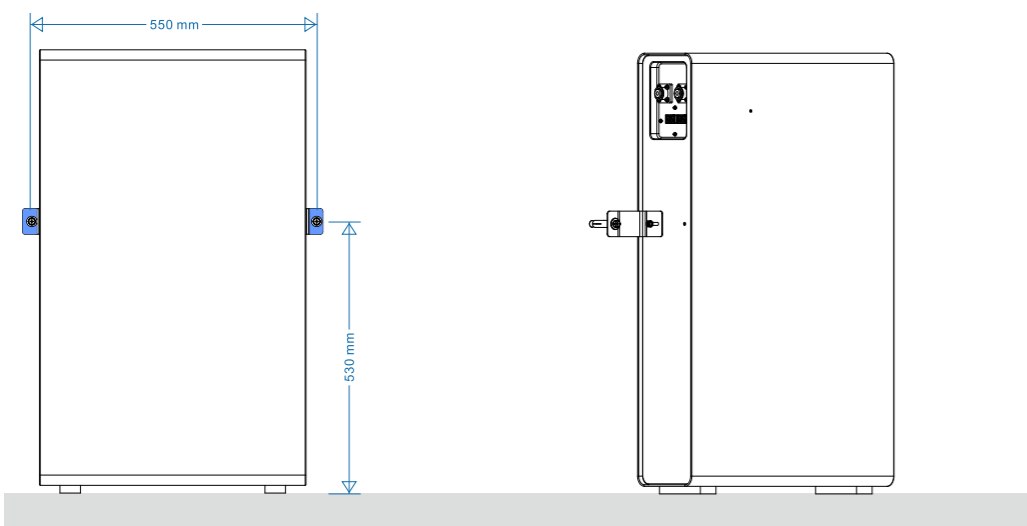

3 Parallel Connection

For floor mounted parallel connection, it supports to install as below:

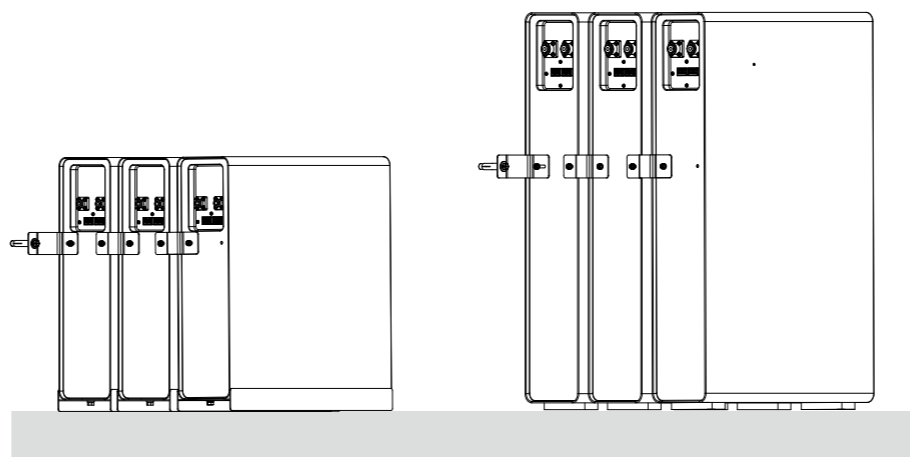

4 Cable Connection

4.1 Single inverter with single battery

- Step 1. Make sure the battery breaker is in off condition. Connect the power cable to inverter. Make sure the screws are tight.
- Step 2. Connect the communication cable.
- Step 3. Set the battery module ID by ADD. **The master battery which do communication with inverter ADD must be 1.**
- Step 4. Make sure the inverter had be installed correctly.
- Step 5. Press ON/OFF button to active the battery BMS and connect battery to PC by BMS PC software, select inverter protocol on BMS (detail operation refer to user manual)
- Step 6. Turn on battery breaker and the inverter will be activated, set the inverter (battery type and protocol).
- Step 7. If the communication between BMS and inverter is nominal, the SOC, temperature information in PC and inverter display will be totally same.
- Step 8. **Charge the batteries fully in first use.**

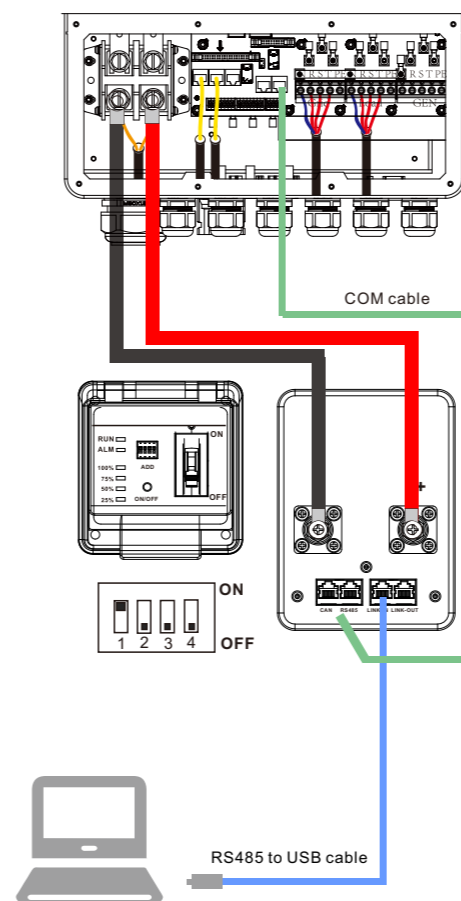

Note:

- For 1pcs 5KWH and RES20010K-100A, it max support 5KVA inverter or the real load power consumption is less than 5KW.
- For 1pcs RES20010K-150A battery, it max support 8KVA inverter or the real load power consumption is less than 7KW.
- For 1pcs RES20010K-200A battery, it max support 10KVA inverter or the real load power consumption is less than 8KW.

4.2 Single inverter with 2 batteries

The below power cable connection can't increase current. can support prolong the backup time,

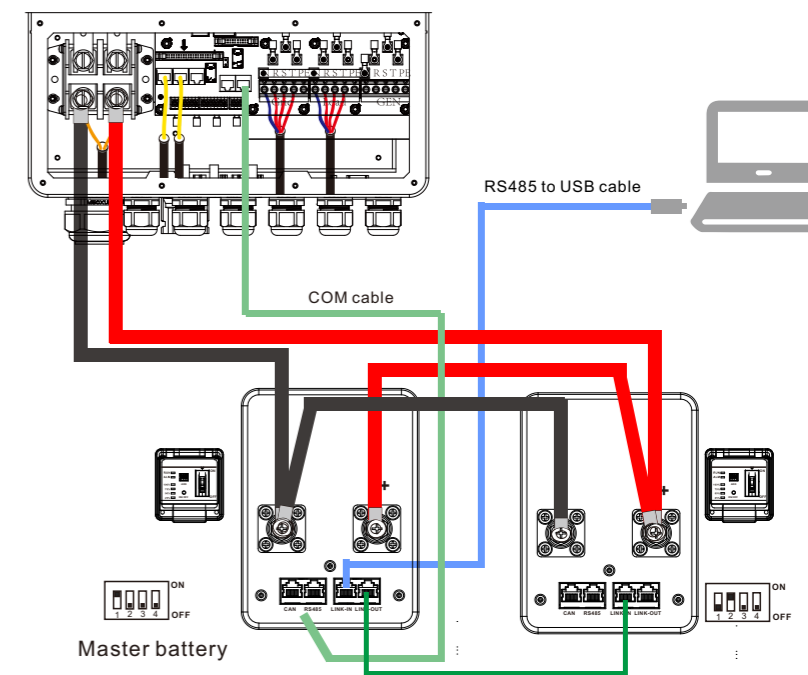

4.3 Single inverter with 2 batteries

The below power cable connection can increase current to support big capacity inverter.

The length of power cable should be the same.

