



**SILENT  
KNIGHT**

by Honeywell

## ECS-INT50W Internal Amplifier Installation Instructions

The ECS-INT50W Internal Amplifier can fit inside the IFP-2000ECS, IFP-1000ECS, or IFP-100ECS cabinet. It is used to amplify the audio message for distribution throughout the facility for the Emergency Communication System.

### Compatibility

The ECS-INT50W is compatible with the Silent Knight IFP-2000ECS, IFP-1000ECS and IFP-100ECS FACP's. For programming settings, refer to Installation manuals for IFP-2000ECS (PN 151430-L8), IFP-1000ECS (PN 151460), and IFP-100ECS (PN 151458).

### Board Layout & Mounting

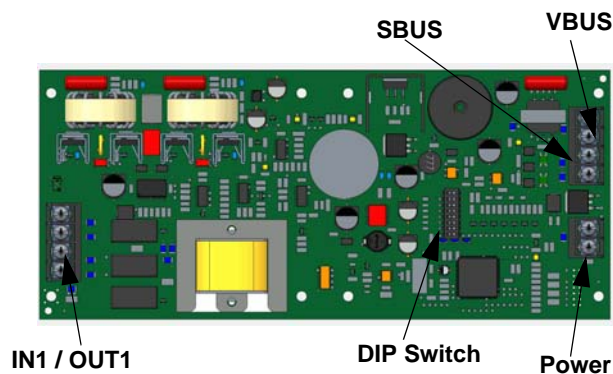

Figure 1: Front View of ECS-INT50W

### Mounting the ECS-INT50W

1. Open the cabinet door.
2. Remove AC power and disconnect the backup batteries from the main control panel.
3. Align the board with the mounting holes. Mount the ECS-INT50W inside the FACP cabinet with

the screws provided. See Figure 2.

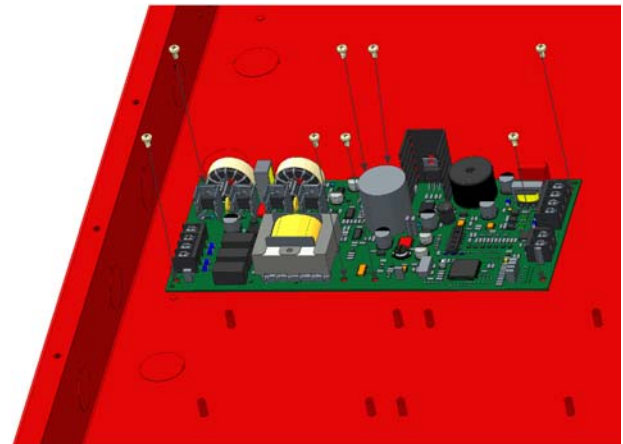

Figure 2: ECS-INT50W in FACP Cabinet

4. Secure the board to the enclosure.

### Specifications

Standby Current: 52 mA

ECS-INT50W only Alarm Current: @ 25V 275 mA; @ 70V 310 mA

Full Alarm load current: @ 25V 2840 mA; @ 70V 2900 mA

## Wiring to a FACP

See Figure 3 to properly wire the ECS-INT50W to the FACP.

The Internal Amplifier must be powered by a NAC programmed as Constant Auxiliary Power. Refer to the FACP installation manual.

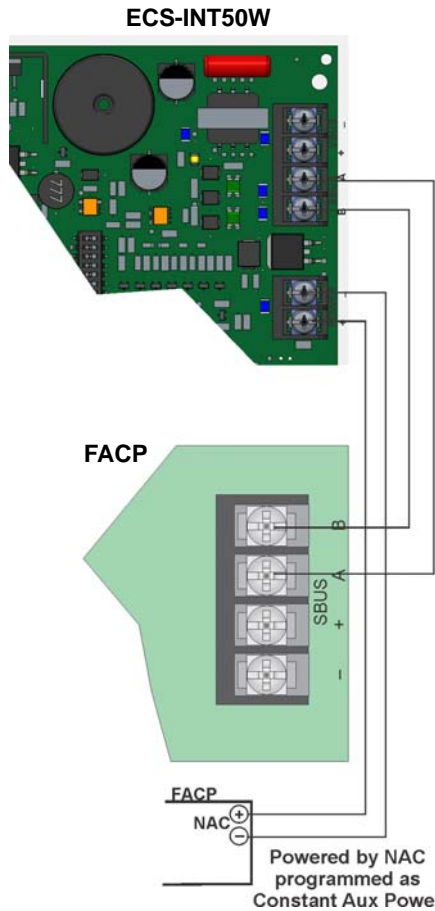

Figure 3: Wiring the ECS-INT50W to the FACP

## VBUS Wiring

The VBUS is an analog voice bus that carries the recorded voice messages from the ECS-VCM to the ECS-INT50Ws, or the voice messages generated from a system microphone to the ECS-INT50W.

The maximum resistance on the VBUS is 20Ω.

Connect the VBUS from the ECS-VCM to the VBUS on the ECS-INT50Ws as shown in Figure 4.

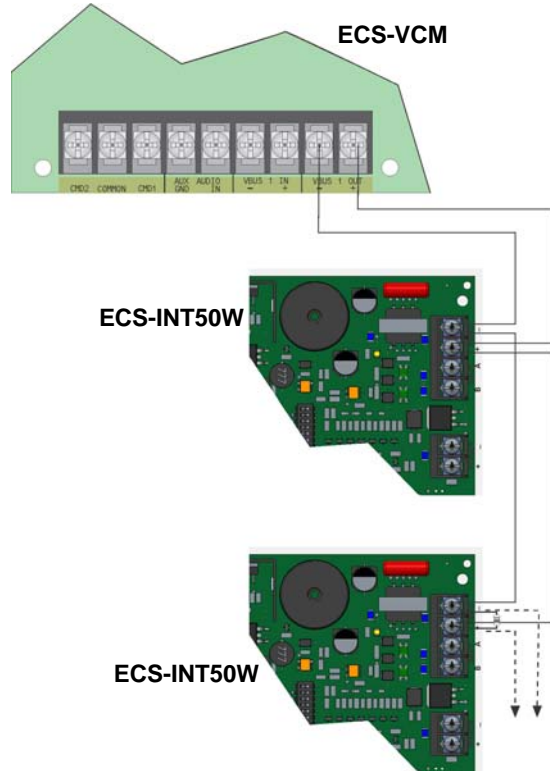
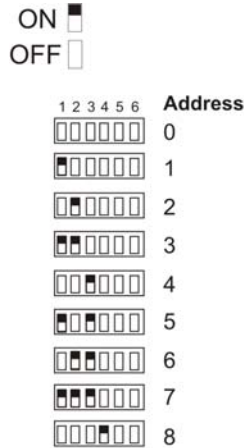

Figure 4: VBUS Wiring

## Setting the Device Address

Use the on-board DIP switches to select an ID number for the ECS-INT50W. Refer to Figure 5 to see how to set the DIP switches for the desired ID number.



\*Note: Address 0 cannot be used.

**Figure 5: DIP Switch**

Once the ID number is set, you must add the ECS-INT50W to the system through programming.

**Note:** ECS-INT50W is powered by a NAC. It will not be found using JumpStart AutoProgramming.

## Speaker Wiring

Each ECS-INT50W supplies one circuit for speaker connection. The speaker circuit can be supervised and wired Class B (Style Y) or Class A (Style Z). The speaker circuit is capable of 50 watts of power at 25 Vrms or 70.7 Vrms.

## Wiring Lengths

**Table 1: Wire Lengths**

Number Of Speakers		Total Load		Wire Distance in Feet			
@ ½ W	@1 W	Vrms	Watts	18 AWG	16 AWG	14 AWG	12 AWG
10	5	25Vrms	5W	3900	6200	9860	15680
		70Vrms		25000	39700	63200	100520
20	10	25Vrms	10W	2125	3380	5375	8540
		70Vrms		15200	24150	38400	61100
30	15	25Vrms	15W	1460	2320	3690	5870
		70Vrms		11000	17500	27800	44200
40	20	25Vrms	20W	1100	1750	2780	4420
		70Vrms		8500	13510	21500	34175
52	26	25Vrms	26W	760	1200	1920	3050
		70Vrms		6100	9700	15400	24520
80	40	25Vrms	40W	550	875	1390	2200
		70Vrms		4100	6500	10360	16480
100	50	25Vrms	50W	450	715	1130	1800
		70Vrms		3500	5560	8850	14070

**Note:** The above table assumes a uniform distribution of the speakers, and that a max of 20% voltage drop on the last speaker is allowed.

Figure 6 illustrates how to wire speakers to the control panel using Class B (Style Y) supervision.

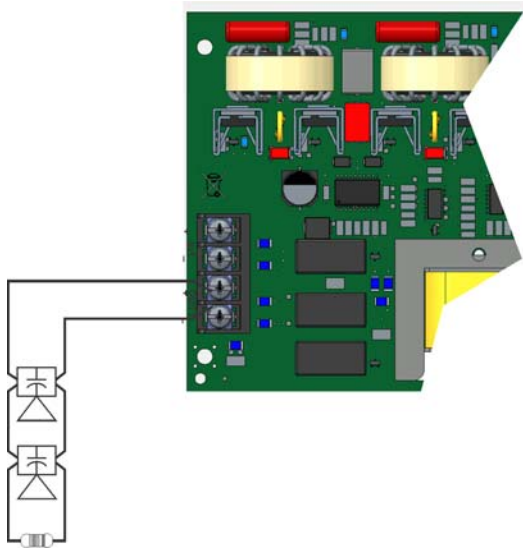

**Figure 6: Class B (Style Y) Speaker Configuration**

Figure 7 illustrates how to wire speakers to the control panel using Class A (Style Z) wiring.

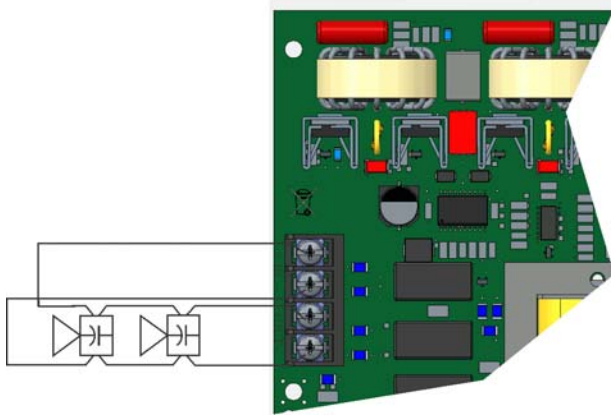

**Figure 7: Class A (Style Z) Speaker Configuration**

## Compatible 520Hz Signaling Speakers

**Table 2: 520Hz Speakers**

Model Number	Description
SPSW	Wall High-Fidelity Speaker Strobe, White
SPSCR	Ceiling High-Fidelity Speaker Strobe, Red
SPSCW	Ceiling High-Fidelity Speaker Strobe, White
SPSCWH	Ceiling High-Fidelity Speaker Strobe, High Candela, White
SPSCRH	Ceiling High-Fidelity Speaker Strobe, High Candela, Red
SPSCW-CLR-ALERT	Ceiling High-Fidelity Speaker Strobe, Clear Lens, ALERT, White
SPSCW-P	Ceiling High-Fidelity Speaker Strobe, Plain, White
SPSCWH-P	Ceiling High-Fidelity Speaker Strobe, High Candela, Plain, White
SPSR-P	Wall High-Fidelity Speaker Strobe, Plain, Red
SPSRH-P	Wall High-Fidelity Speaker Strobe, High Candela, Plain, Red
SPSCWH-P	Ceiling High-Fidelity Speaker Strobe, High Candela, Plain, White
SPSW-ALERT	Wall High-Fidelity Speaker Strobe, Amber Lens, ALERT, White
SPSW-CLR-ALERT	Wall High-Fidelity Speaker Strobe, Clear Lens, ALERT, White
SPSW-P	Wall High-Fidelity Speaker Strobe, Plain, Red
SPSWH	Wall High-Fidelity Speaker Strobe, High Candela, White
SPSWH-P	Wall High-Fidelity Speaker Strobe, High Candela, Plain, Red

**Table 2: 520Hz Speakers**

Model Number	Description
SPR	Wall High-Fidelity Speaker, Red
SPW	Wall High-Fidelity Speaker, White
SPCR	Ceiling High-Fidelity Speaker, Red
SPCW	Ceiling High-Fidelity Speaker, White
SPSR	Wall High-Fidelity Speaker Strobe, Red
SPSRH	Wall High-Fidelity Speaker Strobe, High Candela, Red



12 Clintonville Road  
 Northford, CT 06472-1610 USA  
 203-484-7161  
 Fax: 203-484-7118  
 www.silentknight.com

© 2015 Honeywell International Inc.