

DS-D40W-2F

600 × 337.5 Indoor LED

- Highly integrated and lightweight design.
- Easy to disassemble lamp board, power supply, and receiving card on the front side with high-precision aluminum die casting cabinet design.
- Compatible cabinet structure with COB(DS-D40XXBW-2FC), HOB(DS-D40XXAW-2FQ), SMD(DS-D40XXCW-2F).
- The packaging adopts recyclable materials, and the whole process of production achieves green and low-carbon standards.
- Please note: Module and cabinet structure should be separately ordered.

▪ Specification

Product Model	
Product Model	DS-D40W-2F
Product Type	
Product Type	LED Display Structure
Cabinet	
Dimensions (W × H × D)	600 (W) × 337.5 (H) × 29.5 (D) mm (23.622" × 13.287" × 1.161")
Area	0.2025 m ²
Weight	3.4 kg
Cabinet Material	Aluminium die casting
Maintenance Method	Front maintenance for all components
Power	
Input Voltage	100~240 VAC ± 10%
Working Environment	
Working Temperature	-10 ℃ to 40 ℃ (14 ℉ to 104 ℉)
Working Humidity	10% to 60% RH (without condensation)
Storage Temperature	-20 ℃ to 60 ℃ (-4 ℉ to 140 ℉)
Storage Humidity	10% to 85% RH (without condensation)
General	
Package Dimensions (W × H × D)	1-in-1: 687 X 405 X 74 mm; 5-in-1: 708 X 393 X 433 mm
Packing List	Regulatory Compliance and Safety Information × 1 Connecting screws, light beads, driver IC, iron sheets
G.W.	4.5 kg (1 package in 1 box)
Net Weight	3.4 kg
Bracket	
Modular Bracket	DS-DL116033W 1*1; DS-DL126033W 1*2; DS-DL226033W 2*2

▪ Available Model

DS-D40W-2F 600*337.5mm Cabinet Structure

▪ Dimension

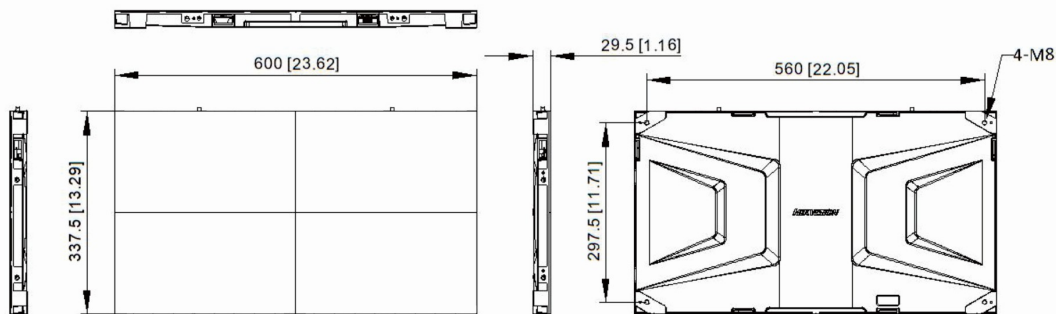

Unit: mm [inch]

See Far, Go Further



www.hikvision.com
support@hikvision.com

