

**DP-D40XXCB22-1X1-Q0.2-NW-Q0.2-ZF**  
**600\*337.5mm 1\*1 Ultra-thin Wall-Mounting Modular Bracket**



- Cost-effective
- Block-based design
- Quick and easy installation
- Thinner and lighter
- Extension supported

## ▪ Specification

General	
Package Dimension (W × H × D)	651 (W) mm × 375 (H) mm × 48 (D) mm (25.63 " × 14.76 " × 1.89 ")
Gross Weight	2.1 ± 0.5 Kg (4.64 ± 1.1 lb)
Net Weight	1.7 ± 0.5 Kg (3.71 ± 1.1 lb)
Dimension (W × H × D)	600 mm × 337.5 mm × 25.5 mm (23.62" × 13.29" × 1")
Default Parameters	
Color	Black
Material	Cold-rolled steel plate (SPCC)
Surface Treatment	Powder coating

## ▪ Available Model

DP-D40XXCB22-1X1-Q0.2-NW-Q0.2-ZF

## ▪ Dimension

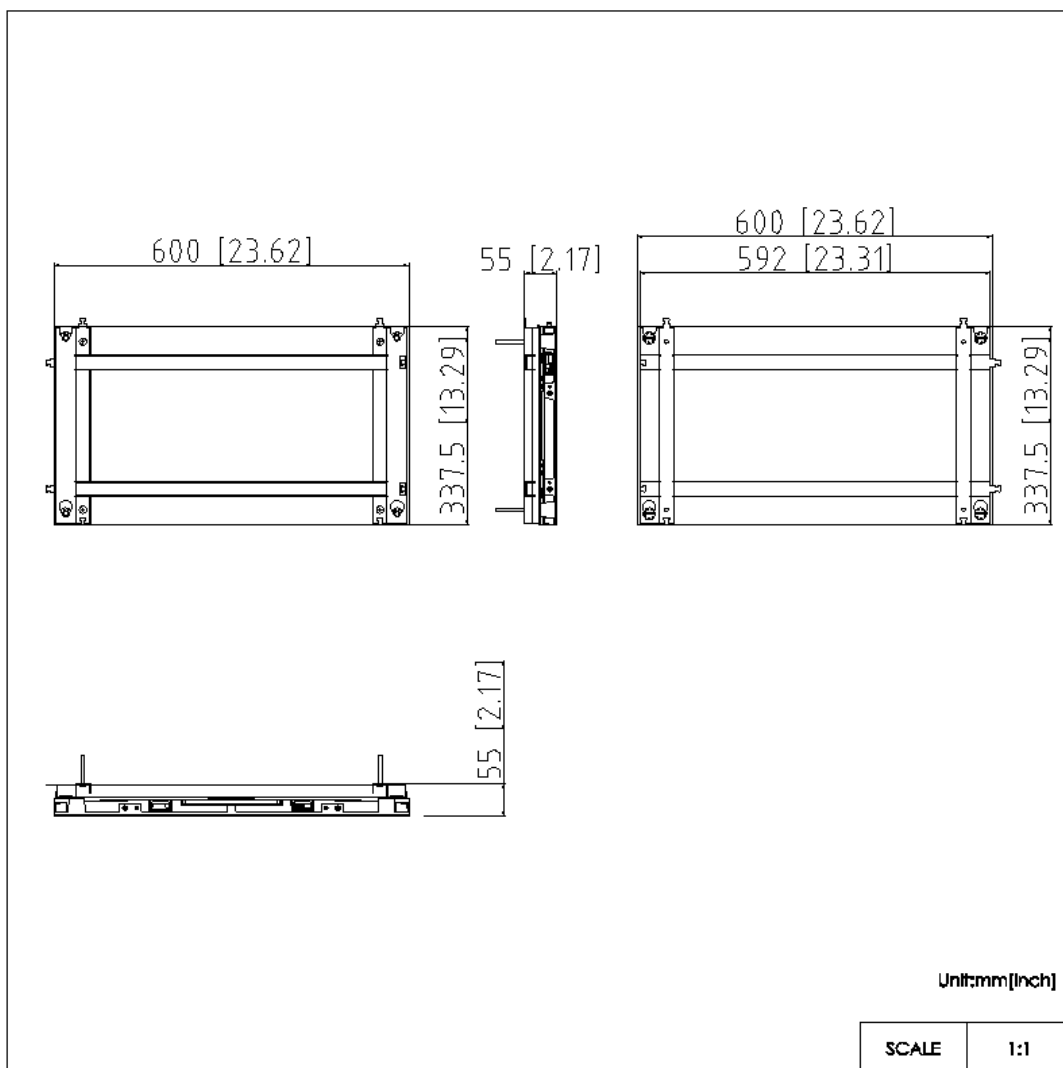

## ▪ Accessory



DS-D40W-2F/DR



DS-D40W-2F

# See Far, Go Further



[www.hikvision.com](http://www.hikvision.com)  
[support@hikvision.com](mailto:support@hikvision.com)

