

ADAPTADOR DE MONTAJE | DH-PFA111

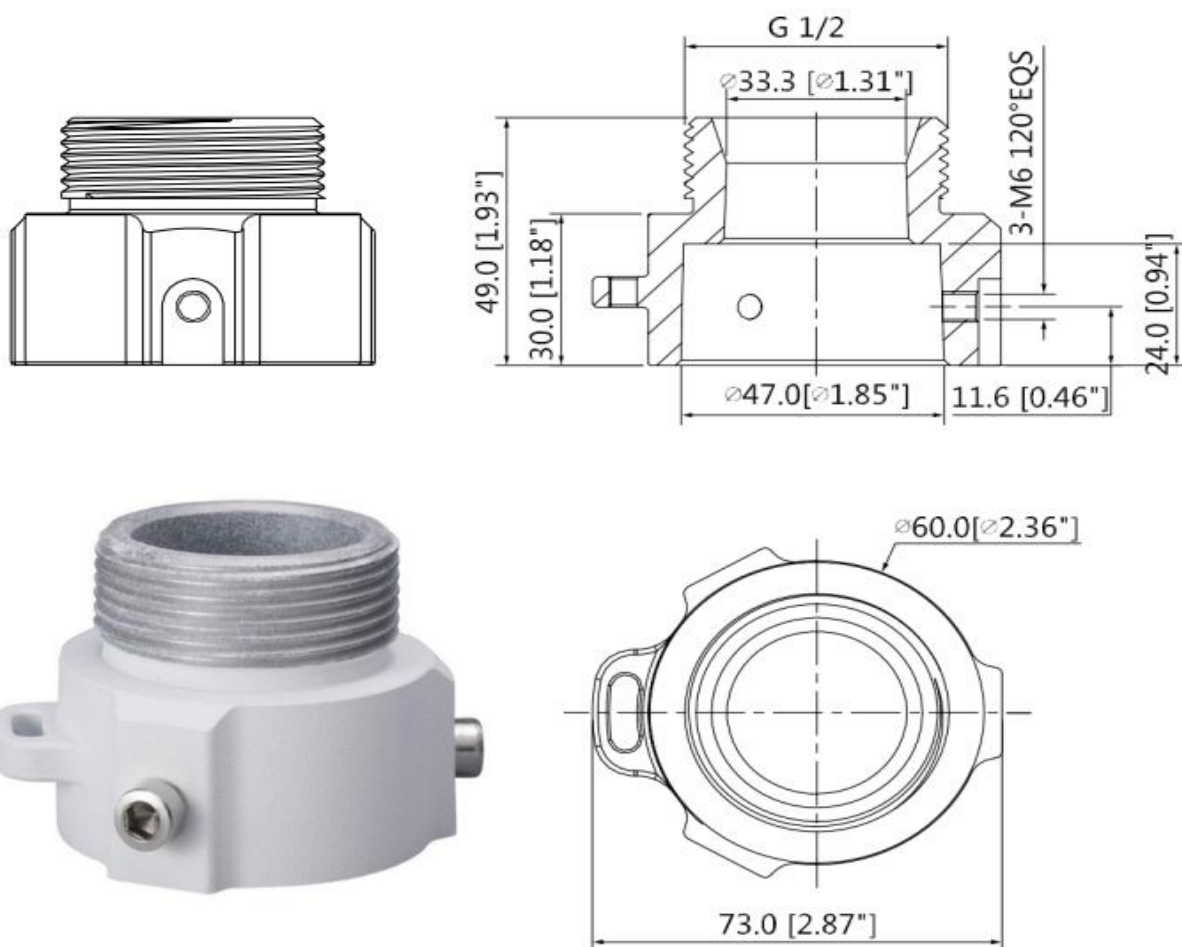

MODELO	DH-PFA111
GENERAL	
MATERIAL	ALUMINIO
DIMENSIÓN (AxAxL)	Φ60mmx49mm (Φ2.36 "x1.93")
PESO	0.25KG (0.55LBS)
MURO DE CARGA	7KG (15.43LBS)
COLOR	BLANCO
TEMPERATURA DE FUNCIONAMIENTO	-40°C~+60°C (-40°F~+140°F)
HUMEDAD	<90%HR
HILO DE TUBERÍA	G1 1/2 pulg.