

Installation&tuning

BEFORE OPERATION

1. Connect one or two pads to P1 and/or P1 of the controller
2. Power on:
 - (1) Red Power LED on controller lights up and buzzer inside controller beeps once, meaning the controller works well;
 - (2) Red Power LED on pad blinks, meaning the deactivator set works well.

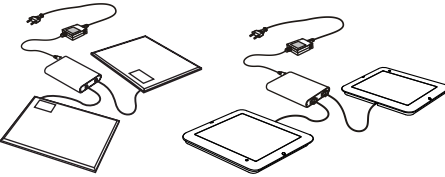

OPERATION

When an active RF label approaches to the deactivator pad and is around 20cm to the surface,if

- (1) Status LED on the pad lights in blue color;
 - (2) Detection LED on the controller blinks in blue color;
 - (3) Buzzer inside controller beeps continuously, it means that the RF label is detected, but not deactivated yet.
- When
- (1) Status LED on the pad blinks twice in blue color;
 - (2) Deactivation LED on the controller blinks twice in yellow color;
 - (3) Buzzer inside controller beeps twice, it means that the RF label is deactivated.

ATTENTION

Please pay attention to alert light and sound and make sure that the RF label is closer enough to the pad and deactivated well

PRECAUTIONS

1. Keep deactivator pad at least 50cm away from POS machine and computer to prevent interference and false alarm.
2. Keep deactivator pad at least 4cm(horizontal distance)and 30cm(vertical distance) from metal object to prevent interference.
3. When only one deactivator pad is connected to one port on the controller, a Short-circuit plug must be connected to another port.

SPECIFICATION

DB212 Controller

Dimension: 158×118×28mm
N. W. : 0.64kg
Input: 12~15VDC
Standby current: <120mA
Deactivation current: <200mA

DB212-A Pad

Dimension: 306×256×11.5mm
N.W.: 0.7kg

DB212-B Pad

Dimension: 305×255×25mm
N.W.: 1.0kg

Power Adaptor

Input: 100~240VAC,
50Hz/60Hz, 0.30A
Output: 12VDC, 1.25A

8.2MHZ RF DEACTIVATOR DB212

User Manual

DESCRIPTION

DB 212 is a device for deactivating 8.2MHz RF labels. Each controller has two ports for connecting with two pads working independently. When an active 8.2MHz label or tag approaches to a pad, alert light and sound will be triggered indicating appearance of the label/tag and the deactivation of the label(if it is deactivatable).

- Working frequency: 7.6-8.8MHz.
- No need to be synchronized with adjacent EAS systems.
- Height of detection: 25cm
- Height of deactivation: 15cm

COMPONENTS INSTRUCTION

Controller

Port 2(P2)

Volume adjustment

Port 1(P1)



Power port

External speaker socket

Deactivation LED

Detection LED

Power LED

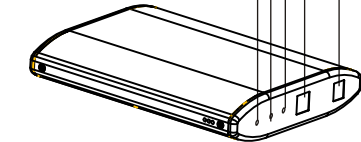

Bracket for controller

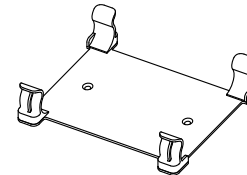

Power adaptor

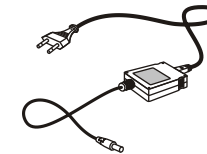

Short-circuit connector



Deactivator Pad

DB212-A

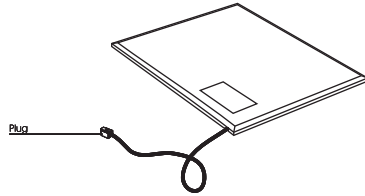

DB212-B

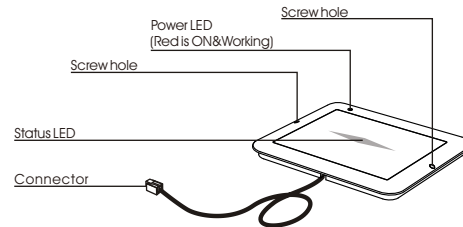

Methods to install a pad

- Flush mount
(To fix with screws onto cash counter-part of the pad is inserted into a hole)
- Mount under table
(To fix with screws under cash counter-not visible from outside)

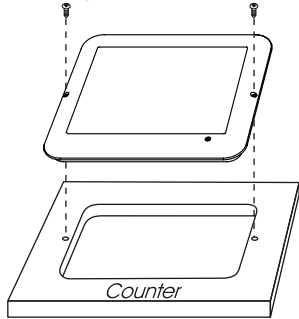

(Hole dimension 235×285mm ; R19mm)

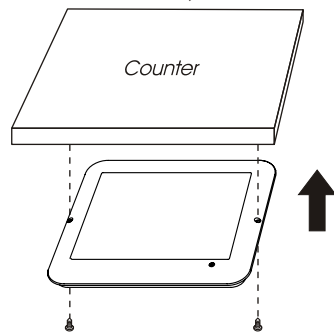

- Mount on top of cash counter
(To fix with screws onto top of cash counter directly. Better to use back plate to make the installation perfect.)

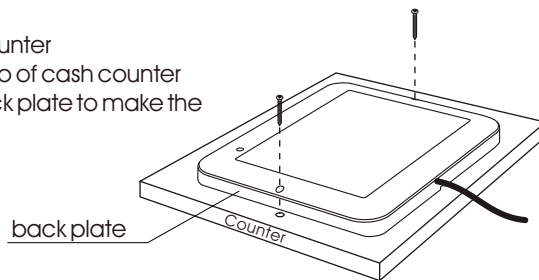

How to install the controller

- 1 Fix the bracket of controller under the counter.
- 2 Insert the controller into the bracket.

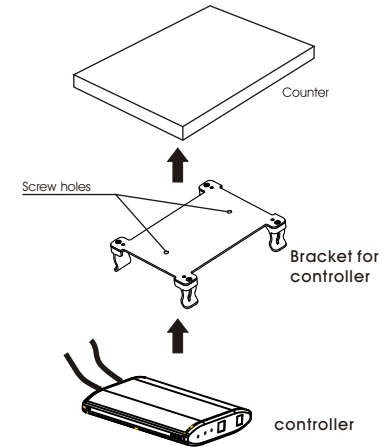

How to work with integrated deactivation coil in barcode scanner

Note: Please contact Century for confirmation about compatibility of Db212 controller and the integrated deactivation coil pre-assembled in barcode scanner.

