

1. Cautions

⚠ Please notice the following cautions. Mis-operation may lead to personal injury or equipment failure:

- 1) Do not energize the system before installation is complete. Never carry out installation activities when the system is energized.
- 2) All peripheral devices must be grounded.
- 3) It is recommended that all wires run through casing pipes which may be PVC or galvanized ones.
- 4) It is strongly recommended that the length of exposed part of any connection cable should not be longer than 4 mm. Professional clamping tools may be used to avoid unintentional contact of exposed wires to avoid short-circuit or communication failure.
- 5) It is recommended that card readers and buttons should be installed at height of 1.4m-1.5m above ground.
- 6) It is recommended to use the power supply in case for control panel, and external power supply for each lock.

2. Equipment Installation

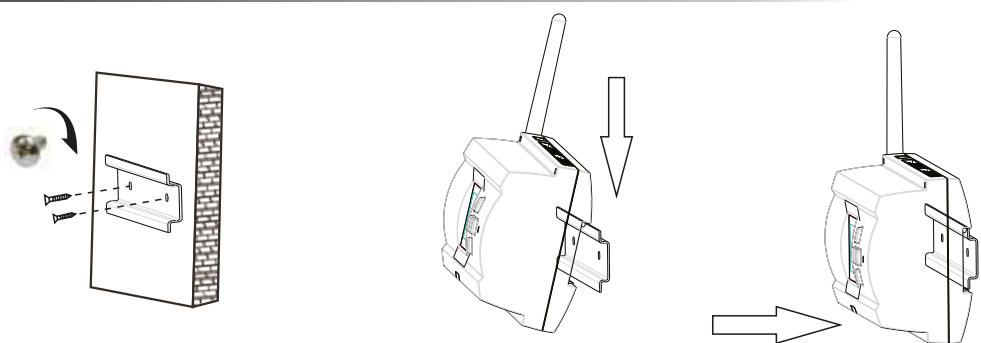

- 1 Select two of the elliptical holes on the rear iron cover. Drill two holes on the surface for fixing (Which may be on a distribution cabinet, ceiling or other weatherproof position).
- 2 Hang the equipment on the upper edge of the rear iron cover, and then press the equipment down.
- 3 Push the equipment backward to hang the entire equipment onto the rear cover.

3. Lock Connection

- 1) The access controller provides lock control output. For a lock which should be open when being energized and be closed when being de-energized, the "COM" and "NO" terminals should be used. For a lock which should be open when being de-energized and be closed when being energized, the "COM" and "NC" terminals should be used.
- 2) If the electrical lock is connected to the access control system, you need to parallel one FR107 diode (Equipped in the package) to prevent the self-inductance EMF affect the system, do not reverse the polarities.
- 3) Each relay may work under the wet mode or dry mode by setting the jumper terminal. If the 12V power supply inside the access controller uses external power supply, the output of each relay is under the "wet mode". If the external power supply uses potential free contacts, the "dry mode" should be used. please refer to Instructions for Hardware of C4-200/400 Access Controller.

* It is recommended to short 2-3 ports, the output use the "dry mode", the electronic lock use the external power supply.

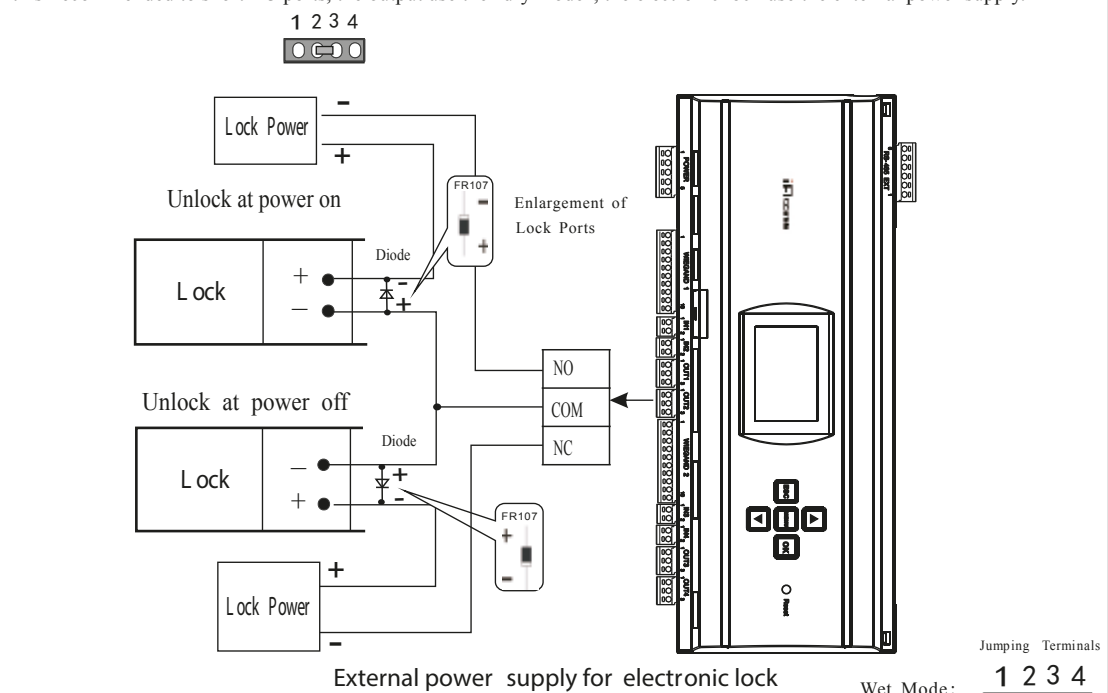

External power supply for electronic lock

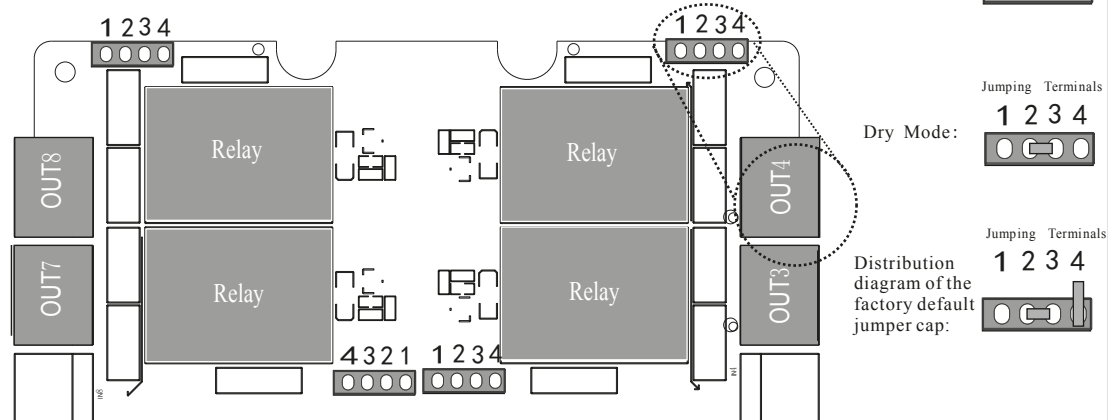
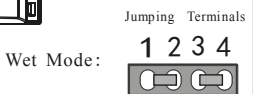

Relay output ports and jumper terminals setting (The second layer of PCB)

4. Equipment Communication

⚠ The PC software communicate with the system through two protocols (RS485 and TCP/IP) for data exchange and remote management. The communication cable should be away from high-voltage lines as far as possible. Do not keep the communication cable in parallel with power cords or bind them together.

1) TCP/IP Mode:

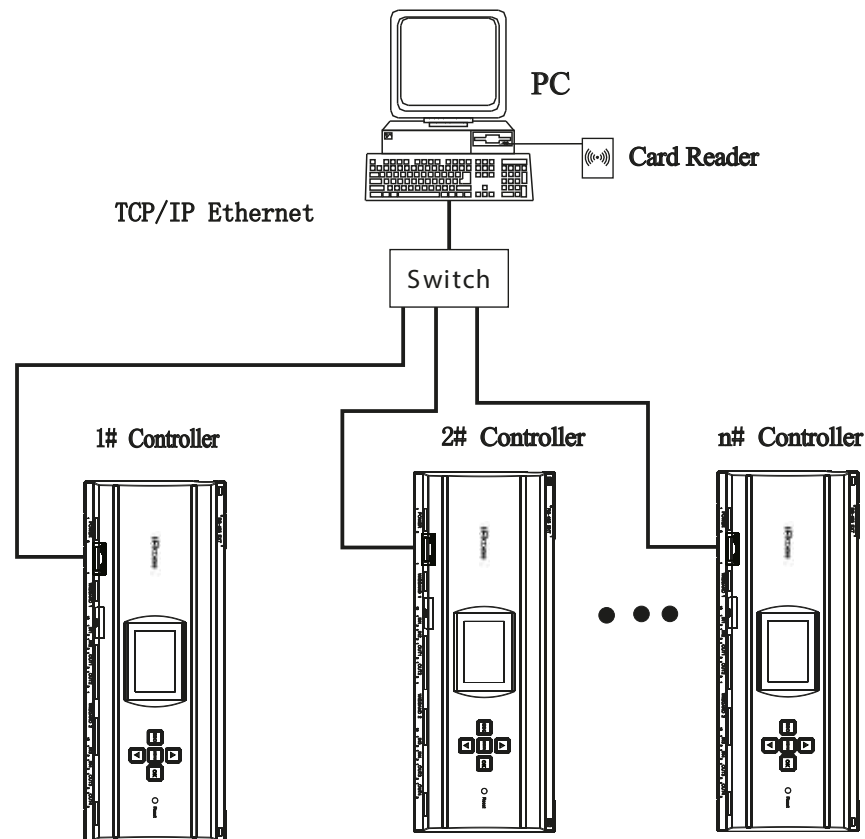

2) RS485 Mode:

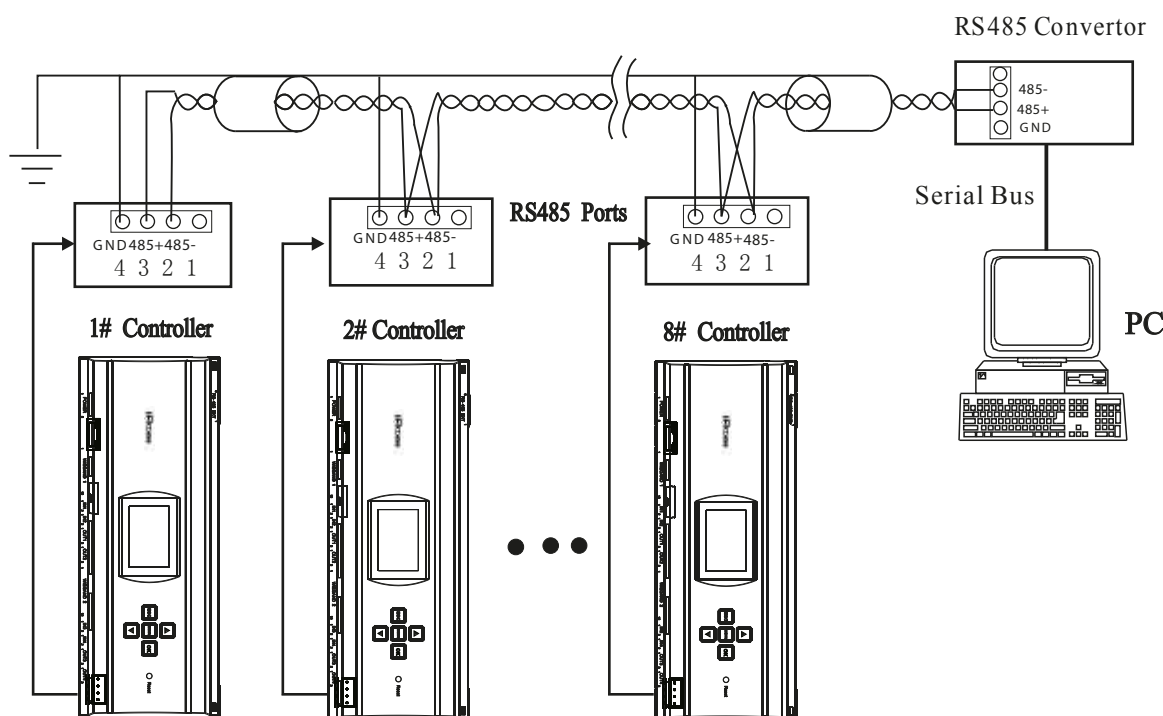

Notes:

- 1) Internationally accepted RVSP (shielded twisted-pair) wires should be used for communication to effectively avoid interference. RS485 communication wires should be connected by means of bus cascade connection.
- 2) Theoretically, in RS485 communication, one bus may be connected with 64 access controllers. It is recommended to connect with no more than 16 devices.
- 3) The recommended bus length of RS485 communication is less than 600 meters.
- 4) When the bus is longer than 300 m, to enhance the stability of communication, it is necessary to change J24 on the first layer of PCB (see the figure below) in the first and the last units (see unit 8# as shown in the figure above) to short pins 2-3. This method is equivalent to connect with a resistance of 120 ohm.

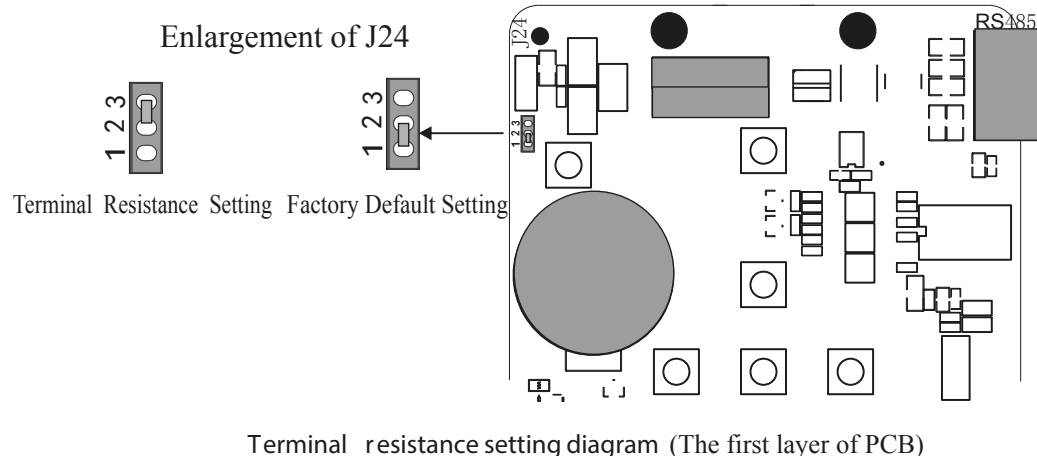

Terminal resistance setting diagram (The first layer of PCB)

5. Terminals Connection

Notes:

- 1) The auxiliary input may be connected to infrared body detectors, smoke detectors, gas detectors, window magnetic alarms, wireless exit switches, etc.
- 2) The auxiliary output may be connected to locks, monitors, alarms, door bells, etc.
- 3) The auxiliary input and the auxiliary output is set with iAccess4.0.
- 4) GPRS, WiFi and the following items indicated with "*" are optional. Please contact our business representatives or pre-sale technical support for ordering machines with GPRS and WiFi functions.
- 5) Recommended use of wires
 - A. Use 2-conducotor power cord
 - B. According to the port you connected, choose the 8,10 conductor cord communication twisted-pair sensor cable (RVVP 8*0.5mm)
 - C. Use 2-conducotor lock power cord (RVV 2*0.75mm)
 - D. Use 2-conducotor switch or magnetic power cord (RVV 2*0.5mm)

Fr ont View

Fr ont Side View

