



MINIBARS



5545 Reflex[®] SAE Class II LED, 11"

5545 Series LED microbars provide a super-compact yet powerful warning solution that offers the flexibility of either permanent or vacuum-magnet mounting. Featuring 12-24 VDC operation, the Reflex microbar uses high intensity LEDs to maximize light output. Users can select from 35 flash patterns, either via trigger wire on permanent mount models or cigarette plug with on/off and flash pattern selection switch on vacuum-magnet models.

Models

PART NO.	DOMES COLOR	ILLUMINATION	VOLTAGE	AMPS	MOUNT
5545A	Amber	Amber	12-24	0.7	Permanent
5545CA	Clear	Amber	12-24	0.7	Permanent
5545A-VM	Amber	Amber	12-24	0.7	Vacuum-Magnet
5545CA-VM	Clear	Amber	12-24	0.7	Vacuum-Magnet

Features and Benefits

- Four LED reflector modules, each containing six LEDs provide high intensity light output
- Choice of 35 flash patterns
- Cigarette plug with on/off and flash pattern selection switch (vacuum-magnet)
- Polycarbonate base & low profile lens
- Temperature Range: -22°F to +122°F (-30°C to +50°C)

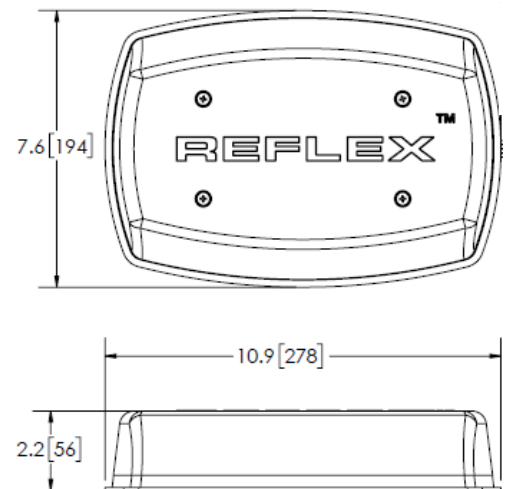

Replacement Parts

- Domes: Amber - R5545LA
Clear - R5545LC

To view the Reflex[®] Family product video, visit [YouTube.com/ECCOSafety](https://www.youtube.com/ECCOSafety)