

40FT S300 SUPERTITAN TOWER

18" H/H

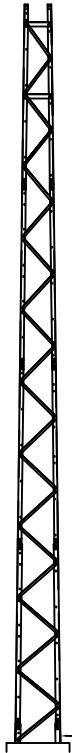

TOP SECTION #3

U S A	MAXIMUM ALLOWABLE ANTENNA AREA - PER TIA/EIA 222 REV. F					
	WIND VELOCITY RATINGS					
	NO ICE (ROUND/FLAT)			1/2" ICE (ROUND/FLAT)		
	70 mph	90 mph	100 mph	70 mph	90 mph	100 mph
	70/50	35/25	27/19	60/42	30/21	22/15

21" H/H

SECTION #4

U S A	MAXIMUM ALLOWABLE ANTENNA AREA - PER TIA/EIA 222 REV. G, CLASS 1 (NO ICE)					
	WIND VELOCITY RATINGS					
	90 mph 3sg	110mph 3sg	120 mph 3sg	3sg = 3 SECOND GUST WINDSPEED FM = FASTEST MILE WINDSPEED		
	75 mph FM	90 mph FM	100 mph FM			
	ROUND	FLAT	ROUND	FLAT	ROUND	FLAT
-	-	-	-	-	-	

24" H/H

SECTION #5

FOUNDATION LOADS:
 MAX. OVERTURNING MOMENT (K*FT) =
 MAX. SHEAR (kips) =
 MAX. AXIAL (kips) =

27" H/H

SECTION #6

30" H/H

5' EMBEDMENT SECTION
INCLUDED IN KITS

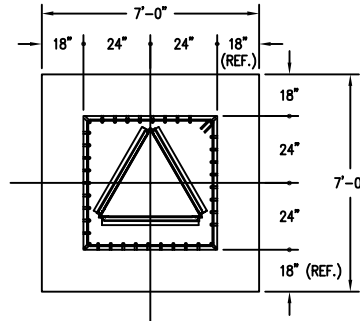

CUBIC YARDS OF CONCRETE		
PAD CONC VOL.	PIER CONC VOL.	TOTAL VOL.
2.7	2.1	4.8

FOUNDATION DESIGN (NORMAL DRY SOIL)
 DESIGN ASSUMES THAT FROST DEPTH IS LESS THAN 4'-0"

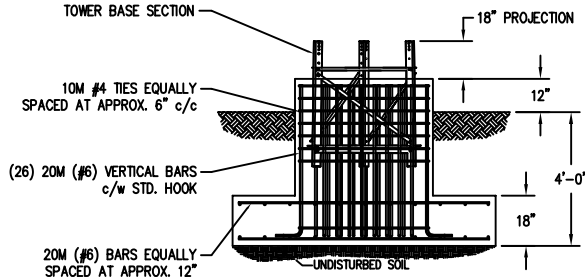

REV.	BY:	BY:	DESCRIPTION	DATE
REV.	CHK.	CHK.		

REFERENCE DRAWINGS:	
DRAWING NUMBER	DRAWING NUMBER

CONFIDENTIAL: ALL INTELLECTUAL PROPERTY RIGHTS HEREIN ARE THE PROPERTY OF TRYLON INC. ALL DUPLICATION, RECORING, DISCLOSURE OR USE IS PROHIBITED WITHOUT WRITTEN CONSENT OF TRYLON INC.

Trylon

DRAWING NO. 000001.620.0158

CUSTOMER: SITE: SCALE: 65

DATE: 02 FEB 07	BY:	CHK:	APP:
-----------------	-----	------	------

TITLE: 40FT S300 SUPERTITAN PROFILE

- NOTES: 1) KNOCK-DOWN PART NUMBER 5.94.0300.040.
 2) PRE-ASSEMBLED PART NUMBER: 5.95.0300.040.
 3) ANTENNA LOADS ARE CENTRALLY LOCATED AND BALANCED, 3-FT OR LESS ABOVE THE TOWER TOP.
 4) WIND LOADING ASSUMES (1) 1/2" TRANSMISSION LINE PER 10 SQ.FT. OF ROUND MEMBER ANTENNA AREA.