

32' T300 TITAN TOWER

(P/N 4.95.0303.000)

SECTION SPLICE

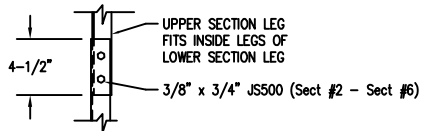

MAXIMUM ALLOWABLE ANTENNA AREA		
SURVIVAL DESIGN NO ICE (ROUND/FLAT)		
70mph WIND	85mph WIND	100mph WIND
24/16 (sqft)	13/9 (sqft)	6/4 (sqft)

FOUNDATION DESIGN (NORMAL DRY SOIL)

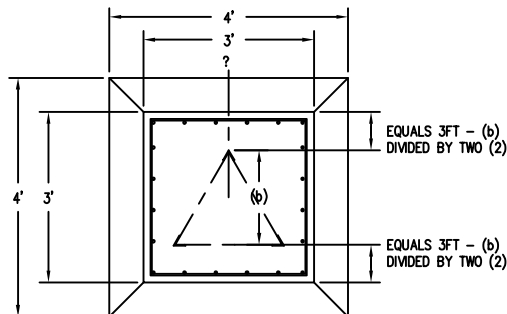

TOP ELEVATION

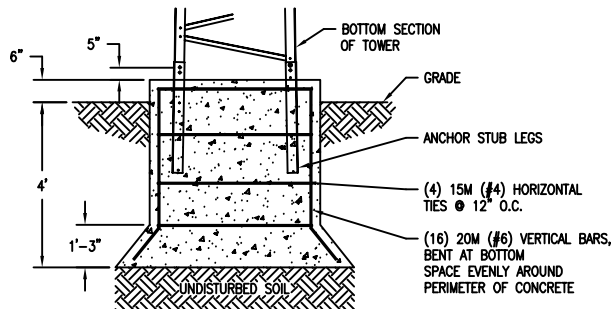
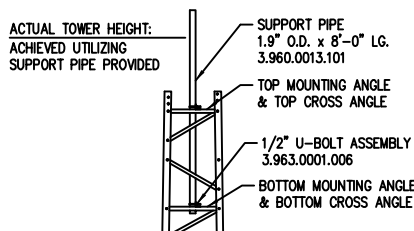

FOUNDATION LOADS:
 MAX. OVERTURNING MOMENT (K*FT) = 17.00
 MAX. SHEAR (kips) = 0.7
 DESIGN UPLIFT PER INDIVIDUAL LEG (kips) = 10.0

CONCRETE VOLUME:
 2.0 CUBIC YARDS

REV.	BY:	BY:	DESCRIPTION	DATE

REFERENCE DRAWINGS:	
DRAWING NUMBER	DRAWING NUMBER

CONFIDENTIAL: ALL INTELLECTUAL PROPERTY RIGHTS HEREIN ARE THE PROPERTY OF TRYLON INC. ALL DUPLICATION, RECORDING, DISCLOSURE OR USE IS PROHIBITED WITHOUT WRITTEN CONSENT OF TRYLON INC. CUSTOMER:		
DRAWING NO. 000001.610.0066		
DATE: 07 MAR 07	BY: MRH	CHK: CR
TITLE: 32' T300 TITAN TOWER		SCALE: 60,000 APP: JB

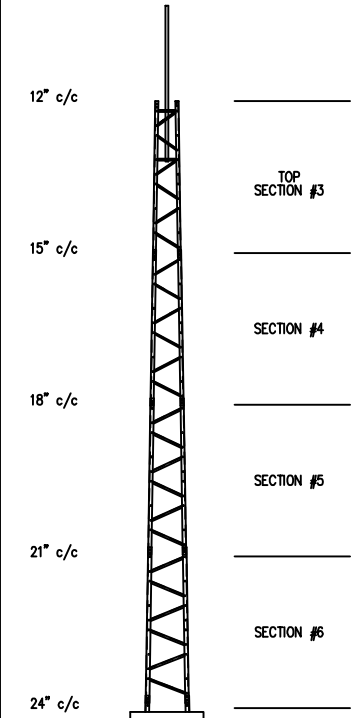

- 1) PRE-ASSEMBLED PART NUMBER 4.95.0303.000.
- 2) MAX. ANTENNA LOADS ARE CENTRALLY LOCATED AND BALANCED, 3FT OR LESS ABOVE THE TOWER TOP.
- 3) "SURVIVAL" DESIGN IN NOT THE SAME AS EIA-222. FOR EIA COMPLIANCE SEE OUR SUPERTITAN MODELS.
- 4) MINIMUM 32ksi YIELD FOR ALL COMPONENTS.
- 5) CONSTRUCTED FROM PASSIVATED G-90 COAT GALVANIZED STEEL SHEET.
- 6) TOWERS COME ASSEMBLED IN 8FT SECTIONS.
- 7) TOP SUPPORT PIPE IS INCLUDED.
- 8) FOR OPTIONAL ROCK BOLT FOUNDATION SEE DWG 000001.610.0033 AND 000001.610.0021.