



# VM-1 Technical Reference Manual

P/N 3101890-EN • REV 006 • ISS 21JUN18



**Copyright** © 2018 United Technologies Corporation. All rights reserved.

This document may not be copied in whole or in part or otherwise reproduced without prior written consent from United Technologies Corporation, except where specifically permitted under US and international copyright law.

**Trademarks and patents** The Kidde name and logo are trademarks of United Technologies Corporation  
Other trade names used in this document may be trademarks or registered trademarks of the manufacturers or vendors of the respective products.

**Version** This document applies to VM-1 with C-CPU firmware version 1.x.

**Contact information** For contact information, see [www.kiddelifesafety.com](http://www.kiddelifesafety.com).

# Content

Important information iii

## Chapter 1

### **Introduction 1**

About this manual 2  
Intended audience 2  
Fire alarm system limitations 2

## Chapter 2

### **Product description 3**

General description 4  
System hardware capabilities 5  
Panel components 8  
Minimum system requirements 12  
VM-1 user interface 12  
Event message queues 17  
User access levels 18  
Command menus 20

## Chapter 3

### **Operating instructions 29**

Operating states 31  
Control panel power up 34  
Utilizing the user interface keypads 35  
Silencing the panel buzzer 36  
Silencing alarm signals 37  
Acknowledging events 37  
Resetting the fire alarm system 38  
Restarting the fire alarm system 38  
Clearing the alarm history 38  
Viewing event message details 39  
Viewing reports 40  
Disabling and enabling devices 43  
Disabling and enabling option cards 44  
Disabling and enabling logic groups 45  
Disabling and enabling system time controls 46  
Testing the system and devices 46  
Changing output states 47  
Switching the smoke detector alarm sensitivity thresholds 49  
Changing event message routing 50  
Changing Access Level passwords 50  
Changing the LCD screen language 51  
Downloading a database 51  
Using a TCP/IP connection to read from the panel 54  
Setting the system time and date 54  
Configuring holiday lists 55  
Control-indicating module 56

## Chapter 4

### **Supplementary applications 59**

Digital audio subsystem 60  
Remote annunciation 67  
FireWorks communication 72  
IP dialer and email communication 72

<b>Chapter 5</b>	<b>Installation 75</b>
	UL 864 notification appliance circuit (NAC) signal synchronization 76
	Creating an initial startup database 76
	System installation sequence 77
	Component installation 79
	Preliminary field wiring testing 89
	VM-DACT Dual Line Dialer Card 90
	Connecting a MIR-PRT/S serial printer 95
	Connecting a CDR-3 for coded tone output 99
	R-Series and K-R-Series annunciator DIP switch settings 104
	Runtime errors 105
<b>Chapter 6</b>	<b>Preventive maintenance and testing 107</b>
	Visual inspections 108
	Routine maintenance and tests 109
	System trouble and maintenance log 121
	Record of completion 122
<b>Chapter 7</b>	<b>Service and troubleshooting 123</b>
	System repairs 124
	Precautions 124
	Panel restart problems 125
	Hardware troubleshooting 125
	Pseudo points 134
	Understanding VM signaling line circuits 146
	Loop controller troubleshooting 155
	Using the Configuration Utility diagnostics tools 157
	Using HyperTerminal to troubleshoot the system 164
<b>Appendix A</b>	<b>System calculations 167</b>
	Network data riser limits 168
	Signaling line circuit wire length 170
	Notification appliance circuit calculations 177
	25 or 70 VRMS NAC wire length 182
	Cabinet battery 183
	Fiber optic cable worksheet 187
<b>Appendix B</b>	<b>Addresses 189</b>
	Address formats 190
	Card numbering 190
	Hardware layer device addresses 192
	Operator layer device address 193
	Remote annunciator device addresses 194
	Logic group addresses 202
<b>Appendix C</b>	<b>Programming options 203</b>
	Programming options 204
	<b>Glossary 207</b>
	<b>Index 211</b>

# Important information

## Regulatory information

This product has been designed to meet the requirements of NFPA 72 *National Fire Alarm Code*, UL 864 *Standard for Control Units for Fire Protective Signaling Systems*, and ULC S527 *Standard for Control Units for Fire Alarm Systems*.

## Limitation of liability

To the maximum extent permitted by applicable law, in no event will United Technologies Corporation be liable for any lost profits or business opportunities, loss of use, business interruption, loss of data, or any other indirect, special, incidental, or consequential damages under any theory of liability, whether based in contract, tort, negligence, product liability, or otherwise. Because some jurisdictions do not allow the exclusion or limitation of liability for consequential or incidental damages the preceding limitation may not apply to you. In any event the total liability of United Technologies Corporation shall not exceed the purchase price of the product. The foregoing limitation will apply to the maximum extent permitted by applicable law, regardless of whether United Technologies Corporation has been advised of the possibility of such damages and regardless of whether any remedy fails of its essential purpose.

Installation in accordance with this manual, applicable codes, and the instructions of the authority having jurisdiction is mandatory.

While every precaution has been taken during the preparation of this manual to ensure the accuracy of its contents, United Technologies Corporation assumes no responsibility for errors or omissions.

## Advisory messages

Advisory messages alert you to conditions or practices that can cause unwanted results. The advisory messages used in this document are shown and described below.

---

**WARNING:** Warning messages advise you of hazards that could result in injury or loss of life. They tell you which actions to take or to avoid in order to prevent the injury or loss of life.

---

**Caution:** Caution messages advise you of possible equipment damage. They tell you which actions to take or to avoid in order to prevent the damage.

---

**Note:** Note messages advise you of the possible loss of time or effort. They describe how to avoid the loss. Notes are also used to point out important information that you should read.

## VM-1 FCC compliance

This equipment can generate and radiate radio frequency energy. If the equipment is not installed in accordance with this manual, it may cause interference to radio communications. This equipment has been tested and found to comply with the limits for Class A computing devices pursuant to Subpart B of Part 15 of the FCC Rules. These rules are designed to provide reasonable protection against such interference when this equipment is operated in a commercial environment. Operation of this equipment is likely to cause interference, in which case the user, at his own expense, will be required to take whatever measures may be required to correct the interference.

# VM-DACT FCC compliance

## Cautions

- To ensure proper operation, this dialer must be installed according to the enclosed installation instructions. To verify that the dialer is operating properly and can successfully report an alarm, it must be tested immediately after installation, and periodically thereafter, according to the enclosed test instructions.
- In order for the dialer to be able to seize the phone line to report an alarm or other event when other customer equipment (telephone, answering system, computer modem, etc.) connected to the same line is in use, the dialer *must* be connected to a properly installed RJ-31X jack. The RJ-31X jack must be connected in series with, and ahead of, all other equipment attached to the same phone line. Series installation of an RJ-31X jack is depicted in the wiring diagram. If you have any questions concerning these instructions, you should consult your telephone company or a qualified installer.

## Testing

When programming emergency numbers or making test calls to emergency numbers, remain on the line and briefly explain to the dispatcher the reason for the call. Perform programming and testing activities in the off-peak hours, such as early morning or late evenings.

## Compliance

- **For equipment approved before July 23, 2001:** This dialer complies with Part 68 of the FCC rules. A label attached to the dialer contains, among other information, the FCC registration number and ringer equivalence number (REN) for this equipment. If requested, this information must be provided to the telephone company.

**For equipment approved after July 23, 2001:** This dialer complies with Part 68 of the FCC rules and the requirements adopted by the Administrative Council for Terminal Attachments (ACTA). A label attached to the dialer contains, among other information, a product identifier in the format US:AAAEQ##TXXXX. If requested, this information must be provided to the telephone company.

- The plug and jack used to connect the dialer to the premises wiring and telephone network must comply with the applicable FCC Part 68 rules and requirements adopted by ACTA. The dialer must be connected to a compliant RJ-31X or RJ-38X jack using a compliant cord. If a modular telephone cord is supplied with the dialer, it is designed to meet these requirements. See installation instructions for details.
- A ringer equivalence number (REN) is used to determine how many devices you can connect to a telephone line. If the total REN value for all devices connected on a telephone line exceeds that allowed by the telephone company, the devices may not ring on an incoming call. In most (but not all) areas the total REN value should not exceed 5.0. To be certain of the total REN value allowed on a telephone line, contact the local telephone company.

For products approved after July 23, 2001, the REN is part of the product identifier in the format US:AAAEQ##TXXXX. The digits ## represent the REN without a decimal point. Example: 03 is an REN of 0.3. For earlier products the REN is listed separately.

- If the dialer is harming the telephone network, the telephone company will notify you in advance that temporary discontinuance of service may be required. If advance notice is not practical, the telephone company will notify you as soon as possible. You will also be advised of your right to file a complaint with the FCC, if you believe it is necessary.
- The telephone company may make changes to its facilities, equipment, operations, or procedures that could affect the operation of the dialer. If this happens, the telephone company will provide advance notice in order for you to make necessary modifications to maintain uninterrupted service.
- If you are experiencing problems with the dialer, contact the manufacturer for repair or warranty information. If the dialer is harming the telephone network, the telephone company may request that you disconnect the dialer until the problem is resolved.

- The dialer contains no user serviceable parts. In case of defects, return the dialer for repair.
- You may *not* connect the dialer to a public coin phone or a party line service provided by the telephone company.

## VM-DACT Industry Canada information

**Note:** The Industry Canada label identifies certified equipment. This certification means that the equipment meets certain telecommunications network protective, operational, and safety requirements. Industry Canada does not guarantee the equipment will operate to the user's satisfaction.

Before installing this equipment, users should ensure that it is permissible to be connected to the facilities of the local telecommunications company. The equipment must also be installed using an acceptable method of connection. The customer should be aware that compliance with the above conditions may not prevent degradation of service in some situations.

Repairs to certified equipment should be made by an authorized Canadian maintenance facility designated by the supplier. Any repairs or alterations made by the user to this equipment, or equipment malfunctions, may give the telecommunications company cause to request the user disconnect the equipment.

---

**Caution:** Users should not attempt to make connections themselves, but should contact the appropriate electric inspection authority, or electrician, as appropriate

---

Users should ensure for their own protection that the electrical ground connections of the power utility, telephone lines, and internal metallic water pipe system, if present, are connected together. This precaution may be particularly important in rural areas.

**Note:** The Load Number (LN) assigned to each terminal device denotes the percentage of the total load to be connected to a telephone loop which is used by the device, to prevent overloading. The termination on a loop may consist of any combination of devices subject only to the requirements that the sum of the Load Numbers of all the devices does not exceed 100.



# Chapter 1

# Introduction

## **Summary**

This chapter provides information about this manual and other related documentation.

## **Content**

About this manual 2

Intended audience 2

Fire alarm system limitations 2

## About this manual

This manual provides information on how to install, program, and operate a VM-1 life safety control panel. It is organized as follows:

**Chapter 1, Introduction:** Provides information about this manual and other related documentation.

**Chapter 2, Product description:** Provides technical descriptions of the control panel and its operation. It also provides descriptions of the command menus.

**Chapter 3, Operating instructions:** Provides instructions for operating the fire alarm system from the control panel user interface. It is intended for those who might be expected to operate the control panel in a fire alarm emergency.

**Chapter 4, Supplementary applications:** Provides technical descriptions of supplementary applications that can expand system capabilities.

**Chapter 5, Installation:** Provides installation information for system components and applications. It is intended for those trained and authorized to maintain the fire alarm system.

**Chapter 6, Preventive maintenance and testing:** Provides maintenance schedules and testing procedures for fire alarm system. It is intended for those trained and authorized to maintain the fire alarm system.

**Chapter 7, Service and troubleshooting:** Provides instructions for servicing and troubleshooting the fire alarm system. It is intended for those trained and authorized to maintain the fire alarm system.

**Appendix A, System calculations:** Provides worksheets for sizing standby batteries, and for calculating the maximum wire lengths for notification appliance circuits and intelligent addressable loops.

**Appendix B, Addresses:** Provides a comprehensive list of addresses to use as a general reference.

**Appendix C, Programming options:** Summarizes the operation of the system.

## Intended audience

The intent of this document is to provide trained and authorized personnel with technical, operational, service, and maintenance information.

## Fire alarm system limitations

The purpose of an automatic fire alarm system is to provide early detection and warning of a developing fire. There are a number of uncontrollable factors that can prevent or severely limit the ability of an automatic fire alarm system to provide adequate protection. As such, an automatic fire alarm system cannot guarantee against loss of life or loss of property.

Two main causes of system failures are improper installation and poor maintenance. The best way to minimize these types of system failures is to have only trained fire alarm system professionals design, install, test, and maintain your fire alarm system in accordance with national and local fire codes.

Fire alarm systems will not operate without electrical power. As fires frequently cause power interruption, we suggest that you discuss ways to safeguard the electrical system with your local fire protection specialist.

# Chapter 2

## Product description

### Summary

This chapter provides descriptions of the control panel and its components, and the operator interface controls, indicators, and commands.

### Content

General description	4	Buzzer indicator	15
System overview	4	LCD screen indications	15
System hardware capabilities	5	Event message queues	17
Control panel architecture	5	User access levels	18
Electronics chassis assembly	7	Command menus	20
System size	7	Main Menu	20
Programmable features	8	Status Menu	20
Panel components	8	Enable Menu	21
Standard control panel components	8	Disable Menu	21
Control panel options	9	Activate Menu	22
Control panel accessories	11	Restore Menu	24
Minimum system requirements	12	Reports Menu	25
VM-1 user interface	12	Program Menu	26
Operator controls and indicators	13	Test Menu	27
System status indicators	14		

## General description

This topic provides a general description of the system control panel, hardware capabilities, option cards, panel components, accessories, and remote annunciator panels.

### System overview

The VM-1 can operate as a stand-alone control panel or in a 24-node peer-to-peer Class B or Class A / Class X VM-1 life safety network.

The VM-1 user interface contains operator controls and indicators that make you aware of event activations and provide you with the ability to take action. When an event occurs, the alarm state on the VM-CPU main board changes and activates the control panel LEDs and buzzer, and displays an event message on the 240 × 320 pixel liquid crystal display (LCD) screen. Alarm, supervisory, trouble, and monitor event messages provide information that allows you to locate the active point and respond accordingly. The panel also gives you the ability to access message details and system reports, enable and disable devices and groups, activate and restore sensitivity settings and message routing, test system devices, and to perform several other tasks.

**Figure 1: VM-1 control panel, front view**

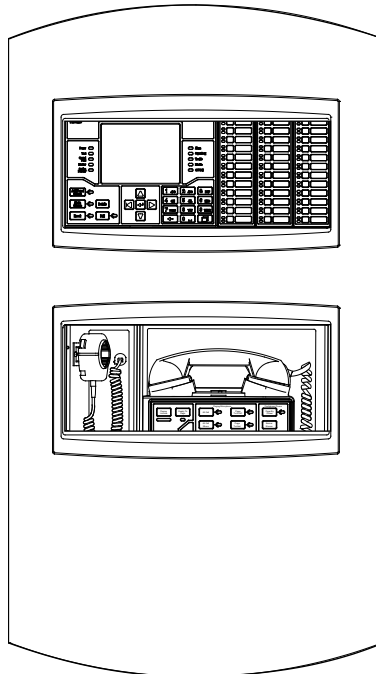

A standard VM-1 control panel consists of a cabinet backbox and door, a PS10-4B Power Supply Card, and a VM-ELEC Chassis Electronics Assembly. See Figure 2 for an exploded view of the cabinet.

The control panel can be mounted directly on the finished wall surface (surface mount) or partially recessed in a wall cavity (semiflush mount). Semiflush mounted cabinets require the TRIM6 Trim Kit that is ordered separately.

You can add accessories to your life safety system that can expand its functionality. See “Panel components” on page 8 for a list of option cards and accessories.

## System hardware capabilities

In its basic configuration, the VM-1 supports:

- 250 addressable devices
- 4 Class B notification appliance or auxiliary power output circuits
- 30 LCD or LED remote annunciators with common controls
- 3,840 LED indicators
- 1,920 manual override control switches

With the proper hardware options, the VM-1 can support:

- 1,000 addressable alarm signal initiating devices
- 4 Class B notification appliance or auxiliary power output circuits
- 4 Class A notification appliance or auxiliary power output circuits
- 3 reverse polarity outputs
- 2 dialer outputs
- Live voice and prerecorded audio messaging
- Two-way firefighter telephone communication
- 30 LCD or LED remote annunciators with common controls
- 3,912 LED indicators
- 1,956 manual override controls
- Remote connection to a 24-node VM-1 life safety network

## Control panel architecture

Figure 2 provides an exploded view of the standard VM-1 control panel components. See “Panel components” on page 8 for a complete list and description of panel components, option cards, and accessories.

### Control panel

VM-1 control panel models are listed below.

<b>Model</b>	<b>Description</b>
VM-1S	Fire alarm control panel, silver door
VM-1R	Fire alarm control panel, red door

**Figure 2: VM-1 control panel, exploded view**

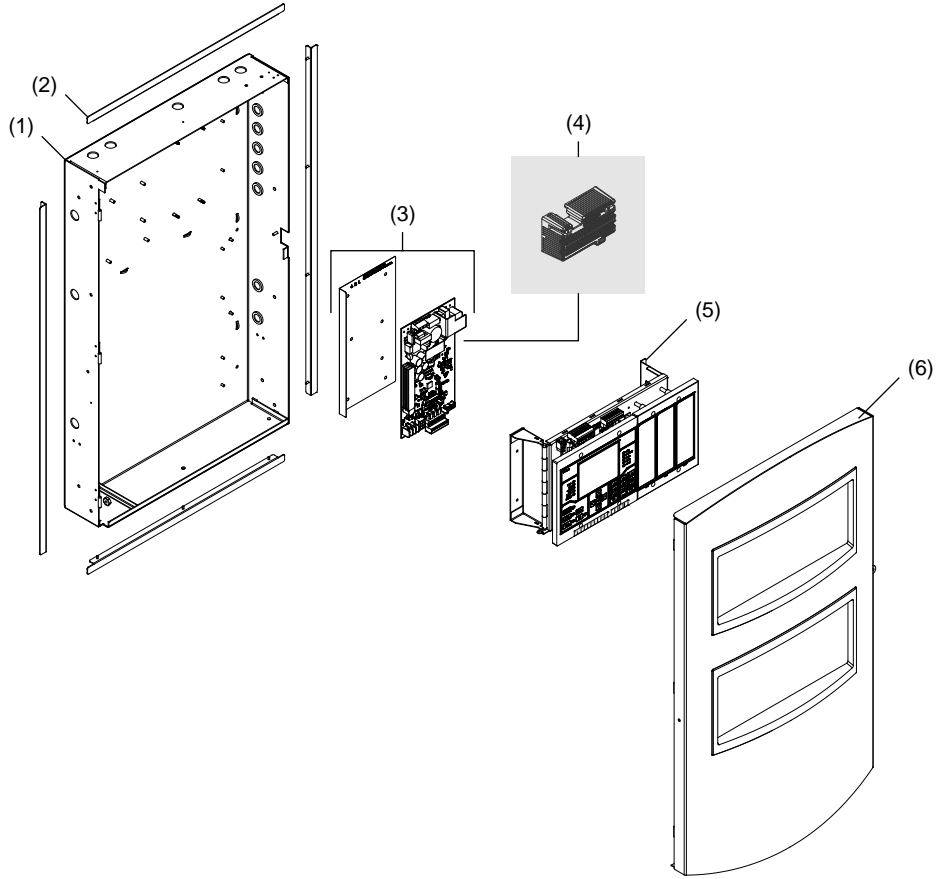

- (1) CAB6B Backbox
- (2) TRIM6 Trim Kit (optional)
- (3) PS10-4B Power Supply Board

- (4) Protective cage (installed for ULC only)
- (5) VM-ELEC Chassis Electronics Assembly
- (6) VMD(G/R) Door

## Electronics chassis assembly

Figure 3 provides an exploded view of the VM-ELEC.

**Figure 3: VM-ELEC electronic chassis assembly, exploded view**

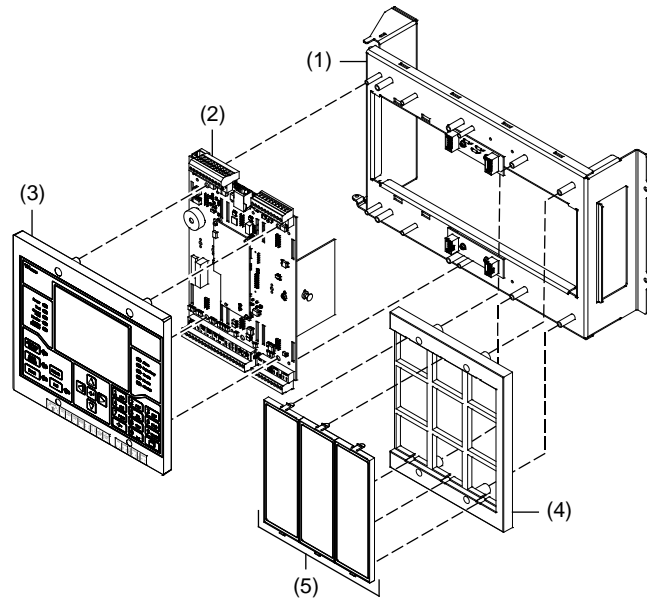

- (1) Electronics chassis
- (2) VM-CPU Main Board
- (3) VM-LCD User Interface

- (4) Mounting frame
- (5) Filler plates

## System size

Table 1 lists the maximum hardware capabilities for a single VM-1 control panel.

**Table 1: Control panel hardware capabilities**

Item	Maximum capacity
Signaling line circuits (SLC)	4 [1]
Addressable detectors	500 (125 detectors each SLC)
Addressable modules	500 (125 single address modules each SLC)
Notification appliance circuits	4 Class B or Class A [2]
Auxiliary power circuits	4 continuous, programmable 1 continuous or resettable
Remote annunciators	30 (30 sets of system controls and 3,840 LED indicators)
Graphic annunciators	30 (30 sets of system controls, 1,920 switches, and 3,840 LED indicators)
Reverse polarity outputs	3
Networked fire alarm control panels	24

[1] One built-in dual loop controller on the CPU plus one dual loop controller module installed on the chassis rail.

[2] A CLA-PS10 Class A Adapter Card must be installed to convert the Class B notification appliance circuits to Class A notification appliance circuits.

## Programmable features

The VM-1 control panel includes a number of programmable features that can be configured using the VM Configuration Utility (VM-CU).

- **Groups:** Allows you to create a collection of devices that are grouped in the database in order to provide a group response that is separate from that of its member devices.
- **Custom audio messages:** Allows you to record custom audio messages for broadcasting through an optional emergency voice/alarm system.
- **Automatic alarm signal silence timer:** Determines how long alarm signals remain active if they are not silenced manually. Possible values are 0 to 60 minutes.
- **Reset inhibit timer:** Ensures alarm signals are active for at least 1 to 60 minutes before you can silence them or reset the system.
- **AC power fault delay timer:** Delays reporting AC power failure off-premises.
- **Waterflow silence:** Allows you to silence alarm signals when a waterflow device is activated.
- **Zone re-sound inhibit:** Prevents silenced signals from re-sounding when another device in the same zone group activates.
- **Two-stage timer:** Specifies the time you want to allow for two-stage operation. The timer starts on the first alarm event.
- **Trouble re-sound:** Determines how long panel trouble buzzers can remain silent with an active event on the panel. The buzzer re-sounds when the time is exceeded. By default, this timer is set to 24 hours.
- **Message routing:** Routes messages to panels through network routing, or to panels and printer ports using message annunciation routing.
- **Time controls:** Provide for the automatic starting and stopping of system events based on time and date. Time controls run in the background and do not require any operator action.

## Panel components

This section describes the components that can be installed in the control panel.

### Standard control panel components

**Table 2: Control panel standard components**

Model	Description
CAB6B	Backbox: Provides the housing for locally installed VM-1 components. See installation sheet P/N 3101764-EN for specifications.
PS10-4B	Power supply board: Provides the required power and related supervision functions for the control panel, as well as filtered and regulated power, and 24 VDC for ancillary equipment. Installs on the backbox. See installation sheet P/N 3101774-EN for specifications.

Model	Description
VM-ELEC	<p>Electronics Chassis: Provides the mounting, internal power, and audio and data distribution for the main board, user interface, and supporting cards. Includes a preinstalled VM-CPU Main Board, VM-LCD User Interface and three blank filler plates. Installs on the backbox. See installation sheet P/N 3101780-EN for specifications.</p> <p>The preinstalled VM-CPU processes all information from modules installed in the same cabinet and from other control panels on the VM-1 life safety network. The VM-CPU provides common relay outputs, two signaling line circuits (loops), network data and digital audio risers, panel programming inputs, and connection to R-Series or K-R-Series remote annunciators. One VM-SLC signaling line circuit card is preinstalled on the board. See installation sheet P/N 3101798-EN for specifications.</p> <p>The preinstalled VM-LCD provides the user interface for the fire alarm control panel. See installation sheet P/N 3101781-EN for specifications.</p> <p>The preinstalled filler plates can be replaced with up to three D12LS-VM Control-Indicating modules.</p>
VMD(G/R)	Cabinet door: Provides two viewing windows and is secured with a key lock. See installation sheet P/N 3101779-EN for specifications.

## Control panel options

**Note:** Option cards and modules are ordered separately and installed in the field.

**Table 3: Control panel option cards**

Model	Description
CLA-PS10	Class A Adapter Card: Converts the Class B notification appliance/auxiliary power circuits on the PS10-4B Power Supply Card to Class A notification appliance circuits. Installs on the PS10-4B. See installation sheet P/N 3101776-EN for specifications.
VM-NOC	RS-485 Network Option Card: Provides the interface for both the network data riser and a digital audio riser. Provides connection to other VM-1 control panels to form an VM-1 life safety network (24-node max.). Installs on the VM-CPU. See installation sheet P/N 3101782-EN for specifications.
VM-SLC	Signaling Line Circuit Card: Provides a Class B, Class A, or Class X signaling line circuit and resettable 24 VDC for powering conventional two-wire smoke detector circuits on VM-1 compatible modules. Installs on the VM-CPU. See installation sheet P/N 3101785-EN for specifications.
VM-SLC-HC	Signaling Line Circuit Card: Optional replacement card for the VM-SLC for installations where the signaling line circuit has more than 90 isolators and isolator bases (with V-Series sensors installed). Provides a Class B, Class A, or Class X signaling line circuit and resettable 24 VDC for powering conventional two-wire smoke detector circuits on GSA modules. Installs on the VM-CPU. See installation sheet P/N 3102327-EN for specifications.
VM-SLCXB	Signaling Line Circuit Expansion Card: Provides up to two Class B, Class A, or Class X signaling line circuits and resettable 24 VDC for powering conventional two-wire smoke detector circuits on VM-1 compatible modules. One VM-SLC signaling line circuit card is preinstalled on the VM-SLCXB. A second SLC card must be added to provide the additional device loop. Installs on the VM-ELEC electronics chassis. See installation sheet P/N 3102128-EN for specifications.

Model	Description
VM-NOCF	Fiber Optic Network Option Module: Provides a fiber optic or combination fiber optic and RS-485 communication path for VM-1 control panels. Installs on the VM-CPU and on a half-footprint space on the CAB6B backbox. See installation sheet, P/N 3101783-EN for specifications.
VM-ETH1	Ethernet Adapter Card: Provides a standard 10/100BaseT Ethernet network connection for panel programming and diagnostics. The card also provides transmission of system events to a computer running FireWorks. Installs on the VM-CPU. See installation sheet P/N 3101794-EN for specifications.
VM-ETH2	Ethernet Adapter Card: Provides a standard 10/100BaseT Ethernet network connection for panel programming and diagnostics. The card also provides transmission of system events to a computer running FireWorks and central monitoring station (CMS). Installs on the VM-CPU. See installation sheet P/N 3101794-EN for specifications.
VM-ETH3	Ethernet Adapter Card: Provides a standard 10/100BaseT Ethernet network connection for panel programming and diagnostics. The card also provides transmission of system events to a computer running FireWorks, CMS, and SMTP email server. Installs on the VM-CPU. See installation sheet P/N 3101794-EN for specifications.
VM-DACT	Dual line dialer card. Provides dialer communications between the VM-1 control panel and remote locations over telephone lines. Installs on the VM-ELEC hardware layer. See installation sheet P/N 3101786-EN for specifications.
VM-PMI	Paging Microphone Interface. Adds controls for emergency voice/alarm communications to a VM-1 control panel. Consists of an audio mounting bracket, EAEC Emergency Audio Evacuation Controller card, audio enclosure, and paging microphone. Installs on the CAB6B backbox. See installation sheet P/N 3101788-EN for specifications.
VM-MFK	Master Firefighter Telephone Kit. Adds two-way firefighter telephone capability to a VM-PMI Paging Microphone Interface to comprise the fire command center. Consists of a firefighter telephone, hook-switch card, and telephone controller card. Installs on the VM-PMI. See installation sheet P/N 3101790-EN for specifications.
ACHS	Audio Channel Selector Card. Converts digital audio from an EAEC card into an analog preamp signal. The control panel supports up to three ACHS cards. Installs on the VM-PMI audio mounting bracket. See installation sheet P/N 3101791-EN for specifications.
D12LS-VM	Control-indicating module. Provides an additional operator interface using an annunciator strip with 12 groups of two LED-switches. Installs on the VM-ELEC operator layer. See installation sheet P/N 3101793-EN for specifications.

## Control panel accessories

**Table 4: Control panel accessories**

Model	Description
VM-REMICA	Remote Paging Microphone: Provides remote paging capability throughout a building or campus. Each VM-REMICA has two inputs for connecting other remote microphone units. The paging circuit supports up to 63 interconnected remote paging stations. See installation sheet P/N 387466 for specifications.
R-Series / K-R-Series remote annunciator	<p>Remote annunciators: Provide status indication and common controls for the control panel. The following annunciators and interface cards can be used with the VM-1 fire alarm control panel.</p> <ul style="list-style-type: none"> <li>• RLCD-C / K-RLCD-C Remote Annunciator: Provides LCD text annunciation with common controls. See installation and operation guide P/N 3101969-EN for specifications.</li> <li>• RLCD / K-RLCD Remote Annunciator: Provides LCD text annunciation without common controls. See installation and operation guide P/N 3101969-EN for specifications.</li> <li>• RLED-C / K-RLED-C Remote Annunciator: Provides LED zone annunciation with common controls. See installation and operation guide P/N 3101969-EN for specifications.</li> <li>• RLED24 / K-RLED24 Remote Annunciator Expander: Provides 24 red-over-yellow pairs of LEDs (12 pairs configurable as yellow-over-yellow). See installation and operation guide P/N 3101969-EN for specifications.</li> <li>• GCI and GCI-NB Graphic Annunciator Interface Cards: Connect a compatible UL/ULC Listed fire alarm control panel to an LED-based graphic annunciator. See installation sheet P/N 3100973-EN for specifications.</li> <li>• GCIX Graphic Annunciator Expander Card: Provides additional switch inputs and LED outputs on GCI(-NB) card-based graphic annunciators. See installation sheet P/N 3101296-EN for specifications.</li> </ul>
GSA-REL	Releasing Module: Actuates solenoid valves that control the release of water or chemical extinguishing agents in support of fire suppression applications such as sprinkler systems and automatic fire extinguishing systems. See technical reference manual P/N 387515 for specifications.
RPM	Reverse Polarity Module: Provides three reverse polarity transmitters: one for system common alarm; one for system common trouble; and one for system common supervisory. Installs on a half-footprint space on the CAB6B backbox. See installation sheet P/N 3100430 for specifications.
SIGA-AA30	30-watt audio amplifier: Dual input, switch mode amplifier capable of producing a 25 or 70 VRMS audio signal from a 1 or 25 VRMS input. See installation sheet P/N 387343-ML for specifications.
SIGA-AA50	50-watt audio amplifier: Dual input, switch mode amplifier capable of producing a 25 or 70 VRMS audio signal from a 1 or 25 VRMS input. See installation sheet P/N 387343-ML for specifications.
CTM	City Tie Module: Provides a single municipal box connection for activating a local energy type master box that is connected to a public fire alarm reporting system. See installation sheet P/N 3101025 for specifications.
3-TAMP	Tamper Switch: Detects an open VM-1 control panel door. Installs on the CAB6B backbox. See installation sheet P/N 387422 for specifications.

Model	Description
CDR-3	Bell Coder: Provides coded outputs in response to alarm conditions for systems requiring march time, temporal, or unique coded outputs in separate zones and decodes alarm codes embedded in printer messages received through RS-232 input. Installs on a half footprint space on the CAB6B backbox. See installation sheet P/N 3100023 for specifications.
MIR-PRT/S	Serial Printer: Can be connected to the fire alarm control panel to print system events such as status changes, active events, or reports. See installation sheet P/N 3100989-EN for specifications.
TRIM6	Trim Kit: Provides a trim ring for a semiflush mounted CAB6B backbox. See installation sheet P/N 3101778-EN for specifications.

## Minimum system requirements

The VM-1 can operate as a stand-alone control panel or as part of a 24-node VM-1 life safety network. The VM-1 is listed for the following types of service:

- Commercial protected premises fire alarm control unit
- Smoke control system
- Releasing device control unit
- Emergency communication and relocation

For a list of components required to meet each service listing, refer to the *VM-1 UL Listing Document* (P/N 3101753-EN).

## VM-1 user interface

The VM-LCD is the user interface component of the VM-1 control panel. The interface is comprised of an alphanumeric LCD screen, operator controls, and LED status indicators.

Figure 4 shows the functional areas of the user interface. See Table 5 on page 13 and Figure 6 on page 17 for descriptions of each interface component.

Figure 4: VM-1 user interface

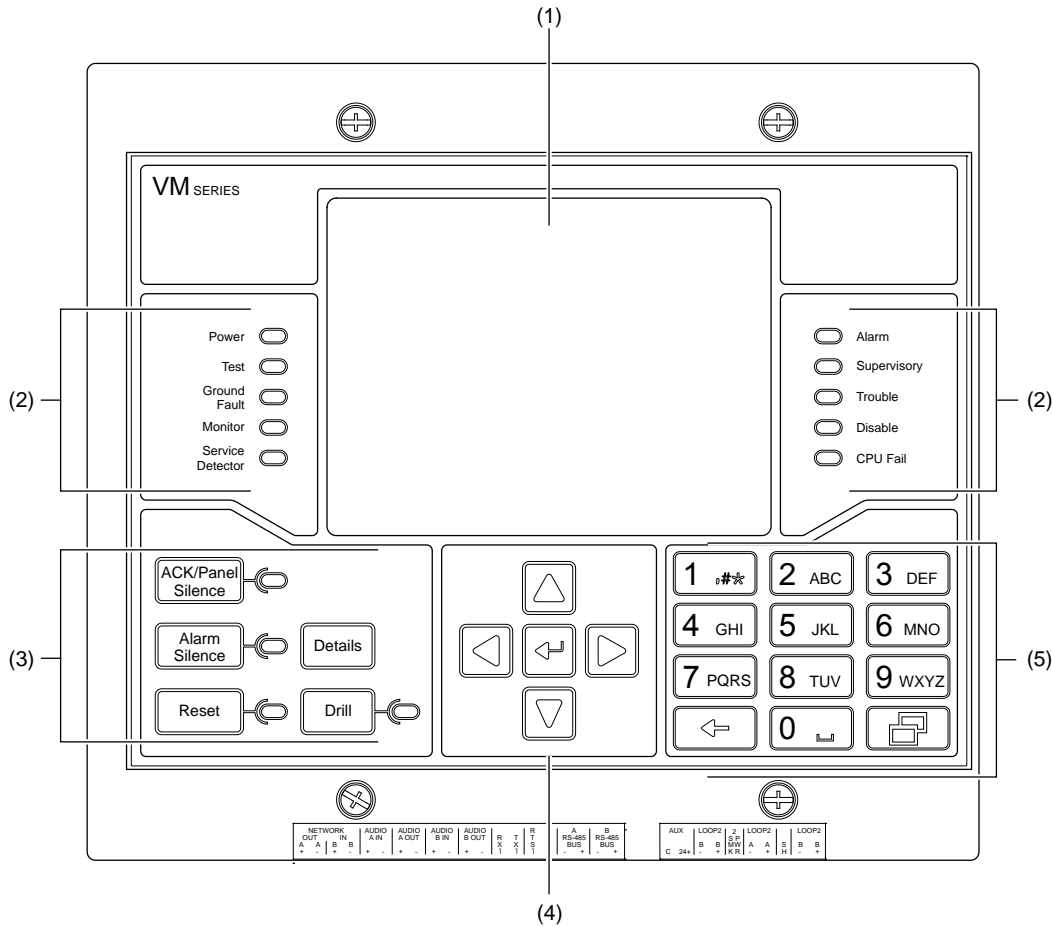

- (1) LCD screen  
 (2) System status indicators  
 (3) Common controls and indicators  
 (4) Cursor keypad  
 (5) Alphanumeric keypad

## Operator controls and indicators

Table 5: User interface operator controls

Control/Indicator	Description
LCD screen	Backlit liquid crystal display, 240 × 320 pixels, 24 lines of 40 characters. The LCD provides information relevant to the current condition of the control panel.
ACK/Panel Silence common control and LED [1]	Pressing the button acknowledges an active event. The control panel buzzer only silences after <i>all</i> events have been acknowledged. The LED indicates the panel is in an off-normal condition and that the panel has been placed in Panel Silence mode.
Alarm Silence common control and LED	Pressing the button turns off the emergency voice/alarm communications (EVAC) and Alert channels, and all active audible and visible notification appliance circuits. Pressing the button a second time turns the notification appliance circuits back on. The LED indicates that the active notification appliance circuits have been silence.  The Alarm Silence function can be configured to require an access level password.

Control/Indicator	Description
Reset common control and LED	<p>Pressing the button activates the system's reset sequence to restore the system to normal. The LED flashes quickly during the smoke power-down phase, flashes slowly during the power-up phase, is on steady during the system restore, and is off when the system has reset.</p> <p>The Reset function can be configured to require an access level password.</p>
Details common control	<p>Pressing the button displays additional information about the event highlighted on the LCD screen. The displayed information is described below.</p> <ul style="list-style-type: none"> <li>• For Zone groups, a list of active devices in the group</li> <li>• For Instruction Text groups, the entire instruction text</li> <li>• For maintenance alerts, a list of dirty devices</li> <li>• For common troubles, a list of specific troubles for a selected device</li> </ul>
Drill common control and LED	<p>Pressing the button activates the drill command function. The LED indicates while the drill is active. Pressing the button a second time stops the drill.</p> <p>The Drill function can be configured to require an access level password.</p>
Cursor keypad	<p>Pressing the cursor button scrolls through menus, event messages, and event queues. Pressing the Enter button enters the selection. See "Accessing and exiting menus and commands" on page 35.</p>
Alphanumeric keypad	<p>Pressing number buttons selects a menu item or enters the respective number into the system for use in conjunction with other system functions, such as addresses. Pressing the Backspace button takes you back to the previous screen and backspaces for address entries. Pressing the Menu button displays the command menus. See "Accessing and exiting menus and commands" on page 35.</p>

[1] The control panel buzzer can be configured to resound at a regular interval to remind the operator that the panel has been silenced.

## System status indicators

See Figure 4 on page 13 for the location of the system status indicators on the user interface.

**Table 6: User interface system status indicators**

Status indicator	Description
Power	The LED indicates the primary (AC) power status. The LED is on when the panel has primary power. The LED is off when the panel does not have primary power or when another panel in the network does not have primary power.
Test	The LED indicates that a part of the system is in test mode. A programmable timer automatically exits the test mode after a period of system inactivity.
Ground Fault	The LED indicates that a ground fault was detected in the system wiring.
Monitor	The LED flashes when there is an active monitor event on any loop and is steady once the event is acknowledged.
Service Detector	The LED indicates when a detector needs servicing.
Alarm	The LED serves as a common alarm event indicator. A flashing LED indicates that there is an event in the queue that has not been acknowledged. A steady LED indicates that all events in the queue have been acknowledged.

Status indicator	Description
Supervisory	The LED serves as a common supervisory event indicator. A flashing LED indicates that there is an event in the queue that has not been acknowledged. A steady LED indicates that all events in the queue have been acknowledged.
Trouble	The LED serves as a common trouble event indicator. A flashing LED indicates that there is an event in the queue that has not been acknowledged. A steady LED indicates that all events in the queue have been acknowledged.
Disable	The LED indicates when a device, card, group, time control, switch, or LED has been manually disabled.
CPU Fail	The LED indicates that the VM-CPU module has detected a processor failure. Processor failures must be reset manually.

## Buzzer indicator

In coordination with visual event notifications on the user interface, the control panel employs a buzzer to alert the operator of off-normal system conditions such as active alarms, active tests, disabled zones, active fault conditions, and active monitor conditions. The following list shows the buzzer patterns that sound with associated events.

- **Alarm:** 3-3-3 pattern
- **Supervisory:** 2-2 pattern
- **Trouble:** 30 pulses per minute
- **Monitor:** 3-3-3 pattern

**Note:** As determined by the VM-CU configuration, a reminder buzzer may sound.

## LCD screen indications

The LCD screen on the user interface provides information relevant to the current functional condition of the control panel. There are two screen modes: system normal and system off-normal.

### System normal LCD screen

System normal means that the life safety system is in its normal or startup state. In this state, the LCD screen is clear of any event messages. Only the time, date, custom banner (if programmed), and Alarm History are displayed. See Figure 5 on page 16.

**Figure 5: System normal LCD screen**

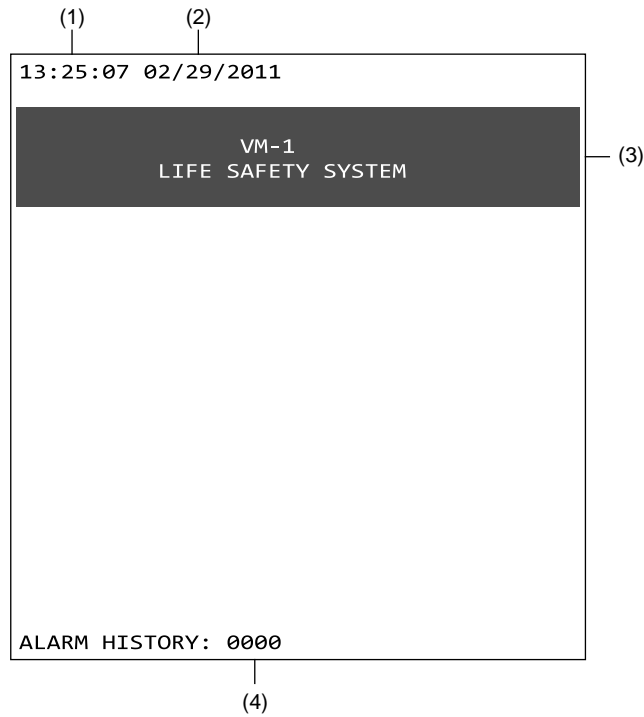

- (1) Time
- (2) Date
- (3) Custom banner message
- (4) Number of times the panel has gone into alarm

**System off-normal LCD screen**

System off-normal means the control panel has entered an alarm, disabled, or test state. In this state, event messages display on the screen that provide information about the events. Up to eight event messages can be displayed on the screen: seven in the event message section of the screen and one in the “Most Recent Event” section. See Figure 6 on page 17.

**Note:** The system off-normal LCD screen (event message screen) only displays when events are activated. It does not display when events are restored.

Figure 6: System off-normal LCD screen

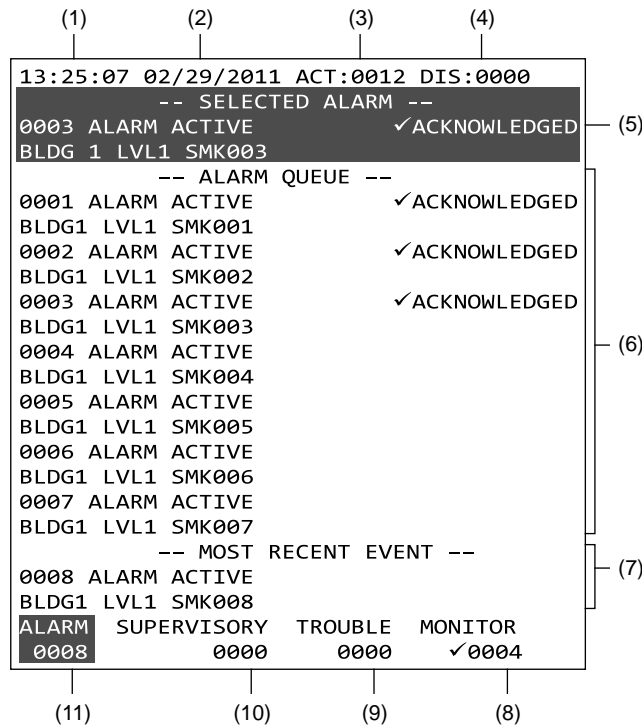

- |   |   |
|---|---|
| <p>(1) Time</p> <p>(2) Date</p> <p>(3) Number of active points</p> <p>(4) Number of disabled points</p> <p>(5) Selected event message</p> <p>(6) Event message field</p> <p>(7) Most recent, highest priority event message</p> | <p>(8) Number of monitor event messages stored in the Monitor Queue</p> <p>(9) Number of trouble event messages stored in the Trouble Queue</p> <p>(10) Number of supervisory event messages stored in the Supervisory Queue</p> <p>(11) Number of alarm event messages stored in the Alarm Queue</p> |
|---|---|

## Event message queues

The VM-1 control panel dynamically maintains 1,000 most recent, highest priority event messages across the four queues. An individual queue can hold 999 messages. The queues display at the bottom of the event message screen (see Figure 6 above).

The event message queues allow you to view details of messages to help locate points that are in an abnormal state. When the system signals a status change, the control panel posts the event message for the point that activated the event into the appropriate event message queue.

The four types of queues and event messages are listed below, by priority.

- **Alarm (highest priority):** Alarm event messages are used to identify the source of an active alarm within the system. They signal fire alarms or other life-threatening emergencies (e.g., active smoke detectors, pull stations, waterflow alarm switches).
- **Supervisory:** Supervisory event messages are used to identify changes to a supervisory state with the system. They can signal off-normal conditions with sprinkler and extinguishing systems, and other equipment related property safety (e.g., a closed gate valve).
- **Trouble:** Trouble event messages are used to identify faults with the alarm system. They can signal missing detectors, disabled points, and ground faults.

- Monitor (lowest priority): Monitor event messages are used to signal the operation of ancillary equipment (e.g., a fan feedback switch).

An event message consists of two lines of text, as shown in Figure 7. The first line displays the event number and the event name. The second line displays the message text, which is either the address of the point that activated the event or, if programmed, a location description.

**Figure 7: Event message**

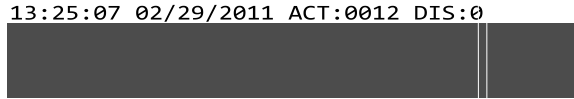

## User access levels

Certain user interface controls and command menu functions are password protected and have a user access level that is determined by the marketplace setting. The five user access levels are detailed in Table 7 below.

Each access level is given a default password that should be changed once the panel is put into service. See “Changing Access Level passwords” on page 50 for instructions.

**Note:** User access for initiating commands times out after a preconfigured period. When the time-out setting is reached, the panel reverts to the default level. The time-out period is configured in the VM-CU and can be set from 5 to 99:59 minutes. The default setting is 5 minutes.

**Table 7: User access level privileges**

User access level	Privileges
Default level (1) (No password required)	<ul style="list-style-type: none"> <li>• Acknowledge and panel silence function (ACK/Panel Silence button)</li> <li>• Alarm silence function (button) [1]</li> <li>• Reset function (button) [1]</li> <li>• Drill function (button) [1]</li> <li>• Details function (button)</li> <li>• Event details</li> <li>• Statuses</li> <li>• Reports</li> <li>• Output selection</li> <li>• Display/printer selection</li> <li>• Toggle language</li> </ul>

User access level	Privileges
Level 2	All default privileges, plus: <ul style="list-style-type: none"> <li>• Devices (enable/disable)</li> <li>• Zone groups (enable/disable)</li> <li>• Remote read lock (activate/restore)</li> <li>• Remote write unlock (activate/restore)</li> <li>• Gas accel response (activate/restore)</li> <li>• Sensor bypass (activate/restore)</li> <li>• Alternate sensitivity (activate)</li> <li>• Alternate message route (activate)</li> <li>• Primary sensitivity (restore)</li> <li>• Primary message route (restore)</li> <li>• Change time (program)</li> <li>• Change date (program)</li> </ul>
Level 3	All default and 2 privileges, plus: <ul style="list-style-type: none"> <li>• AND group (enable/disable)</li> <li>• Instruction Text group (enable/disable)</li> <li>• Time control (enable/disable)</li> <li>• Switch (enable/disable)</li> <li>• LED (enable/disable)</li> <li>• Relay (activate/restore)</li> <li>• Audio amp (activate/restore)</li> <li>• Audio message (activate/restore)</li> <li>• Holiday list (program)</li> <li>• Change password for level 2 (program)</li> </ul>
Level 4	All default, level 2, and 3 privileges, plus: <ul style="list-style-type: none"> <li>• Service group (enable/disable)</li> <li>• Card (enable/disable)</li> <li>• Restart by panel (program)</li> <li>• Restart all panels (program)</li> <li>• Clear history (program)</li> <li>• Test (start/cancel)</li> <li>• VM device test</li> <li>• Change password for level 3 (program)</li> </ul>

[1] Can be programmed from the VM-CU for an access level password

## Command menus

System commands are organized into menus that are used to operate the control panel from the LCD screen. The Main Menu is the gateway to all other command menus. For instructions on accessing menus and commands, see “Accessing and exiting menus and commands” on page 35.

### Main Menu

**Table 8: Main Menu selection descriptions**

Selection	Access level	Description
Status	None	Displays the Status Menu
Enable	None	Displays the Enable Menu
Disable	None	Displays the Disable Menu
Activate	None	Displays the Activate Menu
Restore	None	Displays the Restore Menu
Reports	None	Displays the Reports Menu
Program	None	Displays the Program Menu
Test	None	Displays the Test Menu

### Status Menu

Use the commands on the Status Menu to check the status of the system. The report that each command creates includes both physical points and pseudo points.

**Table 9: Status Menu selection descriptions**

Selection	Access level	Description
All Active Points	None	Displays or prints a list of all points that are in an active or other off-normal state (trouble, disable, etc.)
Alarm	None	Displays or prints a list of all active (in alarm) alarm input device types
Supervisory	None	Displays or prints a list of all active supervisory input device types
Trouble	None	Displays or prints a list of all points in trouble
Monitor	None	Displays or prints a list of all active monitor input device types
Test	None	Displays or prints a list of points in an active service group that are in the active or trouble state
Disabled Points	None	Displays or prints a list of all addressable points that are disabled
Outputs	None	Displays or prints a list of all active output device types and LED-switch card LEDs

## Enable Menu

All components are enabled at power-up unless programmed otherwise. Use the commands on the Enable Menu to place parts of the system that have been disabled back into service.

**Table 10: Enable Menu selection descriptions**

Selection	Access level	Description
Device	2	Enables a device or circuit; requires the panel, card, and device address
Card	4	Enables an option card or control-indicating module; requires the panel and card address
Group	Level 3: AND, Zone, and Inst. Text groups Level 4: Service Group	Displays the Enable Group Menu from which you can enable the following: <ul style="list-style-type: none"> <li>• AND Group: Select from a list of AND groups</li> <li>• Service Group: Select from a list of Service groups</li> <li>• Zone Group: Select from a list of Zone groups</li> <li>• Inst Text Group: Select from a list of Instruction Text groups</li> </ul>
Time Control	3	Displays a list of the programmed time controls from which a time control may be enabled.
Switch	3	Enables a switch on a control-indicating module; requires the panel, card, and device address
LED	3	Enables the LEDs on a control-indicating module; requires the panel, card, and device address

## Disable Menu

Use the commands on the Disable Menu to take individual zones, input and output points, option cards, and other parts of the fire alarm system out of service.

**Table 11: Disable Menu selection descriptions**

Selection	Access level	Description
Device	2	Disables a device or circuit; requires the panel, card, and device address
Card	4	Disables an option card or control-indicating module; requires the panel and card address
Group	Level 3: AND, Zone, and Inst. Text groups Level 4: Service Group	Displays the Disable Group Menu from which you can disable the following: <ul style="list-style-type: none"> <li>• AND Group: Select from a list of AND groups</li> <li>• Service Group: Select from a list of Service groups</li> <li>• Zone Group: Select from a list of Zone groups</li> <li>• Inst Text Group: Select from a list of Instruction Text groups</li> </ul>
Time Control	3	Displays a list of the programmed time controls, from which a time control may be disabled
Switch	3	Disables a switch on a control-indicating module; requires the panel, card, and device address
LED	3	Disables the LEDs on a control-indicating module; requires the panel, card, and device address

## Activate Menu

Use the commands on the Activate Menu to switch outputs and LED indicators on, and switch sensor sensitivity and event message routing to their alternate settings.

**Table 12: Activate Menu selection descriptions**

Selection	Access level	Description
Alt Sensitivity	2	Switches fire detector sensitivity settings from primary alarm sensitivity to alternate alarm sensitivity.
Alt Message Route	2	Switches event message routing from primary message routing to alternate message routing.
Relay	3	<p>Activates a relay or output module. Select one of the states from the Output Priority Menu. Requires a panel, card, and device address.</p> <ul style="list-style-type: none"> <li>• <b>Set:</b> Overrides low, medium, and high priority commands and forces the device to the desired state. The Set priority does not reset the device's priority counters.</li> <li>• <b>Latch:</b> Overrides low, medium, and high priority commands and forces the device to the desired state. The Latch priority does reset the device's priority counters.</li> <li>• <b>Low Priority:</b> Forces the device to the desired state and adjusts the Low Priority counter accordingly.</li> <li>• <b>Medium Priority:</b> Forces a device to the desired state and adjusts the Medium Priority counter accordingly.</li> <li>• <b>High Priority:</b> Forces a device to the desired state and adjusts the High Priority counter accordingly.</li> </ul>
LED	3	<p>Changes the output state of an LED from off to an active state or from one active state to another active state. Select one of the states from the Output Priority Menu. Requires a panel, card, and device address.</p> <ul style="list-style-type: none"> <li>• <b>Steady:</b> Select one of the states from the Output Priority Menu. <ul style="list-style-type: none"> <li>• <b>Set:</b> Overrides low, medium, and high priority commands and forces the device to the desired state. The Set priority does not reset the device's priority counters.</li> <li>• <b>Latch:</b> Overrides low, medium, and high priority commands and forces the device to the desired state. The Latch priority does reset the device's priority counters.</li> <li>• <b>Low Priority:</b> Forces the device to the desired state and adjusts the Low Priority counter accordingly.</li> <li>• <b>Medium Priority:</b> Forces a device to the desired state and adjusts the Medium Priority counter accordingly.</li> <li>• <b>High Priority:</b> Forces a device to the desired state and adjusts the High Priority counter accordingly.</li> </ul> </li> <li>• <b>Fast Blink:</b> Select one of the states from the Output Priority Menu (see the priority states described in "Steady"). <ul style="list-style-type: none"> <li>• Set</li> <li>• Latch</li> <li>• Low Priority</li> <li>• Medium Priority</li> <li>• High Priority</li> </ul> </li> </ul>

Selection	Access level	Description
		<ul style="list-style-type: none"> <li>• Slow Blink: Select one of the states from the Output Priority Menu (see the priority states described in “Steady” above)</li> <li>• Set</li> <li>• Latch</li> <li>• Low Priority</li> <li>• Medium Priority</li> <li>• High Priority</li> </ul>
Audio Amp [1]	3	<p>Changes the output state of an ACHS channel selector card. Select one of the states from the Output Priority Menu. Requires a panel, card, and device address.</p> <ul style="list-style-type: none"> <li>• Set: Overrides low, medium, and high priority instructions and forces the device to the desired state. The Set priority does not reset the device’s priority counters.</li> <li>• Latch: Overrides low, medium, and high priority instructions and forces the device to the desired state. The Latch priority does reset the device’s priority counters.</li> <li>• Low Priority: Forces the device to the desired state and adjusts the Low Priority counter accordingly.</li> <li>• Medium Priority: Forces a device to the desired state and adjusts the Medium Priority counter accordingly.</li> <li>• High Priority: Forces a device to the desired state and adjusts the High Priority counter accordingly.</li> </ul>
Audio Message [1]	3	<p>Allows selection of a different audio message and channel for a corresponding amplifier. Requires the message and channel for a panel, card, and device address.</p>
Sensor Bypass	2	<p>Keeps the photo element on a PHS Multisensor Smoke Detector from generating a supervisory message. Requires a panel, card, and device address).</p>
Gas Accel Response	2	<p>Accelerates the carbon monoxide (CO) rate of detection for a CO detector for testing purposes. Requires a panel, card, and device address.</p>
Remote Read Lock	2	<p>Use when connecting to the panel to read status and diagnostic information via TCP/IP instead of the RS-232 connection. By default, this feature is “unlocked.” Locking this feature prevents reading from the panel.</p> <p>The command can be issued to a single panel or all panels.</p> <p><b>Note:</b> Activating and restoring the Remote Read Lock command does not affect reading panel status and diagnostic information over the RS-232 connection.</p>

Selection	Access level	Description
Remote Write Unlock	2	<p>Allows a project database download to the control panel via a TCP/IP connection instead of an RS-232 connection when the panel is equipped with an Ethernet card. The default setting is “locked.”</p> <p>The command can be issued to a single panel or all panels.</p> <p><b>Notes</b></p> <ul style="list-style-type: none"> <li>Activating and restoring the Remote Write Unlock command does not affect downloading the project database over the RS-232 connection.</li> <li>This function should only be used by the installer or service provider. Changes to the fire alarm system must be tested and may require local authority approval.</li> </ul>

[1] Requires a VM-PMI Paging Microphone Interface

## Restore Menu

Use the commands on the Restore Menu to switch outputs and LED indicators off, and switch sensor sensitivity and event message routing to their primary settings.

**Table 13: Restore Menu selection descriptions**

Selection	Access level	Description
Primary Sensitivity	2	Returns the fire detector sensitivity setting from alternate to primary alarm sensitivity.
Primary Msg Route	2	Returns the fire detector sensitivity setting from alternate to primary message routing.
Relay	3	<p>Restores the output state of a relay. Select one of the states from the Output Priority Menu. Requires a panel, card, and device address.</p> <ul style="list-style-type: none"> <li>Set</li> <li>Latch</li> <li>Low Priority</li> <li>Medium Priority</li> <li>High Priority</li> </ul>
LED	3	<p>Restores the output state of an LED from on to an inactive state. Select one of the states from the Output Priority Menu. Requires a panel, card, and device address.</p> <ul style="list-style-type: none"> <li>Set</li> <li>Latch</li> <li>Low Priority</li> <li>Medium Priority</li> <li>High Priority</li> </ul>

Selection	Access level	Description
Audio Amp	3	Restores the output state of an ACHS channel selector card. Select one of the states from the Output Priority Menu. Requires a panel, card, and device address. <ul style="list-style-type: none"> <li>• Set</li> <li>• Latch</li> <li>• Low Priority</li> <li>• Medium Priority</li> <li>• High Priority</li> </ul>
Audio Message	3	Restores the message and channel for a corresponding amplifier. Requires the message and channel for a panel, card, and device address.
Sensor Bypass	2	Returns the photo element on a PHS Multisensor Smoke Detector to normal supervisory messaging. Requires a panel, card, and device address.
Gas Accel Response	2	Returns the CO rate of detection for a CO detector to normal. Requires a panel, card, and device address.
Remote Read Lock	2	Returns the panel to the unlocked state by either panel or all panels.
Remote Write Unlock	2	Returns the panel to the locked state by either panel or all panels.

## Reports Menu

Use the commands on the Reports Menu to retrieve maintenance and service related information from the control panel. There are four kinds of reports: Device Maintenance, History, Revisions, and DACT Compliance.

**Table 14: Reports Menu**

Selection	Access level	Description
Device Maintenance	None	Lets you select one of the reports described below. <ul style="list-style-type: none"> <li>• Dirty Devices &gt; 80%: Lists all addressable smoke detectors that have a %Dirty value of 80% and greater. Smoke detectors that are more than 80% dirty should be cleaned or replaced as soon as possible. Requires a panel address. You can display or print the report.</li> <li>• Dirty devices &gt; 20%: Lists all addressable smoke detectors that have a %Dirty value 20% and greater. A smoke detector that is more than 20% dirty should be noted for possible cleaning or replacing. Requires a panel address. You can display or print the report.</li> <li>• Single Device: Lists the %Dirty value for a single smoke detector. The report also includes the smoke detector's model type, primary and alternate alarm sensitivity values, and, if programmed, a location description. Requires a panel, card, and device address. You can display or print the report.</li> <li>• Devices on a card: Lists the %Dirty value for all of the smoke detectors on a loop. The report also includes each smoke detector's model type, primary and alternate alarm sensitivity values, and, if programmed, a location description. Requires a panel, card, and loop controller address. You can display or print the report.</li> </ul>

Selection	Access level	Description
History	None	<p>Creates a report that lists the last 1,000 events or operator instructions processed by the control panel. The items in the list are presented in reverse chronological order. The event or system command name, address, time and date of occurrence, and the source that initiated the event or command are included.</p> <p>Requires a panel address. You can display or print the report for the following:</p> <ul style="list-style-type: none"> <li>History with Text: Provides a history of events and operator commands logged by the panel. For each point that activated or restored, the detail includes the point's message text.</li> <li>History without Text: Provides a history of events and operator commands logged by the system. For each point that activated or restored, the detail includes the point's device address.</li> </ul>
Revisions	None	<p>Creates a report that lists the revision level of all the hardware and software components installed in the cabinet. Requires a panel address. You can display or print the report.</p>
DACT Compliance	None	<p>Creates a report of the installed VM-DACT address and its NFPA compliance. Requires a panel address. You can display or print the report.</p> <p><b>Note:</b> If “Fully Programmable” was selected in the VM-CU for the VM-DACT setting, the panel will report that it is noncompliant. However, individual correlations could have been written in the configuration utility that make it compliant.</p>

## Program Menu

Use the commands on the Program Menu to modify certain system settings, restart the system, and clear the alarm history. If the system was programmed with a secondary language, you can toggle languages from the Program Menu.

**Table 15: Program Menu selection descriptions**

Selection	Access level	Description
Change Time	2	Sets the system time set in hours, minutes and seconds (HHMMSS) that appears at the top of the LCD screen.
Change Date	2	Sets the system date in month, day, and year that appears at the top of the LCD screen.
Edit Password	Level 2 to change Level 1  Level 3 to change Level 2  Level 4 to change Level 3	Changes the password for Access levels 1 to 3.
Restart	4	Restarts the fire alarm system without removing power. The command can be made by panel or all panels.
Edit Holiday List	3	Creates a list of holidays so that a panel can activate a time-controlled event based on whether the day is a scheduled holiday. Each panel holds its own list up to 255 holidays.

Selection	Access level	Description
		<p>Select one of the following:</p> <ul style="list-style-type: none"> <li>• Add Holiday: Requires the month and day (MMDD)</li> <li>• Edit Holiday: Displays a list of scheduled holidays that can be edited</li> <li>• Delete Holiday: Displays a list of scheduled holidays that can be deleted</li> </ul>
Clear History	4	<p>Resets the alarm counter and erases the list of events that occurred on the panel since it was placed into service or the last time the history file was cleared.</p> <p>The command can be issued to a single panel or all panels.</p> <p><b>Caution:</b> This command is for use only by an authorized service technician. Clearing the panel history file means that all history data for the panel is permanently deleted.</p>
Toggle Language	None	<p>Switches the LCD menu names and default primary message text to a preprogrammed secondary language.</p> <p><b>Notes</b></p> <ul style="list-style-type: none"> <li>• The “Secondary Language” option must have been selected in the VM-CU for this function to work.</li> <li>• Custom message text does not switch to the secondary language when toggled.</li> </ul>

## Test Menu

Use the commands on the Test Menu to perform periodic inspection tests on the fire alarm system.

**Table 16: Test Menu selection descriptions**

Selection	Access level	Description
Start Test	4	Displays a list of service groups. You can verify the operation of devices in a selected group without causing the control panel to enter the fire alarm or trouble state.
Cancel Test	4	Displays a list of service groups. Upon canceling a test, any devices left in an active state causes the panel to report a trouble.
Lamp Test	None	Temporarily turns on the panel buzzer, LED indicators, and every LCD screen pixel.
VM Device Test	4	<p>Places a VM-1 device into test condition. VM-1 devices include all sensors and modules.</p> <p>Select one of the listed test conditions. Requires the panel, card, and device address.</p> <ul style="list-style-type: none"> <li>• Alarm [1]: Tests the primary active state of an input device.</li> <li>• Prealarm [2]: Tests the secondary active state of an input device.</li> <li>• Trouble</li> </ul>

[1] Alarm means the primary active state of an input device. For example, monitor or supervisory states can also be tested with this command.

[2] Prealarm means the secondary active state of an input device if it supports it. For example, some security devices have a secondary state. This command allows you to test it (Example: security tamper).



# Chapter 3

## Operating instructions

### Summary

This chapter provides instructions for operating the fire alarm system from the VM-1 control panel's user interface.

### Content

Operating states	31
Normal state	31
Alarm state	31
Disable state	31
Supervisory state	32
Trouble state	32
Monitor state	33
Test state	33
Drill state	34
Control panel power up	34
Initial power up	34
Utilizing the user interface keypads	35
Accessing and exiting menus and commands	35
Selecting event queues	36
Entering a panel, card, or device address	36
Selecting an event message	36
Silencing the panel buzzer	36
Silencing alarm signals	37
Acknowledging events	37
Resetting the fire alarm system	38
Restarting the fire alarm system	38
Clearing the alarm history	38
Viewing event message details	39
Device details	39
Group details	39
Instruction text details	39
Viewing reports	40
Status reports	40
Abnormal points report	40
Device maintenance reports	41
History report	41
System revisions report	42
DACT Compliance report	43
Disabling and enabling devices	43

- Disabling and enabling option cards 44
- Disabling and enabling logic groups 45
- Disabling and enabling system time controls 46
- Testing the system and devices 46
  - Performing a lamp test 46
  - Testing devices 46
  - Testing alarm input devices 47
- Changing output states 47
  - Changing the output state for a relay 48
  - Changing the output state for an audio amplifier 48
- Switching the smoke detector alarm sensitivity thresholds 49
  - Primary alarm sensitivity threshold 49
  - Alternate alarm sensitivity threshold 49
  - Alarm sensitivity settings 49
  - Switching the sensitivity threshold 49
- Changing event message routing 50
  - Changing the event message routing 50
- Changing Access Level passwords 50
- Changing the LCD screen language 51
- Downloading a database 51
  - Ethernet download 52
  - RS-232 download 53
- Using a TCP/IP connection to read from the panel 54
- Setting the system time and date 54
  - Setting the time 54
  - Setting the date 55
- Configuring holiday lists 55
- Control-indicating module 56
  - Disabling and enabling control-indicating module 56
  - Disabling and enabling control-indicating module elements 57
  - Changing the output state of an LED 57

# Operating states

The VM-1 control panel operates in the normal, alarm, disable, supervisory, trouble, monitor, test, and drill states.

## Normal state

The system operates in the normal (or quiet) state in the absence of any events. In the normal state, only the Power LED is on and the LCD screen shows the time, date, custom banner (if programmed), and the Alarm History count (see Figure 5 on page 16).

## Alarm state

The control panel enters the alarm state (system off-normal) when a point signals an alarm event. For example, a detector, manual pull station, or waterflow switch is activated.

### Output of the alarm state

Upon entering the alarm state, the control panel:

- Activates all common alarm outputs and common alarm relays
- Activates the common alarm contact on the main board
- Activates the first alarm pseudo point
- Changes the active state for the point that signaled the alarm event

### Indication of the alarm state

To indicate it is in the alarm state, the control panel:

- Sounds the panel buzzer
- Flashes the Alarm LED
- Displays an event message in the Alarm Queue for the point that signaled the alarm event

If the active point is an alarm zone and a control-indicating module is installed, the control panel also flashes the zone's alarm LED on the module.

## Disable state

The control panel enters the disable state when a point signals that a system component is disabled.

When a point is disabled, the control panel does not process any of the point's status changes and the point remains in its current state. For example, if an audible device type in the normal state was disabled and subsequently activated, the audible device type would not turn on until it was enabled. Conversely, if an active audible device type were disabled and subsequently restored, the audible device type would not turn off until it was enabled.

If a point in trouble is disabled and the cause of the trouble changes while the point is disabled, the point's original trouble event message may not update when the point is enabled.

**Note:** For anything other than a zone, use the Disabled Points command on the Status Menu to identify a disabled point.

### **Output of the disable state**

Upon entering the disable state, the control panel:

- Activates the first trouble pseudo point
- Activates the first disable pseudo point
- Changes the active state for the point that signaled the disable event

### **Indication of the disable state**

To indicate it is in the disable state, the control panel:

- Sounds the panel buzzer
- Turns on the Disable LED
- Flashes the Trouble LED
- Displays an event message in the Trouble Queue for the point that signaled the disable event, provided there are no higher priority events

## **Supervisory state**

The control panel enters the supervisory state when a point signals a supervisory event.

### **Output of the supervisory state**

Upon entering the supervisory state, the control panel:

- Activates the common supervisory contacts on the VM-CPU
- Activates the first supervisory pseudo point
- Changes the active state for the point that signaled the supervisory event

### **Indication of the supervisory state**

To indicate it is in the supervisory state, the control panel:

- Sounds the panel buzzer
- Flashes the Supervisory LED
- Displays an event message in the Supervisory Queue for the point that signaled the supervisory event, provided there are no higher priority events

If the active point is a supervisory zone and a control-indicating module is installed, the control panel also flashes the zone's active LED on the module.

## **Trouble state**

The control panel enters the trouble state when a point signals a trouble event.

### **Output of the trouble state**

Upon entering the trouble state, the control panel:

- Activates the common trouble contacts on the main board
- Activates the first trouble pseudo point
- Changes the active state for the point that signaled the trouble event

### Indication of the trouble state

To indicate it is in the trouble state, the control panel:

- Sounds the panel buzzer
- Flashes the Trouble LED
- Turns on the Ground Fault LED if the trouble is an earth ground fault

If the point is an alarm, supervisory, or monitor zone and a control-indicating module is installed, the control panel also flashes the zone's Trouble LED on the module.

## Monitor state

The control panel enters the monitor state when a supervisory or monitor input is activated.

### Output of the monitor state

Upon entering the monitor state, the control panel:

- Activates the first monitor pseudo point
- Changes the active state for the point that signaled the monitor event

### Indication of the monitor state

To indicate it is in the monitor state, the control panel:

- Sounds the panel buzzer
- Displays the point's event message in the Monitor Queue, provided there are no higher priority events

If the point is a monitor zone and a control-indicating module is installed, the control panel also flashes the zone's active LED on the module.

**Note:** Monitor indications are restored automatically when the monitor input is restored.

## Test state

The control panel enters the test state when a service group is activated.

### Output of the test state

Upon entering the test state, the control panel:

- Activates the first monitor pseudo point
- Activates the first trouble pseudo point
- Activates the first test pseudo point
- Changes the active state for the service group that was activated

While in the test state:

- When a member of an active service group signals an active event, the control panel executes the service group's active test response
- When a member of an active service group signals a trouble event, the control panel executes the service group's trouble test response

**Note:** If you do not program a trouble test response, the control panel executes the active test response instead.

### Indication of the test state

To indicate it is in the test state, the control panel:

- Sounds the panel buzzer
- Flashes the Trouble LED
- Displays an event message in the Trouble Queue for the first test pseudo point, provided there are no higher priority events
- Displays an event message in the Monitor Queue for the service group that was activated, provided there are no higher priority events

## Drill state

The drill function activates the system notification appliances generally for conducting a fire drill. In this state, an alarm is not transmitted to the central monitoring station.

### Output of the drill state

Upon entering the drill state, the control panel:

- Activates the first activated pseudo point
- Changes the active state for the device that activated

### Indication of the drill state

To indicate it is in the drill state, the control panel:

- Activates audible and common alarm output devices
- Activates configured visible devices

# Control panel power up

## Initial power up

When you power up the VM-1 control panel for the first time, the LCD may begin to show event messages on the screen as the VM-CPU microprocessor begins communicating with devices. You can use the ACK/Panel Silence button to silence the buzzer and acknowledge any events.

Once powered up, you need to download a database created in the VM-CU to the control panel. You can create a startup version of the database to assign panel addresses and perform preliminary device verifications. See “Creating an initial startup database” on page 76.

### Notes

- Before applying power to the control panel, make sure the standby batteries are not connected to the PS10-4B Power Supply.
- The PS10-4B Power Supply should already be installed and mains AC (primary power) wired to the input terminals (TB1). See the *PS10-4B Power Supply Board Installation Sheet* (P/N 3101774-EN) for other wiring instructions.
- For a network system, download the initial database to each control panel separately to establish the correct control panel addresses. After the initial download, all further downloads can be made from a single panel in the network.

- For networked systems, you should not connect the network wiring until after the project has been downloaded to each of the panels and you have cleared all troubles except for network communication faults.

#### To power up the control panel for the first time:

- Apply power to the control panel.
- Connect the batteries to the battery wiring terminal on the PS10-4B Power Supply. See “Standby batteries” on page 86.
- Press the ACK/Panel Silence button, if necessary.
- Download the database as instructed in “Downloading a database” on page 51.
- If errors display on the LCD screen, refer to “Runtime errors” on page 105 for information on resolving them.
- For a network system, clear any faults between control panels.
- Verify proper operation. Refer to “Routine maintenance and tests” on page 109 for Initial and Reacceptance testing.

## Utilizing the user interface keypads

Use the alphanumeric keypad and cursor keypad to access and exit the command menus, scroll through the menus and lists, select event messages, and enter menu selections and addresses.

**Figure 8: User interface keypads**

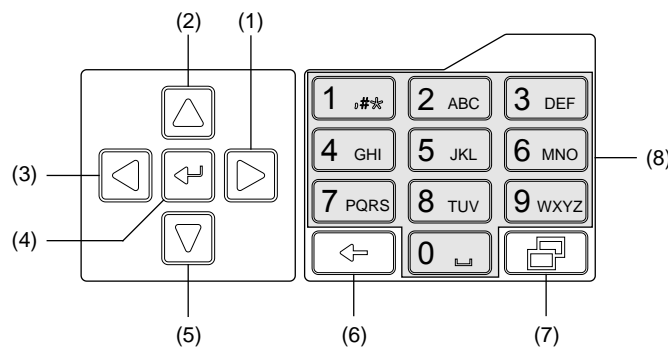

- |                  |                      |
|------------------|----------------------|
| (1) Right button | (5) Down button      |
| (2) Up button    | (6) Backspace button |
| (3) Left button  | (7) Menu button      |
| (4) Enter button | (8) Number buttons   |

## Accessing and exiting menus and commands

#### To access the menus and commands:

- Press the Menu button. See Figure 8 above.
- Press the Up or Down button to select the menu, and then press the Enter button.  
— or —
- Press the corresponding menu number on the alphanumeric keypad.

### To exit a menu or command:

1. Press the Menus button.

## Selecting event queues

1. Press the Left or Right button.

## Entering a panel, card, or device address

1. Press the desired number on the alphanumeric keypad when prompted for device or panel address.  
To reenter a number, press the Backspace button.
2. Press the Enter button on the cursor keypad.

## Selecting an event message

1. Press the Up or Down button to select an event message displayed on the LCD screen.  
The selected event appears in a highlighted field at the top of the screen, as shown in Figure 9.

**Figure 9: Selecting an event message**

```
13:25:07 02/29/2011 ACT:0012 DIS:0000
-- SELECTED ALARM --
0003 ALARM ACTIVE
BLDG 1 LVL1 SMK003
-- ALARM QUEUE --
0001 ALARM ACTIVE
BLDG1 LVL1 SMK001
0002 ALARM ACTIVE
BLDG1 LVL1 SMK002
```

## Silencing the panel buzzer

The VM-1 sounds the panel buzzer when an event message is posted into one of the event message queues. Pressing the ACK/Panel Silence button silences the panel buzzer only *after* all events have been acknowledged. The panel buzzer automatically re-sounds when a new event message is posted or when the panel trouble resound timer expires (typically 24 hours).

### Notes

- The panel buzzer may be configured to sound periodically to remind you of unacknowledged event messages.
- For nonlatching events, the panel buzzer automatically silences when the event is restored. For example, when a trouble clears.
- Pressing the ACK/Panel Silence button also silences the buzzer on remote annunciators, provided the remote annunciators are communicating.

**To silence the panel buzzer:**

1. Press the ACK/Panel Silence button.

All events must be acknowledged before the panel silences. If necessary, acknowledge events by using this same button.

## Silencing alarm signals

---

**WARNING:** Death or serious injury. The protected premises may be occupied. Do not silence alarm signals or reset the control panel unless you are authorized to do so and only after all occupants have been evacuated.

---

**Note:** The Alarm Silence button can be programmed in the VM-CU for access level 0 to 4.

Pressing the Alarm Silence button turns off all audible and common alarm device types, and if configured, visible device types.

Depending on the VM-CU configuration, the alarm silence operation:

- May be inhibited for 1 to 3 minutes after an alarm event
- May not turn off visible notification appliances
- May not silence notification appliances if water is flowing through the sprinkler system
- May automatically silence notification appliances after 1 to 60 minutes

Silenced outputs automatically re-sound when:

- The Alarm Silence button is pressed a second time
- Another alarm input device type is activated
- A subsequent device in an active zone is activated and the system is configured to allow zone re-sounding

**To silence alarm signals:**

1. Press the Alarm Silence button.
2. If prompted, enter the user access level password.

## Acknowledging events

It is important to acknowledge all activated events and review the reason for them. When an event occurs, the control panel displays an event message on the LCD screen, sounds the panel buzzer, places the event in the appropriate queue (Alarm, Supervisory, Trouble, or Monitor), and flashes the ACK/Panel Silence LED.

When an event is acknowledged, a check mark and the word “Acknowledged” are placed to the right of the event. If no other events need to be acknowledged the LED steadies, the panel silences, and a check mark is placed in the queue field at the bottom of the screen.

**To acknowledge an event:**

1. Press the ACK/Panel Silence button.

## Resetting the fire alarm system

---

**WARNING:** The protected premises may be occupied. Do not reset the fire alarm system until the proper authorities have determined that the threat of fire is no longer present.

---

Pressing the Reset button restores the system to normal, provided all latched inputs have been restored before the end of the reset cycle. If alarm signal initiating devices have not been restored before the end of the reset cycle:

- Active alarm signals will remain active
- Silenced alarm signals will remain silenced

### Notes

- Depending on the VM-CU configuration for Silence Inhibit, the reset operation may be inhibited for 1 to 3 minutes after an alarm event.
- The Reset button does not affect disabled points or manually overridden functions.
- The Reset function can be programmed for an access level password.

### To reset the fire alarm system:

1. Press the Reset button.
2. If prompted, enter the user access level password.

## Restarting the fire alarm system

Restarting the system reinitializes it without removing power.

### To restart the fire alarm system:

1. Access the Main Menu, and then select Program.
2. Select Restart.
3. Select By Panel and then enter the panel address.  
— or —  
Select All Panels.
4. Enter the access level password.

## Clearing the alarm history

---

**Caution:** This command is for use only by an authorized service technician. Clearing the panel history file means that all history data for the panel is permanently deleted.

---

The alarm history counter keeps track of how many times the control panel has entered the alarm condition. Clearing the history resets the counter shown on the LCD screen (see Figure 5 on page 16) and erases the list of events that occurred on the panel since it was placed into service or the last time the history file was cleared.

**To clear the alarm history:**

1. Access the Main Menu, and then select Program.
2. Select Clear History.
3. Select By Panel, and then enter the panel address.  
— or —  
Select All Panels.
4. Enter the access level password.

## Viewing event message details

Viewing event details provides the address of the device that generated the event and, if programmed, the location. Different detail information is displayed for device, group, and instruction text.

**To view the details of an event message:**

1. Press the Details button.

**Figure 10: Event message details for a device activation**

```

13:25:07 02/29/2011 ACT:0012 DIS:0000
-- SELECTED TROUBLE --
0006 COMMON TRBL ACT
SIGA 2 Smoke Detector
-- DETAILS --
P:01 C:03 D:0001
COMM FAULT ACTIVE

```

### Device details

If a device activation causes an event, the Details screen shows the active device's logical address and the off-normal state.

### Group details

If a group activation causes an event, the Details screen shows the state of the device, device address, and device message, which is usually the device location.

### Instruction text details

You can program the system to include detailed instructions for certain events. When specific devices go into alarm, the system generates a related monitor event. If you select the monitor event, then press Details, the instruction text is displayed.

## Viewing reports

System reports are used to check the current condition or history of the VM-1 life safety network. A report can be displayed on the LCD screen or printed to a local printer.

### Status reports

The status reports listed below are available to help you determine the current state of the system.

- All Active Points: Lists all addressable points that are in an active (alarm) state
- Alarm: Lists all active alarm input device types
- Supervisory: Lists all active supervisory input device types
- Trouble: Lists all points in trouble
- Monitor: Lists all active monitor input device types
- Test: Lists points in an active service group that are in the active or trouble state
- Disabled Points: Lists all addressable points that are disabled
- Outputs: Lists all active output device types and control-indicating module LEDs

#### To access a status report:

1. Access the Main Menu, and then select Status.
2. Select the desired report.
3. Enter the panel address.
4. Select Display and scroll through the report.  
— or —  
Select Print Locally.
5. When finished, exit the screen.

### Abnormal points report

Use the All Active Points command on the Status Menu to display or print a list that includes all points in the system that are not in their normal state.

**Note:** During normal operation, most points in the system are not active. Points whose normal state is active are included in the list.

#### To display or print a list of all abnormal points:

1. Access the Main Menu, and then select Status.
2. Select All Active Points.
3. Enter the panel address.
4. Select Display and scroll through the report.  
— or —  
Select Print Locally.
5. When finished, exit the screen.

## Device maintenance reports

A set of device maintenance reports are available to help you determine if any addressable smoke detector devices require maintenance. Each report gives you the option to display it on the LCD screen or print it to a local printer.

The reports show the %Dirty values of the devices. This value is an indication of a smoke detector's ability to compensate for dust and dirt buildup inside the chamber. Smoke detectors with higher %Dirty values are less able to compensate. The available reports are:

- **Dirty Devices > 80%:** Lists all addressable smoke detectors that have a %Dirty value of 80% or greater. Smoke detectors that are more than 80% dirty should be cleaned or replaced as soon as possible. To view this report you must know the panel address.
- **Dirty devices > 20%:** Lists all addressable smoke detectors that have a %Dirty value of 20% or greater. A smoke detector that is more than 20% dirty should be noted for possible cleaning or replacing. To view this report you must know the panel address.
- **Single Device:** Lists the %Dirty value for a single smoke detector. The report also includes the smoke detector's model type, primary and alternate alarm sensitivity values, and, if programmed, a location description. To view this report you must know the panel, card, and device address of the smoke detector.
- **Devices on a card:** Lists the %Dirty value for all of the smoke detectors on a loop. The report also includes each smoke detector's model type, primary and alternate alarm sensitivity values, and, if programmed, a location description. To view this report you must know the panel number, card number, and loop number of the signaling line circuit.

### To access a device maintenance report:

1. Access the Main Menu, and then select Reports.
2. Select Device Maintenance, and then select the desired report.
3. Enter the requested address.
4. Select Display and scroll through the report.  
— or —  
Select Print Locally.
5. When finished, exit the screen.

## History report

The history report lists the last 1,000 events or operator instructions processed by the control panel or since its history was cleared. The event or system command name, address, time and date of occurrence, and the source that initiated the event or command are included.

The report is structured with the most recent event or instruction listed first. The report can be displayed for viewing on the LCD screen or printed to a local printer. The history reports are listed below.

- **History with Text:** Provides a history of events and operator commands logged by the panel. For each point that activated or restored, the detail includes the point's message text.
- **History without Text:** Provides a history of events and operator commands logged by the system. For each point that activated or restored, the detail includes the point's device address.

### To view a history report:

1. Access the Main Menu, and then select Reports.
2. Select History.

3. Select the desired report and enter the panel address.
4. Select Display and scroll through the report.  
— or —  
Select Print Locally.
5. When finished, exit the screen.

## System revisions report

The Revisions report provides system database information, installed card types and their firmware, bootstrap, and database versions, and system IP addresses.

The initial Revision Report screen shows system information described in the table below.

**Table 17: System Revisions report**

Item	Description
Alarm Count	Shows the total number of times that the panel has gone into alarm since the alarm history was cleared
Market	Shows the Marketplace setting configured in the VM-CU
CPU	Shows the VM-CPU Main Board firmware version number
VM-CU	Shows the VM-CU version number
Audio DB	If a supplementary audio feature is installed, shows the database version number
CU PRJCT	Shows the VM-CU project (database) version
DB S/N	Shows the database serial number created when the database was converted <b>Note:</b> Database serial numbers must match to avoid database incompatibility faults
DB Date	Shows the date the database was downloaded
IP ADDR	Shows the IP address of the control panel
IP NETWRK	Shows the IP network address of the control panel
IP GTWY	Shows the IP gateway address of the control panel

Pressing the down arrow on the cursor keypad displays information on installed cards, as described in the table below.

**Table 18: Revision report for installed cards**

Item	Description
Card	Shows the card address
ANN Type	Shows the control-indicating module type
Card Type	Shows the card type
Firmware	Shows the card's firmware version and date
Bootstrap	Shows the VM-CPU card's bootstrap version and date
Database	Shows the card's database version and date

**To view the Revisions report:**

1. Access the Main Menu, and then select Reports.
2. Select Revisions.
3. Enter the panel address.
4. Select Display and view initial system information. Press the down arrow on the cursor keypad to view information on any installed cards.

— or —

Select Print Locally.

5. When finished, exit the screen.

**DACT Compliance report**

The VM-DACT module provides dialer communications between the VM-1 control panel and remote locations over telephone lines. During system programming, the VM-DACT can be automatically configured as an NFPA 72 compliant modem or manually customized (non-compliant). The DACT Compliance report lists the compliance level of VM-DACT modules in a given panel.

**Note:** If “Fully Programmable” was selected in the VM-CU for the VM-DACT setting, the panel will report that the module is noncompliant. However, individual correlations could have been written in the configuration utility that make it compliant. In this case, check the VM-CU or contact the installer to determine settings.

**To view the DACT Compliance report:**

1. Access the Main Menu, and then select Reports.
2. Select DACT Compliance, and then enter the panel address.
3. Select Display.

— or —

Select Print Locally.

4. When finished, exit the screen.

**Disabling and enabling devices**

Devices include input and output circuits, detectors, and modules. Disabling a device isolates it from the system. While the device is disabled, the VM-1 logs the status change signals but is prevented from processing the signals from the device until the device is enabled. For example, the VM-1 does not activate an alarm event when you activate a disabled detector, but it will after the detector is enabled.

The VM-1 keeps track of how many times you disable a device without enabling it. You must enable a device the same number of times you disable it in order to return the device to its original condition.

Device addresses are listed in Appendix B “Addresses” on page 189.

**Notes**

- You cannot disable a device configured as a common alarm output.
- Disabling all of the devices in a zone group automatically disables the zone group. Enabling each device in a zone group automatically enables the zone group.

- Disabling the device address for the dialer or a dialer account deletes all event messages sent to that account before they are transmitted. The dialer still transmits the account's test-abnormal message and any message that was in the dialer queue before the account was disabled.
- When you enable a device, all indicators and outputs activated by the device will reactivate.

**To disable a device:**

1. Access the Main Menu, and then click Disable.
2. Click Device, and then enter the panel, card, and device address.
3. Enter the access level password.

**To enable a device:**

1. Access the Main Menu, and then click Enable.
2. Click Device, and then enter the panel, card, and device address.
3. Enter the access level password.

## Disabling and enabling option cards

Option cards can include hardware layer cards and modules, and operator layer control-display modules. Disabling a card isolates it from the system. While the card is disabled, the VM-1 logs the status change signals but is prevented from processing the signals until the card is enabled.

The VM-1 keeps track of how many times you disable a card without enabling it. You must enable a card the same number of times you disable it in order to return the card to its original condition.

Option card addresses are listed in Appendix B "Addresses" on page 189.

**Note:** Disabling an Ethernet card may affect IP services. Table 19 below shows the IP services and how they are affected.

**Table 19: Effect on IP services when an Ethernet card is disabled**

IP services disabled	IP services not disabled
IP dialer service	SDU communications
Email service	PING
	DHCP server communications
	DNS server communications
	ECP FireWorks communications

**To disable an option card:**

1. Access the Main Menu, and then click Disable.
2. Click Card, and then enter the panel and card addresses.
3. Enter the access level password.

**To enable an option card:**

1. Access the Main Menu, and then click Enable.
2. Click Card, and then enter the panel and card addresses.
3. Enter the access level password.

## Disabling and enabling logic groups

A logic group is an *object* that is created in the VM-CU. Groups are required in order to execute certain system functions, but groups bear no physical relationship to the system. For example, smoke detectors can be assigned to the same zone group even though they are not attached to the same wire run.

Disabling a group isolates it from the system. While the card is disabled, the VM-1 logs the status change signals but is prevented from processing the signals until the card is enabled. For example in a zone group, the control panel does not activate an alarm event when you activate a disabled detector, but it will after the detector is enabled.

The VM-1 keeps track of how many times you disable a group without enabling it. You must enable a group the same number of times you disable it in order to return the group to its pre-disabled condition.

**Note:** If you disabled a zone group by disabling all of the devices in the zone, enabling the zone enables all of the devices in the zone.

The logic groups are listed below.

- **AND group:** A collection of devices that are grouped in the database to provide a group response that is separate from that of its member devices. An AND group activates when a specified number of devices change to a specified state. The specified state can be alarm, supervisory, trouble, monitor, or not active (NA). AND groups can be configured to signal an alarm, supervisory, trouble, or monitor condition upon activation.
- **Service group:** A collection of devices that are grouped together in the database to provide a unique response for testing purposes. When enabled, the Service group automatically disables the member device's normal alarm response, and provides a common alternate test response.
- **Zone group:** A collection of input devices that are grouped in the database order to provide a unique response separate from their individual device responses. Zone groups can be configured to go into alarm when any member of the group goes active or when any device in the group goes into trouble.
- **Instruction text group:** A collection of devices that are grouped in the database to provide additional detailed instructions or warnings when any device in the group changes to a qualified active state.

**To disable a group:**

1. Access the Main Menu, and then select Disable.
2. Select Group, and then select the group type.
3. Select the group from the group list.
4. Enter the access level password.

**To enable a group:**

1. Access the Main Menu, and then select Enable.
2. Select Group, and then select the group type.
3. Select the group from the group list.
4. Enter the access level password.

## Disabling and enabling system time controls

System time controls are configured in the VM-CU to set up automatic starting and stopping of system events based on time and date. The controls run in the background and do not require any operator action. In the event you need to disable a control, you can do so from the control panel.

### To disable a time control:

1. Access the Main Menu, and then select Disable.
2. Select Time Control, and then select the desired time control.
3. Enter the access level password.

### To enable a time control:

1. Access the Main Menu, and then select Enable.
2. Select Time Control, and then select the desired time control.
3. Enter the access level password.

## Testing the system and devices

Test commands are used to perform periodic inspection tests on the fire alarm system.

### Performing a lamp test

Use the Lamp Test command on the Test Menu to verify the operation of the LCD screen and LED indicators. The lamp test command temporarily turns on the panel buzzer, all LED indicators, and every pixel on the LCD. The lamp test command only operates the indicators on the panel from which the command is initiated.

### To perform a lamp test:

1. Access the Main Menu, and then select Test.
2. Select Lamp Test.

### Testing devices

The VM Device Test command allows you to place a V-Series device into the alarm, prealarm, or trouble condition for testing purposes. V-Series devices include all detectors and modules. To test a device, it must be connected to a signaling line circuit.

### Notes

- For latching devices, you must reset the panel to restore the tested device to its normal state. Nonlatching devices restore automatically without resetting the panel.
- The Alarm Test command puts the device into alarm condition and activates its programmed alarm responses.

**To test a VM device:**

1. Access the Main Menu, and then select Test.
2. Select VM Device Test, and then select the test condition.
3. Enter the panel, card, and device addresses.
4. Enter the access level password.

**Testing alarm input devices**

In order to test an alarm input device, the device must be part of a Service group that was created in the VM-CU. Service groups allow alarm input devices to be activated without placing the system into alarm. The protected premises may be divided into more than one Service group to make testing possible without leaving the entire premises unprotected. See the VM-CU help for instructions on creating Service groups.

**Notes**

- Putting a Service group into test introduces a Service Group Active event in the Trouble Queue. To determine which Service group is in test, view the details of the event message (see “Viewing event message details” on page 39).
- The alarm input test automatically times out after approximately 1-hour of inactivity.

**To put a Service group into test:**

1. Access the Main Menu, and then select Test.
2. Select Start Test, and then select the desired Service group.
3. Enter the access level password.

**To cancel the alarm input device test:**

1. Access the Main Menu, and then select Test.
2. Select Cancel Test, and then select the Service group that is in test.
3. Enter the access level password.

**Changing output states**

Use the Activate and Restore commands to change the output state of relays, NAC circuit outputs, control-indicating module LEDs, and audio amplifiers. Changing the output state requires entering a command priority level to one of the following output states.

- **Set:** Overrides low, medium, and high priority instructions and forces the device to the desired state. The set priority does not reset the device’s priority counters.
- **Latch:** Overrides low, medium and high priority instructions and forces the device to the desired state. The latch priority will reset the device’s priority counters.
- **Low Priority:** Forces the device to the desired state and adjusts the low priority counter accordingly.
- **Medium Priority:** Forces a device to the desired state and adjusts the medium priority counter accordingly.
- **High Priority:** Forces a device to the desired state and adjusts the high priority counter accordingly.

For control-indicating module, see “Changing the output state of an LED” on page 57.

## Changing the output state for a relay

A relay module can be on (activated) or off (restored). In the active state, the relay module's normally-open contacts are held closed and the normally-closed contacts are held open.

### To activate a relay output state:

1. Access the Main Menu, and then select Activate.
2. Select Relay, and then select the desired output priority.
3. Enter the panel, card, and device address of the relay.
4. Enter the access level password.

### To restore a relay output state:

1. Access the Main Menu, and then select Restore.
2. Select Relay, and then select the desired output priority.
3. Enter the panel, card, and device address of the relay.
4. Enter the access level password.

## Changing the output state for an audio amplifier

### To activate an audio amplifier output state:

1. Access the Main Menu, and then select Activate.
2. Select Audio Amp, and then select the desired output priority.
3. Enter the panel, card, and device address of the audio channel on the ACHS channel selector card (for example the EVAC channel).
4. Enter the access level password.
5. Return to the Activate Menu, and then select Relay.
6. Select the desired output priority.
7. Enter the panel, card, and device address of the amplifier card.

### To restore an audio amplifier output state:

1. Access the Main Menu, and then select Restore.
2. Select Audio Amp, and then select the desired output priority.
3. Enter the panel, card, and device address of the audio channel on the ACHS channel selector card.
4. Enter the access level password.
5. Return to the Restore Menu, and then select Relay.
6. Select the desired output priority.
7. Enter the panel, card, and device address of the amplifier card.

# Switching the smoke detector alarm sensitivity thresholds

Intelligent addressable smoke detectors are configured with two alarm sensitivity thresholds: primary and alternate. The alarm sensitivity setting, configured in the VM-CU, sets the threshold at which the smoke detector activates an alarm event. This allows you to increase or reduce an individual detector's sensitivity at various times of the day, dependent upon, environmental conditions, occupancy, manufacturing processes, etc.

A time control is commonly used to automatically switch alarm sensitivity thresholds. However, you can manually switch alarm sensitivity thresholds by using command menus.

## Primary alarm sensitivity threshold

Typically, the primary alarm sensitivity threshold is set to a lower threshold. This threshold is commonly used for a daytime operation to reduce the occurrence of nuisance alarms when a facility is occupied, or when environmental conditions may create prealarm conditions.

## Alternate alarm sensitivity threshold

The alternate alarm sensitivity threshold sets the *secondary threshold* at which the smoke detector activates an alarm event. Typically, the alternate threshold is set to a higher sensitivity threshold. This threshold is commonly used for a nighttime or weekend operation, when the facility is unoccupied.

## Alarm sensitivity settings

Alarm sensitivity settings are expressed in percent of smoke obscuration per foot. The setting defines the threshold at which the detector will change to the alarm state when the smoke in its sensing chamber exceeds the obscuration per foot threshold.

The alarm sensitivity setting can be set to one of five sensitivity levels.

- **Most:** Activates an alarm event when the smoke level reaches approximately 1.0 %/ft obscuration (0.7 %/ft for ionization detectors)
- **More:** Activates an alarm event when the smoke level reaches approximately 2.0 %/ft obscuration (1.0 %/ft for ionization detectors)
- **Normal:** Activates an alarm event when the smoke level reaches approximately 2.5 %/ft obscuration (1.2 %/ft for ionization detectors)
- **Less:** Activates an alarm event when the smoke level reaches approximately 3.0 %/ft obscuration (1.4 %/ft for ionization detectors)
- **Least:** Activates an alarm event when the smoke level reaches approximately 3.5 %/ft obscuration (1.6 %/ft for ionization detectors, 2.46 %/ft for a SIGA-SD Duct Smoke Detector)

**Note:** When smoke detectors having both ionization and photoelectric elements are used, the sensitivity setting applies to both elements.

## Switching the sensitivity threshold

**To activate the alternate alarm sensitivity settings:**

1. Access the Main Menu, and then select Activate.
2. Select Alt Sensitivity.
3. Enter the access level password.

**To restore the primary alarm sensitivity settings:**

1. Access the Main Menu, and then select Restore.
2. Select Primary Sensitivity.
3. Enter the access level password.

## Changing event message routing

Event messages are configured with two message routes: primary and alternate. Typically, the primary message route is used for a daytime operation and the alternate message route is used for a nighttime or weekend operation.

A time control is commonly used to automatically switch between event message routes. However, you can manually switch event message routes using the command menus.

### Changing the event message routing

**To activate alternate message routing:**

1. Access the Main Menu, and then select Activate.
2. Select Alt Message Route.
3. Enter the access level password.

**To restore primary message routing:**

1. Access the Main Menu, and then select Restore.
2. Select Primary Msg Route.
3. Enter your access level password.

## Changing Access Level passwords

Password protection is used to regulate access to certain user interface controls and commands. It is recommended that you change the default passwords once the panel is put into service.

Access level	Default password
1	1111
2	2222
3	3333
4	4444

**Note:** The user access time-out can be configured in the VM-CU. The default setting is 5 minutes. When user access times out, the panel returns to the default level (0).

An access level password can only be changed by a higher access level. This is referred to as the *controlling* access level. The access level you want to change is called the *target* access level.

**To change the access level password:**

1. On the Main Menu, choose Program.
2. On the Program Menu, choose Edit Password.
3. Click the target access level.
4. Enter the password for the controlling access level.
5. Enter the new password for the target access level.

## Changing the LCD screen language

Use the Toggle Language command on the Program Menu to switch the LCD menu names and default primary message text to a preprogrammed secondary language.

**Notes**

- The “Secondary Language” option must have been selected in the VM-CU for this function to work.
- Custom message text does not switch to the secondary language when toggled.

**To change LCD screen text attributes to the secondary language:**

1. Access the Main Menu, and then select Program.
2. Select Toggle Language.

## Downloading a database

The control panel provides three ways to download the VM-CU database into the VM-CPU directly from a computer.

- Through the RJ-45 Ethernet jack on the main board (requires optional Ethernet adapter card)
- Through the RS-232 RJ-11 modular jack on the main board
- Through the RS-232 terminal block on the main board (requires a separately ordered DB-9 programming cable P/N 260097)

**Note:** This function should only be used by the installer or service provider. Changes to the fire alarm system must be tested and may require local authority approval.

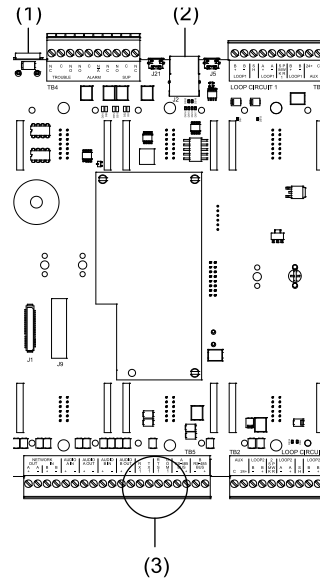
**Figure 11: Download-connectors on the VM-CPU**

(1) RJ-11 modular jack

(2) RJ-45 Ethernet cable jack

(3) RS-232 terminal block

## Ethernet download

For downloading the project database via a TCP/IP Ethernet connection, the VM-CPU is locked by default to disallow unauthorized database changes. Use the Remote Write Unlock command on the Activate Menu to allow the download.

### Notes

- An VM-ETH Ethernet adapter card must be installed on the VM-CPU and identified in the VM-CU to download the database using a TCP/IP Ethernet connection.
- Activating and restoring the Remote Write Unlock command does not affect downloading the project database over the RS-232 connection.
- A “Remote Write Unlocked” event appears in the Monitor Queue and the buzzer sounds when the panel is unlocked. Both are restored to normal after the panel is restored to its default setting.
- The unlock command times out after 15 minutes.

### To download the project database using an Ethernet connection:

1. Connect one end of an RJ-45 Ethernet patch cable, Cat 5e or better to the RJ-45 jack on the VM-CPU. See Figure 11 on page 52.
2. Connect the other end of the cable to the RJ-45 jack on the computer with the project database.
3. From the VM-1 control panel, access the Main Menu, and then click Activate.
4. Click Remote Write Unlock.
5. Click By Panel, and then enter the panel address and access level password.

— or —

Click All Panels, and then enter the access level password.

- From the VM-CU on the connected computer, configure the communication functions for a TCP/IP connection, and then download the database.

Press F1 to open the VM-CU Help topics, if necessary.

- When the download is finished, access the Main Menu, and then click Restore.
- Click Remote Write Unlock.
- Repeat step 3. If the user time-out period has expired, reenter the access level password.

## RS-232 download

### To download the project database using the RS-232 modular telephone jack:

- Connect one end of a standard RS-232 cable to the RJ-11 modular telephone jack on the VM-CPU. See Figure 12 on page 53.
- Connect the other end of the cable to the RS-232 jack on the computer with the project database.
- From the VM-CU on the connected computer, configure the communication functions, and then download the database.

Press F1 to open the VM-CU Help topics, if necessary.

### To download the project database using the RS-232 terminal block:

**Note:** Requires a separately ordered programming cable, P/N 260097.

- Connect one end of a DB-9 programming cable to the terminal block on the VM-CPU. See Figure 12.
- Connect the other end of the cable to the RS-232 jack on the computer with the project database.
- From the VM-CU on the connected computer, configure the communication functions for an RS-232 connection, and then download the database.

Press F1 to open the VM-CU Help topics, if necessary.

**Figure 12: RS-232 terminal block connections to the DB-9 programming cable**

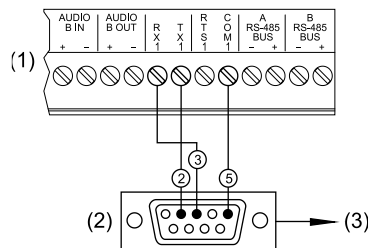

- VM-CPU terminal connector block
- Rear view of female DB-9 connector
- To the RS-232 jack of computer

## Using a TCP/IP connection to read from the panel

Use the Remote Read Lock command on the Activate Menu to be able to read status and diagnostic information from the panel instead of using the RS-232 connection. By default, the control panel is unlocked. See Figure 11 on page 52 for the location of the RJ-45 Ethernet connector on the VM-CPU main board.

### Notes

- An VM-ETH Ethernet card must be installed on the VM-CPU and identified in the VM-CU, and the panel connected to a LAN or WAN for data uploads from the panel.
- Activating and restoring the Remote Read Lock command does not affect reading panel status and diagnostic information over the RS-232 connection.
- A “Remote Read Locked” event appears in the Monitor Queue and the buzzer sounds when the panel is locked. Both are restored to normal after the panel is restored to its default setting.

### To prevent reading from the panel:

1. From the Main Menu, choose Activate.
2. Choose Remote Read Lock.
3. Choose By Panel, and then enter the panel address (PP).  
— or —  
Choose All Panels.
4. Enter the access level password.

### To allow reading from the panel:

1. From the Main Menu, choose Restore.
2. Choose Remote Read Lock.
3. Choose By panel, and then enter the panel address (PP).  
— or —  
Choose All Panels.
4. Enter the access level password.

## Setting the system time and date

The control panel incorporates a system clock to time stamp events and to activate time controls. The time is presented in 24-hour format. The date is presented in day-month-year format.

### Setting the time

Use the Change Time command on the Program Menu to set the system clock for the current time. The time is entered in 24-hour format, for example:

000000 = midnight  
010000 = 1:00 a.m.  
120000 = noon  
130000 = 1:00 p.m.  
235900 = 11:59 p.m.

**Note:** On NFPA 72 systems, the Change Time command is not available at access level 2.

**To set the system clock for the current time:**

1. Access the Main Menu, and then select Status.
2. Select Program, and then enter the access level password.
3. Enter the hour, minutes, and seconds. **Example:** To set the time for 7:27:00 p.m., enter 192700.

## Setting the date

Use the Change Date command on the Program Menu to set the system clock for the current date.

**Note:** On NFPA 72 systems, the Change Date command is not available at access level 2.

**To set the system calendar for the current date:**

1. Access the Main Menu, and then select Status.
2. Select Program, and then enter the access level password.
3. Enter the day (DD), month (MM) and year (YYYY).

## Configuring holiday lists

The Holiday time control is a special time control used to program holidays on a per panel basis. Holiday time controls supersede the normal VM-CU programmed system time controls on dates that are designated as holidays. The command is accessed from the Program Menu.

**To add a holiday:**

1. Access the Main Menu, and then select Program.
2. Select Edit Holiday List, and then select Add Holiday.
3. Enter the holiday month and day.
4. Enter the access level password.

**To edit a holiday:**

1. Access the Main Menu, and then select Program.
2. Select Edit Holiday List, and then select Edit Holiday.
3. Select the desired holiday, and then enter the correct month and day.
4. Enter the access level password.

**To delete a holiday:**

1. Access the Main Menu, and then select Program.
2. Select Edit Holiday List, and then select Delete Holiday.
3. Select the desired holiday.
4. Enter the access level password.

## Control-indicating module

The D12LS-VM Control-Indicating Module provides additional operator interface capability. Up to three modules can be mounted on any of the last three card address spaces on the electronics chassis. A blank insert is provided for labeling the LEDs and switches. The module consists of 12 groups of two LED-switches. The top LED can be configured in the VM-CU to amber, red, blue, or green. The bottom LED is amber.

**Figure 13: D12LS-VM Control-Indicating module**

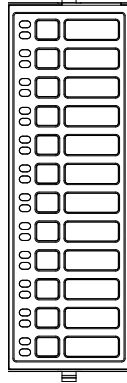

The buttons on the control-indicating module use one of three available operating modes that are database configured.

- **Toggle:** The state of the button changes each time the button is pushed (i.e. “off” to “on” or “on” to “off”). Toggle buttons are commonly used to control two-state operations such as on/off, open/close, speaker select, telephone select, etc.
- **Interlocked:** Three adjacent toggle buttons that operate as a group. Pushing any button in the group turns the output of the other two buttons “off” and turns its own output “on.” The interlocked mode is commonly used for hands-off auto control of HVAC systems. An interlocked button in the “on” state can be turned “off” without activating a second button by pressing the “on” button a second time. The output of the “on” button remains on, during panel reset. It must be manually returned to “Auto” when no longer required.
- **Momentary:** The button is “on” only while pressed by the operator. Momentary buttons are typically to issue brief commands. Example uses for momentary buttons include a lamp test, function reset, and test sequence. The command is issued only while the button is pressed.

You may find multiple button modes on a single control-indicating module. Consult your site-specific documentation for additional information.

### Disabling and enabling control-indicating module

Disabling a control-indicating module isolates it from the system. While disabled, changes to the module’s state are not processed. When the module is disabled, the Disable LED on the user interface indicates and a Disabled Active event shows in the Trouble Queue.

Enabling a control-indicating module re-establishes it as part of the system. When enabled, any changes in state that occurred while the module was disabled are processed.

#### To disable a control-indicating module:

1. Access the Main Menu, and then select Disable.
2. Select Card, and then enter the panel and card addresses.
3. Enter the access level password.

**To enable a control-indicating module:**

1. Access the Main Menu, and then select Enable.
2. Select Card, and then enter the panel and card addresses.
3. Enter the access level password.

**Disabling and enabling control-indicating module elements****Disabling and enabling control-indicating module switches****To disable a control-indicating module switch:**

1. Access the Main Menu, and then select Disable.
2. Select Switch, and then enter the panel, card, and device addresses.
3. Enter the access level password.

**To enable a control-indicating module switch:**

1. Access the Main Menu, and then select Enable.
2. Select Switch, and then enter the panel, card, and device addresses.
3. Enter the access level password.

**Disabling and enabling control-indicating module LEDs****To disable a control-indicating module LED:**

1. Access the Main Menu, and then select Disable.
2. Select LED, and then enter the panel, card, and device addresses.
3. Enter the access level password.

**To enable a control-indicating module LED:**

1. Access the Main Menu, and then select Enable.
2. Select LED, and then enter the panel, card, and device addresses.
3. Enter the access level password.

**Changing the output state of an LED**

Use the Activate command to change the output state of steady, fast blink, and slow blink LEDs on a control-indicating module. Changing the output state requires entering a command priority level to one of the following output states:

- **Set:** Overrides low, medium, and high priority instructions and forces the device to the desired state. The set priority does not reset the device's priority counters.
- **Latch:** Overrides low, medium, and high priority instructions and forces the device to the desired state. The latch priority does reset the device's priority counters.
- **Low Priority:** Forces the device to the desired state and adjusts the low priority counter accordingly.
- **Medium Priority:** Forces a device to the desired state and adjusts the medium priority counter accordingly.
- **High Priority:** Forces a device to the desired state and adjusts the high priority counter accordingly.

**To change the LED output state:**

1. Access the Main Menu, and then select Activate.
2. Select LED, and then select the desired indication rate.
3. Select the desired output priority.
4. Enter the panel, card, and device address of the relay.
5. Enter the access level password.

**To restore the LED output state:**

1. Access the Main Menu, and then select Restore.
2. Select LED, and then select the desired indication rate.
3. Select the desired output priority.
4. Enter the panel, card, and device address of the relay.
5. Enter the access level password.

# Chapter 4

## Supplementary applications

### Summary

This chapter describes supplementary applications that can be controlled or monitored locally to expand your life safety system capabilities.

### Content

- Digital audio subsystem 60
  - Network audio riser source 62
  - Digital audio riser source 63
  - Audio signal priority 63
  - Firefighter phone 66
  - Testing the audio system integrity 66
  - Using the paging microphone 67
  - Using the firefighters telephone 67
- Remote annunciation 67
  - LCD model remote annunciator controls and indicators 69
- FireWorks communication 72
- IP dialer and email communication 72
  - Ethernet wiring for IP dialer and email communication 72
  - Configuring IP services 73

## Digital audio subsystem

The digital audio subsystem consists of a variety of signal sources, integral amplifiers, and control software. The VM-PMI Paging Microphone Interface adds controls for emergency voice and alarm communications to the VM-1 life safety system. An optional VM-MFK Firefighter Telephone Kit can be installed on the VM-PMI to add two-way firefighter telephone capability to the paging microphone capability.

The audio subsystem is designed so that when an alert is issued through the paging interface, the page signal automatically overrides any other signals. Zoned amplifiers are distributed throughout the system and provide the demultiplexing, switching, amplification, and circuit supervision.

The VM-PMI is shown in Figure 12 and its components described in Table 20 below. See the *VM-PMI Paging Microphone Interface Installation Sheet* (P/N 3101788-EN) for technical specifications.

The VM-PMI with the VM-MFK Firefighter Telephone is shown in Figure 15 on page 61 and its components described in Table 21 on page 61. See the *VM-MFK Master Firefighter Telephone Kit Installation Sheet* (P/N 3101790-EN) for technical specifications.

A separately ordered VM-PMI-LK Language Kit is available that allows you to affix a language overlay on top of the English paging microphone and firefighter telephone interface, to change the interface control and indicator labels. See the *VM-PMI-LK Language Kit Installation Sheet* (P/N 3101996-EN) for a list of available kits and installation instructions.

**Figure 14: VM-PMI Paging Microphone Interface**

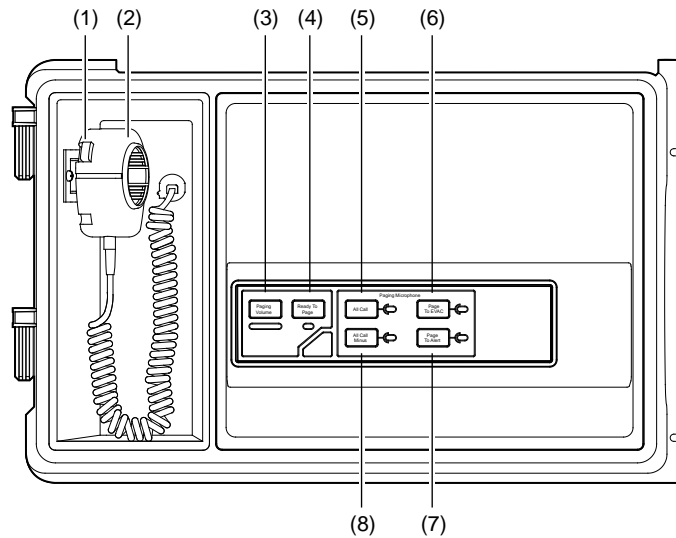
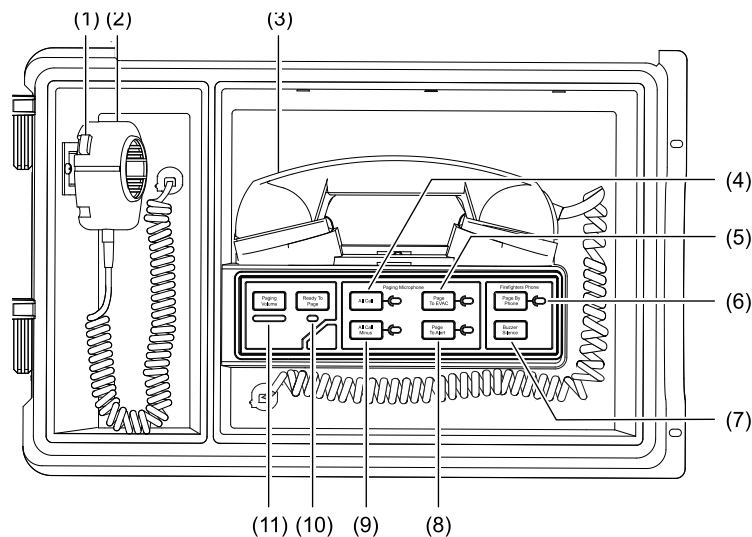

**Table 20: VM-PMI operator controls and indicator descriptions**

Item	Control/Indicator	Description
1	Push-to-talk (PTT)	Pressing the PTT button enables transmission of a live voice announcement.
2	Paging microphone	Handheld microphone that allows initiation of a live voice announcement.
3	Paging Volume	LED indicates the audio level of the person speaking into the microphone.
4	Ready To Page	LED flashes during preannouncement tone and is steady when ready to page.

Item	Control/Indicator	Description
5	All Call	Pressing the All Call button temporarily transfers all amplifiers to the Page channel while the page is active. The All Call command distributes the page signal to every amplifier in the system. Pressing the button a second time exits the All Call mode. The LED indicates when in the All Call mode.
6	Page To Evac	Pressing the Page To EVAC button temporarily transfers the Page signal to all amplifiers actively connected to the EVAC channel. All EVAC amplifiers then receive and distribute the Page signal. Pressing the button a second time exits the Page To EVAC mode. The LED indicates when in the Page To EVAC mode.  <b>Note:</b> The evacuation signal must be repeated for a period of not less than 3 minutes.
7	Page To Alert	Pressing the Page To Alert button temporarily transfers the Page signal to all amplifiers actively connected to the Alert channel. All Alert amplifiers then receive and distribute the page signal. Pressing the button a second time exits the Page To Alert mode. The LED indicates when in the Page To Alert mode.
8	All Call Minus	Pressing the All Call Minus button temporarily transfers the page signal to all amplifiers except those connected to the EVAC and Alert channels. Pressing the button a second time exits the All Call Minus mode. The LED indicates when in the All Call Minus mode.

**Figure 15: VM-PMI with VM-MFK Firefighters Telephone**



**Table 21: VM-PMI with VM-MFK operator controls and indicator descriptions**

Item	Control/Indicator	Description
1	Push-to-talk (PTT)	Pressing the PTT button enables transmission of a live voice announcement.
2	Paging microphone	Handheld microphone that allows initiation of a live voice announcement.

Item	Control/Indicator	Description
3	Telephone handset	Handset used to communicate with dedicated firefighter telephone stations that are strategically located throughout the facility.
4	All Call	Pressing the All Call button temporarily transfers all amplifiers to the Page channel while the page is active. The All Call command distributes the page signal to every amplifier in the system. Pressing the button a second time exits the All Call mode. The LED indicates when in the All Call mode.
5	Page To Evac	Pressing the Page To Evac button temporarily transfers the Page signal to all amplifiers actively connected to the EVAC channel. All EVAC amplifiers then receive and distribute the Page signal. Pressing the button a second time exits the Page to Evac mode. The LED indicates when in the Page to Evac mode.  <b>Note:</b> The evacuation signal must be repeated for a period of not less than 3 minutes.
6	Page by Phone	Pressing the Page by Phone button allows you to use the paging function using the telephone handset instead of the paging microphone.
7	Buzzer Silence	Pressing the Buzzer Silence button silences the phone call-in buzzer.
8	Page To Alert	Pressing the Page To Alert button temporarily transfers the Page signal to all amplifiers actively connected to the Alert channel. All Alert amplifiers then receive and distribute the page signal. Pressing the button a second time exits the Page To Alert mode. The LED indicates when in the Page To Alert mode.
9	All Call Minus	Pressing the All Call Minus button temporarily transfers the page signal to all amplifiers except those connected to the EVAC and Alert channels. Pressing the button a second time exits the All Call Minus mode. The LED indicates when in the All Call Minus mode.
10	Ready To Page	LED flashes during preannouncement tone and is steady when ready to page.
11	Paging Volume	LED indicates the audio level of the person speaking into the microphone.

## Network audio riser source

The EAEC Emergency Audio Evacuation Controller Card is the source of the network audio riser. Available audio sources are local and remote voice page functions. An integral tone generator database is provided for EVAC, Alert and other functions. Alternately, the EAEC integral digital voice message playback unit can simultaneously provide multiple prerecorded messages that may be assigned to any channel.

The network audio riser consists of a single pair (Class B) or two pairs (Class A / Class X) of wires connect all amplifiers together. The multiplexer within the EAEC converts and compresses the real time audio signal and converts it to a digital format. The output of the digital message playback unit and the integral tone generator database is already in the digital format. The signal sources in digital format are then combined together as selected by the system designer using a multiplexer. All command and control signals for the audio system are distributed over the network data riser.

## Digital audio riser source

The control panel supports up to three ACHS Audio Channel Selector cards that convert digital audio from an EAEC card into an analog preamp signal. The audio riser consists of a single pair (Class B) or two pairs (Class A) of wires that connect together all SIGA-AA30/50 amplifiers housed in a separate cabinet.

## Audio signal priority

During system configuration, each of the four available audio channels is assigned one of the four available types listed in Table 22. The Page and Auxiliary types may only be assigned to a single channel.

**Table 22: Network audio channel types and priorities**

Channel attribute	Priority
Page	1
EVAC	2
Alert	3
Auxiliary	4

Each channel type has a priority level associated with it. When more than one channel is commanded to source a given amplifier, the amplifier will connect to the source having the highest priority.

### Paging channel

Paging is a manual function. An operator is required to select a destination for the page, and then make an announcement. The Page channel is never automatically selected by the VM-1 system.

The page channel always carries a live page signal, regardless of its source. There are three sources that can supply the paging signal: the local paging microphone, the firefighter telephone, and the remote microphone. These sources are automatically prioritized as shown in Table 23.

**Table 23: Page priorities**

Priority	Page signal source
1 (highest)	Local microphone
2	Firefighter telephone
3 (lowest)	Remote microphone

The page command is a non-latching function. When the page command ends, amplifiers automatically switch back to the source channel that was active (if any) prior to the page command.

### VM-PMI special page modes

There are five types of page commands available on the network:

- All Call
- EVAC
- Alert
- All Call Minus
- Selective Page

The first four modes are available by pressing a single button on the front of the VM-PMI. These are the paging functions most commonly used in an emergency situation.

The page buttons provide instantaneous switching of the page signal to the most frequently contacted areas of the building. The special page modes do *not* require any source switching by zoned audio amplifiers. When a page switch is activated, the signal content of the four outgoing audio channels is modified. Figure 16 on page 65 illustrates this principle.

In the normal page mode, the audio signal sources are each connected to a separate audio channel, as represented by a v at the intersection of the signal source and the audio channel, shown at the lower left of Figure 16. Each audio channel is represented as a vertical line in this figure. The four audio channels are actually multiplexed together and distributed over a common pair of wires called the network audio riser. The figure shows the system in the normal page mode, with the zoned audio amplifiers processing an EVAC signal on the first floor, a page signal on the second floor, and an Alert signal on the third floor.

The Selective Page is issued by pressing a display-indicator button that is assigned to selected audio zones. The action temporarily transfers the selected amplifiers to the page channel while the page is active, distributing the page signal only to selected audio zones.

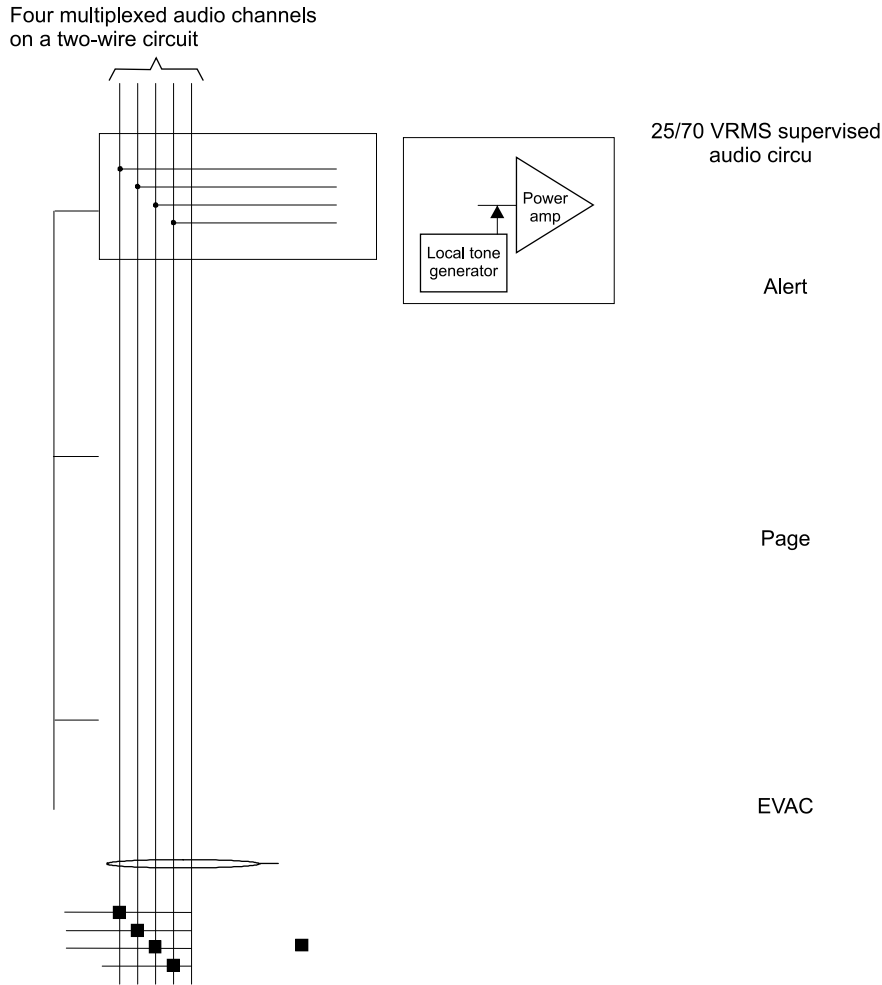
**Figure 16: Special page mode signal flow**

### Automatic messaging

One of the features of the VM-PMI is the method used to monitor the integrity of the digital audio system. When an audio messaging system is configured, default audio messages are recorded for the EVAC and Alert channels. The text of default messages should be generic in nature, and should not include location specific instructions. When the system is in the normal condition, the VM-PMI continuously transmits default messages over the network audio riser. The zone amplifiers use the default messages to verify their operational integrity, as well as the integrity of the riser wiring.

When an alarm is detected, the evacuation and alert message channels are selected by the amplifiers in the appropriate areas in the facility, as directed by the system correlations. If a specific evacuation message has been programmed to play in response to the alarm, it is sent out over the evacuation channel. Location specific evacuation messages contain information and instructions that should only be used for a specific alarm location.

Should a second alarm from another location be received, the evacuation message playing as a result of the first alarm may not be appropriate for the second alarm.

**Note:** In the event of conflicting messaging instructions caused by multiple alarm events, the system will play the default evacuation message whenever two or more different messages are requested at the same time on the evacuation channel. By reverting back to the generic default evacuation message in multiple alarm location scenarios, no one can be misdirected by the wrong message. Default messages also play during alarms when no location specific message has been requested.

## Firefighter phone

The VM-MFK contains a master telephone handset that provides an analog telephone riser for totally independent two-way communications between the fire command station and firefighter telephone stations/jack telephones installed at strategic locations throughout the protected facility.

Taking a telephone off-hook or plugging it into a telephone jack generates a visual and audible incoming call signal at the fire command station. The individual originating the call hears a tone until the handset is connected to the system. The fire command station operator manually connects the incoming phone call to the phone riser to complete the call. The operator can also use the telephone circuit as a page source, permitting paging via the telephone system.

See the *VM-MFK Master Firefighter Telephone Kit Installation Sheet* (P/N 3101790-EN) for wiring and technical specifications.

### Five phone off-hook limit

The circuitry on the VM-MFK Firefighter Telephone controller card can support up to five telephones off-hook in addition to the master handset at the VM-PMI at any one time. The flexibility of the VM-1 system permits any number of phones to be wired on a single phone circuit, as long as they are not all used simultaneously. There are a number of different designs that can be used to insure that no more than five phones are active at any one time.

### One phone per circuit

The advantages of installing a single firefighter phone station or jack on a GSA-CC1 module (personality code 6) are numerous. The system provides complete control and annunciation phone/circuit. Installing a single phone on a circuit permits the operator to immediately identify the exact location of the calling party. Because the VM-MFK will only permit five circuits to be connected simultaneously, the maximum number of off-hook handsets can never be exceeded. Should a branch telephone circuit be damaged during a fire, the fault will not affect other phone circuits. When there is only one phone per circuit, troubleshooting of faults is simplified.

## Testing the audio system integrity

Activate prerecorded audio messages stored in the VM-PMI to test the integrity of the digital audio system.

### To test the audio system integrity:

1. Access the Main Menu, and then select Activate.
2. Select Audio Message, and then enter the panel, card, device, and channel addresses.
3. Enter your access level password.
4. When finished, access the Main Menu, and then select Restore.
5. Select Audio Message, and then enter the panel, card, device, and channel addresses.
6. If required, enter your access level password.

## Using the paging microphone

The basic tasks in responding to an emergency event are:

1. Use the All Call button to announce the arrival of the fire department, making any necessary announcements.
2. Use the Page To Evac button to reinforce the evacuation of the occupants in areas receiving the evacuation signal.
3. Use the Page To Alert button to notify the areas not in immediate danger to prepare to evacuate, or that evacuating people may enter their safe area.
4. Use the All Call Minus button to make announcements to areas of the facility not receiving the EVAC or Alert signals, as required. Stairwells are typical areas to use the All Call Minus page function.

**Note:** If the site is equipped with a remote paging microphone, it may be used to issue pages throughout the facility. A remote microphone page is automatically overridden by any pages issued by the local microphone in the VM-PMI.

### To make an announcement using the local paging microphone:

1. Select the areas to receive the page by pressing the appropriate page function button(s). The button's integral LED will be on steady when the system is ready to receive the page.
2. Press the PTT button on the microphone. The Ready to Page LED will flash while the preannouncement tone is sounding.
3. Begin the announcement once the Ready to Page LED is on steady. Adjust your voice level so that the Paging Volume LED only flickers occasionally.
4. When you are finished making your announcement, release the PTT button, and then press the page function button again to cancel the page and return the system to its original condition.

**Note:** The system automatically cancels the page and returns to its original condition after a short delay, if you do not cancel the page manually.

## Using the firefighters telephone

The VM-MFK Master Firefighters telephone provides two-way communication between firefighters in the building and the Fire Command Center. You can also use the telephone handset as the paging microphone.

### To answer an incoming call:

1. Pick up the telephone handset.
2. Press the Buzzer Silence button.
3. Press the destination button. For example, "Floor 1 Phone."

## Remote annunciation

R-Series and K-R-Series remote annunciators communicate with the VM-1 control panel over the RS-485 riser. They provide common control switches, system status indicators, zone event messages, and zone status indicators at remote locations throughout the protected premises. The VM-1 life safety system compatible R-Series and K-R-Series remote annunciator models are shown in Figure 17 on page 68 and described in Table 24. See the *R-Series Remote Annunciators and Expanders Installation and Operation Guide* (P/N 3100969-EN) or *K-R-Series Remote Annunciators and Expanders Installation and Operation Guide* (P/N 3102382-EN) for specifications.

Operating power can come from one of the following sources:

- The auxiliary power outputs on a PS10-4B power supply card
- Continuous AUX power on the CPU
- An auxiliary/booster power supply that is UL/ULC listed for fire protective signaling systems

**Figure 17: Compatible R-Series / K-R-Series remote annunciators**

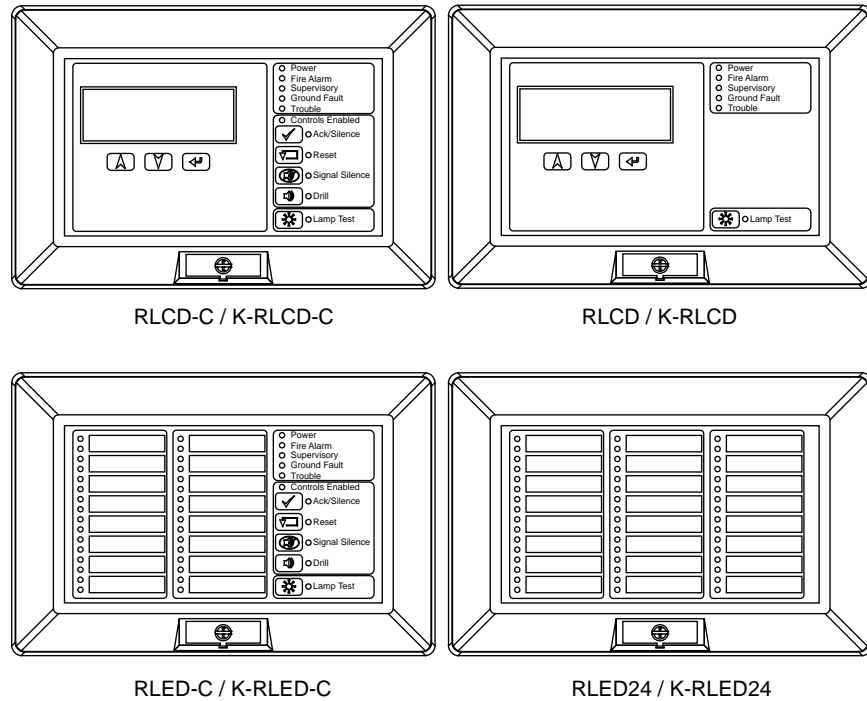
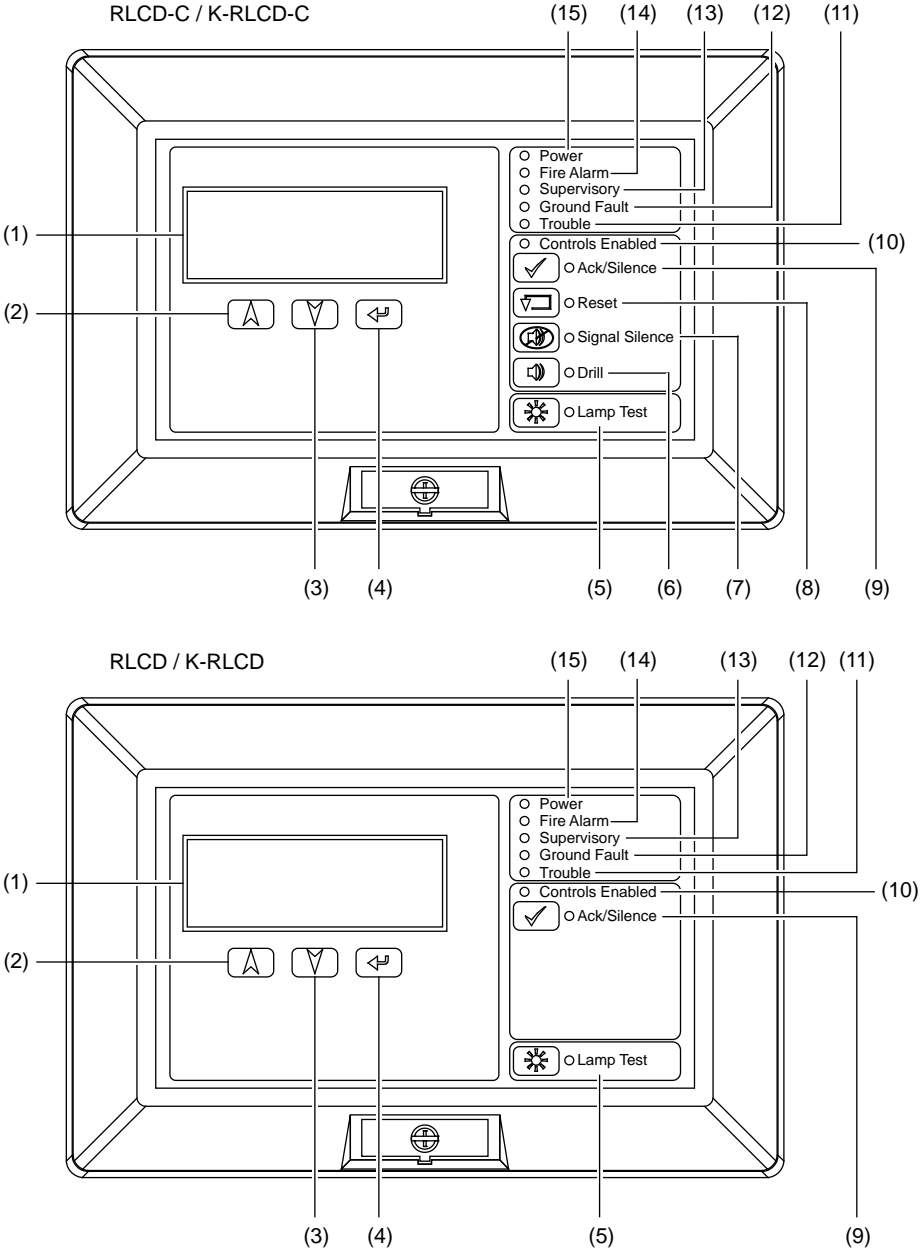

**Table 24: Compatible R-Series and K-R-Series remote annunciators**

Model	Description
RLCD-C / K-RLCD-C	Remote LCD text annunciator with common controls and indicators.
RLCD / K-RLCD	Remote LCD text annunciator with indicators (no common controls).
RLED-C / K-RLED-C	Remote LED annunciator with common controls and 16 pairs of programmable LEDs. The first 12 pairs are dedicated red-over-yellow LEDs. The last four pairs can be configured in the VM-CU as red-over-yellow LEDs or as yellow-over-yellow LEDs.
RLED24 / K-RLED24	Remote annunciator LED expander with 24 pairs of programmable LEDs. The top 12 pairs are dedicated red-over-yellow LEDs. The bottom 12 pairs can be configured in the VM-CU as red-over-yellow LEDs or as yellow-over-yellow LEDs.

# LCD model remote annunciator controls and indicators

Figure 18: LCD model remote annunciator controls and indicators



Note: Items 6 through 8 are excluded from the RLCD / K-RLCD.

Table 25: LCD model remote annunciator indicators and controls

Item	Item	Description
1	LCD screen	Displays system status, event messages, and event message details.
2	Up button	Pressing the button scrolls up through the messages in the event message queue and scrolls up through characters for password entry.

Item	Item	Description
3	Down button	Pressing the button scrolls down through the messages in the event message queue and scrolls down through characters for password entry.
4	Enter button	Pressing the button displays message details for the current message and enters the password character selected.
5	Lamp Test LED and button	Pressing the button turns on all LEDs and displays a test pattern on the LCD. The test runs for ten seconds. The LED indicates the lamp test is running.
6	Drill LED and button [1]	Pressing the button turns on all audible and common alarm output devices and, if configured, all visible devices. Pressing the button again turns them off. The LED indicates the function is active. Requires a password to operate.
7	Signal Silence LED and button [1]	Pressing the button turns off (silences) all active audible and common alarm output devices and, if configured, all visible devices. Pressing the button again turns them back on. The LED indicates the function is active. Requires a password or the enable controls key to operate.
8	Reset LED and button [1]	Pressing the button restores the system to the normal state, provided that no inputs are latched in the active state. The LED indicates the reset function is active. Requires a password or the enable controls key to operate.
9	ACK/Silence LED and button	Pressing the button silences the panel buzzer and acknowledges all current events. The LED indicates the function is active. Requires a password or the enable controls key to operate.
10	Controls Enabled LED	Blue LED indicates the controls in that group are enabled at the annunciator. Enabling the controls requires a password or the enable controls key.
11	Trouble LED	Yellow LED indicates an active trouble state (flashing = new trouble event, steady = all current trouble events have been acknowledged).
12	Ground Fault LED	Yellow LED indicates a ground fault somewhere in the system.
13	Supervisory LED	Yellow LED indicates an active supervisory state (flashing = new supervisory event, steady = all current supervisory events have been acknowledged).
14	Fire Alarm LED	Red LED indicates an active fire alarm state (flashing = new fire alarm event, steady = all current fire alarm events have been acknowledged).
15	Power LED	Green LED indicates the annunciator is energized.

[1] Control and indicator is not on the RLCD or K-RLCD remote annunciator.

LED model remote annunciator and expander controls and indicators

Figure 19: LED model remote annunciator and expander controls and indicators

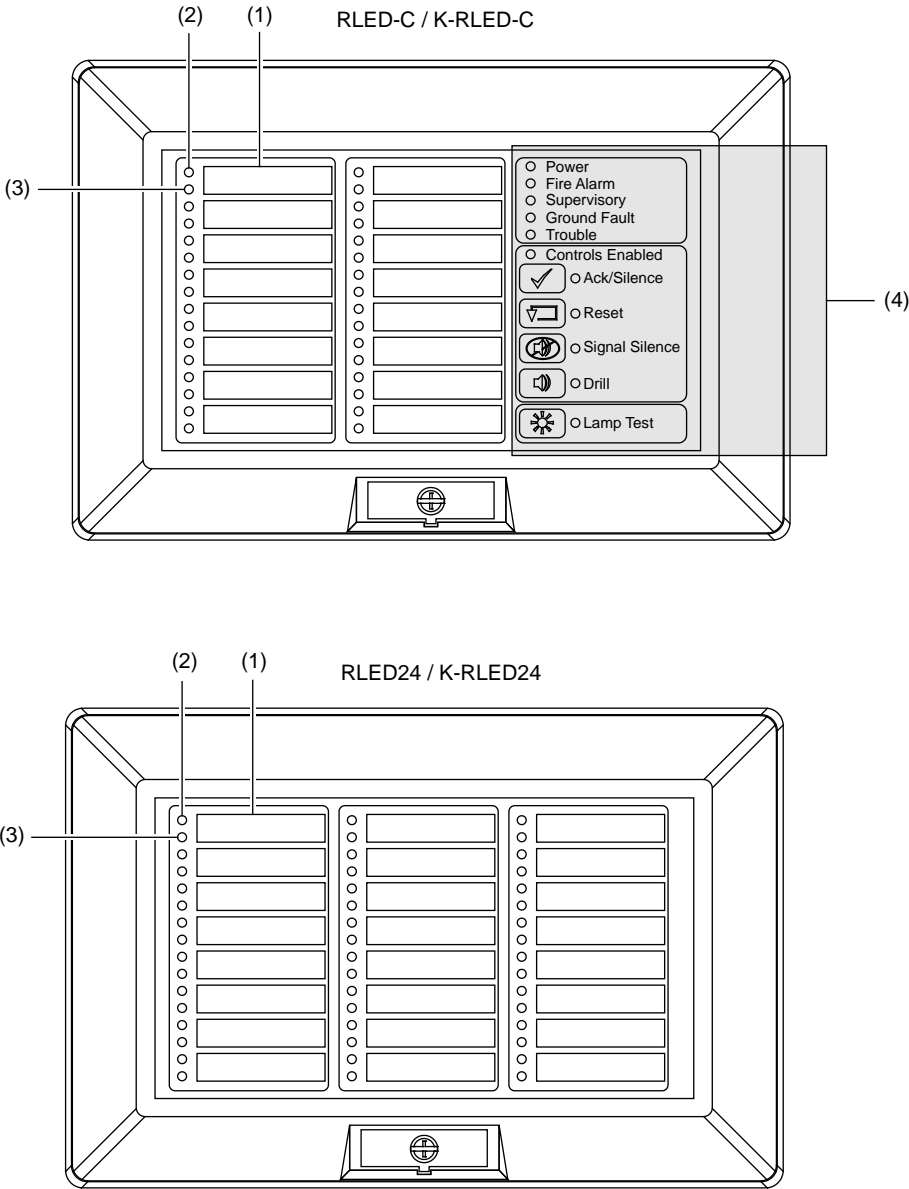

Note: Item 4 is excluded from the LED24 / K-RLED24.

Table 26: LED model remote annunciator and expander controls and indicators

Item	Item	Description
1	Zone description label	User-defined zone or device description
2	Active LED	Red LED indicates the zone or device is in alarm state
3	Trouble LED	Yellow LED indicates the zone or device is in trouble state
4	Controls and indicators [1]	See items 5 through 15 in Table 25 on page 69

[1] Controls and indicators are not on the RLED24 or K-RLED24 remote expander.

## FireWorks communication

FireWorks lets you use computers to monitor several networks of multiplex signaling systems.

For a VM-1 system to communicate over an RJ-45 connection, the following requirements must be met:

- The system must be running VM-CU version 1.30 or later
- A VM-ETH Ethernet adapter card must be installed
- Communication must be with a computer that supports IP connections and is running FireWorks (V8.1 or later)

The communication path uses an External Command Protocol (ECP) service for transmission of system events over IP to the computer for monitoring. Refer to the FireWorks documentation for your system for wiring details. Refer to the VM-CU Help for instructions on configuring the IP communication settings.

## IP dialer and email communication

For VM-1 systems using VM-CU version 1.30 or later, network events can be transmitted through any VM-1 control panel with an installed Ethernet card for communication with external devices such as central monitoring stations, computers, and smartphones. The communication occurs over Ethernet using IP services such as email and text messaging through email, IP dialer protocols, and the External Command Protocol.

Up to eight different IP services may be configured for each Ethernet card. The services can be any combination of ECP connections, IP dialer accounts, or email accounts (up to 20 email addresses per email account). A network of panels can support up to 10 ECP connections, 100 IP dialer accounts, and 100 email accounts (up to 20 email addresses per email account).

The installed Ethernet card type determines which IP services are supported (see Table 27 below).

**Table 27: Ethernet card types for IP services**

Supported communication	Required Ethernet card type		
	ETH1	ETH2	ETH3
CU communication with the panel for programming	X	X	X
FireWorks (ECP/IP) gateway communication	X	X	X
IP dialer to CMS communication		X	X
Email and text communication			X

Note: Refer to the *VM-ETH Ethernet Adapter Card Installation Sheet* (P/N 3101794-EN) for installation instructions and specifications. Refer to the VM-CU Help version 1.30 or later for configuring IP dialer and Email communication.

## Ethernet wiring for IP dialer and email communication

Use an RJ-45 Ethernet patch cable, Cat 5e or better, to connect field wiring from the RJ-45 connector on the VM-CPU to communication equipment (see Figure 20 on page 73). The installed Ethernet card model determines the supported communication.

Refer to the *VM-ETH Ethernet Adapter Card Installation Sheet* (P/N 3101794-EN) for wiring details. Install and wire the VM-ETH adapter card in accordance with applicable national and local codes, ordinances, and regulations.

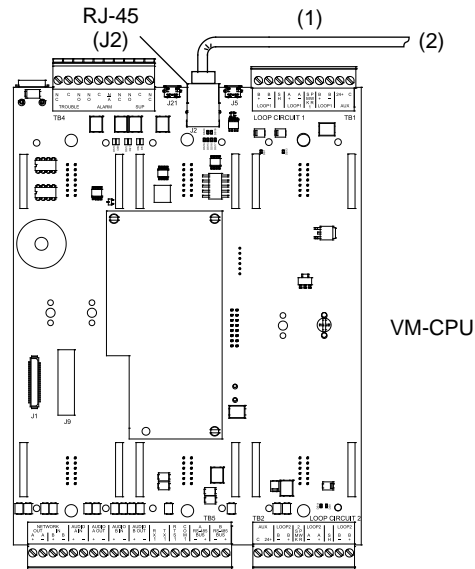
**Figure 20: Ethernet wiring for IP dialer and email communication****Legend**

- (1) RJ-45 Ethernet patch cable, Cat 5e or better
- (2) To a computer with the VM-CU for programming and diagnostics, FireWorks computer, central monitoring station, or SMTP email server

**Notes**

- When not using a dedicated network, consult with the local IT department for firewall port settings.
- When wiring to a building infrastructure switch or hub, consult with the local IT department to obtain the building infrastructure specifications and manufacturer installation sheets.
- When wiring to a CMS receiver or SMTP server, consult with the local IT department for wiring specifications and to obtain manufacturer installation sheets.
- Refer to the VM-CU Help for programming instructions.

**Configuring IP services**

IP services are configured in the VM-CU. Before starting the configuration process, you need to gather configuration settings from the local IT administrator. If the panel will be configured for CMS and FireWorks communication you also need to gather settings from those system administrators. For email and text communication, if no local IT administrator or local SMTP server is available and a public email service will be used, you need to contact the Internet service provider for configuration settings.

To guide you through what information to gather, download the *VM-1 IP Dialer-Email Configuration Worksheet* (P/N 3102341-EN) from the My-Eddie website. To access the website, enter [www.kiddelivesafety.com](http://www.kiddelivesafety.com) in your web browser, click Login to log on to the My-Eddie website, and then locate the worksheet in Media Type > Installation Sheets.

**ECP over IP communication with FireWorks**

The control panel can be configured to communicate system events to a computer running FireWorks that supports IP connections using the Ethernet connection (Gateway Type III). The user-configured External Command Protocol service allows transmission of system events over IP.

Refer to the VM-CU Help for instructions on configuring the ECP service.

### **IP dialer communication with a CMS**

The control panel can be configured to communicate system events to a central monitoring station using an Ethernet connection as an alternative to, or in conjunction with, a plain old telephone service (POTS) dialer such as the VM-DACT.

Refer to the VM-CU Help for instructions on configuring the IP receiver service and receiver accounts.

### **Email and text messaging**

The control panel can be configured to communicate system events to email or text addresses through SMTP servers. Email messages allow communication of multiple or single system events; text messages allow single system events.

For text messaging, a text message is routed to the recipient's wireless service provider phone number email address through a configured SMTP server. The wireless service provider then transmits the message to the recipient's text account. Check with the wireless provider for their carrier gateway address and any additional carrier requirements.

Refer to the VM-CU Help for instructions on configuring the email service and email accounts.

# Chapter 5

# Installation

## Summary

This chapter provides installation information for system components and applications that supplement the instructions provided on individual component installation sheets.

## Content

- UL 864 notification appliance circuit (NAC) signal synchronization 76
- Creating an initial startup database 76
  - Suggestions 76
- System installation sequence 77
  - Sequence list 78
- Component installation 79
  - PS10-4B Power Supply Board 80
  - VM-ELEC chassis hardware and operator layer components 81
  - Digital audio subsystem 83
  - Standby batteries 86
  - Connecting auxiliary/booster power supplies 86
  - Fiber optics 89
- Preliminary field wiring testing 89
- VM-DACT Dual Line Dialer Card 90
  - Line types 91
  - Central Monitoring Station dialing 91
  - Call timers 91
  - Transmission process 91
- Installing the VM-DACT 92
  - Failover operation 95
  - Monitoring and diagnostics 95
- Connecting a MIR-PRT/S serial printer 95
  - Wiring specifications 95
  - DIP switch settings 96
  - Configuring the printer 96
  - Wiring 97
  - System printer backup power supply 98
- Connecting a CDR-3 for coded tone output 99
  - Configuring a CDR-3 for coded tone output 100
- R-Series and K-R-Series annunciator DIP switch settings 104
- Runtime errors 105

## UL 864 notification appliance circuit (NAC) signal synchronization

Table 28 lists the installation requirements for systems that must meet UL 864 NAC signal synchronization requirements.

**Table 28: Installation requirements for UL 864 signal synchronization**

Circuit	Installation requirements
PS10-4B NAC	Emergency evacuation signals are synchronized with main board signaling line circuits on a “per cabinet” basis when you configure the NACs as a Genesis device type and use Genesis notification appliances.
VM-CPU Main Board signaling line circuits	Emergency evacuation signals are synchronized with PS10-4B NACs on a “per cabinet” basis when you use GSA-CC1S or GSA-MCC1S modules configured for auto-sync output (personality code 25) and Genesis notification appliances.
VM-SLCXB module signaling line circuits	Emergency evacuation signals are synchronized on a “per loop” basis when you use GSA-CC1S or GSA-MCC1S modules (personality code 25) and Genesis notification appliances.  Emergency evacuation signals are synchronized on a “per module” basis when you use GSA-CC1 or GSA-MCC1 modules (personality code 5), G1M or G1M-RM Genesis Signal Master modules, and Genesis notification appliances.
GSA-CC1, GSA -MCC1, GSA-CC1S, and GSA-MCC1S	GSA-CC1 modules do not generate temporal signals, they simply turn the NAC circuit on or off. You must configure the notification appliances for temporal or steady output as desired

## Creating an initial startup database

Use the VM-CU software to create the initial startup database. The VM-CU provides extensive instructions for configuring, programming, and testing your VM-1 life safety system. The initial startup database can be useful for the following:

- Assigning panel addresses when you bring up the system for the first time
- Verifying the correct installation of option cards and optional control-indicating module
- Adjusting the gain on an optionally installed VM-PMI and amplifier modules

## Suggestions

When creating the initial startup database:

- Only include the hardware configuration for each cabinet in the system.
- Do not include any device loops in the initial database. The device loops should be installed after verifying the cabinet configuration, and then added to the final database.
- It is not necessary to configure any option cards. They can be added to the final database.

- Save the initial database, and then after installing the option cards define the cabinet configuration and device loops in the VM-CU and save it as a different version. This method eliminates doubling your workload by having to edit two databases as you add cabinets to the system.
- If the cabinet contains amplifiers and a VM-PMI, do the following:
  - From the VM-CU, program a control-indicating module switch to send a 0.7 VRMS, 1 kHz tone to the amplifiers. Label the switch 1KHZ\_TONE and add a correlation similar to the one below to the correlations file.

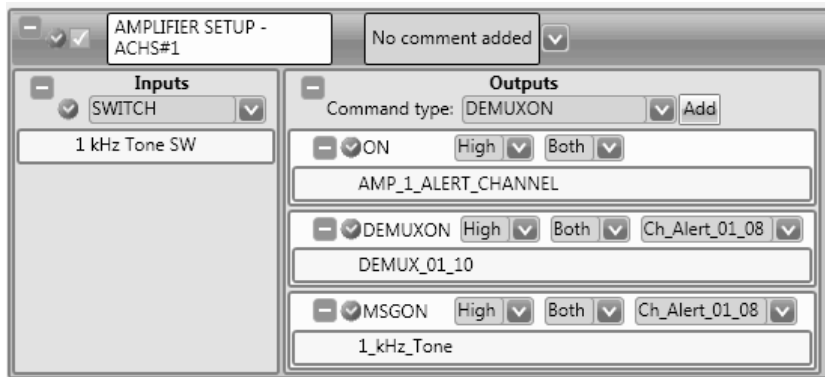

- Record an audio message that consists of the 1 kHz tone in the Audio Message Recorder Clip Library and label it 1KHZ\_TONE. Refer to the VM-CU Help topic for instructions on recording messages.
- If a CDR-3 Bell Coder is installed and connected to the AUX input on a VM-PMI, do the following:
  - From the VM-CU, program a control-indicating module switch to turn on the amplifiers and select the auxiliary channel. Label the switch AUX\_INPUT\_ADJUST and add the following rule to the rules file:

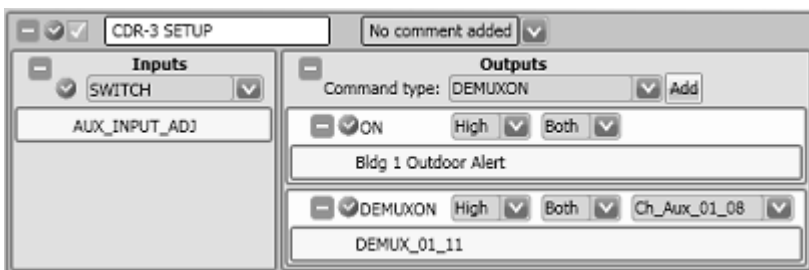

## System installation sequence

Follow these basic instructions when installing a panel. See the installation sheet that came with a component for specific instructions.

### Notes

- Make sure the installation location is free from construction dust and debris, and is not subject to extreme temperature ranges and excess humidity.
- Ensure sufficient floor and wall space, to avoid obstructions during installation and servicing.
- When installing the cabinet, use fasteners that can support the full weight of the cabinet, including standby batteries.
- Be sure to tighten the fasteners firmly to prevent the cabinet from vibrating.
- Remove a panel component from its protective antistatic packaging only for inspection or installation.

- Do not connect standby batteries until initial panel power up (see “Initial power up” on page 34).
- Install the power supply and any half-footprint modules on the backbox and any option cards on the back of the VM-CPU before installing the VM-ELEC assembly. Refer to Figure 21 on page 79 for the footprint locations on the backbox.

## Sequence list

**Note:** Install all control panel components as instructed on the installation sheet that came with the component.

1. Unpack the equipment and make sure it is not damaged. Be sure to remove the installation sheets from component accessory bags.
2. Install the CAB6B Backbox at the required location and pull all the required conductors through the conduit into the backbox.
3. Verify the field wiring. See Table 30 on page 89 “Field wiring tests.”
4. Install the PS10-4B Power Supply Board and any project required half-footprint modules.
5. Install any project required option cards on the back of the VM-CPU. For example, the VM-NOCF for a fiber optic network.
6. Install the VM-ELEC chassis assembly.
7. Install the optional VM-PMI, if required for the project.
8. Power up the panel and download an optional initial startup database. See “Initial power up” on page 34.
9. Install all project required option cards and control-indicating modules on the chassis.
10. Connect field wiring.
11. Define the cabinet configuration, device loops, option cards, etc. for a final VM-CU database, and then download it to the control panel.
12. Install the VMD(G/R) door.

## Component installation

The CAB6B backbox holds the power supply, electronics chassis assembly, option cards, standby power supply batteries, and optional audio subsystem components for the control panel. Figure 21 below shows the footprint areas for each component. See the installation sheet that came with the component for installation instructions.

**Figure 21: CAB6B backbox component footprints**

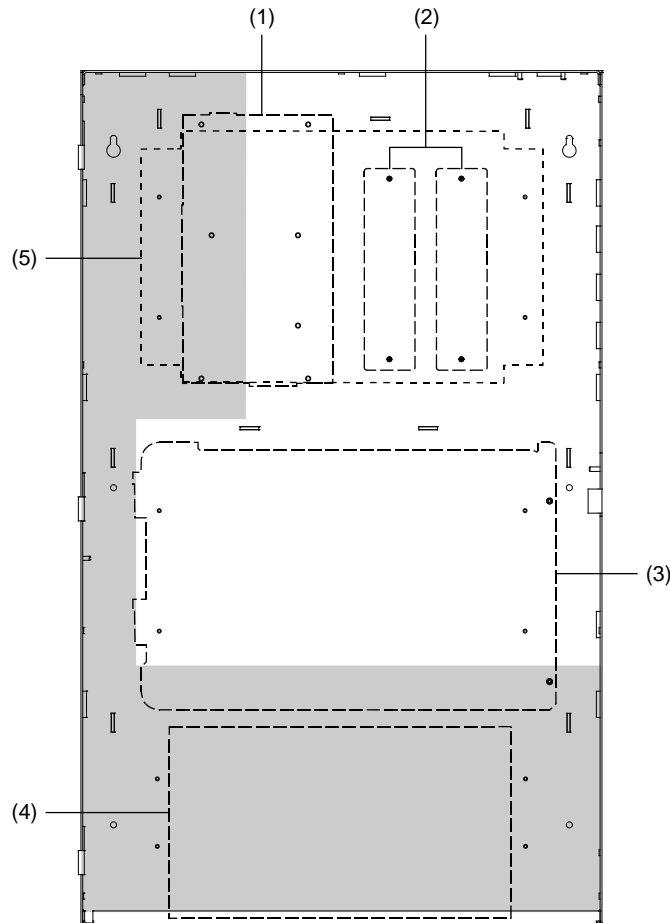

- (1) PS10-4B Power Supply Board mounting area
- (2) Half-footprint module mounting areas
- (3) VM-PMI Paging Microphone Interface mounting area
- (4) Standby battery compartment area
- (5) VM-ELEC Chassis Electronics Assembly mounting area

**Note:** Route nonpower-limited wiring on the shaded area of the cabinet and power-limited wiring on the non-shaded area.

## PS10-4B Power Supply Board

### WARNINGS

- Electrocutation hazard. To avoid personal injury or death from electrocution, make sure the distribution circuit providing mains AC is rendered inoperative prior to connecting mains input wiring to the PS10-4B Power Supply.
- Electrocutation hazard. To avoid personal injury or death from electrocution, remove all sources of power and wait 11 minutes to allow stored energy to discharge before installing or removing equipment.

**Caution:** Circuit boards are sensitive to electrostatic discharge (ESD). To avoid damage, follow ESD handling procedures.

One PS10-4B Power Supply Board is required for each control panel. The power supply provides the required power and related supervisory functions for the control panel as well as filtered, regulated power, and 24 VDC output for operating notification appliances and ancillary equipment.

**Figure 22: PS10-4B Power Supply Board**

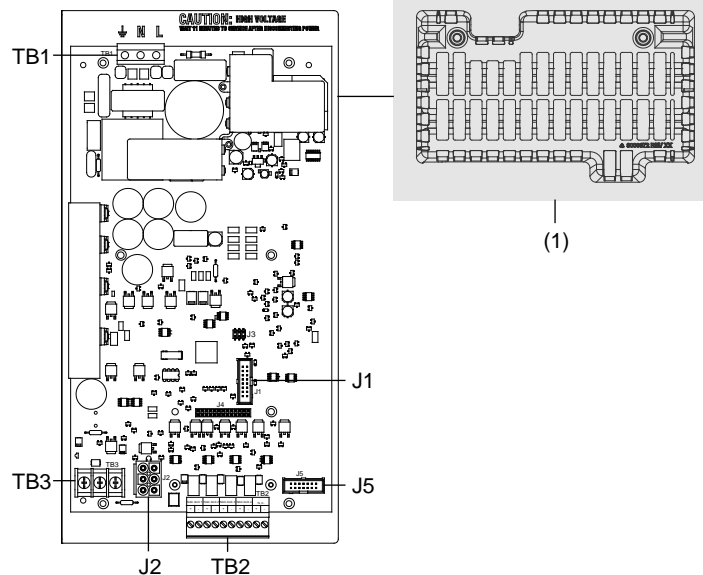

- |   |                                  |
|---|----------------------------------|
| (1) Power supply protective cage used in ULC applications | J5 Audio system connector option |
| J1 Data ribbon cable connector                            | TB1 Mains input wiring           |
| J2 Power supply cable connector                           | TB2 NAC/AUX wiring               |
|   | TB3 Battery wiring               |

On-board terminals and connectors facilitate connection to the VM-CPU, mains input wiring, NAC/AUX wiring, and battery wiring. The 24 VDC rechargeable battery circuit on the power supply board has the capacity to charge up to two 65 Ah sealed lead acid batteries. The CAB6B can house up to two 17 Ah batteries. Install batteries larger than 17 Ah in a separate listed enclosure.

Mains power wiring must be double insulated and connected only to a dedicated 120 V or 230 V mains power distribution circuit with its own disconnect device. Mains input and battery wiring are supervised and nonpower-limited. Route nonpower-limited wiring on the left side of the cabinet, as shown in Figure 21 on page 79. See the *PS10-4B Power Supply Board Installation Sheet* (P/N 3101774-EN) for connecting power supply field wiring and for specifications.

### NAC/AUX power circuits

The PS10-4B provides four 24 V Class B NAC/AUX power circuits. The NAC/AUX terminal marking indicates signal polarity when the circuit is active. Polarity reverses when the circuit is not active. For a list of devices you can connect to special application circuits, see the compatibility list referenced on the control panel.

For notification appliance circuits only, adding an optional CLA-PS10 Class A Adapter card converts the four Class B NAC/AUX power circuits on the PS10-4B power supply card to Class A. See the *CLA-PS10 Class A Adapter Card Installation Sheet* (P/N 3101776-EN) for connecting field wiring and for specifications.

Class B or Class A NAC/AUX circuits configured as NAC outputs are supervised and power-limited. Route power-limited wiring on the right side of the cabinet, as shown in Figure 21 on page 79. For proper circuit supervision, break the wire run at each notification appliance and do not loop wires around notification appliance terminals.

**Note:** NAC/AUX circuits configured as auxiliary power outputs must be turned on and off using a startup correlation. For example, a correlation is needed to turn them off during an AC power failure if they are powering non-life safety devices and you want to preserve battery life.

### VM-ELEC chassis hardware and operator layer components

---

**WARNING:** Electrocutation hazard. To avoid personal injury or death from electrocution, remove all sources of power and allow stored energy to discharge before installing or removing equipment.

---

**Caution:** Circuit boards are sensitive to electrostatic discharge (ESD). To avoid damage, follow ESD handling procedures.

---

The VM-ELEC Chassis Electronics Assembly provides the mounting, internal power, and audio and data distribution for the VM-CPU Main Board, VM-LCD User Interface, the VM-DACT or VM-SLCXB hardware layer option card, and up to three operator layer D12LS-VM Control-Indicating modules. The main board and user interface are preinstalled on the chassis, as are three blank filler plates. The blank filler plates are used to cover empty card spaces when control-indicating modules are not used.

Figure 23 shows hardware and operator layer components installed on the chassis. In the figure, the hardware layer shows the VM-CPU Main Board installed in the first three slots on the chassis and a VM-DACT or VM-SLCXB next to it. The operator layer shows the VM-LCD User Interface, which attaches to the main board, and three optional D12LS-VM control-indicating modules. See the *VM-ELEC Chassis Electronics Assembly Installation Sheet* (P/N 3101780-EN) for connecting field wiring and for specifications.

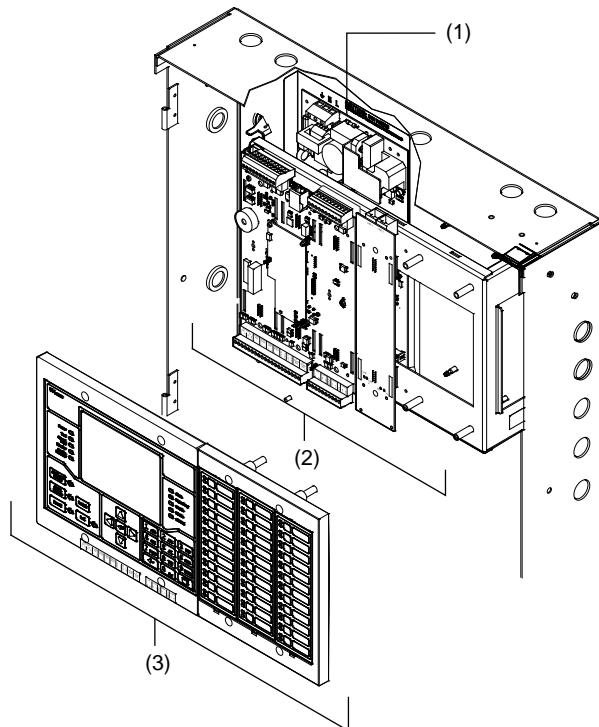
**Figure 23: VM-ELEC chassis hardware and operator layer devices**

- (1) PS10-4B. A protective cage is installed over the power supply for ULC applications
- (2) Hardware layer components (VM-CPU and VM-DACT or VM-SLCXB)
- (3) Operator layer components (VM-LCD and D12LS-VM modules)

### VM-CPU Main Board

The VM-CPU Main Board is a hardware layer board that processes all information from modules installed in the same cabinet and from other control panels on the life safety network. One main board is required for each panel in a VM-1 network. The VM-CPU is always installed on the first three card spaces.

One VM-SLC signaling line circuit card for signaling line circuit 1 (SLC1) is preinstalled on the VM-CPU. The signaling line circuit supports up to 125 detector and 125 module addresses. It also provides dedicated non-resettable 24 VDC for powering conventional two-wire smoke detector circuits on GSA modules. See the *VM-CPU Main Board Installation Sheet* (P/N 3101798-EN) for connecting field wiring and for specifications.

### Option cards

The VM-1 control panel has one card address for an optional VM-DACT card or VM-SLCXB card. It is installed next to the VM-CPU on the electronics chassis. See the “Panel components” section on page 8 for a list of panel options and accessories.

### Notes

- If control-indicating modules are not installed, consider installing the filler plates that came with the VM-ELEC chassis to cover the spaces.
- If the project requires a VM-DACT option card, see “VM-DACT Dual Line Dialer Card” on page 90 for configuration instructions as well as the installation sheet received with the module.
- If the project requires a VM-SLCXB option card, see the *VM-SLCXB Signaling Line Loop Controller Expansion Card Installation Sheet* (P/N 3102128-EN) for installation instructions and specifications.

## VM-LCD User Interface

The VM-LCD is an operator layer module that interfaces with the VM-CPU to provide indicators and user controls for the control panel. Only one VM-LCD is required to provide a point of control for the entire network. Additional user interfaces can be added to any VM-1 control panel in the VM-1 network to provide additional points of control. See the *VM-LCD User Interface Installation Sheet* (P/N 3101781-EN) for installation instructions and specifications.

## D12LS-VM Control-Indicating modules

D12LS-VM Control-Indicating modules are operator layer modules that provide additional operator interface capability. They can be mounted on any of the last three card addresses on the VM-ELEC chassis (see Figure 23 on page 82). See the *D12LS-VM Control-Indicating Module Installation Sheet* (P/N 3101793-EN) for installation instructions and specifications.

## Digital audio subsystem

---

**WARNING:** Electrocution hazard. To avoid personal injury or death from electrocution, remove all sources of power and allow stored energy to discharge before installing or removing equipment.

---

**Caution:** Circuit boards are sensitive to electrostatic discharge (ESD). To avoid damage, follow ESD handling procedures.

---

## VM-PMI Paging Microphone Interface

The VM-PMI provides controls for emergency voice and alarm communications in the audio subsystem. The interface is installed on the backbox, below the VM-ELEC assembly (see Figure 24 on page 84). It consists of an audio mounting bracket, EAEC Emergency Audio Evacuation Controller card, audio enclosure, and paging microphone. In the VM-CU, the VM-PMI is identified in the cabinet configuration as ASU, under Rail 2 Type (Configure > Cabinet).

See “Digital audio subsystem” on page 60 for detailed information on the VM-PMI. See the *VM-PMI Paging Microphone Interface Installation Sheet* (P/N 3101788-EN) for installation instructions and specifications.

## VM-MFK Firefighter Telephone Kit

The VM-MFK Master Firefighters telephone provides two-way communication between firefighters in the building and the Fire Command Center. You can also use the telephone handset as the paging microphone.

See “Digital audio subsystem” on page 60 for detailed information on the VM-PMI. See the *VM-MFK Master Firefighter Telephone Kit Installation Sheet* (P/N 3101790-EN) for installation instructions and specifications.

**Figure 24: VM-PMI Paging Microphone Interface and VM-MFK Fire Fighter Telephone**

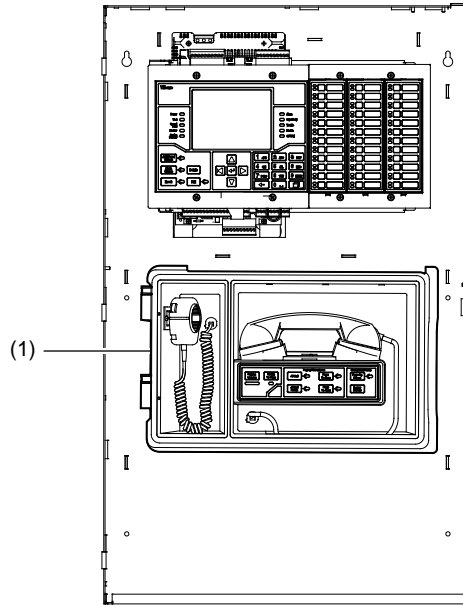

(1) VM-PMI Paging Microphone Interface and VM-MFK Fire Fighter Telephone

**Digital audio wiring**

The control panel supports up to three ACHS Audio Channel Selector cards that convert digital audio from an EAEC card into an analog preamp signal. The audio riser consists of a single pair (Class B) or two pairs (Class A or Class X) of wires that connect together all SIGA-AA30/50 amplifiers housed in a separate cabinet. Since the digital signals are multiplexed, any of independent audio sources can be directed to any amplifier connected to the network. All command and control signals for the audio system are distributed over the network data riser. See the *ACHS Audio Channel Selector Installation Sheet* (P/N 3101791-EN) for installation and specifications.

Figure 25: ACHS Class B wiring to an external SIGA-AA30/50 amplifier

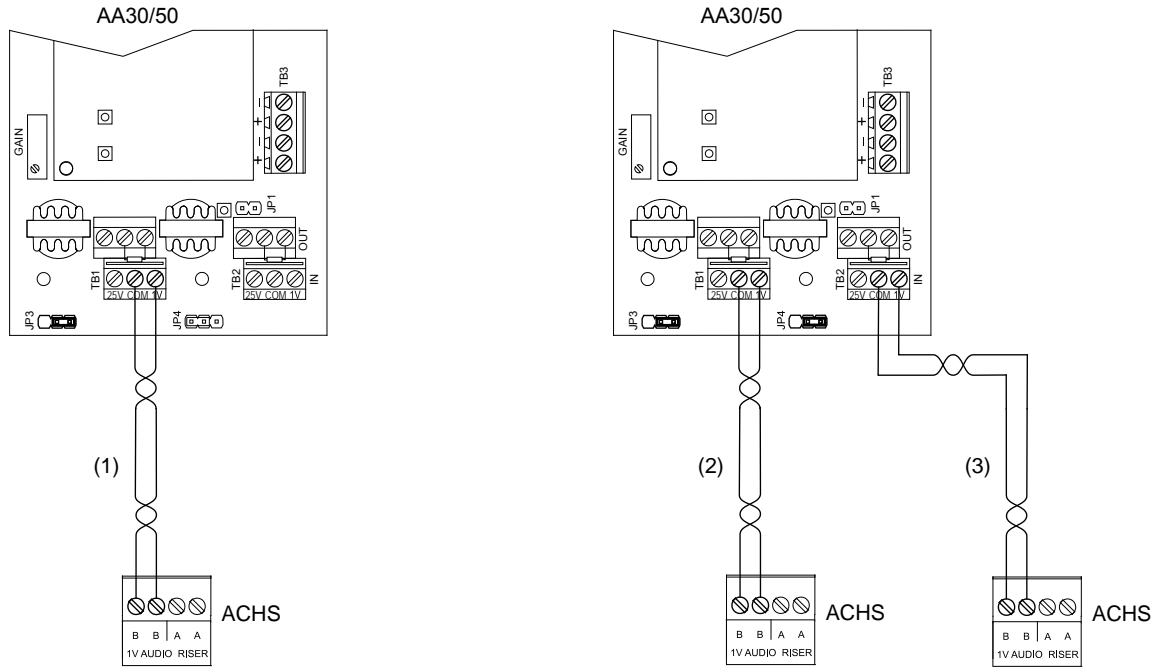

- (1) Channel 1 audio in
- (2) Channel 1 audio in, Alert
- (3) Channel 2 audio in, EVAC

Figure 26: ACHS Class A wiring to an external SIGA-AA30/50 amplifier

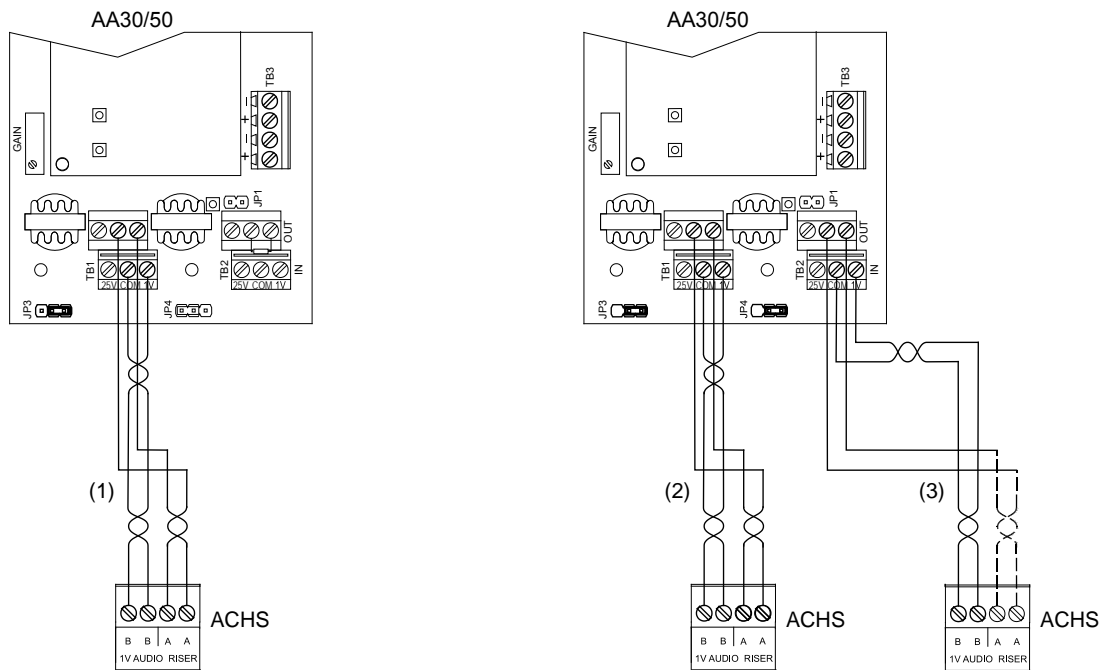

- (1) Channel 1 audio in
- (2) Channel 1 audio in, Alert
- (3) Channel 2 audio in, EVAC

## Standby batteries

**Caution:** To avoid damage to equipment, do *not* connect standby batteries unless the control panel is already powered up using AC power. See “Initial power up” on page 34.

To provide continued panel operation in the event mains power is interrupted, the 24 VDC rechargeable battery circuit on the PS10-4B Power Supply has the capacity to charge up to two 65 Ah sealed lead acid standby batteries.

Up to two 17 Ah sealed lead acid standby batteries can be housed on the battery tray in the CAB6B backbox (see Figure 21 on page 79 for the compartment location). Install batteries larger than 17 Ah in a separate listed enclosure.

Use the diagram in Figure 27 when connecting the battery wiring to the power supply. Before connecting the batteries, confirm the panel is already powered up using AC power.

**Figure 27: Wiring standby batteries to the power supply**

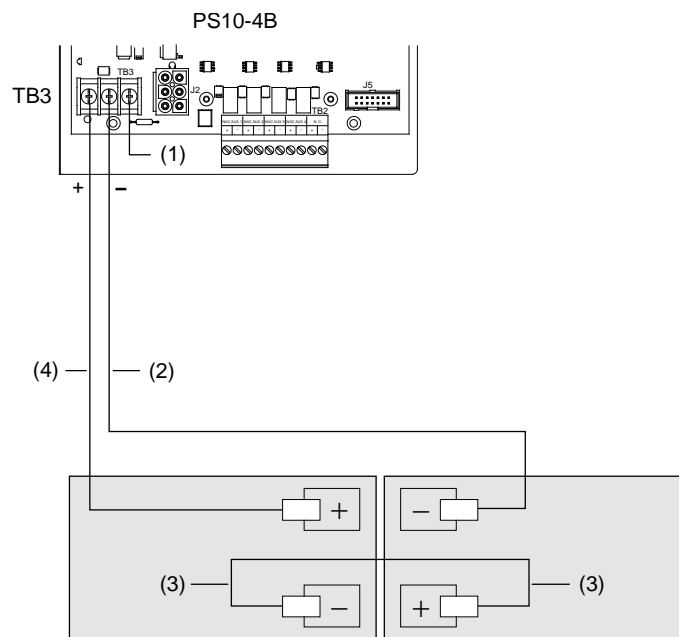

(1) No connection

(2) Black wire from standby battery

(3) Blue wire

(4) Red wire from standby battery

## Connecting auxiliary/booster power supplies

UL requires that you monitor secondary power sources housed in auxiliary and booster power supply enclosures for loss of AC power to ensure that:

- Upon loss of AC power, the control panel must provide an audible and visible trouble signal.
- Remote station, central station, and proprietary-type protected premises units must transmit a trouble signal off-premises.

To meet UL requirements you need to connect a GSA-CC1 (or GSA-CC1S) and a GSA-CT1 to the booster supply. The GSA-CC1 is used to activate the booster supply and to signal common troubles. The GSA-CT1 is used to signal booster supply AC power failures.

Mount the GSA-CC1 and GSA-CT1 inside the booster supply cabinet as described in the technical documentation received with booster supply. Connect field wiring as shown in Figure 28 on page 88.

### Booster power supply configuration

Set DIP switches SW 2-6 to On. This configures the booster supply's trouble relay to close only on loss of AC power. All other booster troubles are signaled through the sense circuits.

**Note:** In Figure 28, the booster supply is configured so that Sense 1 controls all four NACs. For DIP switch settings for this and other booster supply configurations see the technical documentation received with the booster supply.

### GSA modules configuration

Configure the GSA-CC1 and GSA-CT1 modules as shown in the table below.

**Table 29: GSA-CC1 and GSA-CT1 configuration settings**

Module	Properties
GSA-CC1	Device Type = COMMONALARMOUTPUT Personality = (5) Signal - supervised output (Class B) Text 1 = REMOTE_SUPPLY Text 2 = SENSE_1
GSA-CT1	Model = CT1 Device Type = ACFAIL Personality = (3) Active - NO nonlatching (Class B) Text 1 = REMOTE_SUPPLY Text 2 = AC_FAILURE

Figure 28: Typical booster power supply wiring

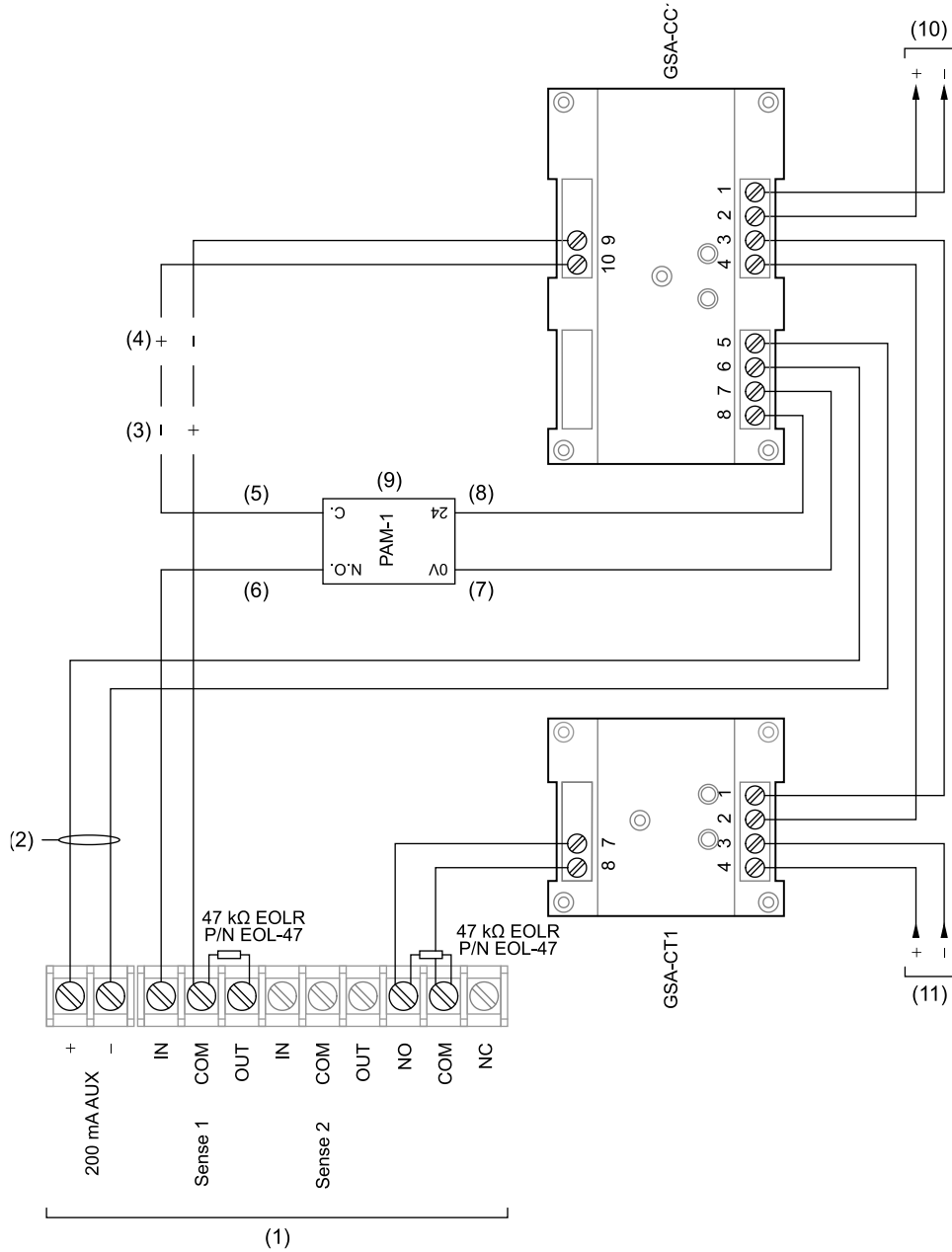

- (1) Auxiliary/booster supply
- (2) Not supervised
- (3) Normal
- (4) Active
- (5) Blue
- (6) Orange
- (7) White
- (8) Red
- (9) Install a PAM-1 or equivalent listed relay only when required to supervise the 200 mA AUX circuit wiring
- (10) Data Out, Signaling line circuit to next device
- (11) Data In, Signaling line circuit from previous device

## Fiber optics

Use the VM-NOCF Fiber Network Option Module for a fiber optic and combination fiber optic and RS-485 communication path for up to eight VM-1 control panels. See the *VM-NOCF Fiber Network Option module Installation Sheet* (P/N 3101783-EN) for installation, wiring, and specifications.

## Preliminary field wiring testing

It is recommended that you test all circuits before they are connected to the control panel components. Table 30 indicates the recommended tests and acceptable test results.

**Note:** Individual devices are not checked as part of these tests. All equipment installed on field circuits must be individually tested to ensure proper operation when the system running.

**Table 30: Field wiring tests**

Circuit type	Test
DC notification appliance circuit	<ol style="list-style-type: none"> <li>1. Measure the resistance between conductors. The circuit resistance should be infinite if no devices are installed on the circuit. The circuit resistance should be approximately 15 k<math>\Omega</math> when the polarized notification appliances and the end-of-line resistor are correctly installed.</li> <li>2. Reverse the meter leads. The circuit resistance between conductors should read approximately 10<math>\Omega</math> to 20<math>\Omega</math>. If the resistance reading is still approximately the same value when the meter leads are reversed, one or more polarized devices are installed incorrectly.</li> <li>3. Measure the resistance between each conductor and earth ground. The resistance should be infinite.</li> </ol>
Audio notification appliance circuit	<ol style="list-style-type: none"> <li>1. Measure the resistance between conductors. The circuit resistance between conductors should be infinite if no devices are installed on the circuit. The circuit resistance should be approximately 15 k<math>\Omega</math> when the polarized notification appliances and the end-of-line resistor are correctly installed.</li> <li>2. Reverse the meter leads. The circuit resistance between conductors should still read approximately 15 k<math>\Omega</math>.</li> <li>3. Measure the resistance between each conductor and earth ground. The circuit resistance between a conductors and earth ground should be infinite.</li> </ol>
Signaling line circuits	<ol style="list-style-type: none"> <li>1. With field wiring disconnected, verify the continuity of each conductor. Each conductor should measure less than 38<math>\Omega</math>.</li> <li>2. Measure the resistance between conductors. The circuit resistance between conductors should be infinite if no devices are connected to the circuit. The circuit resistance between conductors should be between approximately 18 k<math>\Omega</math> (250 devices) and 4.5 M<math>\Omega</math> (1 device) when devices are installed.</li> <li>3. Measure the resistance between each conductor and earth ground. The circuit resistance between a conductors and earth ground should be infinite.</li> </ol>

Circuit type	Test
Addressable analog circuits	<ol style="list-style-type: none"> <li>1. Verify the continuity of each conductor. Each conductor should measure less than 50 <math>\Omega</math>.</li> <li>2. Measure the resistance between conductors. The circuit resistance between conductors should be infinite if no devices are connected to the circuit.</li> <li>3. Measure the resistance between each conductor and earth ground. The circuit resistance between a conductors and earth ground should be infinite.</li> </ol>
Traditional initiating device circuits	<ol style="list-style-type: none"> <li>1. Verify the continuity of each conductor.</li> <li>2. Measure the resistance between conductors. The circuit resistance between conductors should be infinite if no devices are connected to the circuit. The circuit resistance between conductors should be approximately 4.7 k<math>\Omega</math> when devices are installed.</li> <li>3. Measure the resistance between each conductor and earth ground. The circuit resistance between a conductors and earth ground should be infinite.</li> </ol>
RS-485 communication circuits	<p>The VM-1 system uses RS-485 circuits for the network data riser and network audio riser.</p> <ol style="list-style-type: none"> <li>1. Verify the continuity of each conductor. Each conductor should measure between 0 and 50 <math>\Omega</math>.</li> <li>2. Measure the resistance between conductors. The circuit resistance between conductors should be infinite if no devices are connected to the circuit. The circuit resistance between conductors should be approximately 50 <math>\Omega</math> when devices are installed.</li> <li>3. Measure the resistance between each conductor and earth ground. The circuit resistance between a conductors and earth ground should be infinite.</li> </ol>
RS-232 Communication Circuits	<p>With both ends of the circuit disconnected:</p> <ol style="list-style-type: none"> <li>1. Verify the continuity of each conductor. Each conductor should measure between 0 and 25 <math>\Omega</math>.</li> <li>2. Measure the resistance between conductors. The circuit resistance between conductors should be infinite.</li> <li>3. Measure the resistance between each conductor and earth ground. The circuit resistance between a conductors and earth ground should be infinite.</li> </ol>
Earth Ground	<p>Measure the resistance between the earth ground terminal and a convenient water pipe or electrical conduit. The circuit resistance should be less than 0.1 <math>\Omega</math>.</p>

## VM-DACT Dual Line Dialer Card

The VM-DACT Dual Line Dialer Card is a hardware layer option card that connects the VM-1 system to a public switched telephone network or cellular network when used with a compatible cellular capture module. The module has two 8-position modular jacks for connecting two loop-start lines.

**Note:** Refer to the *VM-1 Compatibility List* (P/N 3101804-EN) for a list of compatible cellular capture modules. Refer to the *Cellular Capture Module Configuration Application Guide* (P/N 3102371-EN) for model-specific programming and wiring requirements.

The VM-DACT can support 255 accounts and communicate with 80 receivers in the Contact ID protocol.

The VM-DACT configuration settings made in the VM-CU define the line properties, receiver attributes, account parameters, and transmission details.

## Line types

The VM-DACT can be configured as a one- or two-line dialer, a modem, or a modem and one- or two-line dialer.

## Central Monitoring Station dialing

The VM-DACT electronically dials receivers in the CMS using either pulse or tone dialing, as specified in the VM-CU. The module dials the stored CMS telephone number using the same digits that would be used if a person were dialing from the premises with an ordinary telephone.

## Call timers

The VM-DACT sends messages in order of their priority. Messages may include device and user ID information regarding events, such as openings, closings, alarms, and tamper or trouble events. The module waits for acknowledgement that each message sent has been received. Where necessary, the VM-DACT can be configured to begin dialing without waiting for a dial tone. This option is used in areas where the telephone line has an absent or erratic dial tone.

## Transmission process

The VM-DACT includes features that provide an appreciable level of transmission integrity. Multiple telephone lines and multiple telephone numbers help to ensure that a call to the receiver gets through.

The VM-DACT module sequences through the following basic steps to contact the CMS receiver.

1. The VM-DACT seizes one of the telephone lines and puts the line on-hook for a minimum of 3 seconds.

This cuts off any ongoing call and disconnects the line from any telephone or dialing devices that are connected downstream.

**Note:** The module tries to select an unused line for its first two attempts.

2. The VM-DACT takes the line off-hook and waits for a dial tone.

The Line 1 or Line 2 LED indicates.

If a dial tone is not received by the configured time, the module goes on-hook, increments the attempt counter, and continues to alternate lines and numbers until a dial tone is acquired.

If the VM-DACT is configured with two telephone numbers and only one telephone line, it will make four attempts using the first telephone number, then four attempts using the second telephone number. This alternation of telephone numbers continues as needed until a connection is made or the configured number of dial attempts has been made.

**Note:** In areas where the telephone system has no dial tone, or where the dial tone is erratic, you can configure the VM-DACT to dial without waiting for a dial tone.

3. The VM-DACT dials the CMS using the programmed dialing mode and telephone number.

4. The VM-DACT waits for a handshake message from the CMS, indicating that a connection has been established.

If a handshake is not received within 40 seconds, the module puts the telephone line on-hook and waits for the configured period.

After the wait, processes 2 through 4 are repeated. If the module is still unable to contact the receiver, it seizes the other telephone line and repeats two attempts. If still unable to contact the receiver, it switches back to the first telephone line and attempts to contact the receiver using the secondary telephone number. If still unable to contact the receiver, the module continues to alternate lines and numbers until the configured maximum number of attempts have been reached. If the maximum number of attempts is reached, the module sends a trouble message to the VM-CPU. The module retries the full number of attempts if another event is activated or makes one attempt if a configured period (Wait Time Between Attempts) expires.

5. When the call is completed, ringing is detected by the CMS dialer-receiver (DACR). The DACR goes off-hook and transmits a handshake.
6. If the handshake matches the desired transmit format, the VM-DACT transmits, in the specified format, all premises event data.

The Line 1 or Line 2 LED flashes to indicate data is being transmitted.

7. The VM-DACT waits for an acknowledgement and a shutdown signal from the CMS receiver, and then puts the line on-hook, ending the call.

The Line 1 or Line 2 LED stops indicating.

## Installing the VM-DACT

When installing the VM-DACT, follow these general steps:

1. Identify suitable telephone company lines and services.
2. Install the VM-DACT module on the electronics chassis.
3. Connect the VM-DACT to telephone company lines.
4. Download configuration data from the VM-CU.
5. Make test transmissions to verify proper operation.

### POTS line requirements

The VM-DACT is supplied with two 7-foot cables that are 8-conductor, flat telephone cables, with 8-position modular plugs on both ends. One end of the cable plugs into the VM-DACT. The other end plugs into an RJ-31X jack. You must obtain the RJ-31X jack locally.

**Note:** For cellular capture module line requirements, refer to the *VM-DACT Dual Line Dialer Card Installation Sheet* (P/N 3101786-EN). For cellular capture module model-specific programming and wiring requirements, refer to the *Cellular Capture Module Configuration Application Guide* (P/N 3102371-EN).

---

**WARNING:** Failure to use an RJ-31X jack violates FCC and NFPA regulations. A telephone connected directly to the incoming telephone line without the proper use of the RJ-31X jack will cause a telephone company trouble when used and possibly prevent the dialer from getting through to the CMS receiver in an emergency.

---

- The RJ-31X jack must be used to connect each line of the VM-DACT to the switched telephone network. One jack is required for each telephone line.

The 8-position jack has a special jumper between terminals 1 and 4, and 5 and 8. This jumper is in place when the plug is removed from the jack.

Removing the plug re-establishes connection to the premises telephones. Inserting the plug opens the jumper and connects the VM-DACT, which provides a series connection to the telephones.

See the *VM-DACT Dual Line Dialer Card Installation Sheet (P/N 3101786-EN)* for a diagram of the jack wiring.

- VM-DACT dialers can be used for most applications that use telephone lines. The exceptions are:
  - The central station telephone number cannot be dialed directly (using access numbers and area code where necessary) without operator interception of the call
  - Multiparty service (a party line) exists
  - Operator assistance is required to complete a telephone call and a foreign exchange cannot be introduced
  - Connection is not established within 38 seconds following completion of dialing
- The VM-DACT dialer circuit is compatible with any switched telephone network that employs direct dialing (local) and Direct Distance Dialing (DDD), without operator interception of the call.
- Operator interception occurs in some areas where message billing is not completely automatic. Where operator interception is involved, you must obtain a foreign exchange (FX) connection from the central station exchange to the exchange serving the customer. The FX provides a local number for calling the central station without toll billing. A WATS or ground-start line connection must not be used for this purpose because the line cannot be supervised.
- The VM-DACT includes a feature that prevents jamming by an incoming telephone call. The feature is based on a telephone service option referred to as called party disconnect. This option lets the receiver of a call disconnect by hanging up the telephone for a period of time, even if the caller stays on the line. The time required for disconnect varies in different areas, but is usually between 18 and 90 seconds. Called party disconnect is available in most areas. To determine whether the called party disconnect control is available in the area to be served, consult the local telephone company.

In areas not having called party disconnect, the VM-DACT module is vulnerable to jamming by an incoming call. To minimize the possibility of jamming, we recommend that the customer order a separate, unlisted number for exclusive use of the VM-DACT module. The customer should keep this number confidential. In the case of the two-line dialer, two premises telephone numbers would have to be busied by incoming calls to jam the system.

Progressive anti-jamming measures would entail the use of one unlisted telephone number, or two unlisted numbers for maximum dialer integrity.

- The VM-DACT must be connected to the incoming line ahead of all connected equipment on that line, but just behind the demarcation block. This puts the control unit telephone connection in series, assuring that all telephones, answering machines, and FAX machines are disconnected during dial-out to the CMS. This requirement is necessary so the VM-DACT dialer circuit can seize the line for its exclusive use in the event of an alarm.
- Using a telephone line that is considered essential for conducting business at the site is not preferred. The dialer must be the first connection in line because it seizes the line and disconnects all other equipment when making a call. If connection will be made to a telephone company line that is also used for normal business purposes, advise the customer that the telephone service will be disrupted for a few minutes during the connection period.
- If the incoming lines to the protected premises involve a rotary telephone line arrangement, make the connection to the line having the highest number. This will create the least interference with business lines.
- In areas where the telephone company requires their own connector block be installed, it should be wired as per the USOC RJ-31X or RJ-38X configuration. (The RJ-38X configuration is identical to RJ-31X except for a jumper between 2 and 7 that is used in some residential applications but is not used by the VM-DACT.)

- When the VM-DACT is configured as a two-line dialer module, two incoming lines must be used and connections must be made to each line.

### Installing the VM-DACT module

See the *VM-DACT Dual Line Dialer Card Installation Sheet* (P/N 3101786-EN) for installation instructions, wiring, and specifications.

### Connecting the VM-DACT to telephone company lines

#### Notes

- For an NFPA 72 compliant system, the VM-DACT must be connected to loop-start telephone lines. If the site has ground-start lines, two separate loop-start lines must be installed for the dialer.
- If the installation is for a certified fire alarm system or a burglar alarm system in compliance with NFPA 72, the telephone company line must be of the called party disconnect type (also called timed-release disconnect). This feature permits the communication module to seize the line and dial out, even when the telephone company line is in use.
- For connecting the VM-DACT to a cellular capture module for communication over a digital cellular network, refer to the *VM-DACT Dual Line Dialer Card Installation Sheet* (P/N 3101786-EN). For cellular capture module model-specific programming and wiring requirements, refer to the *Cellular Capture Module Configuration Application Guide* (P/N 3102371-EN).

#### To determine the type of telephone company line:

1. Disconnect the line pair and connect the lines to a test meter.

If the line is equipped for loop-start, the meter should read 48 to 52 VDC between the lines.

If the line is equipped for ground-start, the meter will read 0 VDC between the lines, 48 to 52 VDC between one line and ground, and 0 VDC between the other line and ground.

#### To determine whether the telephone line supports called party disconnect:

1. Have someone telephone the premises from the outside.
2. Hang up the telephone that received the call, but have the individual who placed the call remain on the line.
3. After 40 seconds, pick up the called telephone again to determine whether the caller has been disconnected.

### Downloading the configuration database

After installing the VM-DACT and configuring its database in the VM-CU, download the database. See "Downloading a database" on page 51 for download instructions.

**Note:** For UL listed or FM approved installations, you must configure the VM-DACT as a two-line dialer and both lines must have supervision (line-cut detection) selected.

### Testing the transmission

The VM-CU provides a report that lists all CMS codes that can be transmitted from the VM-DACT. Give this report to the appropriate CMS.

After the CMS has programmed the central monitoring database, perform transmission tests as required by the local authority having jurisdiction (AHJ) and CMS.

**Note:** Transmission failures are latched at the panel. You must reset the panel in order to clear them.

## Failover operation

To address the possibility of a communication failure or device trouble, you can create a failover operation in the VM-CU for the VM-DACT. Failover operates by enabling and disabling various accounts defined for the project. On detection of a fault or trouble, project correlations disable accounts on the failed VM-DACT and enable matching accounts on the backup VM-DACT.

Failover operation results in a system that is resistant to trouble arising from telephone lines, VM-DACTs, or the VM-CPU module. The operation can be limited to a single panel or can span two or more panels anywhere in a network.

In systems with a single VM-DACT, you can include a second VM-DACT that acts as a redundant unit. In systems with two or more VM-DACTs, you can program the system so that the units back up each other, while still handling their normal traffic.

## Monitoring and diagnostics

See “LED indicator diagnostics” on page 131 for the LED states.

## Connecting a MIR-PRT/S serial printer

The MIR-PRT/S serial printer can be connected to a VM-1 panel to provide a printout of system events such as status changes, active events, and reports. The printer is an 80-character line width, freestanding printer that uses standard form feed paper.

**Figure 29: MIR-PRT/S serial printer**

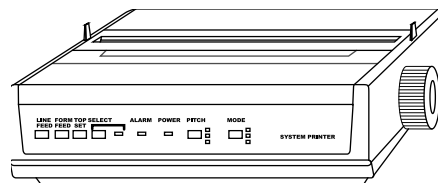

An illustrated setup guide is included with the printer that contains detailed instructions for assembling the printer, installing the print drivers, and performing other basic tasks. Refer to the guide when unpacking, assembling, and setting up the printer. A user guide is provided on the CD included with the printer. Refer to the user guide for instructions on using the front panel to configure printer settings.

### Notes

- For supervised printers, use MIR-PRT/S printer model D22300A (120 V).
- If connecting the MIR-PRT/S printer to a serial port that is shared with a CDR-3 Bell Coder, refer to “Connecting a CDR-3 for coded tone output” on page 99.

## Wiring specifications

Length: 50 ft (15.2 m) max.

Resistance: 13  $\Omega$  max.

Wiring: 22 AWG (0.50 mm<sup>2</sup>)

## DIP switch settings

### Supervised printer

**Table 31: Supervised printer DIP switch settings**

	Switch							
	1	2	3	4	5	6	7	8
<b>SW1</b>	On	On	On	On	On	On	On	On
<b>SW2</b>	On [1]	Off [1]	On [1]	Off	Off	On	On	On

[1] Recommended baud rate is 4800 bps

### Unsupervised printer

**Table 32: Unsupervised printer DIP switch settings**

	Switch							
	1	2	3	4	5	6	7	8
<b>SW1</b>	On	On	On	Off	On	On	On	On
<b>SW2</b>	On [1]	Off [1]	On [1]	Off	Off	On	On	On

[1] Recommended baud rate is 4800 bps

## Configuring the printer

1. Configure the printer port using the VM-CU.  
For the Baud Rate, see Table 31 or Table 32 on page 96 (if not shown, select 4800 bps).
2. Remove the screw from the DIP switch cover on the back of printer. See Figure 30.
3. Set the printer DIP switches as shown in Table 31 or Table 32.
4. Replace the DIP switch cover.

**Figure 30: MIR-PRT/S printer DIP switch cover**

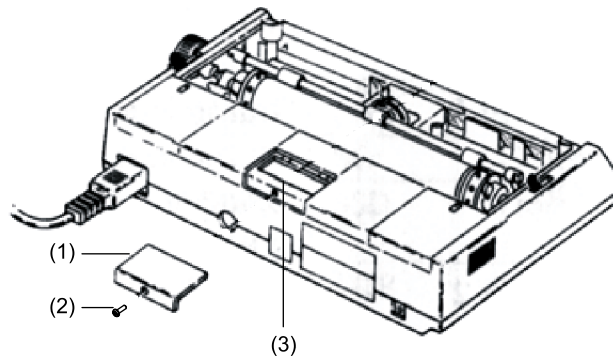

(1) DIP switch cover

(2) DIP switch cover screw

(3) DIP switches

## Wiring

---

**WARNING:** Electrocution hazard. To avoid personal injury or death from electrocution, remove all sources of power and allow stored energy to discharge before installing or removing equipment.

---

### Notes

- Use a serial cable with a 25 pin, D-Sub male connector on one end. The cable can be purchased locally or constructed using the DB-25 connector provided with the printer.
- Serial printer connections are power-limited and may or may not be supervised, depending on the control panel.
- Locate supervised serial/USB printers in the same room as the equipment to which they connect.
- Locate unsupervised serial/USB printers in the same room and within 20 ft. (6.1 m) of the equipment to which they connect. Enclose wiring in conduit or equivalent protection against mechanical injury.
- Serial connection requires UL Listed and CSA Approved shielded RS-232C cable. Cable length may not exceed 50 ft. (15.2 m).

### Serial cable requirements

- Shielded RS-232C cable, UL and CSA approved
- DB-25 serial connector (included with the printer)

### To build the serial cable:

1. Cut the cable to the length required for your application (20 ft (6 m) max.).
2. Wire one end of the cable to the pins on the DB-25 connector. See Figure 31 on page 98.

### To connect the serial cable to the control panel:

1. Plug the DB-25 serial connector into the serial port on the back of the printer.
2. Wire the other end of the cable to TB5 on the VM-CPU. See Figure 31.

**Figure 31: Serial printer wiring**

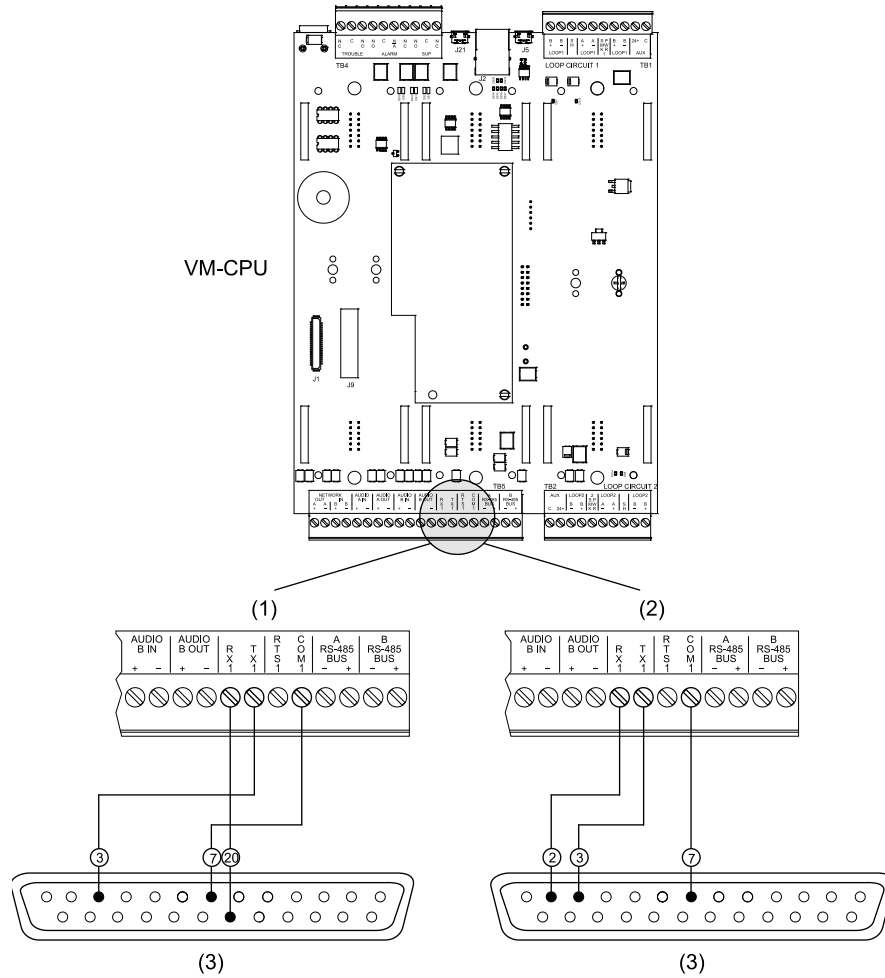

- (1) For a supervised serial printer
- (2) For an unsupervised serial printer

- (3) Front view of male DB-25 connector

### System printer backup power supply

If the MIR-PRT/S printer is required to operate during a brownout conditions or AC power failure, install an uninterruptible power supply (UPS). See Figure 32 on page 99.

The UPS should be UL Listed for fire protection (UTRZ) and provide 120 VAC at 50/60 Hz for at least 24 hours. If the printer is required to operate during brownout conditions or AC power failures, install a UL Listed (UTRZ) uninterruptible power supply that can maintain printer operating voltage for at least 24 hours.

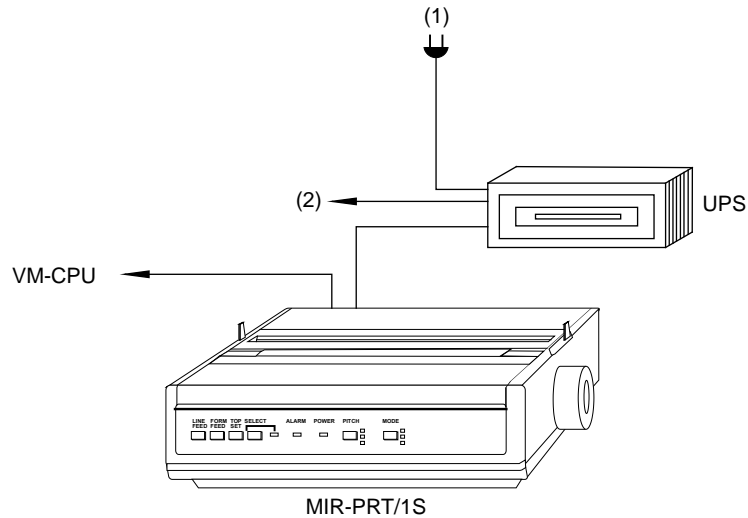
**Figure 32: Uninterruptible power supply wiring**

- (1) 120 VAC, 15 A circuit  
 (2) UPS trouble contact monitor

## Connecting a CDR-3 for coded tone output

The CDR-3 Bell Coder module can be connected to the AUX input on the VM-PMI EAEC card to provide a coded or march time tone to the audio system. See Table 33 below for power and installation specifications.

**Table 33: CDR-3 power and installation specifications**

Input power	
Input voltage	24 VDC nominal
Standby current	60 mA
Current	
Standby	60 mA
Alarm	100 mA
Mounting	Half-footprint space on the back of the CAB6 backbox (see Figure 21 on page 79 for the footprint location)

When connecting a CDR-3 to a serial port that is shared with an MIR-PRT/S printer, you must connect both devices using an IOP3A.

### IOP3A isolator module

The IOP3A isolator module provides two RS-232 connections that allow you to connect a CDR-3 for coded tone output when a MIR-PRT/S printer is connected to the control panel. See Table 34 for power and installation specifications.

**Table 34: IOP3A power and installation specifications**

Input power	
Voltage	24 VDC nominal
Standby current	60 mA
Isolated power output	
Voltage	12 VDC
Current	10 mA max.
Mounting	Half-footprint space on the back of the CAB6 backbox (see Figure 21 on page 79 for the footprint location)

Note: All *unsupervised* RS-232 connections must be in the same room, within 20 ft. (6.1 m), and enclosed in conduit or equivalent protection against mechanical injury.

## Configuring a CDR-3 for coded tone output

Refer to the Figure 34 wiring diagram on page 102 for a CDR-3 coded tone output application. If your control panel setup includes a MIR-PRT/S printer, refer to the Figure 35 wiring diagram on page 103. Refer to the information below for configuration settings.

### Configuration settings

- Set the CDR-3 parity DIP switch S1-6 to ON (no parity) as shown in Figure 33 on page 101.
- Refer to the *CDR-3 Bell Coder Installation Sheet* (P/N 3100023) for other settings and specifications.
- For a combined CDR-3 and MIR-PRT/S printer application:
  - Set the CDR-3 baud rate DIP switches S1-7 and S1-8 (see Figure 33 on page 101), and the MIR-PRT/S baud rate. The recommended rate is 2400 bps.
  - Configure the VM-CU Cabinet Configuration > Ports > Port Type to CDR-3/Printer and the Baud Rate to the same rate as the CDR-3 and printer.
  - Set the IOP3A DIP switch S1 to UP (enables outputs 1 and 2; disables DB9 and RJ12 connectors).
  - Set the IOP3A jumpers as follows:
    - Jumper JB1: Pins 2-3 (Supervision Mode) (Note: Jumpers JB1 and JB4 settings must agree)
    - Jumper JB2 (Output 1): IN for an unsupervised printer (disables 12 VDC on TB2-1); OUT for a supervised printer (enables TB2)
    - Jumper JB3 (Output 2): IN (disables 12 VDC on TB3-1)
    - Jumper JB4: IN (Supervision Mode) (Note: Jumpers JB1 and JB4 settings must agree)

**Note:** After configuring and wiring the CDR-3, adjust zoned amplifier output levels and the VM-PMI EAEC auxiliary input gain as necessary.

Figure 33: CDR-3 parity and baud rate settings

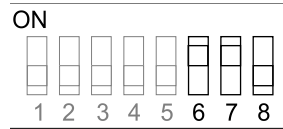

S1-6	S1-7	S1-8	Description
ON	–	–	No parity
–	OFF	OFF	1200 baud
–	OFF	ON	2400 baud
–	ON	OFF	4800 baud (factory default)
–	ON	ON	9600 baud

Figure 34: CDR-3 wiring for coded tone output

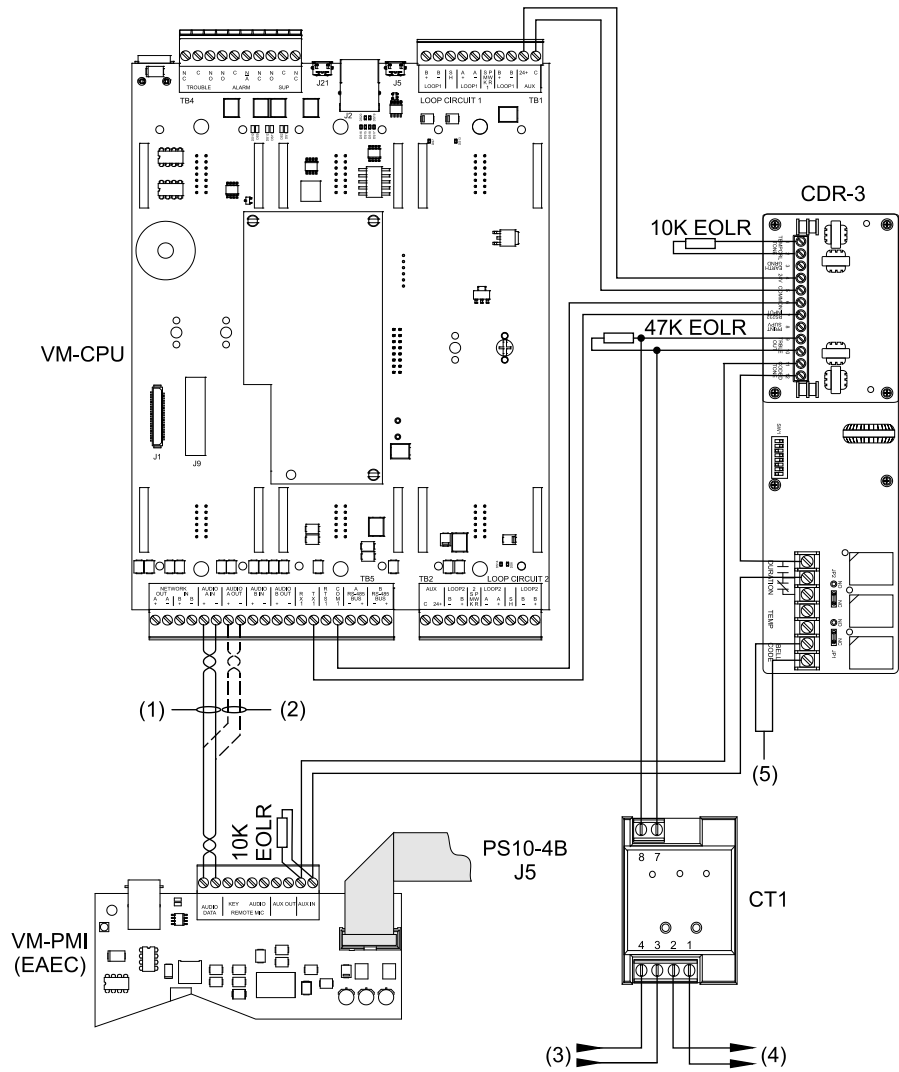

- (1) Network option card installed
- (2) Network option card not installed
- (3) From V-Series controller or previous device

- (4) To next device
- (5) For CDR-3 control of notification appliance circuits

Figure 35: Combined CDR-3 and IOP3A wiring for an MIR-PRT/S printer application

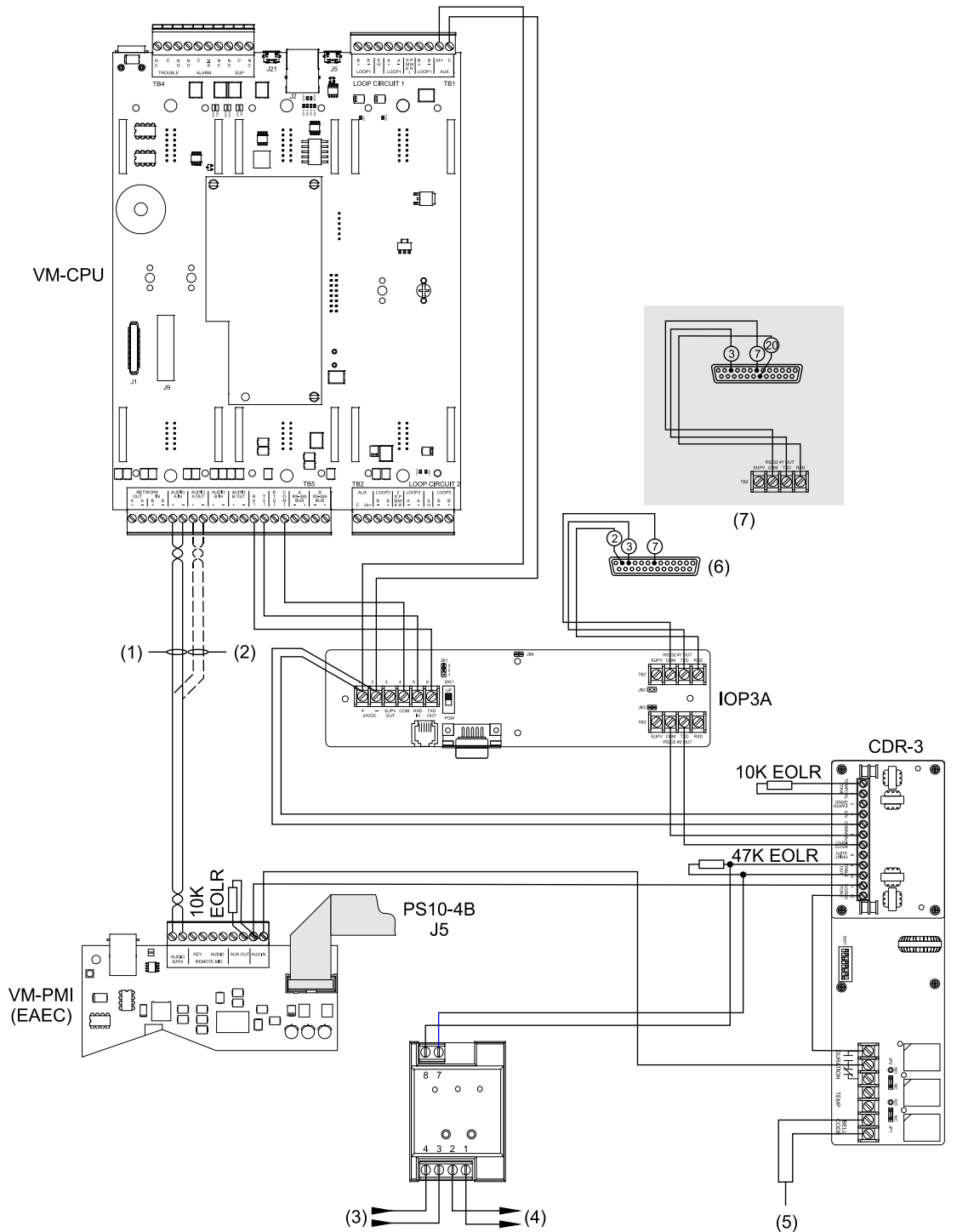

- (1) Network option card installed
- (2) Network option card not installed
- (3) From V-Series controller or previous device
- (4) To next device
- (5) For CDR-3 control of notification appliance circuits
- (6) DB-25 male connector to unsupervised MIR-PRT/S printer (front view)
- (7) DB-25 male connector to supervised MIR-PRT/S printer (front view)

## R-Series and K-R-Series annunciator DIP switch settings

For correct operation, the R-Series / K-R-Series remote annunciator must be configured with a unique address and must be in communication with the VM-1 fire alarm control panel. These settings are configured from the DIP Switch SW1 on the back of the annunciator (see Figure 36). Refer to Table 35 for descriptions of each Switch SW1 segment (switch). Refer to Table 36 on page 105 for examples of address settings.

For complete annunciator installation instructions, see the *R-Series Remote Annunciators and Expanders Installation and Operation Guide* (P/N 3100969-EN) or *K-R-Series Remote Annunciators and Expanders Installation and Operation Guide* (P/N 3102382-EN).

**Note:** DIP Switch SW1 segment 7 (SW1-7) *must* be set to On for annunciator communication with the VM-1 fire alarm control panel. In the On position, R-Series / K-R-Series remote annunciators and GCI(-NB) graph annunciators support Class B and Class A wiring, Style 6.

**Figure 36: R-Series / K-R-Series annunciator rear view showing DIP SW1 segments**

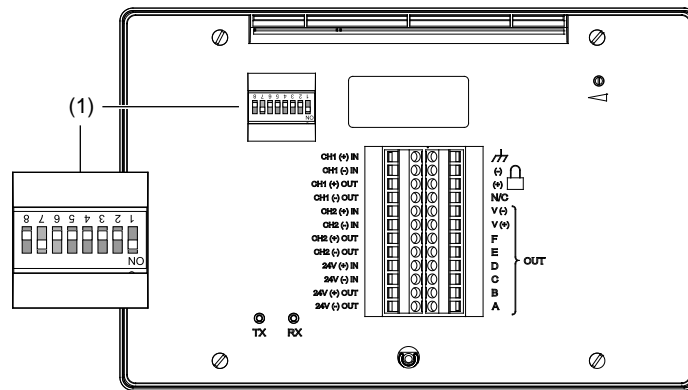

(1) DIP Switch SW1

**Table 35: DIP Switch SW1 settings**

Switch	Description
SW1-1 to SW1-5	Annunciator address.  The annunciator address (in binary). The factory setting is for address 2. See Table 36 for examples. Possible values are 1 to 31.
SW1-6	Baud rate.  OFF = 9600 baud (factory default setting) On = All other baud rates
SW1-7	Annunciator circuit type.  OFF = Circuit supports Class B and Redundant Class B wiring On = Circuit supports Class B and Class A wiring  <b>Note:</b> SW1-7 <i>must</i> be set to On.
SW1-8	Not used.

Table 36: Examples of DIP Switch SW1 address settings

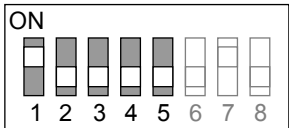
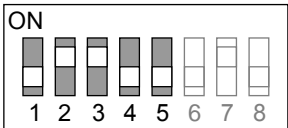
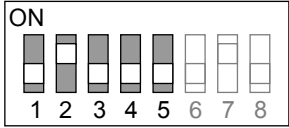
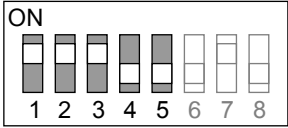
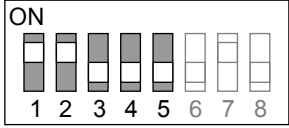
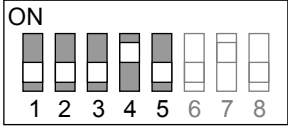
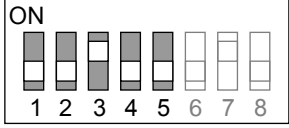
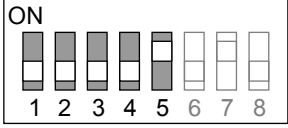
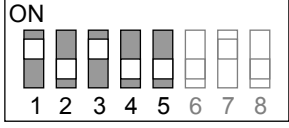
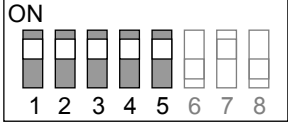
Address	Setting	Address	Setting
1		6	
2		7	
3		8	
4		16	
5		31	

## Runtime errors

Once all the cabinets have been defined, the devices labeled, and correlations written in the VM-CU the information is compiled. If the compiler finds no errors, the database is ready to be downloaded to the control panel. If an error occurs during the download process, it is referred to as a runtime error.

One source of runtime errors occurs during the initial database download. Until all portions of the database are downloaded into the VM-CPU memory, errors will be generated. Most of these errors will resolve themselves as the system progresses through download stages.

A second source of runtime errors can occur if there is a mismatch between the cabinet configuration in the VM-CU and the actual installed hardware. Common causes include a card address mismatch, card type mismatch, or even an entire cabinet mismatch.

A third source of runtime errors is primarily caused by communication problems between cabinets during the download. These can occur after the initial database has been downloaded into all cabinets and subsequent downloads are performed using the network data circuit.

The table below lists some error messages that may appear on the LCD screen during the database download and their possible causes.

**Note:** Refer to Chapter 7 “Service and troubleshooting” on page 123 for issues other than those listed below that may arise during panel operation.

**Table 37: Runtime errors caused by the database download**

<b>Error message</b>	<b>Possible cause</b>
Unable to perform operation	The control panel needs restarted
Busy signal	The system is busy; wait, and then retry
Size parameter trouble	Check the download connections and VM-CU settings, and then retry the download
Checksum error in packet	Check the download connections and VM-CU settings, and then retry the download
Device type error	A conflict exists between the VM-CU download setting and the device type; check the configuration
Parcel #	Check the download connections and VM-CU settings, and then retry the download
Inaccessible panel	The VM-CU cannot see the panel; check the network wiring
Session in progress	The system is busy; wait, and then retry the download
Erase program trouble	Check the download connections and VM-CU settings, and then retry the download
Block number	Check the download connections and VM-CU settings, and then retry the download
Version mismatch	The downloaded firmware does not agree with the version setting; correct the mismatch

# Chapter 6

## Preventive maintenance and testing

### Summary

This chapter provides instruction for maintaining and testing the VM-1 life safety system.

### Content

Visual inspections 108

Routine maintenance and tests 109

    Required tools and materials 109

    V-Series device maintenance tips 109

    Replacing a V-Series detector optical chamber 110

    Detector cleaning procedures 111

    Detector component replacement procedures 113

    Maintenance schedule 113

System trouble and maintenance log 121

Record of completion 122

## Visual inspections

Perform visual inspections in accordance with Table 38 or more often if required by the local AHJ. See Table 40 on page 114 for test methods.

**Table 38: Visual inspection schedule**

Component	Frequency	Recommended procedure
Radiant energy fire detectors	Monthly	Inspect the equipment for any visible signs of damage or other changes that may adversely affect performance. Clean if necessary.
Supervisory signal devices	Monthly	Verify that the module's green LED flashes. Ensure there are no changes that may adversely affect equipment performance.
Waterflow devices	Monthly	Verify that the module's green LED flashes. Ensure there are no changes that may adversely affect equipment performance.
Batteries	Semiannually	Inspect batteries for corrosion or leakage. Verify that the battery connections are tight and secure. Clean the connections, if required. Replace batteries every 5 years, or sooner if conditions warrant.
Control unit trouble signals	Semiannually	Ensure there are no changes that may adversely affect equipment performance.
Emergency voice/alarm communication equipment	Semiannually	Inspect the equipment for any visible signs of damage or other changes that may adversely affect performance.
Remote annunciators	Semiannually	Inspect the equipment for any visible signs of damage or other changes that may adversely affect performance.
Duct detectors	Semiannually	Inspect the equipment for any visible signs of damage or other changes that may adversely affect performance.
Electromechanical releasing devices	Semiannually	Ensure there are no changes that may adversely affect equipment performance.
Fire extinguishing systems or suppression systems	Semiannually	Ensure there are no changes that may adversely affect equipment performance.
Fire alarm boxes	Semiannually	Inspect the equipment for any visible signs of damage or other changes that may adversely affect performance.
Heat detectors	Semiannually	Inspect the equipment for any visible signs of damage or other changes that may adversely affect performance. Clean if necessary.
Smoke detectors	Semiannually	Inspect the equipment for any visible signs of damage or other changes that may adversely affect performance. Clean if necessary.
Interface equipment	Semiannually	Inspect the equipment for any visible signs of damage or other changes that may adversely affect performance.
Alarm notification appliances	Semiannually	Verify that the module's green LED flashes. Ensure there are no changes that may adversely affect equipment performance.

Component	Frequency	Recommended procedure
Supervising station fire alarm system transmitters	Semiannually	Ensure there are no changes that may adversely affect equipment performance.
Control unit	Annually	Inspect the equipment for any visible signs of damage or other changes that may adversely affect performance.
Fiber optic cable connections	Annually	Inspect the cables for any visible signs of damage, loose connections, or other changes that may adversely affect performance

## Routine maintenance and tests

Perform routine maintenance and tests in accordance with Table 39 on page 113 or more often if required by the local AHJ. See Table 40 on page 114 for test methods.

### Notes

- Before starting testing, notify all areas where the alarm sounds and off premises locations that receive alarm and trouble transmissions that testing is in progress.
- Keep records of all testing and maintenance on the protected premises for a period of at least five (5) years.
- A complete check of installed field wiring and devices should be made at regular intervals, in accordance with NFPA 72 and ULC-524 requirements. This includes testing all alarm and supervisory alarm initiating devices and circuits, and any off premise connections.
- Panel operation should be verified in the alarm, supervisory, and trouble modes.

## Required tools and materials

- Slotted screwdriver, insulated
- Digital multimeter
- 1.1 k $\Omega$ , 1 W resistor
- 12-inch (30.5 cm) jumper lead with alligator clips
- Commercial grade (1200 to 1500 W) hair blower (for testing heat detectors)
- Conventional vacuum cleaner (for cleaning GSA detectors)
- GSA Service Tool Kit (P/N GSA-ST) (for cleaning GSA detectors)
- V-Series smoke detector replacement optical chamber (P/N 211-10PKG)
- Control panel door key
- System passwords (if any)

## V-Series device maintenance tips

### Detectors

When removing one detector at a time, wait 1-minute after replacing the first detector before removing the next detector. This gives the system time to recognize and remap the first detector before generating a trouble condition caused by removing the second detector.

To determine the months until end-of-life, run a maintenance report from the control panel. See “Device maintenance reports” on page 41.

### CO maintenance alert

In addition to displaying a maintenance alert when the photo element dirtiness is at or above 80%, the loop controller also displays a maintenance alert when the CO sensor module is at or below 6 months until end-of-life. If both elements reach or pass these thresholds, there is only one maintenance alert.

Once the dirtiness threshold is at 100%, a dirty detector trouble displays for the photo element. Once there are zero months until end-of-life, the panel displays the CO end-of-life trouble message.

### CO maintenance trouble

The CO sensor module has a life span of 6 years. After 6 years, the detector sends out an end-of-life trouble message. When the message is transmitted, replace the CO sensor module.

To determine the months until end-of-life, run a maintenance report from the LCD screen. See “Device maintenance reports” on page 41.

### Modules

Visually inspect the modules to ensure the physical installation is secure. Perform functional testing of the module regularly as required by the AHJ.

## Replacing a V-Series detector optical chamber

1. Remove the detector from the base.
2. Insert a screwdriver in the small slot on the detector cap. See Figure 37 below.
3. Pry the cap off the detector body.
4. Squeeze the two arrows labeled “squeeze here,” on the optical block chamber, and the pull off the chamber.
5. Blow off the optical block base using clean compressed air.
6. Snap a new optical block chamber in place. Make sure you line up the two arrows on the block chamber with the snaps on the optical block base.
7. Connect the detector cap to the detector body by rotating the cap clockwise until it snaps into position.
8. Install the detector onto the base.
9. Test the detector and verify sensitivity.

Figure 37: V-Series detector optical chamber

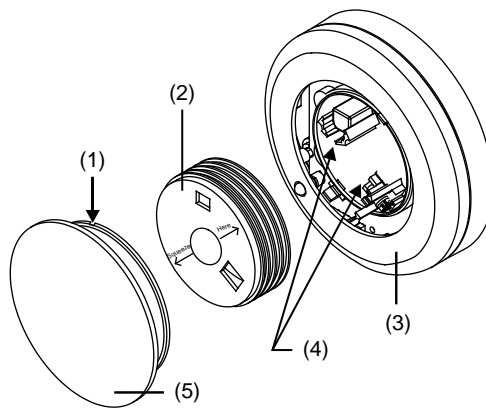

- (1) Screwdriver slot
- (2) Optical block chamber
- (3) Detector body

- (4) Optical block base
- (5) Detector cap

## Detector cleaning procedures

There are two cleaning procedures: one for GSA detectors and one for V-PCOS detectors.

**Note:** In order to avoid false alarms, disable the detector being cleaned before cleaning.

### Cleaning GSA detectors

Cleaning GSA detectors requires a conventional vacuum cleaner equipped with the detector-cleaning tool from the GSA Service Tool Kit (P/N GSA-ST). The tool is installed on the end of the suction hose (nominal 1.5 in. (3.8 cm) ID). This creates a high velocity vortex scrubbing action around the detector to remove loose dust and debris.

Without using the detector-cleaning tool, it is not possible to verify the dirtiness levels after cleaning. If the cleaning tool is not used, clean the detector per instructions below, operate the detectors for a minimum of two hours, and then restart the loop controller. If the detectors are cleaned properly, the maintenance indicators return to normal condition.

#### To clean GSA detectors:

1. Disable the detector to prevent false alarms (see “Disabling and enabling devices” on page 43).
2. Use a conventional vacuum cleaner brush attachment to remove any visible dirt and debris from the immediate area of the detector.
3. Connect the detector-cleaning tool to the vacuum hose. See Figure 38 below.
4. Place the detector-cleaning tool over the detector head for approximately 10 seconds.
5. After the detector has been cleaned, restore it to proper operation (see “Disabling and enabling devices” on page 43).
6. Run the detector sensitivity report to print a list of detector sensitivity and compensation readings, and to verify the effectiveness of the cleaning.

**Figure 38: Using the GSA detector-cleaning tool**

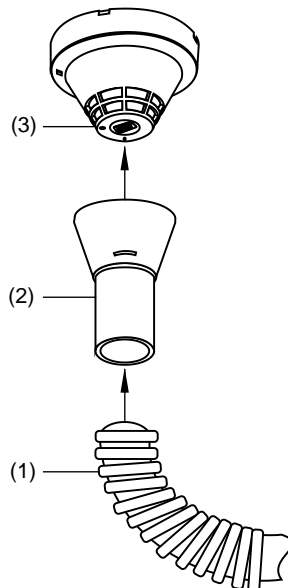

- (1) Vacuum hose
- (2) Detector cleaning tool
- (3) Detector head

### Cleaning V-PCOS detectors

Cleaning the V-PCOS detector requires opening the detector and cleaning the interior using a vacuum cleaner and a soft brush.

#### To clean V-PCOS detectors:

1. Disable the detector to prevent false alarms (see “Disabling and enabling devices” on page 43).
2. Use a conventional vacuum cleaner brush to remove visible dirt and debris from the immediate area of the detector.
3. Remove the detector from the detector base by inserting a small screwdriver into the tamper-resist access slot while rotating the detector counterclockwise. See Figure 39 on page 112.
4. Push the locking tab on the bottom of the detector toward the center, and then twist and pull to remove the cover.
5. Using a soft brush and vacuum, carefully remove any dust and dirt from around the sensor chambers.
6. After the detector has been cleaned, reassemble and restore it to proper operation (see “Disabling and enabling devices” on page 43).
7. Operate the detector for a minimum of two hours, and then restart the loop controller. When cleaned properly, the maintenance indicators return to normal condition.
8. Check and record the detector’s dirty level reading to verify the effectiveness of cleaning. See “Device maintenance reports” on page 41.
9. If cleaning is unsuccessful, return the detector to the factory and replace it with a new detector.

**Figure 39: Cleaning a V-PCOS detector**

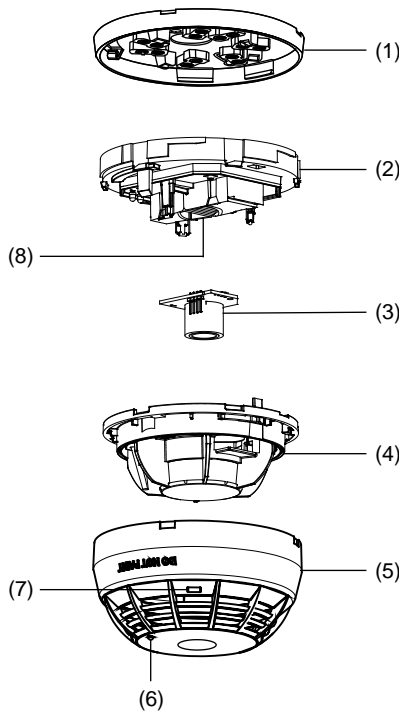

- (1) Mounting base
- (2) Detector base
- (3) CO sensor module
- (4) Smoke chamber

- (5) Detector cover
- (6) LED indicator
- (7) Access slot for tamper-resist mechanism
- (8) Optics box

## Detector component replacement procedures

### V-PCOS smoke chamber

V-PCOS smoke detectors have a replaceable smoke chamber. Replace the chamber with model number 2-SPRC2 if the control panel still indicates a dirty detector after cleaning the detector. Refer to the *2-SPRC2 Smoke Chamber Replacement Installation Sheet* (P/N 3101596) for instructions.

### CO sensor module

CO detectors use a 2-CORPL replacement sensor. Replace the sensor every six years from the date of manufacture or when the control panel indicates a sensor end-of-life condition, whichever comes first. Refer to the *2-CORPL CO Replacement Module Installation Sheet* (P/N 3101589) for instructions.

**Note:** For proper operation, never replace the CO sensor without also replacing the PCB because each board has calibration data specific to the matching CO sensor.

## Maintenance schedule

**Table 39: Routine maintenance schedule**

Component	Frequency
Control equipment [1]	Quarterly/Annually
Supervisory signal devices (except valve tamper switches)	Quarterly
Off-premises transmission equipment	Quarterly
Waterflow devices	Semiannually
Valve tamper switches	Semiannually
Batteries [2]	Annually
Control unit trouble signals	Annually
Fiber optic cable connections	Annually
Emergency voice/alarm communication equipment	Annually
Remote annunciators	Annually
Smoke detectors	Annually
Heat detectors	Annually
Fire alarm boxes	Annually
Fire extinguishing systems or suppression systems	Annually
Guard tour equipment	Annually
Interface equipment	Annually
Audible notification appliances	Annually
Textual audible notification appliances (speakers)	Annually
Visible notification appliances	Annually
Supervising station fire alarm system transmitters	Annually

[1] Test control equipment quarterly when it is not connected to a supervising station.

[2] Replace batteries every five years or sooner if conditions warrant.

**Table 40: Routine maintenance and tests**

<b>Component</b>	<b>Test</b>	<b>Test methods</b>
Control panel	Visual inspection	Inspect the equipment for any visible signs of damage or other changes that may Adversely affect performance.
	Initial and Reacceptance	<ol style="list-style-type: none"> <li>1. Verify that the control panel indicates open, short, and ground faults for all notification appliance circuits, initiating device circuits, and signaling line circuits.</li> <li>2. Verify that the control panel activates all evacuation signals and auxiliary functions according to the site-specific software.</li> <li>3. Verify that all controls and indicators are working.</li> <li>4. Disconnect the primary (mains) power. Verify that the control unit indicates an AC power failure.</li> </ol>
	Quarterly/Annual	Test the one-fourth of the entire system every three months such that the entire system is tested in a one year period, or test the entire system once each year.
Standby batteries	Visual inspection	Inspect batteries for corrosion or leakage. Verify that the battery connections are tight and secure. Clean the connections, if required. Replace batteries every five years or sooner if conditions warrant.
	Initial and Reacceptance	<ol style="list-style-type: none"> <li>1. With the control panel powered up, and with the batteries connected and fully charged, verify the voltage across the battery terminals is the correct voltage in accordance with the battery manufacturer's specifications.</li> <li>2. With the control panel under full load, disconnect the primary (mains) power. Wait until the standby operation time requirement passes then activate all alarm signals. Verify that the alarm signals remain active for at least 5 minutes for horns and strobes or 15 minutes for audio in the USA, whichever is greater.</li> </ol>
	Annual	<ol style="list-style-type: none"> <li>1. With the control panel powered up, and with the batteries connected and fully charged, verify that the voltage across the battery terminals is the correct voltage in accordance with the battery manufacturer's specifications.</li> <li>2. Test the capacity of the batteries using a battery tester suitable for the amp-hour rating of the batteries.</li> </ol>

Component	Test	Test methods
Remote annunciators	Visual inspection	Inspect the equipment for any visible signs of damage or other changes that may adversely affect performance.
	Initial and Reacceptance	<ol style="list-style-type: none"> <li>1. Verify that the remote annunciator indicates open, short, and ground faults while testing the panel.</li> <li>2. Verify that all controls and indicators are working.</li> <li>3. If LEDs are configured, verify the indicators by activating the points correlated to the LED.</li> <li>4. Disconnect the RS-485 line and verify that a trouble message is displayed on both the panel and the remote annunciator.</li> </ol>
Smoke detectors	Visual inspection	<ol style="list-style-type: none"> <li>1. Verify that the detector's green LED flashes.</li> <li>2. Inspect the equipment for any visible signs of damage or other changes that may adversely affect performance. Clean if necessary.</li> </ol>
	Initial and Reacceptance	<ol style="list-style-type: none"> <li>1. Remove the detector from its base. Verify that the control panel displays a trouble message that correctly identifies the detector.</li> <li>2. Activate the detector. Verify that the detector's red LED flashes and the control panel displays an alarm message that correctly identifies the detector.</li> <li>3. If the detector is installed in a relay base, verify the correct operation of the relay.</li> <li>4. Run a Device Maintenance Report on all the smoke detectors in the system. Verify that all sensitivity levels fall within acceptable limits. Keep a printed copy for your records.</li> </ol>
	Annual	<ol style="list-style-type: none"> <li>1. Activate the detector. Verify that the detector's red LED flashes and the control panel displays an alarm message that correctly identifies the detector.</li> <li>2. If the detector is installed in a relay base, verify the correct operation of the relay.</li> <li>3. Run a Device Maintenance Report on all the smoke detectors in the system. Verify that all sensitivity levels fall within acceptable limits. Keep a printed copy for your records.</li> </ol>

Component	Test	Test methods
Heat detectors	Visual inspection	<ol style="list-style-type: none"> <li>1. Verify that the detector's green LED flashes.</li> <li>2. Inspect the equipment for any visible signs of damage or other changes that may adversely affect performance. Clean if necessary.</li> </ol>
	Initial and Reacceptance	<p><b>Caution:</b> Directing heated air at a single point may permanently damage the heat detector. Wave the hair blower slowly back and forth approximately 1 in. from the heat entry slots.</p> <ol style="list-style-type: none"> <li>1. Remove the detector from its base. Verify that the control panel displays a trouble message that correctly identifies the detector.</li> <li>2. Activate the detector using a commercial grade (1200 to 1500 W) hair blower. Verify that the detector's red LED flashes and the control panel displays an alarm message that correctly identifies the detector.</li> <li>3. If the detector is installed in a relay base, verify the correct operation of the relay.</li> </ol>
	Annual	<p><b>Caution:</b> Directing heated air at a single point may permanently damage the heat detector. Wave the hair blower slowly back and forth approximately 1 in. from the heat entry slots.</p> <ol style="list-style-type: none"> <li>1. Activate the detector using a commercial grade (1200 to 1500 W) hair blower. Verify that the detector's red LED flashes and the control panel displays an alarm message that correctly identifies the detector.</li> <li>2. If the detector is installed in a relay base, verify the correct operation of the relay.</li> </ol>
Duct detectors	Visual inspection	Inspect the equipment for any visible signs of damage or other changes that may adversely affect performance.
	Initial and Reacceptance	Activate the equipment. Make sure the control panel correctly identifies the device.
	Semiannual	Activate the equipment. Make sure the control panel correctly identifies the device.
Fire alarm boxes	Visual inspection	Inspect the equipment for any visible signs of damage or other changes that may adversely affect performance.
	Initial and Reacceptance	Activate the equipment. Make sure the control panel correctly identifies the device.
	Semiannual	Activate the equipment. Make sure the control panel correctly identifies the device.

Component	Test	Test methods
Alarm input modules (except waterflow switch inputs)	Visual inspection	Verify that the module's green LED flashes. Ensure there are no changes that may adversely affect equipment performance.
	Initial and Reacceptance	<ol style="list-style-type: none"> <li>1. Open the circuit. Verify that the control panel displays a trouble message that correctly identifies the module.</li> <li>2. Short each side of the circuit to ground one at a time. Verify that for each short the control panel displays a ground fault message that correctly identifies the module.</li> <li>3. Activate the module. Verify that the module's red LED flashes and the control panel displays an alarm message that correctly identifies the module.</li> </ol>
	Annual	Activate the module. Verify that the red LED flashes and the control panel displays an alarm message that correctly identifies the module.
Waterflow switch input modules	Visual inspection	Verify that the module's green LED flashes. Ensure there are no changes that may adversely affect equipment performance.
	Initial and Reacceptance	<ol style="list-style-type: none"> <li>1. Open the circuit. Verify that the control panel displays a trouble message that correctly identifies the module.</li> <li>2. Short each side of the circuit to ground one at a time. Verify that for each short the control panel displays a ground fault message that correctly identifies the module.</li> <li>3. Activate the module. Verify that the module's red LED flashes and the control panel displays an alarm message that correctly identifies the module.</li> </ol>
	Semiannual	Activate the module. Verify that the module's red LED flashes and the control panel displays an alarm message that correctly identifies the module.
Supervisory input modules (except valve tamper inputs)	Visual inspection	Verify that the module's green LED flashes. Ensure there are no changes that may adversely affect equipment performance.
	Initial and Reacceptance	<ol style="list-style-type: none"> <li>1. Open the circuit. Verify that the control panel displays a trouble message that correctly identifies the module.</li> <li>2. Short each side of the circuit to ground one at a time. Verify that for each short the control panel displays a ground fault message that correctly identifies the module.</li> <li>3. Activate the module. Verify that the module's red LED flashes and the control panel displays a supervisory message that correctly identifies the module.</li> </ol>
	Quarterly	Activate the module. Verify that the module's red LED flashes and the control panel displays a supervisory message that correctly identifies the module.
Valve tamper input modules	Visual inspection	Verify that the module's green LED flashes. Ensure there are no changes that may adversely affect equipment performance.

Component	Test	Test methods
	Initial and Reacceptance	<ol style="list-style-type: none"> <li>1. Open the circuit. Verify that the control panel displays a trouble message that correctly identifies the module.</li> <li>2. Short each side of the circuit to ground one at a time. Verify that for each short the control panel displays a ground fault message that correctly identifies the module.</li> <li>3. Activate the module. Verify that the module's red LED flashes and the control panel displays a supervisory message that correctly identifies the module.</li> </ol>
	Semi-annual	Activate the module. Verify that the module's red LED flashes and the control panel displays a supervisory message that correctly identifies the module.
Releasing modules	Visual inspection	Verify that DS2 flashes and DS4 is on. Ensure there are no changes that may adversely affect equipment performance.
	Initial and Reacceptance	<p><b>WARNING:</b> Disconnect all wiring on TB4 (RELEASE 1 and RELEASE 2) when servicing or testing the system. Disabling points does not prevent activation of the release circuits. Failure to follow these instructions may result in loss of life, serious injury, or property damage.</p> <ol style="list-style-type: none"> <li>1. Verify that the control panel indicates open, shorts, and ground faults for each of the circuits.</li> <li>2. Verify that the release initiation circuit activates the release circuits as intended, and that all required signals are indicated on the panel.</li> <li>3. Verify that the manual release switch, if used, activates the release circuits as intended, and that all required signals are indicated on the control panel.</li> <li>4. Verify that the abort switch, if used, prevents the release circuits from activating as intended.</li> </ol>
	Semiannual	<p><b>WARNING:</b> Disconnect all wiring on TB4 (RELEASE 1 and RELEASE 2) when servicing or testing the system. Disabling points does not prevent activation of the release circuits. Failure to follow these instructions may result in loss of life, serious injury, or property damage.</p> <ol style="list-style-type: none"> <li>1. Verify that the release initiation circuit activates the release circuits as intended, and that all required signals are indicated on the control panel.</li> <li>2. Verify that the manual release switch, if used, activates the release circuits as intended, and that all required signals are indicated on the control panel.</li> <li>3. Verify that the abort switch, if used, prevents the release circuits from activating as intended.</li> </ol>
Audible notification appliances	Visual inspection	Ensure there are no changes that may adversely affect equipment performance.

Component	Test	Test methods
	Initial and Reacceptance	Using a sound level meter meeting ANSI S1.4a Type 2 requirements, measure and record the maximum output of each appliance when the audible emergency evacuation signal is on. Set the sound level meter in accordance with ANSI S3.41 and use the time-weighted characteristic F (FAST).
	Annual	Using a sound level meter meeting ANSI S1.4a Type 2 requirements, measure and record the maximum output of each appliance when the audible emergency evacuation signal is on. Set the sound level meter in accordance with ANSI S3.41 and use the time-weighted characteristic F (FAST).
Textual audible notification appliances (speakers)	Visual inspection	Ensure there are no changes that may adversely affect equipment performance.
	Initial and Reacceptance	Using a sound level meter meeting ANSI S1.4a Type 2 requirements, measure and record the maximum output of each appliance when the audible emergency evacuation signal is on. Set the sound level meter in accordance with ANSI S3.41 and use the time-weighted characteristic F (FAST).  Verify that audible information is distinguishable and understandable.
	Annual	Using a sound level meter meeting ANSI S1.4a Type 2 requirements, measure and record the maximum output of each appliance when the audible emergency evacuation signal is on. Set the sound level meter in accordance with ANSI S3.41 and use the time-weighted characteristic F (FAST).  Verify that audible information is distinguishable and understandable.
Visible notification appliances	Visual inspection	Ensure there are no changes that may adversely affect equipment performance.
	Initial and Reacceptance	Verify that the appliance locations are in accordance with the approved layout and are set for the correct candela rating.  Verify that each appliance flashes.
	Annual	Verify that each appliance flashes.
Off-premises transmission equipment	Visual inspection	Ensure there are no changes that may adversely affect equipment performance.
	Initial and Reacceptance	<ol style="list-style-type: none"> <li>1. Activate an alarm initiating device. Verify that the off-premises location receives an alarm signal.</li> <li>2. Create a trouble condition. Verify that the off-premises location receives a trouble signal.</li> <li>3. Activate a supervisory device. Verify that the off-premises location receives a supervisory signal.</li> </ol>

Component	Test	Test methods
Digital alarm communicator transmitter (DACT)	Semiannual	<p>4. If the module is configured to transmit alarm signals and trouble signals over the same dedicated pair of wires, create a trouble condition, and then activate an alarm initiating device. Verify that the off-premises location receives an alarm signal and a trouble signal.</p> <hr/> <p>1. Activate an alarm initiating device. Verify that the off-premises location receives an alarm signal.</p> <p>2. Create a trouble condition. Verify that the off-premises location receives a trouble signal.</p> <p>3. Activate a supervisory device. Verify that the off-premises location receives a supervisory signal.</p> <p>4. If the module is configured to transmit alarm signals and trouble signals over the same dedicated pair of wires, create a trouble condition, and then activate an alarm initiating device. Verify that the off-premises location receives an alarm signal and a trouble signal.</p>
	Visual inspection	Inspect the equipment for any visible signs of damage or other changes that may adversely affect performance.
	Initial and Reacceptance	<p>1. Activate an alarm input while using the primary telephone line for a telephone call.</p> <ul style="list-style-type: none"> <li>• Verify that the supervising station receives the correct signal.</li> <li>• Verify completion of the transmission attempt occurs within 90 seconds.</li> </ul> <p>2. Disconnect the primary telephone line and connect the secondary telephone line.</p> <ul style="list-style-type: none"> <li>• Verify that the control panel indicates a DACT trouble message.</li> <li>• Verify that the DACT transmits the trouble signal to the supervising station within 4 minutes of detecting the fault.</li> </ul> <p>3. Disconnect the secondary telephone line and connect the primary telephone line.</p> <ul style="list-style-type: none"> <li>• Verify that the control panel indicates a DACT trouble message.</li> <li>• Verify that the DACT transmits the trouble signal to the supervising station within 4 minutes of detecting the fault.</li> </ul>
Semiannual	Same as initial and reacceptance testing.	



## Record of completion

NFPA 72 requires a Record of Completion be filled out at the time of system acceptance and approval, and revised when changes to the system are made. You can download a copy of the form from the NFPA website ([www.nfpa.org](http://www.nfpa.org)).

After completing the Record of Completion form, mount it near the fire alarm panel or give it to the building representative.

# Chapter 7

## Service and troubleshooting

### Summary

This chapter provides instructions for servicing and troubleshooting the fire alarm system. It is intended for those trained and authorized to maintain the system.

### Content

- System repairs 124
- Precautions 124
  - Removing or replacing circuit board modules 124
  - Handling static sensitive circuit board modules 125
- Panel restart problems 125
- Hardware troubleshooting 125
  - PS10-4B Power Supply troubleshooting 125
  - VM-CPU Main Board troubleshooting 126
  - VM-NOCF Fiber Network Option module troubleshooting 129
  - D12LS-VM control-indicating modules troubleshooting 130
  - VM-DACT Dual Line Dialer Card troubleshooting 131
  - VM-PMI Paging Microphone Interface troubleshooting 133
- Pseudo points 134
- Understanding VM signaling line circuits 146
  - Operation 146
  - Signaling line circuit troubleshooting basics 147
  - Substituting devices 151
  - Substituting loop controllers 155
- Loop controller troubleshooting 155
  - Mapping errors 156
- Using the Configuration Utility diagnostics tools 157
  - Loop controller diagnostics sequence 157
  - Mapping errors diagnostics 158
  - Device chain diagnostics 159
  - Message counters diagnostics 160
  - Device troubles diagnostics 160
  - Trouble Tables diagnostics 163
  - Signaling line circuit real-time statuses 163
- Using HyperTerminal to troubleshoot the system 164
  - Setting up a HyperTerminal connection 164

## System repairs

The VM-1 life safety system is made up of modular assemblies that are easily installed and maintained. Because of the modular design, component level field repairs mainly consist of isolating a fault to the circuit card in an assembly and replacing the defective card.

The following table provides a general guideline of recommended spare components to have on hand.

**Table 41: Recommended spares list**

Minimum of 1 each or 10% of the quantity installed	Minimum of 3 each or 10% of the quantity installed
<ul style="list-style-type: none"> <li>• Power supply</li> <li>• Option cards</li> <li>• Amplifiers (if no backup installed in system)</li> <li>• Printer ribbon</li> </ul>	<ul style="list-style-type: none"> <li>• Monitor modules</li> <li>• Control modules</li> <li>• Heat detectors</li> <li>• Ionization smoke detectors</li> <li>• Photoelectric smoke detectors</li> <li>• Detector base</li> <li>• Duct detector filter kits</li> <li>• Breakglass replacement for pull stations</li> <li>• Breakglass replacement for warden stations</li> <li>• Horn, bell, strobe, and speaker</li> </ul>

Service and repair of system components centers around the following assumptions:

- Qualified technicians possessing a complete understanding of the system hardware and functions will perform maintenance.
- Only certified maintenance technicians will service the equipment.
- Maintenance technicians will have a readily available supply of replacement parts.

## Precautions

### Removing or replacing circuit board modules

When removing or replacing circuit modules, always remember to:

- First disconnect the battery then remove AC power from the control panel. Removing or replacing circuit modules when power is applied will damage the equipment.
- Avoid applying excessive force to the snap-rivet fasteners that lock the plug-in modules in place. If needed, use the extraction tool provided in the hardware kit.

## Handling static sensitive circuit board modules

Many of the panel components are circuit boards that are sensitive to electrostatic discharge. To avoid damage to the board, take the following precautions:

- Use only approved grounding straps that are equipped with a 1 M $\Omega$  resistive path to earth ground.
- Remove a circuit board module from its protective antistatic packaging only for inspection or installation.
- Always hold circuit modules by the sides. Avoid touching component leads and connector pins.

## Panel restart problems

The VM-1 system is designed to test its database integrity and its configured hardware at startup. When a new CPU database is downloaded to a panel, the panel restarts and validates the database. If a database error is detected, the panel will attempt to restart, and in some cases the panel continually restarts. If your panel continually restarts, recycle the panel several times as described below to restore the system to its normal state.

### To restore the system:

1. Disconnect battery wiring from the power supply.
2. Apply AC power to the panel and wait until the buzzer sounds.
3. Cycle the AC power five times by removing the power for 10 seconds, and then reapplying the power for 10 seconds.

After the fifth recycle, the LCD should display “Panel Service Utility ... waiting for SDU download.”

4. Using an RS-232 RJ-11 standard cable, connect the VM-CPU in the panel to the computer that has your VM-CU project database. See “RS-232 download” on page 53.
5. Open the VM-CU project and compile the rules.
6. Run a database conversion, and then download the database to the panel.
7. Disconnect the RJ-11 connection, and then reconnect the battery wiring to the power supply.

**Note:** The panel will restore to normal state if there are no discrepancies between the database and installed equipment, and all hardware is functioning correctly.

## Hardware troubleshooting

### PS10-4B Power Supply troubleshooting

Under most conditions, a defective power supply will be identified by the system, and annunciated as a trouble. The system may continue to operate nearly normally, as the battery connected to the faulty supply will automatically be switched into the circuit, as the load demands.

You can connect the panel to the PC running the VM-CU and perform a power supply diagnostics check. See the VM-CU diagnostics help topic for details.

**Table 42: Voltage specifications**

Test Point	Voltage
NAC output current	
Regulated	3.0 A max. per circuit 6.0 A total, shared
Special application	3.0 A max. per circuit 9.0 A total, shared
AUX output current	6.0 A total, shared
Input AC voltage	94 to 264 VAC, 50/60 Hz
Battery charging current	1.5 or 3 A, selectable

**Table 43: Power Supply troubleshooting**

Problem	Possible cause
Auxiliary voltage low (< 20 V)	<ul style="list-style-type: none"> <li>• There is an excessive load</li> </ul>
Batteries will not charge	<ul style="list-style-type: none"> <li>• The system is in alarm mode</li> <li>• The NAC/AUX outputs on the power supply are configured for “AUX” and are loaded to more than 6.0 A</li> <li>• A wrong battery type is configured in the VM-CU</li> <li>• The battery shorted</li> <li>• The battery is not wired correctly to the PS10-4B</li> </ul>
System will not operate on batteries	<ul style="list-style-type: none"> <li>• The battery voltage is low (system automatically turns off when batteries too low to properly operate system)</li> <li>• The batteries were connected before AC power was energized</li> <li>• The batteries are defective</li> </ul>

## VM-CPU Main Board troubleshooting

The VM-CPU controls all the communication and processing of information for modules located in its cabinet. VM-1 life safety network communication between VM-CPU modules in other cabinets is also processed by the VM-CPU.

Network communication is RS-485 when a VM-NOC option card is installed in the VM-CPU or fiber optic when the VM-NOCF Fiber Network Option Module is installed.

The VM-CPU main board provides several LEDs that indicate activity on a communication path. See Figure 40 on page 127 for the LED locations on the main board and Table 44 on page 127 for LED descriptions.

**Note:** If a VM-CPU is defective, the entire VM-ELEC must be replaced.

Figure 40: VM-CPU LEDs

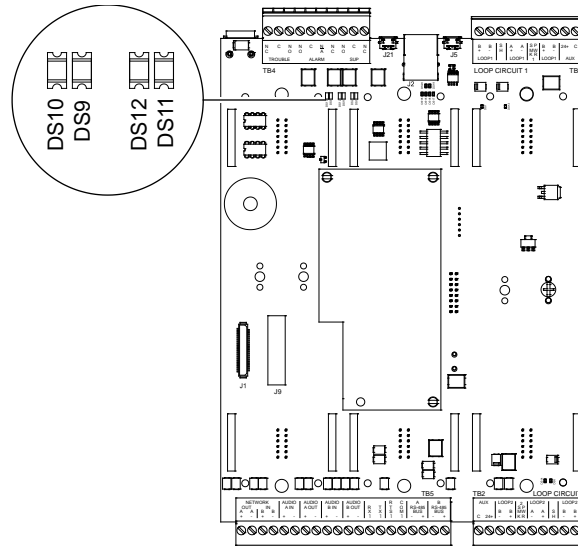

Table 44: VM-CPU LED descriptions

LED	Normal state	Descriptions
DS9	Flashing	Network data RX Class B activity
DS10	Flashing	Network data TX Class B activity
DS11	Flashing	Network data RX Class A activity
DS12	Flashing	Network data TX Class A activity

### Network data and digital audio risers

LEDs DS9, DS10, DS11, and DS12 in Figure 40 above show the location and normal state of the network communication status LEDs on the VM-CPU.

Network wiring alternates between channel A and channel B, as shown in Figure 41.

**Figure 41: Network wiring alternating between channel A and B**

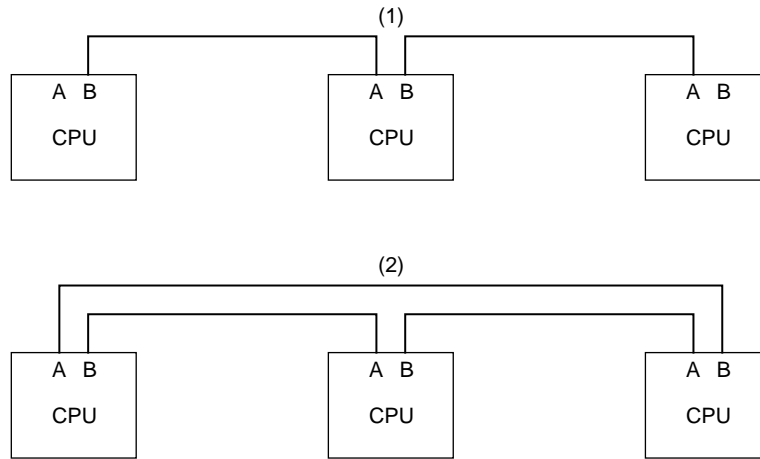

- (1) Class B network wiring one-line diagram
- (2) Class A or Class X network wiring one-line diagram

When multiple VM-CPU modules are networked together using Class B wiring, the network data LEDs should flash on all panels except the first and last panels. This indicates normal two-way network communication activity on both data channels.

When multiple VM-CPU modules are networked together using Class A or Class X wiring, the network data LEDs should flash continuously. This indicates normal two way network communication activity on data channels A and B.

The data network and digital audio risers are isolated at each VM-CPU. This prevents a shorted data circuit from interrupting communication on the entire circuit.

When trying to isolate trouble on a data network or digital audio riser, remember that both shorted and open circuit segments will interrupt communication between two VM-CPU modules. In this case, the VM-1 life safety network will reconfigure and operate as two independent sub-networks

Due to the isolation between cabinets, during a ground fault condition the number of potential circuits to be investigated is limited to those originating from a single cabinet.

**Table 45: VM-CPU Main Board troubleshooting**

Problem	Possible cause
LEDs DS9 (RX) and DS10 (TX) or DS11 (RX) and DS12 (TX) off, or both pairs off	<ul style="list-style-type: none"> <li>• The TB5 network wiring + and – is reversed</li> <li>• A circuit was not properly terminated</li> <li>• The network A and B circuits are crossed</li> <li>• An improper wire was used</li> <li>• A ground fault has been detected</li> <li>• The VM-NOC card is not seated properly</li> </ul>
Peripheral RS-232 device wired to TB5 inoperative	<ul style="list-style-type: none"> <li>• The TX and RX wires are reversed</li> <li>• The VM-CPU and peripheral device baud rate are mismatched</li> <li>• The peripheral device is off-line or improperly configured</li> </ul>

Problem	Possible cause
RS-485 (TB5) network communication inoperative	<ul style="list-style-type: none"> <li>• The network wiring + and – are reversed</li> <li>• The VM-NOC card is not seated properly</li> <li>• The network A and B circuits are crossed</li> <li>• An improper wire was used</li> <li>• The communication card is missing</li> <li>• There is lack of continuity on the network wiring</li> </ul>
No characters on the VM-LCD screen, control-indicating module button inoperative, Power LED off	<ul style="list-style-type: none"> <li>• The ribbon cable between the LCD and CPU is loose or defective</li> <li>• The CPU is defective (replace the entire VM-ELEC electronics chassis)</li> <li>• The LCD is defective (replace the LCD on the VM-ELEC)</li> <li>• The CPU is not configured in the VM-CU for the VM-LCD</li> <li>• There is no power to the panel</li> </ul>

## VM-NOCF Fiber Network Option module troubleshooting

The VM-NOCF Fiber Network Option Module provides a fiber optic or combination fiber optic and RS-485 communication path for up to eight VM-1 control panels. The module consists of an adapter card and electronics card.

Separately ordered fiber optic transceivers are installed on the electronics card to provide transmission and reception capability over the fiber optic cable. The LEDs on the transceivers indicate circuit activity.

**Note:** If a panel must be powered down for service, connect a backup power source to the 24 VDC terminals (TB1) on the electronics card to maintain network communication.

**Figure 42: Fiber optic communication LEDs**

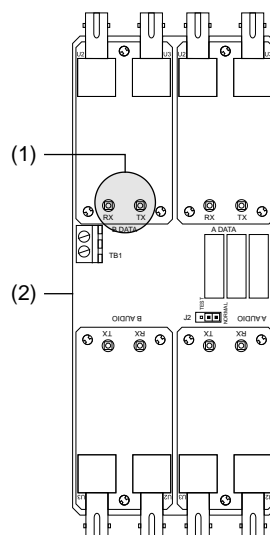

- (1) Transceiver RX/TX LEDs  
 (2) Fiber optic module electronics card

**Table 46: VM-NOCF troubleshooting**

Problem	Possible causes
TX LED not flashing on transceiver	<ul style="list-style-type: none"> <li>The ribbon cable between the adapter card and the electronics card is improperly installed or defective</li> <li>The adapter card is not properly seated in J6 on the CPU</li> </ul>
RX LED not flashing on transceiver	<ul style="list-style-type: none"> <li>An incorrect cable is connected to the port</li> <li>A fiber strand may be broken or missing</li> <li>Lack of continuity between one panel and another</li> </ul>
RX LED steady on transceiver	Jumper JP1 was left in the test position

### Test jumpers

Jumper J2 on the electronics card is used to put the module in test mode. See the *VM-NOCF Fiber Network Option Module Installation Sheet* (P/N 3101783-EN) for testing instructions.

## D12LS-VM control-indicating modules troubleshooting

The D12LS-VM control-indicating modules operate independently of the option card on which they are installed. However, they use the option card's electronics to communicate with the VM-CPU.

The lamp test function will quickly isolate hardware problems from programming problems with any control-indicating module. See "Performing a lamp test" on page 46.

**Table 47: Control-indicating module troubleshooting**

Problem	Possible cause
The LEDs, buttons, and host option card are inoperative	<ul style="list-style-type: none"> <li>There is no power to the panel</li> <li>The ribbon cable between the control-indicating module and the CPU or connected control-indicating module is loose or defective</li> <li>The control-indicating module is defective</li> </ul>
The LEDs and buttons are inoperative, but the host option card is working correctly	<ul style="list-style-type: none"> <li>The ribbon cable between the control-indicating module and the CPU or connected control-indicating module is loose or defective</li> <li>The control-indicating module is not defined in the VM-CU</li> <li>The control-indicating module is defective</li> </ul>
The LEDs respond incorrectly	<ul style="list-style-type: none"> <li>The control-indicating module is not defined in the VM-CU</li> <li>The LED is not identified correctly in the VM-CU</li> <li>A correlation governing LED operation is not correctly written</li> </ul>
A button does not perform the expected function	<ul style="list-style-type: none"> <li>The control-indicating module is not defined in the VM-CU</li> <li>The button is not identified correctly in the VM-CU</li> <li>A correlation governing button operation is not correctly written</li> </ul>

## VM-DACT Dual Line Dialer Card troubleshooting

### LED indicator diagnostics

LINE 1 and LINE 2 LEDs on the VM-DACT provide diagnostic information. See the tables below for a description of the LEDs and their dialing and data transmission states.

**Figure 43: VM-DACT LED indicators**

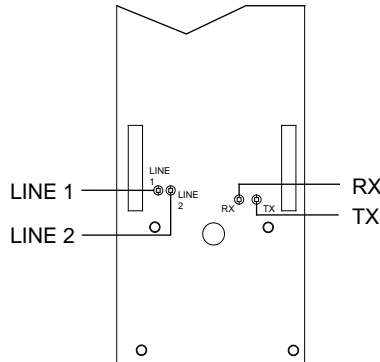

Label	Description	Label	Description
LINE 1	Indicates line 1 telephone activity	RX	Indicates receive activity
LINE 2	Indicates line 2 telephone activity	TX	Indicates transmit activity

**Table 48: VM-DACT LINE 1 and LINE 2 LED states**

LED state	LINE 1 description	LINE 2 description
Off	There is no activity	There is no activity
On	LINE 1 has been seized	LINE 2 has been seized
Slow flash	Dialer or modem data is being passed on LINE 1	Dialer data is being passed on Line 2 (modem data is passed only on LINE 1)
Slow flash (both LEDs)	The application code or configuration code is downloading from the CPU or VM-CU	
Fast flash	Reflects ringing on LINE 1 (flashing pattern detected)	N/A (LINE 2 does not have ring detection)

### Cellular capture module problems

To troubleshoot problems with a cellular capture module, refer to the installation manual received with the module.

### Audible diagnostics

Obtain an audio amplifier device locally for listening to the distinctive sounds associated with dialing, receiving handshakes, transmitting data, and receiving acknowledgements. Place a 0.1  $\mu$ F, 200 V or greater capacitor in series with one of the leads. Alternately, you can use a lineman's handset in monitor mode.

During downloading from a remote computer, you will hear the distinct sound of modems establishing a connection, and then a series of rapid chirps as data is transmitted.

**Note:** Remove the audio amplifier when you finish troubleshooting.

### Common problems

Evaluation of visual and audible indications will usually serve to isolate the source of trouble. Before replacing a VM-DACT, investigate the following common causes of a module problem.

- The module is not properly seated on the electronics chassis, or one or more connector pins are bent away from the associated connectors
- A modular telephone plug is not connected to the appropriate line 1 or line 2 jack, is not fully seated, or is not connected at the telephone block
- The module is configured with incorrect CMS telephone numbers
- The telephone line is faulty

If the module and telephone line are okay, check the CMS telephone number by dialing it using a standard telephone plugged directly into the RJ-31X jack. (The jack will accommodate a standard modular phone plug.) You should:

1. Hear a dial tone when going off-hook
2. Lose the dial tone after dialing the first digit
3. Hear the receiver ringing
4. Hear the CMS receiver go off-hook and send a handshake tone

Typical problems dialing the CMS involve missing or incorrect area codes, the need to dial 1 for long distance, or missing line access codes (for example, dialing 9 for an outside line).

If the receiver answers, check that it is sending out the correct handshake. For Contact ID, the handshake signal consists of two short tones of different frequency. For TAP, there should be a modem-type exchange of handshake messages.

If the receiver sends the correct handshake and the VM-DACT transmits data but the receiver does not send an acknowledgement, check that the receiver is compatible with the desired protocol. Typical problems involve an incompatible format or data message.

If the handshake and acknowledge signals are audible, check that the correct account number was configured in the VM-DACT and the code being sent was correctly programmed in the CMS computer.

Where a VM-DACT module is suspected of being faulty, try substituting a known good one that has been properly programmed.

## VM-PMI Paging Microphone Interface troubleshooting

Figure 44: VM-PMI interface, EAEC card, and VM-CPU

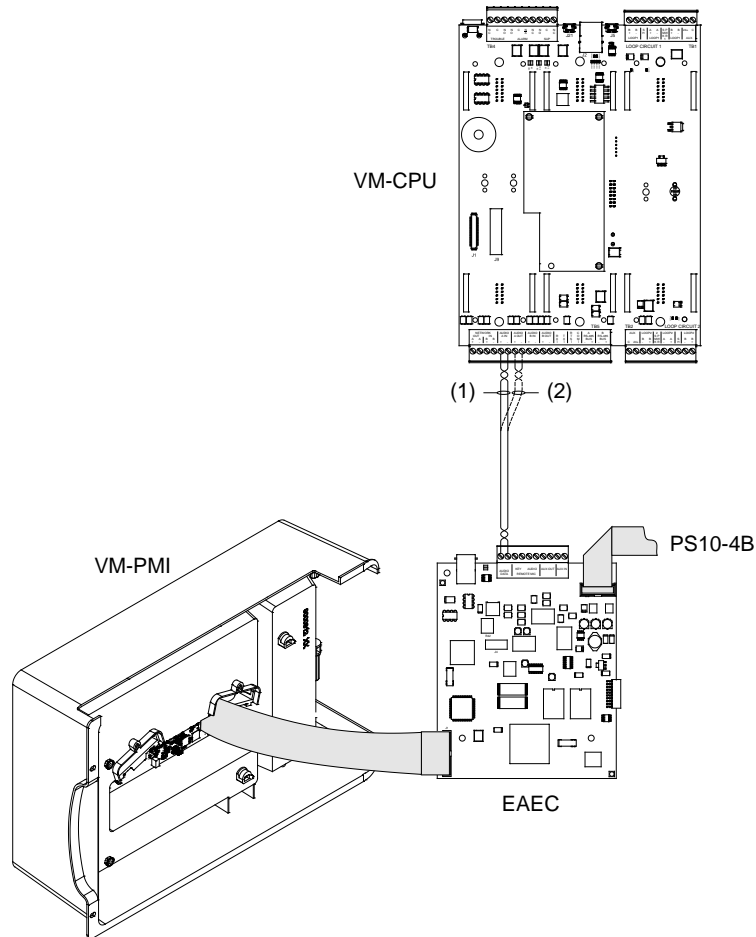

- (1) Network option card installed  
 (2) Network option card not installed

Table 49: VM-PMI Paging Microphone Interface troubleshooting

Problem	Possible cause
The interface does not respond nor is there RX or TX LED activity on the EAEC card	<ul style="list-style-type: none"> <li>The ribbon cable between the VM-PMI audio interface card and EAEC card is loose or defective</li> <li>The ribbon cable between the PS10-4B and the EAEC is missing</li> <li>VM-PMI is not programmed</li> </ul>

Problem	Possible cause
There is no All Call page audio output from network amplifiers or the low level page output terminals	<ul style="list-style-type: none"> <li>• The paging microphone is defective</li> <li>• The page inhibit timer setting in the VM-CU is too long</li> <li>• The EAEC card is defective</li> <li>• The ribbon cable between the VM-PMI audio interface card and EAEC card is loose or defective</li> <li>• The amplifier is defective</li> <li>• The output modules connected to the amplifier are not activating through programming</li> </ul>
There is no All Call page audio output from network amplifiers but output is available at the low level page output terminals	<ul style="list-style-type: none"> <li>• A short or open is detected on the digital audio data riser, or there is incorrect wiring</li> <li>• A short or open has been detected on the network data riser, or there is incorrect wiring</li> <li>• The connection to TB5 on the VM-CPU is loose or incorrectly wired</li> <li>• The VM-PMI is defined incorrectly in the VM-CU</li> <li>• The amplifiers are not properly installed or they are defective</li> <li>• The output modules connected to the amplifier are not activating through programming</li> <li>• The amplifier channel is incorrectly programmed</li> </ul>
Page audio is distorted	<ul style="list-style-type: none"> <li>• The operator is speaking too loud into the microphone</li> <li>• Amplifier gain is set too high</li> </ul>
The auxiliary input volume level is too low	<ul style="list-style-type: none"> <li>• The aux input/output gain control on the EAEC needs adjusted</li> <li>• A short or open is detected on the aux input wiring</li> </ul>
The auxiliary input volume level is too high	<ul style="list-style-type: none"> <li>• The aux input/output gain control on the EAEC needs adjusted</li> <li>• The amplifier output gain is set too high</li> </ul>
Recorded messages are not working properly	<ul style="list-style-type: none"> <li>• The audio database was not correctly downloaded</li> <li>• An incorrect message label was referenced</li> </ul>
Messages are going to wrong floors	<ul style="list-style-type: none"> <li>• The amplifier and message labels, and correlations are incorrect or mislabeled</li> </ul>
The remote microphone is in trouble state	<ul style="list-style-type: none"> <li>• There is a wrong or missing EOL resistor on the microphone key input</li> <li>• There is no supervisory tone on the DC current for the remote microphone audio output</li> </ul>

## Pseudo points

A pseudo point is an input or output point that is not a physical device. For example, ground fault and communication fault notifications. When a pseudo point event occurs, a message displays on the control panel LCD screen that shows the point address and label. You can find the pseudo point source and description by cross-referencing to the pseudo point Address column in the tables that follow.

**Table 50: System pseudo points**

<b>Address</b>	<b>Label</b>	<b>Source</b>	<b>Functional description</b>
0001	Startup Response	CPU	The system changes to the active state when the panel is energized or an operator initiates a restart from the LCD command menu
0002	First Alarm Response	CPU	The system changes to the active state when the first point on a panel or any panel in the same network routing group changes to the alarm state
0003	First Supervisory Response	CPU	The system changes to the active state when the first point on a panel or any panel in the same network routing group changes to the supervisory state
0004	First Trouble Response	CPU	The system changes to the active state when the first point on a panel or any panel in the same network routing group changes to the trouble state
0005	First Monitor Response	CPU	The system changes to the active state when the first point on a panel or any panel in the same network routing group changes to the monitor state
0006	Evacuation Response	CPU	The system changes to the active state when an operator presses a switch that executes the EVAC command
0007	Drill Response	CPU	The system changes to the active state when an operator presses a switch that executes the Drill command
0008	AllCall Response	CPU	The system changes to the active state when an operator presses the All Call or All Call Minus button on the VM-PMI
0009	Alarm Silence Response	CPU	The system changes to the active state when an operator presses a switch that executes the Alarm Silence command
0010	Two Stage Timer Expiration	CPU	The system changes to the active state when a panel's two-stage alarm timer expires
0011	Reset Active	CPU	The system changes to the active state when an operator presses a switch that executes the Reset command
0012	Reset Phase 1	CPU	The system changes to the active state when the first phase of the 3-phase reset cycle starts
0013	Reset Phase 2	CPU	The system changes to the active state when the second phase of the 3-phase reset cycle starts
0014	Reset Phase 3	CPU	The system changes to the active state when the third phase of the 3-phase reset cycle starts
0015	First Disable Response	CPU	The system changes to the active state when the first point on a panel or any panel in the same network routing group changes to the disable state
0016	Fail Safe Event	CPU	The system changes to the active state when a device asserts the rail alarm-not line and the CPU module has not registered an alarm event

Address	Label	Source	Functional description
0017	Service Group Active	CPU	The system changes to the active state when an operator enables a Service group from the LCD command menu
0018	Two Stage Timer Active	CPU	The system changes to the active state when a panel's two-stage alarm timer starts
0019	Loop Controller Reset Extension	CPU	The system changes to the active state when a loop controller stays in the reset mode longer than expected
0020	Service Device Supervision	CPU	The system changes to the active state when an operator cancels a Service group test while a circuit under test remained active
0021	User Trouble	CPU	The system changes to the active state when an operator forces a trouble into the system (not implemented at this time)
0022	Ext Database Incompatibility	CPU	The system changes to the active state when a different database is in one or more network nodes
0023	Reboot Fault	CPU	The system changes to the active state when the CPU module is interrupted unexpectedly
0101–0164	Comm Fail xx	CPU	The system changes to the active state when the CPU is unable to communicate with the networked CPU module in cabinet xx
0200–0222	Task xx Watchdog Violation	CPU	The system changes to the active state when legacy CPU task xx fails to execute properly
0261–0279	Configuration Mismatch Card xx	CPU	The system changes to the active state when the card in slot xx cannot perform the programmed advance feature (currently only when in degraded mode)
0281–0299	DB Out Of Sync with CPU Card xx	CPU	The system changes to the active state when the loop controller in the CPU rail slot xx reports an actual and expected data mismatch
0300-0399	Task xx Watchdog Violation	CPU	The system changes to the active state when VM-1 CPU task xx fails to execute properly

**Table 51: Local alarm pseudo points**

Address	Label	Source	Description
0676	Unprogrammed Device DataCard 1	SLC	A device that is not defined in the VM-CU database is in alarm or trouble state
0686	Unprogrammed Device DataCard2	SLC	A device that is not defined in the VM-CU database is in alarm or trouble state

**Table 52: Local trouble pseudo points**

Address	Label	Source	Description
0001	Class A Fault ANN Device	ANN	There is a fault or break in the Class A loop on the annunciator bus
0002	Class A Fault Video Bus	ANN	There is a fault or break in the Class A loop on the video bus
0003	Annunciator Supervision	ANN	The control-indicating module is faulty or missing, or is not properly configured
0004	Rail Module Communication Fault	ANN	There is a local rail communication failure in the cabinet
0005	Video Communication Fault	ANN	There is a fault or break in the video signal lines
0006	RAM Fault or Stack Fault	ANN	There is a fault in the internal annunciator bus processor
0007	Code Supervision	ANN	The executable program is corrupt
0008	Internal Fault	ANN	There is an annunciator bus hardware failure
0009	Configuration Fault	ANN	A control-display module is in the wrong slot
0010	Database Supervision	ANN	The database is corrupt
0071	Task Failure	ANN	A SAC task fails to run
0600	Annunciator Supervision	General	The control-indicating module is faulty or missing, or not properly configured
0601	Network Class A Failure	CPU	There is a fault or break in the Class A / X network data riser connection
0601	Communication Fault	PS10-4B	A communication fault occurred between the CPU and the PS10-4B module
0601	Rail Module Communication Fault	General	There is a local rail communication failure in the cabinet
0602	Ground Fault Detection	CPU	There is a ground fault with a cabinet component or in field wiring
0603	Audio Supervision	CPU	A short or open is detected on the audio data circuit
0604	Internal Fault	General	There is a CPU hardware failure
0605	Database Supervision	General	The database is corrupt
0605	DB Supervision Audio Default Tone	EAEC	<ul style="list-style-type: none"> <li>• No message is present</li> <li>• There is a problem erasing flash</li> <li>• The message space fails internal checks</li> </ul>
0606	Code Supervision	General	The executable program is corrupt
0607	Auxiliary Port One	CPU	A short or open is detected on the port 1 serial communication circuit
0607	Data Card Fault One	SLC	The VM-SLC card on the loop controller is missing or loose
0607	Bootloader Supervision	EAEC	The audio controller bootloader code is corrupted

Address	Label	Source	Description
0608	Auxiliary Port Two	CPU	A short or open is detected on the port 2 serial communication circuit
0608	Data Card Fault Two	SLC	The VM-SLC card on the loop controller is missing or loose
0608	Waiting for SDU Download	EAEC	The database download from the VM-CU is in progress or incomplete
0609	Panel in Download Mode	CPU	The panel is out of service to accept download data
0609	Configuration Fault	General	A module is in the wrong slot
0610	Network Audio Circuit A Fault	CPU	There is a loss of signal on the primary audio connection
0610	Rail Voltage Out of Spec	PS10-4B	<ul style="list-style-type: none"> <li>The rail voltage is &gt;30 VDC or &lt;21 VDC</li> <li>There is an excessive rail current load</li> <li>The rail is faulty or misadjusted</li> </ul>
0610	Telephone Line 1	DACT	A line-cut fault is detected on phone line 1
0611	Network Audio Circuit B Fault	CPU	There is a loss of signal on the secondary audio connection
0611	Telephone Line 2	DACT	A line-cut fault is detected on phone line 2
0612	Receiver Test Line 1	DACT	The line 1 test transmission to the CMS failed
0612	Unexpected Card	CPU	An undefined card is detected
0613	Low Battery Cut Off	PS10-4B	The battery voltage is below 19.5 VDC when on battery backup
0613	Receiver Test Line 2	DACT	The line 2 test transmission to the CMS failed
0614	AC Brownout	PS10-4B	AC line voltage is below 93 VAC at 50/60 Hz
0614	RS-232 Channel	DACT	There is a communication failure with the RS-232 card on the module
0615	Battery Trouble	PS10-4B	<ul style="list-style-type: none"> <li>There is an open on the wiring</li> <li>The battery voltage is below 20.4 VDC</li> <li>The battery internal resistance is too high (load test failure)</li> </ul>
0616	Network Class A Circuit A Failure	CPU	The CPU is unable to receive data on data riser circuit A
0617	Network Class A Circuit B Failure	CPU	The CPU is unable to receive data on data riser circuit B
0617	DSP Supervision	DACT	The DSP chip on the module failed
0617	Power Supply Failure	PS10-4B	<ul style="list-style-type: none"> <li>The cables between the power supply and CPU are loose or missing</li> <li>The power supply is defective</li> </ul>
0619	Charger Over Current	PS10-4B	<ul style="list-style-type: none"> <li>The cables between the power supply and CPU are loose or missing</li> <li>The power supply or CPU is defective</li> </ul>

Address	Label	Source	Description
0620	Battery Internal Resistance Trbl	PS10-4B	Battery is degraded
0620	Demux Audio Input	ACHS	The digitized audio data is missing
0620	Waiting for SDU Download	DACT	A database download from the VM-CU is in progress or incomplete
0621	NAC Charge Pump Trouble	PS10-4B	<ul style="list-style-type: none"> <li>The charge pump for the NACs is in trouble state</li> <li>The NAC charge pump voltage is below 30V, preventing the NACs from operating</li> <li>The power supply is defective</li> </ul>
0621	Amplifier Overcurrent	ACHS	<ul style="list-style-type: none"> <li>A short is detected on the circuit</li> <li>The speaker wattage tap setting exceeds the output rating of the amplifier</li> </ul>
0622	Primary Audio Output DC	ACHS	<ul style="list-style-type: none"> <li>There is an open DC NAC circuit, or missing or wrong value EOL resistor</li> <li>A short is detected on the a DC NAC circuit</li> </ul>
0622	Rail Over Current Trouble	PS10-4B	The power supply detected an over current condition (> 10A)
0623	Battery Charger Trouble	PS10-4B	The charger may not be able to charge the batteries
0623	Primary Audio Output Analog	ACHS	<ul style="list-style-type: none"> <li>There is an open Audio NAC circuit, or missing or wrong value EOL resistor</li> <li>A short is detected on the Audio NAC circuit</li> <li>The output voltage jumper is set wrong</li> </ul>
0624	Application Fault	PS10-4B	The power supply detected a fault while testing its internal subsystems
0624	Backup Audio Output Analog	ACHS	<ul style="list-style-type: none"> <li>There is an open audio NAC circuit, or missing or wrong value EOL resistor</li> <li>A short is detected on the Audio NAC circuit</li> <li>The output voltage jumper is incorrectly set</li> </ul>
0625	Amplifier Daughter Board	ACHS	The board is defective
0626	Thermistor Supervision	PS10-4B	The thermistor is either missing or not functioning
0626	Fuse Supervision	ACHS	There is an open fuse on the amplifier
0627	Measurement Trouble	PS10-4B	The A/D readings are not reliable
0627	PAL Supervision	ACHS	The PAL chip on the amplifier is bad
0628	NAC Class A Mismatch	PS10-4B	<ul style="list-style-type: none"> <li>The expected Class A configuration does not match actual hardware</li> <li>The CLA-PS10 adapter is missing</li> </ul>
0630	Riser Supervision	FTCU	A short or open is detected on the telephone riser
0631	User Interface	FTCU	A board fault is detected
0632	Master Phone Supervision	FTCU	A short or open occurred on the phone handset

Address	Label	Source	Description
0633	Handset Off Hook	FTCU	The firefighter telephone is off the hook
0652	Phone/Mic/Remote Mic ACSprvs	EAEC	Defective microphone or connections are detected
0653	Phone Page Time Out	EAEC	The phone page switch activated for a period that exceeded the time limit set in the VM-CU
0654	Audio Hardware Mismatch	EAEC	N/A
0655	RAM Diag Failure	EAEC	There is a memory failure on the EAEC
0656	Audio Default Failure	EAEC	<ul style="list-style-type: none"> <li>The memory card is missing</li> <li>The audio database does not exist</li> </ul>
0657	All Call Minus	EAEC	The All Call Minus feature is activated
0658	Audio Intrfce Failed to Start	EAEC	There is a VM-PMI hardware fault
0659	Audio Class Supervision	EAEC	A short or open is detected on a riser
0670	Waiting for SDU Download	SLC	A database download from the VM-CU is in progress or incomplete
0671	Open/Short Fault DataCard1	SLC	A wiring fault is detected
0672	Map Fault DataCard1	SLC	<ul style="list-style-type: none"> <li>A mismatch between the actual data and expected data occurred</li> <li>Wiring is defective</li> <li>A device is defective</li> </ul>
0677	Ground Fault DataCard1	SLC	A wiring fault is detected
0679	Smoke Power Current Limit Card1	SLC	N/A
0680	Unused DataCard1	SLC	N/A
0681	Invalid Response Instruction	CPU	<ul style="list-style-type: none"> <li>A programmed response has an invalid instruction</li> <li>The database is possibly corrupt</li> </ul>
0681	Open/Short Fault DataCard2	SLC	<ul style="list-style-type: none"> <li>A short is detected on the circuit</li> <li>An open is detected on a Class A circuit</li> </ul>
0682	Main Board Internal Fault	CPU	The CPU on the control panel detected an internal fault on the main board
0682	Map Fault DataCard2	SLC	<ul style="list-style-type: none"> <li>There is a mismatch between the actual data and expected data</li> <li>Wiring is defective</li> <li>A device is defective</li> </ul>
0683	Main Board Communication Fault	CPU	CPU daughter card communication with the CPU main board failed
0684	Network Compatibility Fault	CPU	The network option card is not compatible with the network configuration
0685	24V Auxiliary Output Fault	CPU	The AUX board on the CPU is faulty (e.g., shorted)

Address	Label	Source	Description
0686	Ethernet Card Configuration Fault	CPU	The expected Ethernet card type does not match the actual
0687	Ethernet Card Internal Fault	CPU	The CPU on the Ethernet card detected an internal fault
0687	Ground Fault DataCard2	SLC	<ul style="list-style-type: none"> <li>There is a wiring fault</li> <li>The conductor connected to the data card has continuity to ground</li> </ul>
0688	DHCP_Communication_Fault	CPU	Loss of communication with the DHCP server
0689	DNS_Communication_Fault	CPU	Loss of communication with the DNS server
0689	Smoke Power Current Limit Card2	SLC	A fault occurred on the smoke power circuit of SLC2
0690	IP_Service_1_Primary_Communication_Fault	CPU	Loss of communication with the external device configured as the primary device for IP ServiceID 1
0690	Unused DataCard2	SLC	N/A
0691	IP_Service_1_Alternate_Communication_Fault	CPU	Loss of communication with the external device configured as the secondary device for IP ServiceID 1
0691	Map Mismatch DataCard1	SLC	The Expected map on loop 1 does not map to the Actual
0692	IP_Service_2_Primary_Communication_Fault	CPU	Loss of communication with the external device configured as the primary device for IP ServiceID 2
0692	Map Mismatch DataCard2	SLC	The Expected map on loop 2 does not map to the Actual
0693	IP_Service_2_Alternate_Communication_Fault	CPU	Loss of communication with the external device configured as the secondary device for IP ServiceID 2
0693	Too Many Devices DataCard1	SLC	The number of sensors or modules attached to loop 1 exceeded the maximum allowed
0694	IP_Service_3_Primary_Communication_Fault	CPU	Loss of communication with the external device configured as the primary device for IP ServiceID 3
0694	Too Many Devices DataCard2	SLC	The number of sensors or modules attached to loop 2 exceeded the maximum allowed
0695	IP_Service_3_Alternate_Communication_Fault	CPU	Loss of communication with the external device configured as the secondary device for IP ServiceID 3
0695	Inhibit Normal Flash Bypassed Datacard1	SLC	On the VM-SLCXB loop controller, Inhibit Normal Flash mode has been bypassed. Device LEDs will flash according to state.
0695	Bypassed_Datacard1_01_03	SLC	On the VM-SLCXB loop controller, Inhibit Normal Flash mode has been bypassed. Device LEDs will flash according to state.

Address	Label	Source	Description
0696	IP_Service_4_Primary_Communication_Fault	CPU	Loss of communication with the external device configured as the primary device for IP ServiceID 4
0696	Inhibit Normal Flash Bypassed Datacard2	SLC	On the VM-SLCXB loop controller, Inhibit Normal Flash mode has been bypassed. Device LEDs will flash according to state.
0696	Bypassed_Datacard 2_01_03	SLC	On the VM-SLCXB loop controller, Inhibit Normal Flash mode has been bypassed. Device LEDs will flash according to state.
0697	IP_Service_4_Alternate_Communication_Fault	CPU	Loss of communication with the external device configured as the secondary device for IP ServiceID 4
0698	IP_Service_5_Primary_Communication_Fault	CPU	Loss of communication with the external device configured as the primary device for IP ServiceID 5
0699	IP_Service_5_Alternate_Communication_Fault	CPU	Loss of communication with the external device configured as the secondary device for IP ServiceID 5
0700	IP_Service_6_Primary_Communication_Fault	CPU	Loss of communication with the external device configured as the primary device for IP ServiceID 6
0701	IP_Service_6_Alternate_Communication_Fault	CPU	Loss of communication with the external device configured as the secondary device for IP ServiceID 6
0702	IP_Service_7_Primary_Communication_Fault	CPU	Loss of communication with the external device configured as the primary device for IP ServiceID 7
0703	IP_Service_7_Alternate_Communication_Fault	CPU	Loss of communication with the external device configured as the secondary device for IP ServiceID 7
0704	IP_Service_8_Primary_Communication_Fault	CPU	Loss of communication with the external device configured as the primary device for IP ServiceID 8
0705	IP_Service_8_Alternate_Communication_Fault	CPU	Loss of communication with the external device configured as the secondary device for IP ServiceID 8

**Table 53: R-Series / K-R-Series annunciator local trouble pseudo points**

Address [1]	Label	Source	Description
xx90	Annunciator Communications	ANN	A communication fault occurred between the panel and an R-Series / K-R-Series annunciator
xx91	Annunciator RAM Supervision	ANN	An R-Series / K-R-Series annunciator RAM fault was detected
xx92	Annunciator CH1 Communications	ANN	N/A
xx93	Annunciator Configuration	ANN	<ul style="list-style-type: none"> <li>The R-Series / K-R-Series annunciator configuration does not match the actual hardware</li> <li>The R-Series / K-R-Series expander is not communicating with the R-Series / K-R-Series annunciator</li> </ul>
xx94	Annunciator Class A	ANN	N/A
xx95	Ann DB Supervision	ANN	The R-Series / K-R-Series annunciator database is corrupt
xx96	Annunciator Code Supervision	ANN	The R-Series / K-R-Series annunciator database is corrupt

[1] Up to 30 annunciators can be configured per cabinet. The first two digits in the address column represent the annunciator number. See Table 54.

**Table 54: Annunciator address set**

Annunciator	Address set	Annunciator	Addresses set
1	0290-0296	16	4790-4796
2	0590-0596	17	5090-5096
3	0890-0896	18	5390-5396
4	1190-1196	19	5690-5696
5	1490-1496	20	5990-5996
6	1790-1796	21	6290-6296
7	2090-2096	22	6590-6596
8	2390-2396	23	6890-6896
9	2690-2696	24	7190-7196
10	2990-2996	25	7490-7496
11	3290-3296	26	7790-7796
12	3590-3596	27	8090-8096
13	3890-3896	28	8390-8396
14	4190-4196	29	8690-8696
15	4490-4496	30	8990-8996

**Table 55: Local monitor pseudo points**

Address	Label	Source	Description
0615	Incoming Ring	DACT	An incoming call was received
0622	Outgoing Call in Progress	DACT	The dialer is active
0629	Request Backup	ACHS	N/A
0650	All Call Active	PMI	An operator presses the All Call switch
0651	Mic Key Active	PMI	An operator presses the PTT switch on the paging microphone
0673	Mapping In Progress DataCard1	SLC	The loop controller is currently mapping the devices in the field
0674	Mapping Disabled DataCard1	SLC	Mapping was manually disabled
0675	Dev. Maintnc Alert DataCard1	SLC	A detector on loop 1 is dirty
0678	Reconstructng Line DataCard1	SLC	N/A
0683	Mapping In Progress DataCard2	SLC	N/A
0684	Mapping Disabled DataCard2	SLC	Mapping was manually disabled
0685	Dev. Maintnc Alert DataCard2	SLC	A detector on loop 2 is dirty
0688	Reconstructng Line DataCard2	SLC	N/A
0706	Control_Center_Active_ IP_Service_1	CPU	A control center connected through the gateway for IP ServiceID 1 is active
0707	Control_Center_Active_ IP_Service_2	CPU	A control center connected through the gateway for IP ServiceID 2 is active
0708	Control_Center_Active_ IP_Service_3	CPU	A control center connected through the gateway for IP ServiceID 3 is active
0709	Control_Center_Active_ IP_Service_4	CPU	A control center connected through the gateway for IP ServiceID 4 is active
0710	Control_Center_Active_ IP_Service_5	CPU	A control center connected through the gateway for IP ServiceID 5 is active
0711	Control_Center_Active_ IP_Service_6	CPU	A control center connected through the gateway for IP ServiceID 6 is active
0712	Control_Center_Active_ IP_Service_7	CPU	A control center connected through the gateway for IP ServiceID 7 is active
0713	Control_Center_Active_ IP_Service_8	CPU	A control center connected through the gateway for IP ServiceID 8 is active
0714	Ctrl Center Enabled	CPU	The control center has been enabled by an access level override.

Address	Label	Source	Description
0715	Ctrl Center Enabled Port 1	CPU	A control center connected through the Port 1 gateway has been enabled by an access level override.
0716	Ctrl Center Enabled Port 2	CPU	A control center connected through the Port 2 gateway has been enabled by an access level override.
0717	Ctrl Center Enabled IP Service 1	CPU	A control center connected through the gateway for IP ServiceID 1 has been enabled by an access level override.
0718	Ctrl Center Enabled IP Service 2	CPU	A control center connected through the gateway for IP ServiceID 2 has been enabled by an access level override.
0719	Ctrl Center Enabled IP Service 3	CPU	A control center connected through the gateway for IP ServiceID 3 has been enabled by an access level override.
0720	Ctrl Center Enabled IP Service 4	CPU	A control center connected through the gateway for IP ServiceID 4 has been enabled by an access level override.
0721	Ctrl Center Enabled IP Service 5	CPU	A control center connected through the gateway for IP ServiceID 5 has been enabled by an access level override.
0722	Ctrl Center Enabled IP Service 6	CPU	A control center connected through the gateway for IP ServiceID 6 is active
0723	Ctrl Center Enabled IP Service 7	CPU	A control center connected through the gateway for IP ServiceID 7 has been enabled by an access level override.
0724	Ctrl Center Enabled IP Service 8	CPU	A control center connected through the gateway for IP ServiceID 8 has been enabled by an access level override.

**Table 56: Nonsupervised output pseudo points**

Address	Label	Source	Description
0621	Manual Answer Control	DACT	The module answers incoming calls

**Table 57: Local relay pseudo points**

Address	Label	Source	Description
0003	Channel 1 Relay Confirmation	ACHS	The panel changes to the active state when the amplifier's input relay selects channel 1
0004	Channel 2 Relay Confirmation	ACHS	The panel changes to the active state when the amplifier's input relay selects channel 2
0005	Channel 3 Relay Confirmation	ACHS	The panel changes to the active state when the amplifier's input relay selects channel 3
0006	Channel 4 Relay Confirmation	ACHS	The panel changes to the active state when the amplifier's input relay selects channel 4

Address	Label	Source	Description
0011	Page Select	ACHS	The panel changes to the active state when the amplifier's input relay selects the Page channel

**Table 58: Logic group pseudo points**

Address	Label	Description
0024000x	Text_Group xx	The user-defined Instruction Text group has triggered an event (possible addresses are 00240001 to 00240999)
0025000x	Zone_Group xx	The user-defined Zone group has triggered an event (possible addresses are 00250001 to 00250999)
0026000x	Service_Group xx	The user-defined Instruction Service group has triggered an event (possible addresses are 00260001 to 00260255)
0027000x	AND_Group xx	The user-defined AND group has triggered an event (possible addresses are 00270001 to 00270999)

## Understanding VM signaling line circuits

### Operation

The advanced features of the loop controller perform a number of advanced operations. These operations are not always apparent from the control panel. Table 59 lists a number of signaling line circuit conditions and describes the loop's operational responses.

**Table 59: VM-1 signaling line circuit operation**

When you	Response
Remove a detector, and then reinstall the detector in the same base.	<ul style="list-style-type: none"> <li>A system trouble displays on the LCD screen when the detector is removed. The message shows the detector's label or address.</li> <li>The system restores when the detector is reinstalled.</li> </ul>
Remove a module or pull station, and then reinstall the module/pull station in the same location.	<ul style="list-style-type: none"> <li>A system trouble displays on the LCD screen when the module/pull station is removed. The message shows the device's label or address.</li> <li>The system restores when the module/pull station is reinstalled.</li> </ul>
Remove a detector, and then install a different detector of the same type in the same base.	<ul style="list-style-type: none"> <li>A system trouble displays on the LCD screen when the detector is removed. The message shows the detector's label or address.</li> <li>The loop controller remaps the circuit, replacing the serial number of the old detector with the serial number of the new detector, when mapping is enabled. All of the old detector's sensitivity and verification settings are transferred to the new detector. The system returns to normal when mapping is finished.</li> <li>The communication fault for the old detector remains, when mapping is disabled.</li> </ul>

When you	Response
<p>Remove a module or pull station, and then reinstall a different module/pull station of the same type in the same location.</p> <p><b>Note:</b> A GSA-UM replacement module must have jumper JP1 set in the same position as the original module.</p>	<ul style="list-style-type: none"> <li>• A system trouble displays on the LCD screen when the module/pull station is removed. The message shows the device's station label or address.</li> <li>• The loop controller remaps the circuit, replacing the serial number of the old device with the serial number of the new device, when mapping is enabled. If the devices are modules (not pull stations), the old module's personality codes are transferred to the new module. The system returns to normal when mapping is finished.</li> <li>• The communication fault for the old detector remains, when mapping is enabled.</li> </ul>
<p>Remove a detector, and then reinstall a different detector type in the same base.</p>	<ul style="list-style-type: none"> <li>• A system trouble displays on the LCD screen when the detector is removed. The message shows the detector's label or address.</li> <li>• The loop controller remaps the circuit, replacing the serial number of the old detector with the serial number of the new detector, when mapping is enabled. All of the old detector's sensitivity and verification settings are transferred to the new detector. The new detector will be operational but a system trouble displays, indicating a device type mismatch. To clear the trouble, the new detector type must be assigned to the base using the VM-CU and the database downloaded to the panel.</li> <li>• The communication fault for the old detector remains, when mapping is enabled.</li> </ul>
<p>Remove a module or pull station, and then reinstall a different module/pull station type in the same location.</p>	<ul style="list-style-type: none"> <li>• A system trouble displays on the LCD screen when the module/pull station is removed. The message shows the device's station label or address.</li> <li>• The loop controller remaps the circuit, replacing the serial number of the old device with the serial number of the new device, when mapping is enabled. The new device is <i>not</i> operational. A system trouble displays, indicating a device type mismatch. To clear the trouble, the new device type must be defined using the VM-CU and the database downloaded to the panel.</li> <li>• The communication fault for the old detector remains, when mapping is enabled.</li> <li>• If a single address module is replaced with a dual address module or vice versa, a map fault is generated by the address count mismatch.</li> </ul>

## Signaling line circuit troubleshooting basics

The VM-SLC signaling line circuit card provides one Class B, Class A, or Class X signaling line circuit that supports up to 125 detector and 125 module addresses. The card also provides resettable 24 VDC for powering conventional two-wire smoke detector circuits on V-Series modules. When a device is removed from the loop, the loop controller recognizes the change and the control panel processes the information.

**Note:** The VM-SLC-HC is an optional replacement card for the VM-SLC. The VM-SLC-HC should be used for installations where the signaling line circuit has more than 90 isolator modules and isolator bases (with V-Series sensors installed).

### Isolating circuit and device problems

The process of isolating a problem on a signaling line circuit is similar to that used on a conventional fire alarm Initiating Device Circuit (IDC). An accurate and complete wiring diagram of the loop is the best troubleshooting aid available. When used in conjunction with the information provided by the control panel, you can easily isolate open conditions or defective devices. The loop shown in Figure 45 on page 148 will be used to illustrate basic troubleshooting techniques.

**Note:** When troubleshooting Class A loops, disconnect the circuit from the return (loop A) terminals and temporarily jumper both loop A terminals to the respective loop B terminals. You can then troubleshoot the circuit as a Class B circuit.

**Figure 45: Normal signaling line circuit topology**

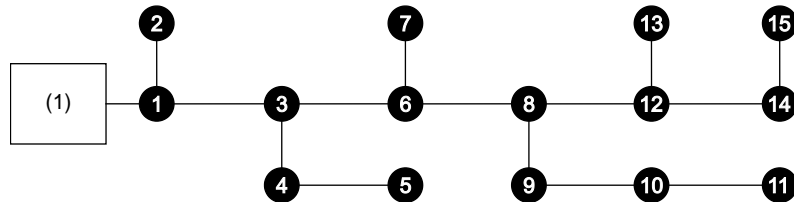

(1) Loop controller

### Open circuit conditions

On a circuit with an open fault, the modules communicate with devices up to the break and the LCD screen displays a trouble condition for all devices beyond the break. Figure 46 shows devices 1 through 7 continuing to operate and devices 8 through 15 reporting device troubles.

**Figure 46: Open fault on the loop**

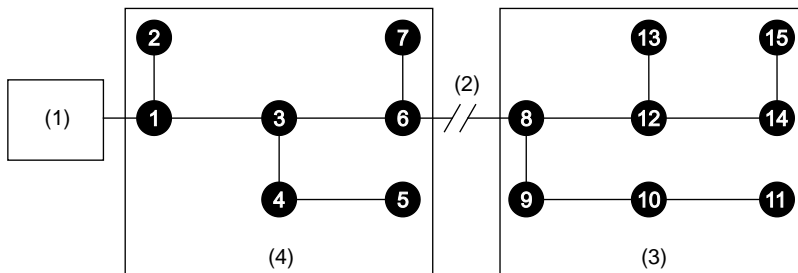

- (1) Loop controller
- (2) Break in the loop
- (3) Devices in trouble
- (4) Devices operating normally

In Figure 46, a wire break or intermittent connection between devices 6 and 8 is the most probable cause of the failure. Other possible causes include a device failure in devices 9 through 15, failure to define them in the loop controller's database, or failure to define them correctly in the VM-CU.

### Short circuit conditions

Short circuit conditions require selective isolation of portions of the loop controller circuit to systematically narrow down the fault's location. A shorted circuit typically shows a trouble condition on all devices, as shown in Figure 47 on page 149.

Figure 47: Wiring short on the loop

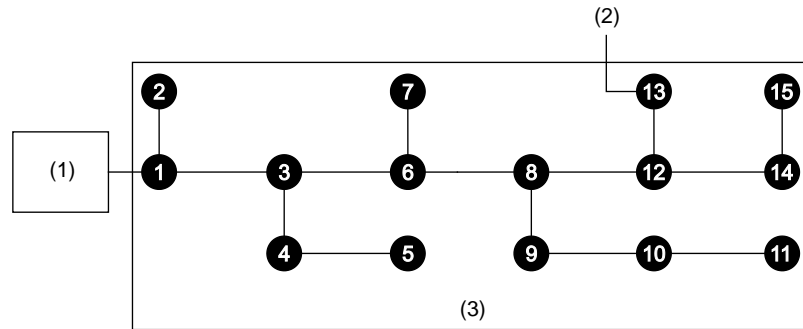

- (1) Loop controller
- (2) Wiring short
- (3) Devices in trouble

To isolate the short, open the loop at a point that will disconnect approximately 50% of the installed devices, as shown in Figure 48.

Figure 48: Isolating a short on the loop

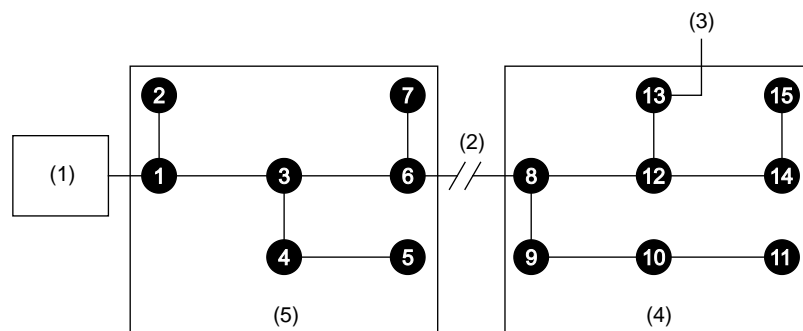

- (1) Loop controller
- (2) Open in loop to isolate the short
- (3) Wiring short location
- (4) Devices remain in trouble
- (5) Devices return to operation

After opening the loop, if some of the devices restore, the short is located on the portion of the loop that has been disconnected. If no devices restore, the short has been isolated to the first 50% of the loop.

Reconnect the previously isolated portion of the loop. If during the first isolation process some devices restored, open the loop at a location *electrically farther* from the loop controller and repeat the analysis. If during the first process no devices restored, open the loop at a location *electrically closer* to the loop controller, and then repeat the analysis. Continue increasing or decreasing the number of devices on the opened loop leg until you isolate the device or wire segment causing the problem.

### Distinguishing short circuits from off-hook conditions in telephone risers

If local regulations require the ability to distinguish between a short circuit and an off-hook condition in a telephone riser, you must configure the circuit so that it functions as a four-state telephone. Compatible riser selector modules and telephone sets are listed below.

- GSA-CC1 riser selector
- GSA-CC1S riser selector

- GSA-MCC1 riser selector
- GSA-MCC1S riser selector
- Portable handset and receptacle (P/N 6830-3 and 6833-4) telephone module
- Remote telephone and wall box, Break Glass (P/N 6830-4 and 6831-1, or 6831-3) telephone module
- Remote telephone and wall box, Nonbreak Glass (P/N 6830-4 and 6831-2, or 6831-4) telephone module

**Note:** For instructions on configuring a four-state telephone, refer to the installation sheet supplied with the GSA input or output module.

**Ground fault conditions**

Ground fault conditions require selective isolation of portions of the loop to systematically narrow down the fault's location. A loop with a ground fault (approximately 10 kΩ or less to ground) causes the Ground Fault LED on the control panel user interface to indicate. The fault conditions can occur on the loop, the 24 VDC smoke power circuit, or the input circuits to the loop controller on the CPU and the VM-SLCXB loop controller. The general location of a ground fault can be determined by viewing a Trouble Report (see "Status reports" on page 40) or by indications and messages on the control panel user interface (see Table 60).

**Table 60: Ground fault indications**

Control panel user interface indications	Ground fault location
The GND Fault LED is on but no device trouble message shows on the LCD screen	<ul style="list-style-type: none"> <li>• Loop controller circuit</li> <li>• 24 VDC smoke power circuit</li> </ul>
The GND Fault LED is on and a device trouble message with the device address shows on the LCD screen	Positive leg of the input circuit for the device

**Figure 49: Loop ground faults**

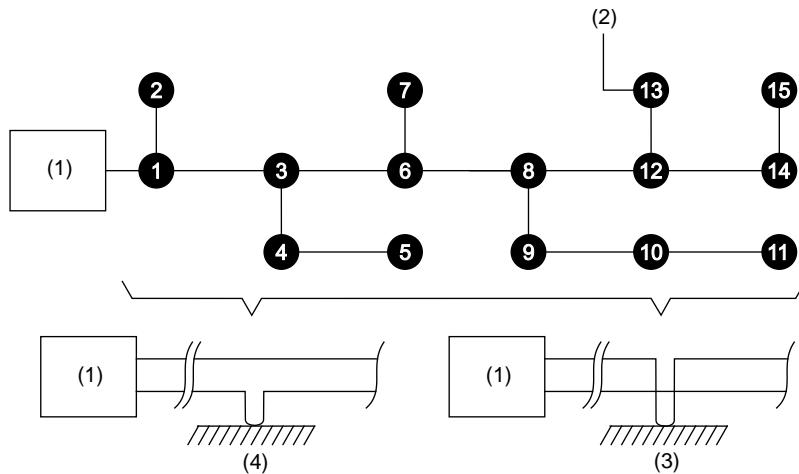

- (1) Loop controller
- (2) Ground fault location
- (3) Positive ground fault
- (4) Negative ground fault

To isolate the ground fault, open the suspect loop (both conductors) at a location that will disconnect approximately 50% of the installed devices as shows in Figure 50. A similar technique is used on smoke power or module input circuits.

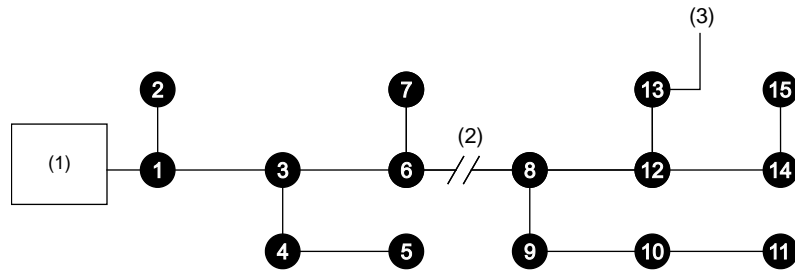
**Figure 50: Ground fault isolation**

- (1) Loop controller (ground fault LED Off)  
 (2) Both conductors open isolates the ground fault  
 (3) Ground fault

After opening the loop, if the Ground Fault LED goes out, the ground fault is located on the portion of the circuit that has been disconnected. If the LED remains on and no devices restore, the short has been isolated to the first 50% of the circuit.

Reconnect the previously isolated portion of the circuit. If during the first isolation process, the Ground Fault LED went off, open the loop at a location *electrically farther* from the loop controller and repeat the analysis. If during the first process the Ground Fault LED remained on, open the loop at a location *electrically closer* to the loop controller, and then repeat the analysis. Continue increasing or decreasing the number of devices on the opened loop leg until you isolate the single device or wire segment causing the problem.

#### Notes

- The ground fault detection circuitry requires approximately 30 to 40 seconds to respond when the fault is removed.
- The VM-1 control panel performs a ground fault test for 2 seconds at 18-second intervals. If the system is working properly, the voltage between earth ground and logic negative should be between 12.3 VDC and 16.8 VDC during the 2-second test. The system reports a ground fault when the voltages are less than 12.3 and more than 16.8 VDC. In a non-faulted system, the voltage outside the 2-second test period may float randomly. If the system is faulted, then the voltage is likely to be a fixed value such as 3 or 19 VDC.

## Substituting devices

When substituting a *known good* detector or module in place of a suspect device, one of two scenarios can take place.

1. If the substituted device is the same model as the suspect device, the system accepts it with no further operator action. When the substituted device is installed, the system goes into trouble. When the quantity of devices defined on the circuit is reached, the system automatically remaps the circuit, stores the revised information, and returns to normal. This process may take a few minutes.
2. If the substituted device is a different model than the suspect device when the device count is correct, the loop controller automatically remaps the circuit. A trouble occurs at the address of the suspect device as the result of a map fault, because the known good device's parameters differ from those of the removed suspect device. You must accept the parameters of the known good device to remove the fault.

#### Detectors

When one or more devices are removed from a loop for servicing, as shown in Figure 51 on page 152 the control panel LCD screen displays a trouble condition for each device. If the control panel is connected to the computer running the VM-CU, the Current Status tab on the V-Series Status / Diagnostics window indicates a trouble condition.

**Note:** If the detector is removed from an isolator base, the isolator will transfer.

**Figure 51: Detectors removed for service**

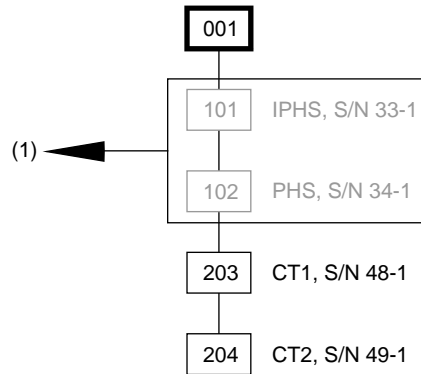

(1) Removed detectors

If the devices are returned to their original locations, as shown in Figure 52, the map supervision function recognizes the detectors have been returned as originally installed and mapped, and no additional action is taken.

**Figure 52: Detectors returned to original location**

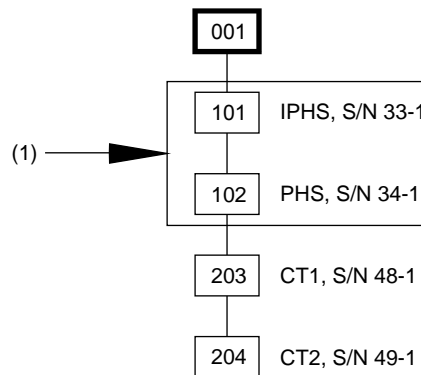

(1) Detectors returned

If the devices are returned to different locations, the map supervision function recognizes that previously mapped serial numbers occupy new map locations. When the mapping supervision function recognizes the need to remap the loop, the panel is put in the map pending state. In the map pending state, the panel automatically remaps the loop when the quantity of reinstalled devices is equal to or greater than the quantity of devices defined in the original map. If the control panel is connected to the computer running the VM-CU, the Current Status tab on the V-Series Status / Diagnostics window indicates *Mapping Pending*.

In Figure 53, the PHS, S/N 341 detector originally installed at address 102 has been installed in the location originally occupied by the IPHS, S/N 33-1 detector.

**Figure 53: One detector returned to a new location on the circuit**

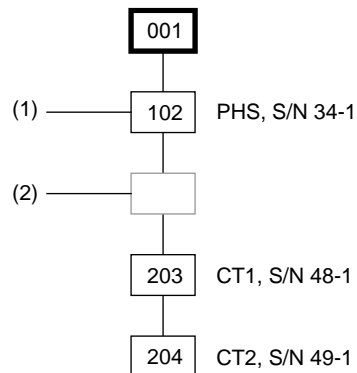

- (1) PHS, S/N 34-1 detector installed in a new location
- (2) IPHS, S/N 33-1 detector not installed

Until all devices are returned on the loop and the loop automatically remaps, the original S/N-to-panel address correlation is still valid. Figure 53, shows that the device address moves with the detector until the loop is remapped. In this example, relocating the PHS detector temporarily relocated address 102. Until all devices are returned and the loop remapped, testing a relocated detector will cause the panel to respond as though the detector was still installed in its original location.

During mapping, all devices remain operational and are capable of initiating an alarm. Figure 54 on page 153 shows that both the IPHS and the PHS detectors retain their old S/N to address correlations while the circuit is mapping. Mapping activity is indicated on the control panel LCD screen. If the control panel is connected to the computer running the VM-CU, the Current Status tab on the V-Series Status / Diagnostics window indicates *Mapping in Progress*.

Once mapped, the mapping supervision function automatically correlates a panel address to a specific map location until manually changed using the VM-CU configuration utility.

**Figure 54: Both detectors returned to new locations**

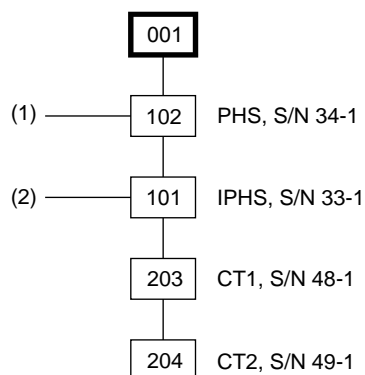

- (1) PHS, S/N 34-1 detector returned to service in new location before remapping
- (2) IPHS, S/N 33-1 detector returned to service in new location before remapping

Figure 55 shows the map after remapping. Note that the new S/N-to-panel address correlations have been made. The IPHS detector is now correlated with address 102 and the PHS detector is correlated with address 101. The relocated devices will now respond as programmed for the original address location.

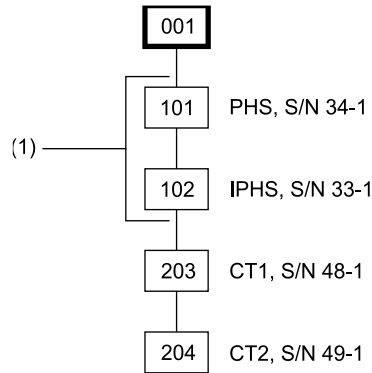
**Figure 55: Both detectors remapped**

(1) Remapped detectors PHS, S/N 34-1 and IPHS, S/N 33-1

When a factory-new detector replaces an in-service detector, the new detector is operational with a default address of 00 until it is mapped. When the loop is remapped, the new detector is given the address assigned to its map location. If a factory-new detector is added over and above the expected number of devices on the loop, it is operational with a default address of 00. However, the panel reports a trouble because the *actual map* contains one more device than the *expected map*.

### Modules

When a module is replaced with another module of the same type, automatic remapping assigns the replacement module the personality code of the module originally installed at that map location.

If a module is replaced with a module of a different type one of three things can happen.

1. If a single address module, such as the GSA-CT1 or GSA-CC1, is replaced with a different type of single input module, the loop remaps all devices. However, the new module type will not operate because of incompatible personality codes. A map fault generates because the actual module differs from the expected module. The new module type must be defined in the VM-CU and the database downloaded into the panel. The map fault will then clear.
2. If a single address module is replaced with a dual address module, the panel unsuccessfully attempts to remap all devices. A map fault generates because the actual device differs from the expected device and the dual address module does not operate. To clear the map fault, define the new module using the VM-CU, and then download the database into the panel.
3. If a dual address module is replaced with a single address module, the panel never automatically attempts to remap all devices because the panel does not see enough devices (one address less) to remap the loop. A manual remap will also be unsuccessful. A map trouble shows on the control panel LCD screen as the panel remains in the map pending mode. To clear the trouble, define the new module using the VM-CU, and then download the database into the panel.

### Notes

- Do not replace factory-programmed devices such as pull stations and MM1 modules with a GSA-CT1.
- For mapping purposes, give all manual pull stations the device type *Pull*, regardless of their model numbers.

### Device type replacement

If a different V-Series device model is substituted for a suspect device, when the device count is correct the loop controller automatically remaps the loop. A trouble occurs at the address of the suspect device as the result of a map fault, because the known good device's parameters differ from those of the removed device. To clear the map fault, accept the parameters of the known good device. You can change the parameters later.

**Note:** V-Series devices require a solid connection at their terminals. If a wire can wiggle, it is subject to contact resistance variations due to temperature changes. A loose wire can result in an intermittent connection, which will affect communication between the devices and the control module. Using a proper size screwdriver, securely tighten all wiring connections.

## Substituting loop controllers

When substituting a known good loop controller, the replacement must be defined in the VM-CU and the database downloaded into the panel. See “Downloading a database” on page 51.

### VM-CPU loop controller

The VM-CPU main board on the VM-ELEC electronics chassis has a built-in loop controller that provides two signaling line circuits.

If you determine that the loop controller is responsible for loop faults, substitute the VM-SLC card installed on the VM-CPU. Refer to the *VM-SLC Signaling Line Circuit Card Installation Sheet* (P/N 3101785-EN).

If substituting the VM-SLC card does not resolve the problem, you must then replace the VM-ELEC chassis that provides the mounting, internal power, and audio and data distribution for the VM-CPU main board and supporting cards. Refer to the *VM-ELEC Chassis Electronics Assembly Installation Sheet* (P/N 3101780-EN).

### VM-SLCXB loop controller

The VM-SLCXB loop controller is an option module that can be installed on the VM-ELEC electronics chassis.

If you determine that the loop controller is responsible for loop faults, substitute either the VM-SLC card installed on the VM-SLCXB or the VM-SLCXB module. Refer to the *VM-SLC Signaling Line Circuit Card Installation Sheet* (P/N 3101785-EN) or *VM-SLCXB Signaling Line Loop Controller Expansion Card Installation Sheet* (P/N 3102128-EN).

## Loop controller troubleshooting

Table 61 below provides a list of possible problems that may be detected by the loop controller module. For information on identifying and locating data loop problems, refer to “Using the Configuration Utility diagnostics tools” on page 157.

**Table 61: Loop controller troubleshooting**

Problem	Possible cause
An open is detected on the loop	<ul style="list-style-type: none"> <li>The loop is incorrectly wired or a connector is loose</li> <li>A detector or isolator base is defective</li> <li>A conductor is broken</li> <li>A device is not installed on the loop</li> <li>A device is not defined in the VM-CU</li> </ul>
A short is detected on the loop	<ul style="list-style-type: none"> <li>The loop is incorrectly wired (often crossed wires on a device base)</li> <li>A detector, detector base, or module is defective</li> <li>There is a short circuit between loop wires</li> </ul>

<b>Problem</b>	<b>Possible cause</b>
A ground fault is detected on the loop	<ul style="list-style-type: none"> <li>• There is a pinched wire between a device and the electrical box</li> <li>• The loop wire is nicked and making contact with ground</li> </ul>
An internal trouble is detected on the loop	<ul style="list-style-type: none"> <li>• A detector is defective or dirty</li> <li>• A CO module is defective or not seated correctly</li> <li>• A photo or heat sensor is reading too high or too low</li> <li>• A light source is affecting a detector</li> <li>• A wiring terminal flange in the detector base is touching another terminal flange</li> <li>• An isolator or relay base is defective</li> <li>• Devices are drawing too much or too little current during mapping</li> </ul>
A maintenance alert is detected on the loop	A detector needs cleaned
The system reports an “End of life ACT” event	A CO module needs replacement

## Mapping errors

Table 62 lists basic mapping errors. For information on identifying and locating mapping errors, refer to “Using the Configuration Utility diagnostics tool” below.

**Note:** Do not replace factory-programmed devices such as pull stations and MM1 modules with a GSA-CT1.

**Table 62: Signaling line circuit mapping errors**

<b>Problem</b>	<b>Possible causes</b>
A mapping error is detected on the loop	<ul style="list-style-type: none"> <li>• There is a discrepancy between the expected map and the devices installed on the loop (serial number, personality code, or device type)</li> <li>• A device ID is incorrectly entered in the VM-CU</li> <li>• There are more than 124 T-taps on the loop</li> <li>• There is excessive circuit resistance</li> <li>• There is excessive circuit capacitance</li> </ul>
The system continues to remap the loop	<ul style="list-style-type: none"> <li>• An intermittent connection is causing one or more devices to lose then reestablish communication with the loop controller</li> <li>• There is a defective device or detector base</li> </ul>
There is a device type error	There is a discrepancy between the device type recorded on the internal map and the device installed on the loop

## Using the Configuration Utility diagnostics tools

The Configuration Utility contains a V-Series Status / Diagnostics tool that is used to assist the installing technician in isolating and correcting faults with the loop controller detectors and modules.

### Notes

- Try troubleshooting techniques described in “Understanding VM signaling line circuits” on page 146 *before* using the VM-CU tool.
- When using the VM-CU, press F1 at any time to open the Help topic for the page that you are currently viewing.

### To access the V-Series Status / Diagnostics tool:

1. Connect the computer running the VM-CU application to the panel that has the loop controller that is in trouble.
2. Configure the Remote Read Lock setting, if using an Ethernet connections (see “Using a TCP/IP connection to read from the panel” on page 54).
3. Open the VM-CU project, click Tools on the menu bar, select V-Series, and then click Status / Diagnostics.
4. From the V-Series Status / Diagnostics window, set the communication criteria.  
If using an RS-232 connection, the suggested baud rate is 19200.
5. From the Cabinet list, select the appropriate cabinet.
6. From the Loop Controller list, select the appropriate SLC1 loop controller.
7. From the Delay list, set the interval at which diagnostic updates will be received.
8. Select Connect.
9. Select each tab to view the diagnostic results.

## Loop controller diagnostics sequence

Table 63 lists the suggested VM-CU sequence for isolating problems on a signaling line circuit and problems with individual devices.

**Table 63: Suggested signaling line circuit diagnostics sequence**

<b>For loop faults, go to:</b>	<b>For VM device faults, go to:</b>
1. Mapping Errors tab	1. Device Troubles tab
2. Device Chains tab	2. Trouble Tables tab
3. Message Counters tab	

## Mapping errors diagnostics

Mapping errors prevent the system from successfully generating a signaling line circuit map.

Click the Mapping Errors tab to view information as to why the loop controller failed to successfully map the devices on the loop. Press F1 to open the Help topic, which provides instructions, descriptions, and troubleshooting tips for the information provided. Refer to Table 64 for suggested corrective actions.

**Table 64: Mapping errors diagnostics**

Error description	Suggested corrective action
The mapping command failed either because the sensor did not draw current or it was not possible to obtain stable mapping data from the loop	<ul style="list-style-type: none"> <li>• Verify that wiring is correct</li> <li>• Verify that devices are operational</li> <li>• Review the Chain Response and Device Response lists on the Device Chains tab to identify the failed devices</li> <li>• Check for loose wiring connections at the devices or T-taps</li> <li>• Check for faulty device(s)</li> </ul>
While mapping a chain from a device back to the loop controller, the chain was built with holes in it	<ul style="list-style-type: none"> <li>• Review the Chain Response and Device Response lists on the Device Chains tab to identify the failed devices</li> <li>• Compare the serial numbers in the Chain Response and Device Response lists on the Device Chains tab with the actual wiring to identify a conflict</li> </ul>
Map tables are inconsistent	<ul style="list-style-type: none"> <li>• Upload the current map</li> <li>• Compare the current map with the expected map</li> <li>• Write the map back to the loop controller</li> <li>• Ensure circuit wiring is correct</li> </ul>
The actual map does not match the stored expected map	<ul style="list-style-type: none"> <li>• Compare the current map with the expected map</li> <li>• Write the map back to the loop controller</li> <li>• Ensure loop wiring is correct</li> </ul>
Device address assignment failed	Review the serial number or address; if missing, replace the device
The map in use has invalid data (map supervision failure)	Wait for automatic map reconstruction to complete before continuing
Mapping supervision detected a change on the loop (a map rebuild was scheduled).	Wait for the automatic map reconstruction to complete continuing
Mapping supervision detected the device address or short address of the device being supervised changed (a map rebuild was scheduled)	Wait for automatic map reconstruction to complete before continuing
The mapping command failed because the sensor did not draw current, or it was not possible to obtain stable mapping data from the loop (a map rebuild was scheduled)	<ul style="list-style-type: none"> <li>• Wait for automatic map reconstruction to complete before continuing</li> <li>• Check for loose wiring</li> <li>• Check for a defective device</li> </ul>

Error description	Suggested corrective action
Mapping was aborted by an external event, such a new start on a device (a map rebuild was scheduled)	Wait for automatic map reconstruction to complete before continuing
Mapping supervision detected the device type of the device being supervised changed (a map fault was flagged)	<ul style="list-style-type: none"> <li>• Replace the device</li> <li>• Correct the loop controller programming</li> </ul>
Mapping aborted because a short or open was detected on the loop wiring	<ul style="list-style-type: none"> <li>• Check for an open or short on a Class A circuit</li> <li>• Check for a short across the entire Class B circuit</li> <li>• A reset may restart mapping</li> </ul>
Panel startup is not able to recreate the current map	Wait for automatic map reconstruction to complete before continuing
Assigning a short address to a device failed, possibly causing duplicate short addresses and mapping failures	<ul style="list-style-type: none"> <li>• Review the Chain Response and Device Response lists on the Device Chains tab to identify the failed device</li> <li>• Replace the device</li> <li>• Check for a wiring fault</li> </ul>
Mapping is disabled	Enable mapping
While mapping a chain from a device back to the loop controller, the chain appears to have two devices at the same location in the chain	<ul style="list-style-type: none"> <li>• Check for faulty wiring or a faulty device on the loop</li> <li>• Review the Chain Response and Device Response lists on the Device Chains tab to identify the conflict</li> </ul>
More than 125 end-of-line devices are detected on the loop	<ul style="list-style-type: none"> <li>• Correct the wiring</li> <li>• Remap the circuit</li> <li>• Reduce the number of T-taps</li> </ul>
While mapping a chain from a device back to the loop controller, a device displays past the end of the chain	<ul style="list-style-type: none"> <li>• Review the Device Chains list to identify the device</li> <li>• Compare the serial numbers or addresses with the actual wiring to identify the problem</li> </ul>
Mapping detected a difference between the device at the end-of-line and the devices in its chain	<ul style="list-style-type: none"> <li>• Review the Device Chains list to identify the conflict</li> <li>• Compare the serial numbers or addresses with the actual wiring to identify the conflict</li> </ul>

## Device chain diagnostics

A chain is a list of devices connected between the loop controller and a device being interrogated during circuit mapping. The chains and subchains created during the mapping process create a circuit map. If a circuit fails to map properly, investigate the devices making up chains and subchains to find the reason. Click the Device Chains tab to display a chain generated during the failed mapping process. Press F1 to open the Help topic that provides instructions and descriptions for the information provided.

Examine the chain and look for gaps within the address or serial number lists in a chain or subchain.

- Gaps in the list indicate areas that were not successfully mapped. A gap within the chain does not mean that the missing device has a problem; it means that the device was not successfully mapped.

- Compare the Chain Response and Device Response lists. All the devices on the Device Response list should also appear on the Chain Response list.
- Look for duplicate addresses or serial numbers on the same list.

Failure of a device to successfully map may be the result of a problem with another device, or wiring in a chain or subchain not directly connected to the unmapped device. Although the missing or duplicate devices are not always the cause of map failure, these devices should be examined for defects and wiring errors, and for duplicate entries in the VM-CU.

## Message counters diagnostics

During normal operation, the loop controller issues communication messages to the VM-1 devices on its loop. Message counters indicate how many times a communication message has been issued and the number of successful return messages. During normal operation, the percentage of messages received correctly should exceed 99%. Intermittent device or wiring problems are indicated by a low successful message rate. Click the Message Counters tab to check the signaling line circuit message error rate. Press F1 to open the Help topic that provides instructions and descriptions for the information provided.

Preventive measures can be taken by establishing a baseline of successful messages over a period time for each circuit. From the base line information, any changes from the norm can be quickly identified and corrected before a communication problem develops.

## Device troubles diagnostics

Each V-Series device is equipped with a 32-bit trouble register. Should a device's trouble bit be set at any time in the device's history, the device and the nature of the trouble will appear in the Latching Troubles By Device Address window. Click the Device Troubles tab to view a list of any devices with the latching trouble. Press F1 to open the Device Troubles Help topic that provides instructions and descriptions for the information provided.

Refer to Table 65 on page 161 and Table 66 on page 163 for a list of trouble messages, their possible causes, and possible solutions.

**Table 65: Detector device trouble messages**

<b>Device Trouble tab message</b>	<b>Possible cause</b>	<b>Possible solution</b>
External device line short	The detector is defective	Replace the detector
External device line open	The detector is defective	Replace the detector
Error XMIT light	The detector is dirty	Clean the detector
Device switched to short after isolator relay operated	A short is detected on the loop	Locate and remove the cause of the short
ESK value too low	<ul style="list-style-type: none"> <li>The detector is dirty</li> <li>The ion chamber is bad</li> </ul>	<ul style="list-style-type: none"> <li>Clean the detector</li> <li>Replace the detector</li> </ul>
ESK slope too high	<ul style="list-style-type: none"> <li>The detector is dirty</li> <li>The ion chamber is bad</li> </ul>	<ul style="list-style-type: none"> <li>Clean the detector</li> <li>Replace the detector</li> </ul>
ESK slope too low	<ul style="list-style-type: none"> <li>The detector is dirty</li> <li>The ion chamber is bad</li> </ul>	<ul style="list-style-type: none"> <li>Clean the detector</li> <li>Replace the detector</li> </ul>
Quiescent too large	Devices on the loop are drawing too much current during the mapping process	Place a temporary short across the data loop (approximately 5 seconds)
Quiescent too small	Devices on the loop are not drawing enough current during the mapping process	<ul style="list-style-type: none"> <li>Check for defective wiring</li> <li>Replace the device</li> </ul>
Short on relay base	The relay base is bad	Replace the relay base
External or isolator relay failure to switch	The base is bad	Replace the base
External or isolator relay switched	<ul style="list-style-type: none"> <li>The relay base is bad</li> <li>External electrical noise is present</li> </ul>	<ul style="list-style-type: none"> <li>Replace the relay base</li> <li>Remove or shield the noise source</li> </ul>
“O” value too small	The base is bad	Replace the base
Ion rate-of-rise too high	The ion chamber is bad	Replace the detector
Ion quiescent too high	The detector is dirty	Clean the detector
Ion quiescent too low	The detector is dirty	Clean the detector
Ion value too low	The detector is defective	Replace the detector
Thermal value too high	The base is bad	Replace the base
Thermal value too low	The base is bad	Replace the base
A/D converter fault	The A/D converter is defective	Replace the detector
EEPROM checksum error	The EEPROM is bad	Replace the detector
EEPROM write time out	The EEPROM is bad	Replace the detector
Unknown device type	The EEPROM is bad	Replace the detector
EEPROM write verify fault	The EEPROM is bad	Replace the detector
Ambient light too high	<ul style="list-style-type: none"> <li>The detector is dirty</li> <li>Outside light is reaching the detector chamber</li> </ul>	<ul style="list-style-type: none"> <li>Clean the detector</li> <li>Eliminate the light source</li> </ul>

<b>Device Trouble tab message</b>	<b>Possible cause</b>	<b>Possible solution</b>
Photo quiescent too high	The detector is dirty	Clean the detector
Photo quiescent too low	The detector is dirty	Clean the detector
Photo value too high	The base is bad	Replace the base
CO communication trouble UART	There is no communication between the V-Series detector and CO sensor.	Open the V-Series detector and make sure the CO module is properly seated.
CO sensor failure	The V-Series detector CO module failed supervision.	From the control panel, reset the panel. If the trouble recurs after 44 seconds replace the detector.
CO end of life	The V-Series detector CO module has reached its end of life.	Replace the CO module.
CO checksum failure	The V-Series detector CO module is not calibrated.	Replace the CO module.
Static value for vector measurement too big	Devices on the loop are drawing too much current during the mapping process.	Place a temporary short across the data loop (approximately 5 seconds).
Static value for vector measurement too small	Devices on the loop are not drawing enough current during mapping.	<ul style="list-style-type: none"> <li>• Replace the detector base.</li> <li>• Check for defective wiring.</li> </ul>
Short circuit on relay base	There is a short between the detector and detector base. (Note: The detector will report that it has a standard base, regardless of the real base type.)	Remove the short.
Device has switched to a short circuit while closing the isolator relay	There is a short on the loop. (Note: This only applies to detectors with an isolator base.)	Remove the short on the loop.
External or isolator relay does not switch	The base cannot change its state.	<p>Isolator base:</p> <ul style="list-style-type: none"> <li>• Remove the detector from the base for 60 seconds, and then put it back on the base. If the trouble returns or there is no power to the next base, replace the faulty base.</li> </ul> <p>Relay base:</p> <ul style="list-style-type: none"> <li>• Remove the detector from the base for 60 seconds, and then put it back on the base. If the trouble returns, replace the faulty base.</li> <li>• Smoke the detector while it is on the base. If after the alarm the trouble returns, replace the base.</li> </ul>
Error with EEPROM ID, EEPROM not initialized	<ul style="list-style-type: none"> <li>• The flash memory is corrupted.</li> <li>• The EEPROM is empty (the devices are not identified).</li> </ul>	Replace the detector.

Device Trouble tab message	Possible cause	Possible solution
In EEPROM data, non-existent device type	The detector is not a Signature detector.	Replace the detector.
Double failure by EEPROM Write Verify	The detector cannot write to the flash memory.	Replace the detector.

**Table 66: Module trouble messages**

Trouble message	Possible cause	Possible solution
Relay switched	The relay toggled from the actual state	<ul style="list-style-type: none"> <li>Manually reset the relay</li> <li>Replace the module</li> </ul>
Vector current too large	The devices on the loop are drawing too much current during the mapping procedure	Place a temporary short across the data loop (approximately 5 seconds)
Vector current too small	The devices on the loop are not drawing enough current during the mapping procedure	<ul style="list-style-type: none"> <li>Reduce the loop resistance</li> <li>Replace the base</li> <li>Check for defective wiring</li> </ul>
EEPROM not initialized	The EEPROM is not properly programmed	Replace the module
EEPROM write time out	The EEPROM is bad	Replace the module
A/D time out	The A/D converter is defective	Replace the module
EEPROM write verify fault	The EEPROM is defective	Replace the module
Line monitor trouble	The loop voltage is low	Check the loop
Class A trouble	A short or open is been detected on the input or output circuit	Check input/output wiring
RAM not programmed	The RAM is bad	Replace the module

## Trouble Tables diagnostics

Trouble Tables display multiple categories of active device troubles. The active troubles should be compared with a device's trouble history (Device Trouble tab) to determine any possible trouble pattern. Click the Trouble Tables tab to resolve device troubles. Press F1 to open the Trouble Tables Help topic that provides instructions and descriptions for the information provided.

Refer to Table 65 on page 161 and Table 66 above for a list of trouble messages, their possible causes and possible solutions.

## Signaling line circuit real-time statuses

The signaling line circuit status function is used to determine the real-time status of a loop. This function is useful in isolating and correcting faults on the loop.

Click the Current Status tab to display real-time data. Press F1 to open the Current Status Help topic that provides instructions and descriptions for the information provided.

### Displaying a status log of current events

Click the Status Log tab to show a real-time list of events that have occurred since the system last established a connection to the loop controller. Press F1 to open the Status Log Help topic that provides instructions and descriptions for the information provided.

### Displaying an in-progress chart

Click the Mapping Progress tab to show a real-time graph of the loop controller's progress through its initialization process. Press F1 to open the Mapping Progress Help topic that provides instructions and descriptions for the information provided.

## Using HyperTerminal to troubleshoot the system

HyperTerminal is a useful tool for gathering information from the control panel and for troubleshooting system faults through an RS-232 port connection. The information gathered can be saved as a plain text file (TXT extension) and submitted electronically to technical support for evaluation.

HyperTerminal comes with your Windows operating system as an installable option. HyperTerminal, if installed, is typically found on the Accessories menu (Start > Programs > Accessories > HyperTerminal).

### Setting up a HyperTerminal connection

Before you can gather information from the control panel, you must set up a HyperTerminal connection.

#### To set up a HyperTerminal connection:

**Note:** Requires a separately ordered programming cable, P/N 260097.

1. Start HyperTerminal.
2. In the Connection Description dialog box, type a name for the connection in the Name box, and then click OK.
3. In the Connect To dialog box, select the COM port you are using to connect your laptop computer to the control panel, and then click OK.
4. In the COM port's Properties dialog box, set the port settings as described below, and then click OK.
  - Bits per second: 9600
  - Data bits: 8
  - Parity: None
  - Stop bits: 1
  - Flow control: None
5. On the File menu, click Save to save your connection settings.
6. Connect one end of a DB-9 programming cable to the terminal block on the VM-CPU. See Figure 56.
7. Connect the other end of the cable to the RS-232 jack on the computer.

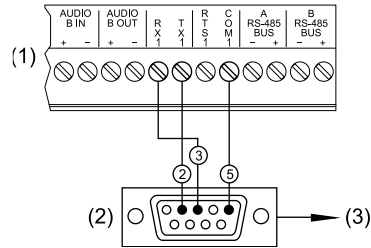
**Figure 56: RS-232 terminal block connections to the DB-9 programming cable**

- (1) VM-CPU terminal connector block
- (2) Rear view of female DB-9 connector
- (3) To the RS-232 jack of computer



# Appendix A

## System calculations

### Summary

This appendix provides instructions and worksheets for calculating wire lengths and sizing standby batteries.

### Content

Network data riser limits	168
Data network specifications	168
Cable properties	168
Calculating a maximum length	169
Calculating maximum wire capacitance per foot	169
Signaling line circuit wire length	170
Determine the maximum allowable branch length	170
Determining the total loop length	176
Notification appliance circuit calculations	177
Introduction	177
What you will need	177
Worksheet method	179
Equation method	180
25 or 70 VRMS NAC wire length	182
Cabinet battery	183
Battery calculations	184
Fiber optic cable worksheet	187

## Network data riser limits

Cumulative data network capacitance refers to the total capacitance of all copper wire used for the data riser. The cumulative capacitance of data networks must be within certain limits to permit stable network communications.

Audio networks are not affected by cumulative capacitance, due to the method of retransmitting data. The audio network retransmits data byte-by-byte, so the individual bit times of a byte are restored at each node in the network.

The data network retransmits data bit-by-bit. This method of retransmitting data restores the amplitude of a bit at each node, but any distortions in bit timing are passed through to the next node. Data network communication faults begin to occur at about 23% distortion of bit timing.

Cumulative data network capacitance induces bit timing distortion.

A fiber link in a data network electrically isolates two nodes, but distortions in bit timing are not restored by the fiber segment. Distortions in bit timing are passed through the fiber to the next node. The bit transition time of model VM-NOCF fiber cards is fast enough to be neglected in determining the maximum wire length that can be used in the data network.

## Data network specifications

Here are the maximum allowed values between any three nodes of a network.

- Resistance: 90 ohms ( )
- Capacitance: 0.3 microfarads ( $\mu\text{F}$ )
- Distance: 5,000 feet

The following table lists the maximum cumulative capacitance for the entire data network given various wire sizes and transmission rates. Maximum cumulative capacitance is the total capacitance of all installed copper wire used in the data network.

### Maximum cumulative capacitance in microfarads

Wire size (AWG)	At 38.4 Kbaud	At 19.2 Kbaud
18	1.4	2.8
16	1.8	3.6
14	2.1	4.2

## Cable properties

Data and audio networks in a VM-1 system do *not* require the use of shielded cable. Networks designed with twisted-pair can be about twice as long as those designed with shielded cable.

The maximum length of a data network varies with the properties of the wire used. Wire manufacturers typically provide specifications for wire resistance and capacitance.

Resistance is generally specified in ohms per 1,000 feet, and must be doubled for 1,000 feet of a twisted-pair cable. Capacitance is specified in picofarads per foot (pF/ft).

The capacitance between conductors of a twisted-pair is commonly referred to as *conductor-conductor* or *mutual* capacitance. Shielded cable has an additional capacitance between each conductor and the shield. The capacitance of either conductor to shield is typically twice the value of mutual capacitance, and the highest value of capacitance must be used when calculating the maximum length of a data network.

The overall length of data networks designed with twisted-pair cable is about twice as long as data networks designed with shielded cable due to the additional capacitance resulting from the shield.

## Calculating a maximum length

The maximum length of a data network can be calculated by dividing the maximum cumulative capacitance allowed by the highest capacitance rating of the selected cable.

For example, say you wanted to determine maximum length of a data network using 18 AWG cable that is rated at 25 pF per foot. The network will communicate at 38.4 Kbaud.

The maximum length equals the maximum cumulative capacitance divided by the capacitance per foot. In equation form:

$$ML = MCC / CPF$$

Where,

ML = Maximum length

MCC = Maximum cumulative capacitance

CPF = Capacitance per foot

In our example, the calculation is as follows:

$$ML = 1.4 \mu\text{F} / 25 \text{ pF/ft}$$

$$ML = 56,000 \text{ ft}$$

## Calculating maximum wire capacitance per foot

The capacitive property of twisted-pair cable varies and the cost of cable generally increases as the capacitance per foot decreases. Following is a sample calculation for determining the maximum capacitance per foot that a cable can have for a given network length.

The maximum capacitance per foot equals the maximum cumulative capacitance divided by the total network length. In equation form:

$$MCPF = MCC / TNL$$

Where,

MCC = Maximum cumulative capacitance, from the table given in this topic

TNL = Total network length, the sum of the lengths of individual copper runs in the network

For example, the total copper distance of a network is 26,000 feet. Calculate the maximum capacitance per foot that can be used for 18 AWG twisted-pair cable at 38.4K baud.

$$MCPF = MCC / TNL$$

$$MCPF = 1.4 \mu\text{F} / 26,000 \text{ ft}$$

$$MCPF = 53.8 \text{ pF/ft}$$

## Signaling line circuit wire length

Circuit resistance and capacitance determines the maximum length of a signaling line circuit. Circuit resistance affects the wire length of the longest circuit branch. Circuit capacitance affects the total amount of wire that can be used on the circuit.

### Notes

- The design of the signaling line circuit must not exceed either of the two measurements.
- There are no restrictions placed on the wiring used for the signaling line circuit. Longer wire runs may be obtained using standard (non-twisted, non-shielded) wire pairs.

### Determine the maximum allowable branch length

The maximum branch length is the wire distance measured from the loop controller to the last device on the longest circuit path as shown below.

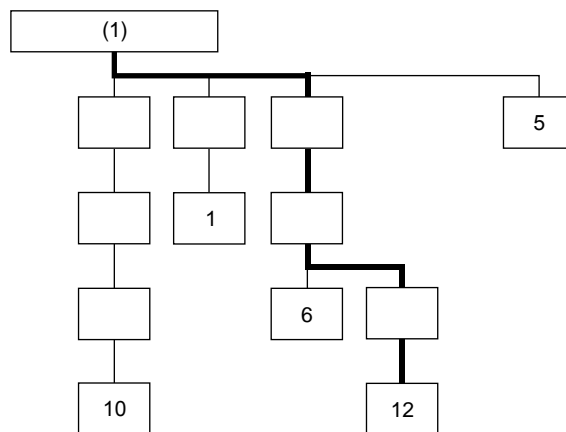

(1) Loop controller

Several factors influence the maximum allowable branch length:

- Wire gauge and type
- Number of GSA detectors and modules installed on the branch
- Number of GSA-UMs or GSA-MABs configured for two-wire smoke detectors installed on the branch

Table 67 on page 172 through Table 70 on page 175 provide the maximum allowable branch length for any detector, module, GSA-UM, and GSA-MAB and the wire gauge combination. Using the wire distances specified in the tables ensures that the circuit does not exceed the maximum circuit resistance of the signaling line circuit.

**Note:** To calculate the wire distance with respect to circuit resistance, the tables assume that the circuit is end-loaded (all devices are clustered more towards the end of the circuit) and the circuit uses standard non-shielded wire.

**To determine the maximum allowable length of a signaling line circuit branch:**

1. Identify the device located farthest from the loop controller.
2. Determine the number of detectors, modules, and GSA-UMs or GSA-MABs configured for two-wire smokes that lie on the same conductive path between the device identified in step 1 and the loop controller.
3. Calculate the number of detector and module addresses. Some modules require two addresses.
4. Determine the size of the wire used to construct the loop.
5. Find the maximum allowable wire distance for the longest branch in the lookup tables as follows:

If no GSA-UMs or GSA-MABs are installed, use Table 67 on page 172.

If 1 to 5 GSA-UMs GSA-MABs are installed, use Table 68 on page 173.

If 6 to 10 GSA-UMs or GSA-MABs are installed, use Table 69 on page 174.

If 11 to 15 GSA-UMs or GSA-MABs are installed, use Table 70 on page 175.

**Table 67: Maximum branch length with zero GSA-UMs/GSA-MABs configured for two-wire smokes**

Detector addresses	Module addresses	Maximum allowable wire distance using non-twisted, non-shielded wire pairs					
		18 AWG		16 AWG		14 AWG	
		ft	m	ft	m	ft	m
1–25	0	7437	2267	11815	3601	18792	5728
26–50	0	7038	2145	11180	3408	17782	5420
51–75	0	6638	2023	10545	3214	16772	5112
76–100	0	6238	1901	9910	3021	15762	4804
101–125	0	5839	1780	9275	2827	14752	4497
0	1–25	7267	2215	11544	3519	18361	5597
1–25	1–25	6867	2093	10909	3325	17351	5289
26–50	1–25	6467	1971	10275	3132	16342	4981
51–75	1–25	6068	1849	9640	2938	15332	4673
76–100	1–25	5668	1728	9005	2745	14322	4365
101–125	1–25	5268	1606	8370	2551	13312	4057
0	26–50	6697	2041	10639	3243	16921	5157
1–25	26–50	6297	1919	10004	3049	15911	4850
26–50	26–50	5897	1798	9369	2856	14901	4542
51–75	26–50	5498	1676	8734	2662	13891	4234
76–100	26–50	5098	1554	8099	2469	12881	3926
101–125	26–50	4698	1432	7464	2275	11871	3618
0	51–75	5906	1800	9383	2860	14923	4549
1–25	51–75	5250	1600	8340	2542	13265	4043
26–50	51–75	4633	1412	7360	2243	11707	3568
51–75	51–75	4051	1235	6435	1961	10235	3120
76–100	51–75	3498	1066	5558	1694	8839	2694
101–125	51–75	2973	906	4723	1440	7512	2290
0	76–100	3931	1198	6245	1903	9932	3027
1–25	76–100	3404	1037	5407	1648	8601	2621
26–50	76–100	2899	883	4605	1404	7324	2232
51–75	76–100	2413	735	3833	1168	6096	1858
76–100	76–100	1945	593	3089	942	4913	1498
101–125	76–100	1493	455	2371	723	3771	1149
0	101–125	2631	802	4180	1274	6649	2027
1–25	101–125	2165	660	3439	1048	5470	1667
26–50	101–125	1713	522	2721	829	4328	1319
51–75	101–125	1274	388	2023	617	3218	981
76–100	101–125	847	258	1345	410	2140	652
101–125	101–125	431	131	685	209	1089	332

**Table 68: Maximum branch length with 1 to 5 GSA-UMs/GSA-MABs configured for two-wire smokes**

Detector addresses	Module addresses	Maximum allowable wire distance using non-twisted, non-shielded wire pairs					
		18 AWG		16 AWG		14 AWG	
		ft	m	ft	m	ft	m
1-25	0	6778	2066	10768	3282	17126	5220
26-50	0	6131	1869	9741	2969	15492	4722
51-75	0	5501	1677	8739	2664	13899	4236
76-100	0	4885	1489	7760	2365	12342	3762
101-125	0	4282	1305	6802	2073	10819	3298
0	1-25	5353	1632	8504	2592	13525	4122
1-25	1-25	4720	1439	7498	2286	11926	3635
26-50	1-25	4100	1250	6513	1985	10359	3157
51-75	1-25	3491	1064	5546	1691	8821	2689
76-100	1-25	2893	882	4597	1401	7311	2228
101-125	1-25	2306	703	3663	1116	5826	1776
0	26-50	3776	1151	5999	1829	9542	2908
1-25	26-50	3153	961	5009	1527	7966	2428
26-50	26-50	2539	774	4034	1230	6416	1956
51-75	26-50	1935	590	3075	937	4890	1491
76-100	26-50	1340	409	2130	649	3387	1032
101-125	26-50	754	230	1197	365	1905	581
0	51-75	2491	759	3957	1206	6293	1918
1-25	51-75	1868	569	2967	904	4720	1439
26-50	51-75	1254	382	1992	607	3168	966
51-75	51-75	648	198	1030	314	1638	499
76-100	51-75	50	15	80	24	126	39
101-125	51-75						
0	76-100	1386	422	2201	671	3501	1067
1-25	76-100	760	232	1208	368	1921	586
26-50	76-100	143	44	227	69	361	110
51-75	76-100						
76-100	76-100						
101-125	76-100						
0	101-125						
1-25	101-125						
26-50	101-125						
51-75	101-125						
76-100	101-125						
101-125	101-125						

**Table 69: Maximum branch length with 6 to 10 GSA-UMs/GSA-MABs configured for two-wire smokes**

Detector addresses	Module addresses	Maximum allowable wire distance using non-twisted, non-shielded wire pairs					
		18 AWG		16 AWG		14 AWG	
		ft	m	ft	m	ft	m
1-25	0	5045	1538	8015	2443	12748	3886
26-50	0	4494	1370	7139	2176	11355	3461
51-75	0	3950	1204	6275	1913	9981	3042
76-100	0	3414	1040	5423	1653	8625	2629
101-125	0	2884	879	4581	1396	7286	2221
0	1-25	4106	1252	6523	1988	10375	3162
1-25	1-25	3542	1080	5627	1715	8950	2728
26-50	1-25	2985	910	4742	1445	7542	2299
51-75	1-25	2435	742	3868	1179	6152	1875
76-100	1-25	1891	576	3004	916	4778	1456
101-125	1-25	1353	412	2150	655	3419	1042
0	26-50	2869	874	4557	1389	7248	2209
1-25	26-50	2296	700	3648	1112	5802	1768
26-50	26-50	1730	527	2749	838	4372	1332
51-75	26-50	1170	357	1859	567	2957	901
76-100	26-50	617	188	979	299	1558	475
101-125	26-50	68	21	108	33	172	53
0	51-75	1796	547	2853	869	4537	1383
1-25	51-75	1214	370	1929	588	3067	935
26-50	51-75	638	195	1014	309	1613	492
51-75	51-75	69	21	109	33	173	53
76-100	51-75						
101-125	51-75						
0	76-100	833	254	1323	403	2105	642
1-25	76-100	242	74	385	117	613	187
26-50	76-100						
51-75	76-100						
76-100	76-100						
101-125	76-100						
0	101-125						
1-25	101-125						
26-50	101-125						
51-75	101-125						
76-100	101-125						
101-125	101-125						

**Table 70: Maximum branch length with 11 to 15 GSA-UMs/GSA-MABs configured for two-wire smokes**

Detector addresses	Module addresses	Maximum allowable wire distance using non-twisted, non-shielded wire pairs					
		18 AWG		16 AWG		14 AWG	
		ft	m	ft	m	ft	m
1–25	0	3931	1198	6245	1904	9932	3028
26–50	0	3427	1045	5444	1660	8659	2640
51–75	0	2928	893	4651	1418	7397	2255
76–100	0	2432	741	3864	1178	6145	1873
101–125	0	1941	592	3083	940	4903	1495
0	1–25	3247	990	5158	1572	8204	2501
1–25	1–25	2722	830	4324	1318	6878	2097
26–50	1–25	2202	671	3498	1066	5563	1696
51–75	1–25	1686	514	2678	816	4259	1298
76–100	1–25	1174	358	1865	569	2966	904
101–125	1–25	666	203	1058	323	1683	513
0	26–50	2204	672	3502	1067	5570	1698
1–25	26–50	1664	507	2644	806	4205	1282
26–50	26–50	1129	344	1793	547	2852	870
51–75	26–50	598	182	950	290	1511	461
76–100	26–50	71	22	113	34	179	55
101–125	26–50						
0	51–75	1263	385	2007	612	3192	973
1–25	51–75	710	216	1128	344	1794	547
26–50	51–75	161	49	256	78	407	124
51–75	51–75						
76–100	51–75						
101–125	51–75						
0	76–100						
1–25	76–100						
26–50	76–100						
51–75	76–100						
76–100	76–100						
101–125	76–100						
0	101–125						
1–25	101–125						
26–50	101–125						
51–75	101–125						
76–100	101–125						
101–125	101–125						

## Determining the total loop length

The total loop length is the sum of the lengths of all the wire segments installed in the data circuit.

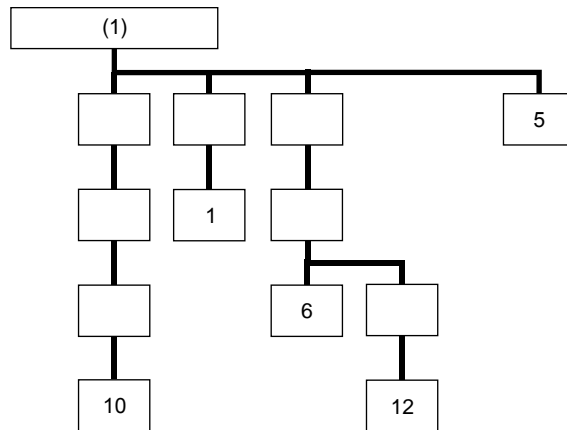

(1) Loop controller

The total length of all the cable installed in the signaling line circuit cannot exceed the values listed below:

**Table 71: Maximum signaling signal circuit cable length**

Wire type	Wire Size		
	14 AWG	16 AWG	18 AWG
Twisted pair	13,157 ft (4,010 m)	13,888 ft (4,233 m)	20,000 ft (6,096 m)
Twisted-shielded pair	5,952 ft (1,814 m)	6,098 ft (1,859 m)	8,621 ft (2,628 m)
Non-twisted, non-shielded pair	20,000 ft (6,096 m)	20,000 ft (6,096 m)	20,000 ft (6,096 m)

If the cable manufacturer’s data indicates the capacitance per foot of the cable, the following method may be used to determine the maximum total loop length.

**Note:** In no case may the total loop length of a signaling line circuit exceed 20,000 feet (6,098 meters).

$$L_{max} = 500,000 / C_{pf}$$

Where,

- $L_{max}$  = maximum total cable length in feet
- $C_{pf}$  = Cable capacitance in picofarads per foot

**Note:** A short circuit on a signaling line circuit can disable the entire circuit. In order to limit the effect of a single short circuit, GSA-IB Isolator Bases or GSA-IM Isolator modules can be installed at strategic points in the circuit.

# Notification appliance circuit calculations

## Introduction

This topic shows you how to determine the maximum cable length of a notification appliance circuit for a given number of appliances.

Two methods are presented: worksheet and equation. The worksheet method is simpler, but your installation must meet the criteria listed on the worksheet. If your installation does not meet these criteria, you need to use the equation method.

The methods given here determine cable lengths that work under all operating conditions. The calculations ensure that the required operating voltage and current will be supplied to all notification appliances. To do this, we assume these two worst-case conditions:

- The voltage at the NAC terminals is the minimum provided by the power supply
- The notification appliances are clustered at the end of the NAC cable

Other, more detailed methods that distribute the appliance load along the NAC cable may indicate that longer cable runs are possible.

## What you will need

### Appliance and cable values

Whether you use the worksheet method or the equation method, you will need to know the following:

- The minimum operating voltage required for the appliances
- The maximum operating current drawn by each appliance
- The resistance per unit length of the wire used (  $\Omega$ /ft)

This information can be found on the appliance installation sheets and on the cable specification sheet.

### Power supply values

For either method, you will need some fixed or calculated operating values for your specific power supply. The fixed values are:

- Maximum voltage = 26.4 V
- Source voltage = 22.4 V
- Load factor = 0.0 V/A
- Power type = DC

**Note:** The PS10-4B has an onboard boost circuit to keep battery voltage at a required value. If the battery voltage drops below the required value, the boost circuit activates.

The *maximum voltage* is the highest voltage measured at the NAC terminals. This value is not used in the calculations, but is given so you can ensure appliance compatibility.

The *source voltage* is the theoretical operating minimum for the NAC source, and is calculated as 85% of 24 volts [minus the diode drop].

The *load factor* is a measure of how the power supply voltage reacts when a load is applied. The load factor measures the voltage drop per ampere of current drawn by the load.

The *power type* reflects the type of power supplied to the NAC terminals at minimum voltage. The current draw of notification appliances can vary substantially with the type of power supplied: full-wave rectified (VFWR) or direct current (VDC). It is important to know the power type at minimum terminal voltage.

You will need to calculate the following values relating to your power supply and to the NAC circuit current. These are:

- Minimum voltage
- Voltage drop

The *minimum voltage* is the lowest voltage measured at the NAC terminals when the power supply is under the maximum load for that circuit (i.e. for the appliances that constitute the NAC).

The *voltage drop* is the difference between the minimum voltage and 16 V. This value is for use with the worksheet only.

## Worksheet method

Use this worksheet to determine the maximum cable length of a notification appliance circuit for a given number of appliances.

Use this worksheet only if all the appliances are regulated. That is, they must have a minimum operating voltage of 16 V. For other appliances, use the “Equation method.”

### Worksheet 1: NAC cable length

		[NAC1 or Source 1]	[NAC2 or Source 2]	[NAC3 or Source 3]	[NAC4 or Source 4]	
Total operating current [1]		<input type="text"/>	<input type="text"/>	<input type="text"/>	<input type="text"/>	A
Load factor	×	<input type="text" value="0.0"/>	<input type="text" value="0.0"/>	<input type="text" value="0.0"/>	<input type="text" value="0.0"/>	V/A
Load voltage drop	=	<input type="text"/>	<input type="text"/>	<input type="text"/>	<input type="text"/>	V
Source voltage		<input type="text" value="22.4"/>	<input type="text" value="22.4"/>	<input type="text" value="22.4"/>	<input type="text" value="22.4"/>	V
Load voltage drop	–	<input type="text"/>	<input type="text"/>	<input type="text"/>	<input type="text"/>	V
Minimum voltage	=	<input type="text"/>	<input type="text"/>	<input type="text"/>	<input type="text"/>	V
Regulated appliance voltage	–	<input type="text" value="16.0"/>	<input type="text" value="16.0"/>	<input type="text" value="16.0"/>	<input type="text" value="16.0"/>	V
Voltage drop [2]	=	<input type="text"/>	<input type="text"/>	<input type="text"/>	<input type="text"/>	V
Total operating current	÷	<input type="text"/>	<input type="text"/>	<input type="text"/>	<input type="text"/>	A
Maximum resistance	=	<input type="text"/>	<input type="text"/>	<input type="text"/>	<input type="text"/>	
Wire resistance ( /ft) [3]	÷	<input type="text"/>	<input type="text"/>	<input type="text"/>	<input type="text"/>	
Maximum wire length	=	<input type="text"/>	<input type="text"/>	<input type="text"/>	<input type="text"/>	ft
	÷	<input type="text" value="2"/>	<input type="text" value="2"/>	<input type="text" value="2"/>	<input type="text" value="2"/>	
<b>Maximum cable length</b>	=	<input type="text"/>	<input type="text"/>	<input type="text"/>	<input type="text"/>	ft

[1] Total of the maximum operating currents for all appliances as specified for DC power. See the appliance installation sheets for operating currents.

[2] This voltage drop is valid for regulated notification appliances only. For special application appliances, see “Equation method” on page 180.

[3] Use the manufacturer’s published wire resistance expressed in ohms per foot. For typical values, see Table 72 on page 180, later in this topic.

## Equation method

### Appliance operating voltage and current

Regulated notification appliances have an operating range from 16 V to 33 V. Use 16 V as the minimum appliance voltage when using regulated notification appliances.

When using special application appliances, refer to the installation sheets to determine the minimum appliance voltage required.

What if there are different types of appliances in the NAC, and each type has a different minimum operating voltage? In this case, use the *highest* minimum voltage required by any appliance.

The total current requirement for the appliances will be the sum of the individual maximum currents drawn by each appliance when using DC power. Use the maximum current for the appliance over the 16 V to 33 V range.

If all appliances draw the same maximum current, the total current is the maximum current multiplied by the number of appliances. If different appliance types have different maximum currents, the total current is the sum of the maximum current for each appliance type multiplied by the number of appliances of that type.

### Wire resistance

Typical wire resistances are shown in the following table.

**Table 72: Typical wire resistances**

Wire gauge (AWG)	Resistance 1-strand uncoated copper		Resistance 7-strand uncoated copper	
	per foot	per meter	per foot	per meter
12	0.00193	0.00633	0.00198	0.00649
14	0.00307	0.01007	0.00314	0.01030
16	0.00489	0.01604	0.00499	0.01637
18	0.00777	0.02549	0.00795	0.02608

When performing these calculations, always refer to the actual cable supplier documentation and use the actual /ft (or /m) for the cable being used.

### Calculating cable length

To calculate the maximum CAB cable length:

1. Calculate the total current ( $I_{tot}$ ) as the sum of the maximum operating currents for all the appliances.

$$I_{tot} = \sum I_a$$

Where:

$I_a$  = appliance maximum current

Refer to the appliance installation sheets for  $I_a$ . Remember to use the maximum operating current specified for DC power.

2. Calculate the minimum voltage ( $V_m$ ).

$$V_m = V_r - (I_{tot} \times K)$$

Where:

$V_r$  = source voltage

$I_{tot}$  = total current (from above)

$K$  = load factor

For the power supply,  $V_r$  is 22.4 V and  $K$  is 0.0 V/A.

3. Calculate the allowable voltage drop ( $V_d$ ) between the NAC circuit source and the appliances.

$$V_d = V_m - V_a$$

Where:

$V_m$  = minimum voltage (from above)

$V_a$  = appliance minimum voltage

For regulated notification appliances,  $V_a$  is 16 V. For special application appliances,  $V_a$  is the lowest operating voltage specified on the appliance installation sheet.

4. Calculate the maximum resistance ( $R_{max}$ ) the wire can have.

$$R_{max} = V_d / I_{tot}$$

Where:

$V_d$  = voltage drop

$I_{tot}$  = total current

5. Calculate the maximum length of the cable ( $L_c$ ), based on the maximum resistance allowed, the resistance of the wire, and the number of wires in the cable (two).

$$L_c = (R_{max} / R_w) / 2$$

Where:

$R_{max}$  = maximum resistance

$R_w$  = wire resistance factor

Example: You're using regulated notification appliances. Assume that the maximum operating current for each appliance is 100 mA for [DC or FWR] power, and that 20 appliances will be placed on the NAC. The cable is 12 AWG wire, and the manufacturer specifies a wire resistance factor of 0.002 /ft

$$I_{tot} = \sum I_a$$

$$= 20 \times 0.1 \text{ A}$$

$$= 2 \text{ A}$$

$$V_m = V_r - (I_{tot} \times K)$$

$$= 22.4 \text{ V} - (2 \text{ A} \times 0.0 \text{ V/A})$$

$$= 22.4 \text{ V} - 0.0 \text{ V}$$

$$= 22.4 \text{ V}$$

$$V_d = V_m - V_a$$

$$= 22.4 \text{ V} - 16.0 \text{ V}$$

$$= 6.4 \text{ V}$$

$$R_{max} = V_d / I_{tot}$$

$$= 6.4 \text{ V} / 2.0 \text{ A}$$

$$= 3.2$$

$$L_c = (R_{max} / R_w) / 2$$

$$= (3.2 / 0.002 / \text{ft}) / 2$$

$$= 1600.0 \text{ ft} / 2$$

$$= 800.0 \text{ ft}$$

So the maximum wire run for this NAC would be 800 ft (rounding down for safety).

## 25 or 70 VRMS NAC wire length

The maximum allowable wire length is the farthest distance that a pair of wires can extend from the amplifier to the last speaker on the notification appliance circuit without losing more than 0.5 dB of signal. Calculating the maximum allowable wire length using this method ensures that each speaker operates at its full potential.

Several factors influence the maximum allowable wire length:

- Wire size
- Output signal level of the amplifier driving the circuit
- Number of speakers installed on the circuit

To calculate the maximum allowable wire length for a 0.5 dB loss, use the following formula:

$$\text{Maximum length} = (59.25 \times \text{Amplifier output}^2) / (\text{Wire resistance} \times \text{circuit load})$$

Where,

- Amplifier output is the signal level in VRMS supplied by the amplifier driving the circuit
- Circuit load is the total watts required by the audio circuit
- Wire resistance is the resistance rating of the wire per 1000 ft pair. See Table 73.

For example, the maximum allowable wire length for an audio circuit consisting of a 30 W, 25 VRMS amplifier driving thirty 1 watt speakers, using 18-gauge wire would be 95 ft

$$94.95 = (59.25 \times 25^2) / (13 \times 30)$$

**Table 73: Wire resistance ratings**

Wire Size	Resistance per 1,000 ft pair (ohms)
18 AWG (0.75 sq mm)	13.0
16 AWG (1.0 sq mm)	8.0
14 AWG (1.50 sq mm)	5.2
12 AWG (2.5 sq mm)	3.2

Table 74 and Table 75 give the maximum allowable wire lengths for various wire sizes and loads. Use Table 74 when designing circuits for amplifiers set for 25 VRMS output. Use Table 75 when designing circuits for amplifiers set for a 70 VRMS output.

**Table 74: Maximum allowable length at 25 VRMS, 0.5 dB loss**

Wire size	Circuit load requirement											
	15 W		20 W		30 W		40 W		95 W		120 W	
	ft	m	ft	m	ft	m	ft	m	ft	m	ft	m
18 AWG (0.75 sq mm)	190	58	142	43	95	29	71	22	Over max current limit		Over max current limit	
16 AWG (1.0 sq mm)	309	94	231	70	154	47	116	35	48.7	15	39	12
14 AWG (1.5 sq mm)	475	145	356	109	237	72	178	54	75	23	59	18
12 AWG (2.5 sq mm)	772	235	579	176	386	118	289	88	121.8	37	96	29

**Table 75: Maximum allowable length at 70 VRMS, 0.5 dB loss**

Wire size	Circuit load requirement											
	15 W		20 W		30 W		40 W		95 W		120 W	
	ft	m	ft	m	ft	m	ft	m	ft	m	ft	m
18 AWG (0.75 sq mm)	1489	454	1117	340	744	227	558	170	235	72	186	57
16 AWG (1.0 sq mm)	2420	738	1815	553	1210	369	907	276	382	116	302	92
14 AWG (1.5 sq mm)	3722	1134	2792	851	1861	567	1396	426	588.7	180	465	142
12 AWG (2.5 sq mm)	6049	1844	4537	1383	3024	922	2268	691	955	291	756	230

## Cabinet battery

Use the following method to calculate the minimum ampere-hour capacity of a battery required in order to operate a panel in the absence of AC power. Battery calculations must be performed separately for each cabinet in the system.

Determine the total amount of current in milliamps required by all of the components that derive power from the battery while the panel is in standby mode. Multiply the total amount of standby current by the number of hours that the panel is required to operate in standby mode while on battery power.

Determine the total amount of current in milliamps required by all of the components that derive power from the battery while the panel is in alarm mode. Multiply the total amount of alarm current by the number of minutes that the panel is required to operate in alarm mode while on battery power. Divide the result by 60 to convert minutes to hours.

Add the total amount of standby current and the total amount of alarm current then divide the result by 1000 to convert to ampere-hours. Multiply this number by 1.2 to add a 20% safety factor to the calculations.

## Battery calculations

### Battery capacity worksheet

Instructions: Enter the standby and alarm currents from the other worksheets, and then calculate the size of standby batteries you need based on your operating time requirements.

	Standby current (mA)	Alarm current (mA)	CO alarm current (mA)
Total control panel current (from Worksheet A)	<input type="text"/>	<input type="text"/>	0
Total NAC current (from Worksheet B)	0	<input type="text"/>	0
Total AUX current (from Worksheet C)	<input type="text"/>	<input type="text"/>	0
Total CO alarm current (from Worksheet D)	0	0	<input type="text"/>
Smoke power [1]	<input type="text"/>	<input type="text"/>	0
<b>Total current</b>	<input style="border: 2px solid black;" type="text"/>	<input style="border: 2px solid black;" type="text"/>	<input style="border: 2px solid black;" type="text"/>
Operating time required	x <input type="text"/> h	x <input type="text"/> min	x <input type="text"/> 12 h
	<hr/>	<hr/>	<hr/>
		÷ 60	+12 h
	<hr/>	<hr/>	<hr/>
	+	+	= <input type="text"/> mAh
			× 1.2 [2]
			<input type="text"/> mAh
			÷ 1,000
			<input style="border: 2px solid black;" type="text"/> Ah

[1] A maximum of fifteen GSA-UM or GSA-MAB modules per signaling line circuit can be configured to support two-wire smoke detectors (personality codes 13, 14, 20, and 21). For standby current, enter 2.0 mA for each smoke power circuit used. For alarm current, enter 17.0 mA for each smoke power circuit used.

[2] Required 20% safety margin.

**Worksheet A: Control panel current**

**Instructions:** Enter the number of option cards installed in the control panel under Quantity, then calculate the standby and alarm currents using the values below, and then calculate the total at the bottom.

Devices	Qty	Standby current (mA)	Alarm current (mA)	Qty x Standby current (mA)	Qty x Alarm current (mA)
Base panel [1]	1	381.0	481.0	381.0	481.0
D12LS-VM [2]	<input type="text"/>	11.0	11.0	<input type="text"/>	<input type="text"/>
VM-SLC or VM-SLC-HC [3]	<input type="text"/>	120.0	132.0	<input type="text"/>	<input type="text"/>
VM-NOC	<input type="text"/>	98.0	98.0	<input type="text"/>	<input type="text"/>
VM-NOCF [4]	<input type="text"/>	105.0	105.0	<input type="text"/>	<input type="text"/>
VM-ETH1, VM-ETH2, or VM-ETH3	<input type="text"/>	42.0	54.0	<input type="text"/>	<input type="text"/>
CLA-PS10	<input type="text"/>	2.0	2.0	<input type="text"/>	<input type="text"/>
VM-PMI [5]	<input type="text"/>	23.0	29.0	<input type="text"/>	<input type="text"/>
ACHS	<input type="text"/>	47.0	64.0	<input type="text"/>	<input type="text"/>
VM-MFK [6]	<input type="text"/>	37.0	39.0	<input type="text"/>	<input type="text"/>
VM-DACT	<input type="text"/>	60.0	95.0	<input type="text"/>	<input type="text"/>
VM-SLCXB [7]	<input type="text"/>	144.0	204.0	<input type="text"/>	<input type="text"/>
24DC12 [8]	<input type="text"/>	8.0	750.0	<input type="text"/>	<input type="text"/>
<b>Totals (mA)</b>				<input type="text"/>	<input type="text"/>

[1] Includes the PS10-4B, the VM-CPU, one preinstalled VM-SLC or VM-SLC-HC card with a fully loaded loop circuit, and a VM-LCD.

[2] Add 2.5 mA for each active LED. Total current does not exceed 58 mA with all LEDs on.

[3] Standby and alarm current values are for one VM-SLC or VM-SLC-HC card with a fully loaded loop circuit. Increase the device quantity if you add a VM-SLC or VM-SLC-HC card to the VM-CPU or VM-SLCXB. The maximum quantity is two.

[4] Add 71.2 mA for each SMXLO2, 76.8 mA for each SMXHI2, and 20.0 mA for each MMXVR.

[5] Includes EAEC card currents.

[6] Includes telephone controller card and hook-switch card currents.

[7] Standby and alarm current values are for one preinstalled VM-SLC or VM-SLC-HC card with a fully loaded loop circuit. If you add a second VM-SLC or VM-SLC-HC card to this dual loop module, increase the card device quantity.

[8] Standby and alarm current values are for a 24DC12 without connected devices. Increase the values when you connect a device. Refer to the device installation sheet for its current values.

**Worksheet B: NAC power current**

**Instructions:** For each NAC/AUX circuit used to provide NAC power, enter the total amount of alarm current required. Use the DC RMS current values listed on the device's installation sheet for your calculations.

Devices	Standby current (mA)	Alarm current (mA)
NAC/AUX 1	<input type="text"/>	<input type="text"/>
NAC/AUX 2	<input type="text"/>	<input type="text"/>
NAC/AUX 3	<input type="text"/>	<input type="text"/>
NAC/AUX 4	<input type="text"/>	<input type="text"/>
<b>Total (mA)</b>	<input type="text"/>	<input type="text"/>

**Worksheet C: AUX power current load**

**Instructions:** For each NAC/AUX circuit used to provide AUX power, enter the total amount of standby and alarm currents required by the devices powered by the circuit. Use the standby and alarm currents on the device's installation sheet for your calculations.

Devices	Standby current (mA)	Alarm current (mA)
NAC/AUX 1	<input type="text"/>	<input type="text"/>
NAC/AUX 2	<input type="text"/>	<input type="text"/>
NAC/AUX 3	<input type="text"/>	<input type="text"/>
NAC/AUX 4	<input type="text"/>	<input type="text"/>
VM-CPU Main Board	<input type="text"/>	<input type="text"/>
RPM module [1]	<input type="text"/>	<input type="text"/>
GSA-REL module [1][2]	<input type="text"/>	<input type="text"/>
SIGA-AA30 amplifier [3]	<input type="text"/>	<input type="text"/>
SIGA-AA50 amplifier [3]	<input type="text"/>	<input type="text"/>
CDR-3 module [1]	<input type="text"/>	<input type="text"/>
IOP3A [1]	<input type="text"/>	<input type="text"/>
<b>Total (mA)</b>	<input type="text"/>	<input type="text"/>

[1] Do not include currents if the module *is not* installed.

[2] A maximum of ten GSA-REL modules per signaling line circuit can be installed.

[3] Do not include currents if the SIGA-AA30/50 amplifier (installed in an external cabinet) is not power by the VM-1 fire alarm control panel PS10-4B power supply.





# Appendix B

# Addresses

## Summary

This appendix provides a list of fire alarm system device addresses.

## Content

Address formats 190  
Card numbering 190  
Hardware layer device addresses 192  
Operator layer device address 193  
Remote annunciator device addresses 194  
Logic group addresses 202

## Address formats

VM-1 addresses are in PPCCDDDD format, where:

- PP is the cabinet number. Possible values are 01 (single panel systems) or 01 to 08 (networked systems).
- CC is the card number. Possible values are listed in Table 76.
- DDDD is the device number. Possible values are listed in Table 77, Table 78, and Table 79.

## Card numbering

Cards have a physical address and a logical address. The physical address identifies the card's location in the panel. The logical address identifies the card in the CPU database. See Table 76 and Figure 57 on page 191.

**Table 76: VM-1 card numbering**

	VM-PMI and VM-MFK	VM-PMI only	AMK-RN only
Card or circuit	Logical addresses		
VM-CPU Main Board	00	00	00
VM-LCD User Interface	00	00	00
PS10-4B Power Supply	02	02	02
Loop controller on the VM-CPU	03	03	03
Display modules	35	35	35
VM-DACT Dual Line Dialer Card [1]	05	05	05
VM-SLCXB Signaling Line Loop Controller Expansion Card [1]	05	05	05
Remote annunciator interface	04	04	04
VM-PMI Paging Microphone Interface	06	06	N/A
VM-MFK Firefighters Telephone	07	N/A	N/A
1st ACHS card [2]	08	07	06
2nd ACHS card [2]	09	08	07
3rd ACHS card [2]	10	09	08

[1] Either a VM-DACT card *or* a VM-SLCXB module can be installed in the slot.

[2] ACHS card logical address values vary depending on whether the VM-PMI and VM-MFK are installed. The AMK-RN does not have a logical address.



## Hardware layer device addresses

Table 77 lists the device addresses for points on the VM-1 hardware layer.

**Table 77: VM-1 hardware layer device addresses**

Card	Device or circuit	Address
PS10-4B	NAC/AUX 1 NAC/AUX 2 NAC/AUX 3 NAC/AUX 4	PP020001 PP020002 PP020003 PP020004
VM-CPU Loop Circuit 1  Loop Circuit 2	Detectors Modules Detectors Modules	PP030001 to PP030125 PP030126 to PP030250 PP030251 to PP030375 PP030376 to PP030500
VM-SLCXB Loop 1  Loop 2	Detectors Modules Detectors Modules	PP050001 to PP050125 PP050126 to PP050250 PP050251 to PP050375 PP050376 to PP050500
VM-PMI	Default_Normal_PP_08 Default_Alert_PP_08 Default_EVAC_PP_08 Default_Pre_PP_08 MSG_005 to MSG_255	PP060001 PP060002 PP060003 PP060004 PP060005 to PP080255
ACHS 1	Channel_1_Relay_Confirmation Channel_2_Relay_Confirmation Channel_3_Relay_Confirmation Channel_4_Relay_Confirmation	PPCC0003 PPCC0004 PPCC0005 PPCC0006
ACHS 2	Channel_1_Relay_Confirmation Channel_2_Relay_Confirmation Channel_3_Relay_Confirmation Channel_4_Relay_Confirmation	PPCC0003 PPCC0004 PPCC0005 PPCC0006
ACHS	Channel_1_Relay_Confirmation Channel_2_Relay_Confirmation Channel_3_Relay_Confirmation Channel_4_Relay_Confirmation	PPCC0003 PPCC0004 PPCC0005 PPCC0006

## Operator layer device address

Figure 58 identifies the LEDs and switches on a D12LS-VM card. Table 78 lists the device addresses for the points on the VM-1 operator layer.

**Figure 58: D12LS-VM LED and switch numbering**

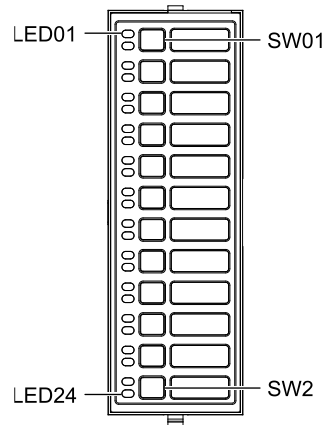

**Table 78: D12LS-VM LED operator layer device addresses**

Module type	Switch / LED	Address
1 <sup>st</sup> D12LS-VM	SW01 to SW12 LED01 to LED24	PP350001 to PP350012 PP351001 to PP351024
2 <sup>nd</sup> D12LS-VM	SW01 to SW12 LED01 to LED24	PP350101 to PP350112 PP351101 to PP351124
3 <sup>rd</sup> D12LS-VM	SW01 to SW12 LED01 to LED24	PP350201 to PP350212 PP351201 to PP351224

## Remote annunciator device addresses

Table 79 on page 197 lists the device addresses for points on RLED-C and K-RLED-C remote annunciators, RLED24 and K-RLED24 expanders, GCI and GCI-NB graphic annunciator cards, and GCIX expander cards. See also Figure 59, Figure 60, and Figure 61.

**Note:** Switch addresses do not apply to R-Series or K-R-Series remote annunciators and expanders. RLCD / K-RLCD and RLCD-C / K-RLCD-C remote annunciators do not have addressable points.

**Figure 59: RLED-C / K-RLED-C and RLED24 / K-RLED24 LED numbering**

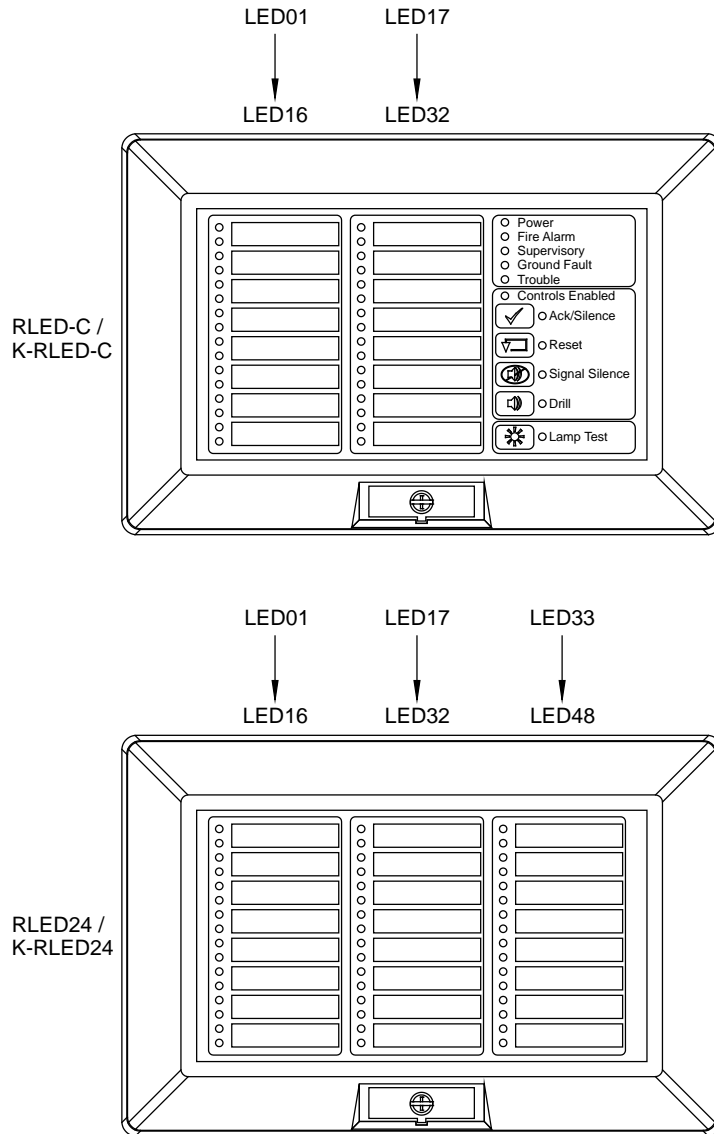

Figure 60: GCI and GCI-NB cards LED and switch numbering

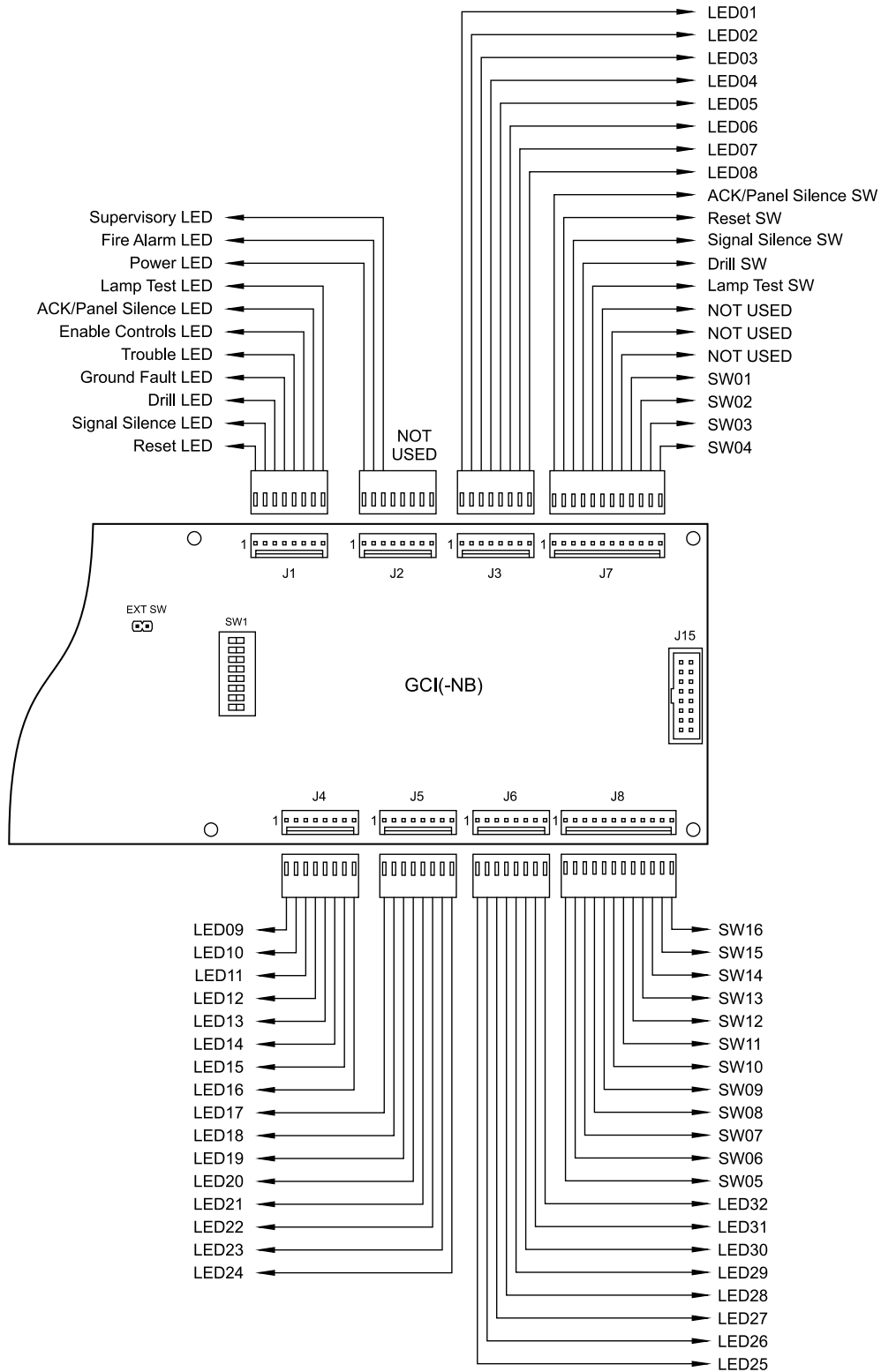
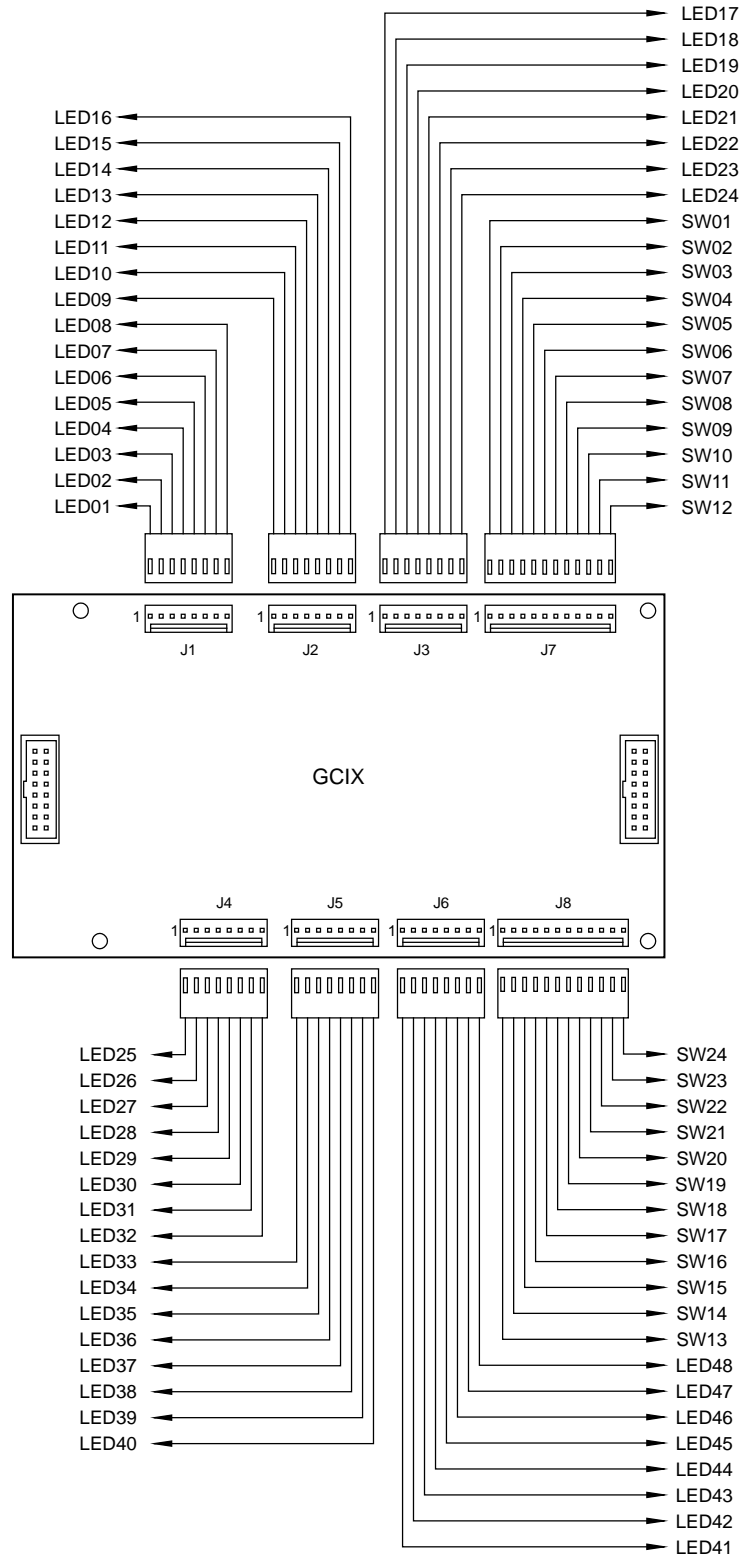

Figure 61: GCIX card LED and switch numbering



**Table 79: Remote annunciator device addresses**

No.	Type	LED or switch	Address
1	RLED-C / K-RLED-C or GCI(-NB)	LED01 to LED32 SW01 to SW16	PP040201 to PP040232 PP020249 to PP040264
	Expander 1	LED01 to LED48 SW01 to SW24	PP040301 to PP040348 PP040349 to PP040372
	Expander 2	LED01 to LED48 SW01 to SW24	PP040401 to PP040448 PP040449 to PP040472
2	RLED-C / K-RLED-C or GCI(-NB)	LED01 to LED32 SW01 to SW16	PP040501 to PP040532 PP020549 to PP040564
	Expander 1	LED01 to LED48 SW01 to SW24	PP040601 to PP040648 PP040649 to PP040672
	Expander 2	LED01 to LED48 SW01 to SW24	PP040701 to PP040748 PP040749 to PP040772
3	RLED-C / K-RLED-C or GCI(-NB)	LED01 to LED32 SW01 to SW16	PP040801 to PP040832 PP020849 to PP040864
	Expander 1	LED01 to LED48 SW01 to SW24	PP040901 to PP040948 PP040949 to PP040972
	Expander 2	LED01 to LED48 SW01 to SW24	PP041001 to PP041048 PP041049 to PP041072
4	RLED-C / K-RLED-C or GCI(-NB)	LED01 to LED32 SW01 to SW16	PP041101 to PP041132 PP021149 to PP041164
	Expander 1	LED01 to LED48 SW01 to SW24	PP041201 to PP041248 PP041249 to PP041272
	Expander 2	LED01 to LED48 SW01 to SW24	PP041301 to PP041348 PP041349 to PP041372
5	RLED-C / K-RLED-C or GCI(-NB)	LED01 to LED32 SW01 to SW16	PP041401 to PP041432 PP021449 to PP041464
	Expander 1	LED01 to LED48 SW01 to SW24	PP041501 to PP041548 PP041549 to PP041572
	Expander 2	LED01 to LED48 SW01 to SW24	PP041601 to PP041648 PP041649 to PP041672
6	RLED-C / K-RLED-C or GCI(-NB)	LED01 to LED32 SW01 to SW16	PP041701 to PP041732 PP021749 to PP041764
	Expander 1	LED01 to LED48 SW01 to SW24	PP041801 to PP041848 PP041849 to PP041872
	Expander 2	LED01 to LED48 SW01 to SW24	PP041901 to PP041948 PP041949 to PP041972

<b>No.</b>	<b>Type</b>	<b>LED or switch</b>	<b>Address</b>
7	RLED-C / K-RLED-C or GCI(-NB)	LED01 to LED32 SW01 to SW16	PP042001 to PP042032 PP022049 to PP042064
	Expander 1	LED01 to LED48 SW01 to SW24	PP042101 to PP042148 PP042149 to PP042172
	Expander 2	LED01 to LED48 SW01 to SW24	PP042201 v PP042248 PP042249 to PP042272
8	RLED-C / K-RLED-C or GCI(-NB)	LED01 to LED32 SW01 to SW16	PP042301 to PP042332 PP022349 to PP042364
	Expander 1	LED01 to LED48 SW01 to SW24	PP042401 to PP042448 PP042449 to PP042472
	Expander 2	LED01 to LED48 SW01 to SW24	PP042501 to PP042548 PP042549 to PP042572
9	RLED-C / K-RLED-C or GCI(-NB)	LED01 to LED32 SW01 to SW16	PP042601 to PP042632 PP022649 to PP042664
	Expander 1	LED01 to LED48 SW01 to SW24	PP042701 to PP042748 PP042749 to PP042772
	Expander 2	LED01 to LED48 SW01 to SW24	PP042801 to PP042848 PP042849 to PP042872
10	RLED-C / K-RLED-C or GCI(-NB)	LED01 to LED32 SW01 to SW16	PP042901 to PP042932 PP022949 to PP042964
	Expander 1	LED01 to LED48 SW01 to SW24	PP043001 to PP043048 PP043049 to PP043072
	Expander 2	LED01 to LED48 SW01 to SW24	PP043101 to PP043148 PP043149 to PP043172
11	RLED-C / K-RLED-C or GCI(-NB)	LED01 to LED32 SW01 to SW16	PP043201 to PP043232 PP043249 to PP043264
	Expander 1	LED01 to LED48 SW01 to SW24	PP043301 to PP043348 PP043349 to PP043372
	Expander 2	LED01 to LED48 SW01 to SW24	PP043401 to PP043448 PP043449 to PP043472
12	RLED-C / K-RLED-C or GCI(-NB)	LED01 to LED32 SW01 to SW16	PP043501 to PP043532 PP043549 to PP043564
	Expander 1	LED01 to LED48 SW01 to SW24	PP043601 to PP043648 PP043649 to PP043672
	Expander 2	LED01 to LED48 SW01 to SW24	PP043701 to PP043748 PP043749 to PP043772

No.	Type	LED or switch	Address
13	RLED-C / K-RLED-C or GCI(-NB)	LED01 to LED32 SW01 to SW16	PP043801 to PP043832 PP043849 to PP043864
	Expander 1	LED01 to LED48 SW01 to SW24	PP043901 to PP043948 PP043949 to PP043972
	Expander 2	LED01 to LED48 SW01 to SW24	PP044001 to PP044048 PP044049 to PP044072
14	RLED-C / K-RLED-C or GCI(-NB)	LED01 to LED32 SW01 to SW16	PP044101 to PP044132 PP044149 to PP044164
	Expander 1	LED01 to LED48 SW01 to SW24	PP044201 to PP044248 PP044249 to PP044272
	Expander 2	LED01 to LED48 SW01 to SW24	PP044301 to PP044348 PP044349 to PP044372
15	RLED-C / K-RLED-C or GCI(-NB)	LED01 to LED32 SW01 to SW16	PP044401 to PP044432 PP044449 to PP044464
	Expander 1	LED01 to LED48 SW01 to SW24	PP044501 to PP044548 PP044549 to PP044572
	Expander 2	LED01 to LED48 SW01 to SW24	PP044601 to PP044648 PP044649 to PP044672
16	RLED-C / K-RLED-C or GCI(-NB)	LED01 to LED32 SW01 to SW16	PP044701 to PP044732 PP044749 to PP044764
	Expander 1	LED01 to LED48 SW01 to SW24	PP044801 to PP044848 PP044849 to PP044872
	Expander 2	LED01 to LED48 SW01 to SW24	PP044901 to PP044948 PP044949 to PP044972
17	RLED-C / K-RLED-C or GCI(-NB)	LED01 to LED32 SW01 to SW16	PP045001 to PP045032 PP045049 to PP045064
	Expander 1	LED01 to LED48 SW01 to SW24	PP045101 to PP045148 PP045149 to PP045172
	Expander 2	LED01 to LED48 SW01 to SW24	PP045201 to PP045248 PP045249 to PP045272
18	RLED-C / K-RLED-C or GCI(-NB)	LED01 to LED32 SW01 to SW16	PP045301 to PP045332 PP045349 to PP045364
	Expander 1	LED01 to LED48 SW01 to SW24	PP045401 to PP045448 PP045449 to PP045472
	Expander 2	LED01 to LED48 SW01 to SW24	PP045501 to PP045548 PP045549 to PP045572

<b>No.</b>	<b>Type</b>	<b>LED or switch</b>	<b>Address</b>
19	RLED-C / K-RLED-C or GCI(-NB)	LED01 to LED32 SW01 to SW16	PP045601 to PP045632 PP045649 to PP045664
	Expander 1	LED01 to LED48 SW01 to SW24	PP045701 to PP045748 PP045749 to PP045772
	Expander 2	LED01 to LED48 SW01 to SW24	PP045801 to PP045848 PP045849 to PP045872
20	RLED-C / K-RLED-C or GCI(-NB)	LED01 to LED32 SW01 to SW16	PP045901 to PP045932 PP045949 to PP045964
	Expander 1	LED01 to LED48 SW01 to SW24	PP046001 to PP046048 PP046049 to PP046072
	Expander 2	LED01 to LED48 SW01 to SW24	PP046101 to PP046148 PP046149 to PP046172
21	RLED-C / K-RLED-C or GCI(-NB)	LED01 to LED32 SW01 to SW16	PP046201 to PP046232 PP046249 to PP046264
	Expander 1	LED01 to LED48 SW01 to SW24	PP046301 to PP046348 PP046349 to PP046372
	Expander 2	LED01 to LED48 SW01 to SW24	PP046401 to PP046448 PP046449 to PP046472
22	RLED-C / K-RLED-C or GCI(-NB)	LED01 to LED32 SW01 to SW16	PP046501 to PP046532 PP046549 to PP046564
	Expander 1	LED01 to LED48 SW01 to SW24	PP046601 to PP046648 PP046649 to PP046672
	Expander 2	LED01 to LED48 SW01 to SW24	PP046701 to PP046748 PP046749 to PP046772
23	RLED-C / K-RLED-C or GCI(-NB)	LED01 to LED32 SW01 to SW16	PP046801 to PP046832 PP046849 to PP046864
	Expander 1	LED01 to LED48 SW01 to SW24	PP046901 to PP046948 PP046949 to PP046972
	Expander 2	LED01 to LED48 SW01 to SW24	PP047001 to PP047048 PP047049 to PP047072
24	RLED-C / K-RLED-C or GCI(-NB)	LED01 to LED32 SW01 to SW16	PP047101 to PP047132 PP047149 to PP047164
	Expander 1	LED01 to LED48 SW01 to SW24	PP047201 to PP047248 PP047249 to PP047272
	Expander 2	LED01 to LED48 SW01 to SW24	PP047301 to PP047348 PP047349 to PP047372

No.	Type	LED or switch	Address
25	RLED-C / K-RLED-C or GCI(-NB)	LED01 to LED32 SW01 to SW16	PP047401 to PP047432 PP047449 to PP047464
	Expander 1	LED01 to LED48 SW01 to SW24	PP047501 to PP047548 PP047549 to PP047572
	Expander 2	LED01 to LED48 SW01 to SW24	PP047601 to PP047648 PP047649 to PP047672
26	RLED-C / K-RLED-C or GCI(-NB)	LED01 to LED32 SW01 to SW16	PP047701 to PP047732 PP047749 to PP047764
	Expander 1	LED01 to LED48 SW01 to SW24	PP047801 to PP047848 PP047849 to PP047872
	Expander 2	LED01 to LED48 SW01 to SW24	PP047901 to PP047948 PP047949 to PP047972
27	RLED-C / K-RLED-C or GCI(-NB)	LED01 to LED32 SW01 to SW16	PP048001 to PP048032 PP048049 to PP048064
	Expander 1	LED01 to LED48 SW01 to SW24	PP048101 to PP048148 PP048149 to PP048172
	Expander 2	LED01 to LED48 SW01 to SW24	PP048201 to PP048248 PP048249 to PP048272
28	RLED-C / K-RLED-C or GCI(-NB)	LED01 to LED32 SW01 to SW16	PP048301 to PP048332 PP048349 to PP048364
	Expander 1	LED01 to LED48 SW01 to SW24	PP048401 to PP048448 PP048449 to PP048472
	Expander 2	LED01 to LED48 SW01 to SW24	PP048501 to PP048548 PP048549 to PP048572
29	RLED-C / K-RLED-C or GCI(-NB)	LED01 to LED32 SW01 to SW16	PP048601 to PP048632 PP048649 to PP048664
	Expander 1	LED01 to LED48 SW01 to SW24	PP048701 to PP048748 PP048749 to PP048772
	Expander 2	LED01 to LED48 SW01 to SW24	PP048801 to PP048848 PP048849 to PP048872
30	RLED-C / K-RLED-C or GCI(-NB)	LED01 to LED32 SW01 to SW16	PP048901 to PP048932 PP048949 to PP048964
	Expander 1	LED01 to LED48 SW01 to SW24	PP049001 to PP049048 PP049049 to PP049072
	Expander 2	LED01 to LED48 SW01 to SW24	PP049101 to PP049148 PP049149 to PP049172

## Logic group addresses

Table 80 lists the addresses for VM-1 logic groups.

**Table 80: VM-1 logic group addresses**

<b>Logical output</b>	<b>Address</b>
Command lists	00220001 to 00221999
Instruction text	00240001 to 00240999
Zone groups	00250001 to 00250999
Service groups	00260001 to 00260255
And groups	00270001 to 00270999

# Appendix C

# Programming options

## **Summary**

This appendix summarizes panel programming options.

## **Content**

Programming options 204

# Programming options

For programming instructions, refer to the VM-CU Help.

## NOTICE TO USERS, INSTALLERS, AUTHORITIES HAVING JURISDICTION, AND OTHER INVOLVED PARTIES:

This product incorporates field-programmable software. In order for the product to comply with the requirements in the *Standard for Control Units and Accessories for Fire Alarm Systems*, UL 864, certain programming features or options must be limited to specific values or not used at all as indicated below.

Programmable feature or option	Permitted in UL 864? (Y/N)	Possible settings	Settings permitted in UL 864
Telephone line supervision	Y	No Yes	Yes
Second telephone line	Y	No Yes	No [1] Yes [11]
Event Resound	Y	00:00:00 to 99:59:59	00:00:00 [2] to 24:00:00
AC Power Delay	Y	Disabled 01:00 to 45:00	01:00 to 03:00
Event message routing	Y	All Cabinets No Cabinets User defined routes (1 to 15)	All Cabinets No Cabinets [3] User defined routes (1 to 15) [4]
Event message display filtering: Alarm, Supervisory, and Trouble options	Y	Enabled Disabled	Enabled Disabled [5]
Delays (programmed in correlations)	Y	0 to 65,535 seconds	0 to 65,535 seconds [6]
Alarm verification	Y	0 to 56 seconds	0 to 44 seconds
Automatic alarm signal silence	Y	0 to 60 minutes	3 to 30 minutes
Silence inhibit	Y	0 to 3 minutes	3 minutes
CMS event reporting priority (programmed in correlations)	Y	1 to 255	1 to 255 [7]
CMS activate and restore messages (programmed in correlations)	Y	Send on activation Send on restoration	Activation and restoration triggers must match the message type
Zone group member device types	Y	GENALARM SMOKE SMOKEVFY HEAT PULL STAGEONE STAGETWO WATERFLOW COALARM COSUPERVISORY	GENALARM SMOKE SMOKEVFY [8] HEAT PULL STAGEONE [8] STAGETWO [8] WATERFLOW COALARM COSUPERVISORY

Programmable feature or option	Permitted in UL 864? (Y/N)	Possible settings	Settings permitted in UL 864
AND group member device types, Activation event: Q1 - Alarm	Y	GENALARM SMOKE SMOKEVFY HEAT PULL STAGEONE STAGETWO WATERFLOW COALARM COSUPERVISORY	GENALARM SMOKE SMOKEVFY [9] HEAT PULL STAGEONE [9] STAGETWO [9] WATERFLOW COALARM COSUPERVISORY
AND group device activation count	Y	1 to 255	1 to 255 [10]
Input modules: Personality code 18	N	N/A	N/A
GSA-IO(-MIO) modules: Personality codes 35 and 36	N	N/A	N/A
CO Supervisory	N	Latching Nonlatching	N/A
CO Monitor	N	Latching Nonlatching	N/A
Bypass command	N	N/A	N/A

- [1] Allowed only when the supervising station supervises the telephone line and annunciates fault conditions within 200 seconds
- [2] Allowed only on control panels that transmit trouble event signals off premises
- [3] Allowed only with monitor device types and switches
- [4] Allowed only if the user route includes the control panel
- [5] Allowed only on nonrequired remote annunciators
- [6] Allowed only when setting does not prevent the activation or transmission of alarm or supervisory signals within 10 seconds or trouble signals within 200 seconds
- [7] When priorities are used, alarm events must have a higher priority than supervisory and trouble events
- [8] Not allowed in Zone groups that are used to initiate the release of extinguishing agent or water
- [9] Not allowed in AND groups that are used to initiate the release of extinguishing agent or water
- [10] A minimum device activation count of 2 is required if the AND group or matrix group is used to initiate the release of extinguishing agents or water
- [11] If only one type of passive communication is available at the protected premises, there shall be two channels provided. Separate paths throughout the protected premises and through any common carrier or third party communications network to the fire signal receiving center shall be provided for each communication channel.



# Glossary

Term	Definition
active	Points that are in an alarm state.
activate	To turn on or energize. Pertains to outputs (including logical outputs).
alarm	The state of a fire alarm initiating device that has detected a smoke or fire condition. The state of a security device that has been triggered.
alarm silence timer	A panel option that automatically silences the notification appliance circuits (NACs) after a preprogrammed time limit after the last alarm.
AND statement	A system input defined in the VM-CU that activates when <i>all</i> the input conditions as indicated in its AND statement list, are active.
card	Modules that connect to the electronics chassis and control-indicating modules.
Class A IDC	A circuit connected directly to initiating devices that signals a trouble condition upon an open condition on the circuit. All devices wired on the circuit to continue to operate in the event of a single open. Similar to Style D & E integrity monitoring.
Class A NAC	A circuit, connected directly to notification appliances that signals a trouble condition upon an open or shorted condition on the circuit. All appliances wired on the circuit to continue to operate in the event of a single open. Similar to Style Z integrity monitoring.
Class B IDC	A circuit, connected directly to initiating devices that signals a trouble condition upon an open condition on the circuit. All devices wired on the circuit to continue to operate up to the location of a break. Similar to Styles A, B, C, & D integrity monitoring.
Class B NAC	A circuit connected directly to notification appliances that signals a trouble condition upon an open or shorted condition on the circuit. All appliances wired on the circuit to continue to operate up to the location of a break. Similar to Styles W, X, and Y integrity monitoring.
CMS	Central monitoring station
command list	A predefined list of VM-CU commands. You can activate a command list from a correlation, from another command list, or from an external command and control system.
DACT	Digital alarm communicator transmitter. A system component that transmits digital alarm, supervisory, and trouble signals to a central monitoring station (CMS) over dial-up telephone lines. The VM-DACT is a DACT.

database	User-defined, permanently stored, system parameters containing system zone definitions, device types, responses, messages, etc.
device	Circuits, buttons, or LEDs that exist on the electronics chassis and all addressable devices connected by field wiring.  Any detector or module.
device address	A number that uniquely identifies a detector or module on a signaling line circuit
dialer	See DACT.
disable	Prevent an input, output, or system feature from functioning.
download	To send a project database configured in the VM-CU on your PC to the system control panel.
ECP	External Command Protocol. This protocol is used for point-to-point communication between an FACP and external equipment such as a computer running FireWorks.
enable	Permit an input, output, or system feature to function.
EVAC	Emergency Voice/Alarm Communications.
fiber optic	Communication format that uses light signals carried on glass fibers to transmit and receive data.
global domain	Features that operate in all network cabinets.
group	A collection of VM devices defined in the VM-CU that is treated as a single entity for programming purposes. Groups can have messages and responses over and above the messages and responses of the individual group members.
IDC	Initiating device circuit. An input circuit connected directly to any manual or automatic initiating device, whose normal operation results in an alarm or supervisory signal indication at the control panel. The electrical integrity of the circuit is monitored by the fire alarm system.
label	A unique identifier for an object.
local system	A system that operates according to the provisions of NFPA 72.
loop	The wiring that connects devices to the fire alarm control panel.
modem	Short for modulator/demodulator. A communications device that enables a computer to transmit information over a standard telephone line. Sophisticated modems are also capable of such functions as automatic dialing, answering, and redialing in addition to transmitting and receiving. The VM-DACT includes a modem.
NAC	Notification appliance circuit. A circuit connected directly to notification appliances. The electrical integrity of the circuit is monitored by the fire alarm system.
output	A signal generated by the system based upon responses defined in the system database and sent to external field devices. Outputs are LEDs and modules.
output priority	A system of hierarchy that allows or prevents setting or resetting outputs. Output priorities range from low to high.

personality code	A number code used to set the configuration and operation of a GSA module. The personality code is either factory installed or must be downloaded into GSA modules for proper operation.
POTS	Plain Old Telephone Service. Standard telephone service employing analog signal transmission over copper loops.
power-limited	Wiring and equipment that conforms with and is installed to the <i>National Electrical Code</i> , Article 760, power-limited provisions.
proprietary system	A system that operates according to the provisions of NFPA 72.
pseudo point	An input or output point that is not a physical device. For example, ground fault and communication fault notifications.
reset	An active condition or command used to force an output to its OFF condition. An output's OFF state may be in the restored condition (normal condition, not under the influence of a response) or the reset condition. An output reset state contains a priority level.
response	A list of outputs or functions that occur because of an input change of state.
restore	Refers to a condition of an input, where the input is not active. It also refers to the condition of an output where the output is not in its set or reset condition and does not have a priority value associated with it.
riser	An electrical path that contains power or a signal that is used by multiple outputs, zones, or circuits.
RS-232	A serial communications format normally used for serial peripheral devices from a computer. RS-232 cables have a maximum length of 50 ft (15.2M).
RS-485	A serial differential communications format used to communicate between the panel and remote annunciators.
SMTP	Simple Mail Transfer Protocol. The Internet standard for email transmission.
VM-CU	VM-1 Configuration Utility. Software that lets programmers configure and program a VM-1 control panel.
sensitivity	The relative percent obscuration of a detector.
sequence	A series of actions separated by time delays.
service group	A collection of devices defined in the VM-CU that are configured for testing as a group using the system test function.
signaling line circuit	The wiring that connects devices to the fire alarm control panel.
supervisory circuit	An IDC input circuit used to monitor the status of critical fire protection equipment.
supervisory open (trouble)	A condition generated when a supervisory zone is open or in ground fault, or when a device is not responding to a poll.
System definition utility	See VM-CU.
time control	An input activated by the time of day or day of the month.
verification alarm	Upon receipt of an alarm by a smoke detector, verified detectors attempt to automatically reset. Receipt of a second alarm within the 60-second confirmation period after the automatic detector reset period is indicative of a verified alarm.

---

zone	A group of detectors and modules defined in the VM-CU that has a unique zone number and acts as a single entity for programming purposes whenever any component of the zone is activated
------	--

---

# Index

## 3

3-TAMP, 11

## A

abnormal points, 40

access levels, 18

accessing menus, 35

accessories, 11

ACHS, 10

ACK/Panel Silence button, 37

ACK/Panel Silence button and LED, 13

acknowledging events, 37

Activate Menu, 22

addresses

card, 42

entering, 36

IP, 42

system, 190

Advisory messages, iii

alarm

clearing history, 38

count, 42

history, 16, 41

indications, 31

outputs, 31

sensitivity threshold, 49

state, 31

Alarm LED, 14

Alarm queue, 17

Alarm report, 40

Alarm Silence button and LED, 13

Alert

special page mode, 63

All Active Points report, 40

All Call, 67

special page mode, 63

All Call button and LED, 61, 62

All Call Minus, 67

special page mode, 63

All Call Minus button and LED, 61, 62

alphanumeric

display, 13

alphanumeric (continued)

keypad, 14

alternate alarm sensitivity, 49

alternate message routing, 50

Alternate Sensitivity, 49

AND group

disable, 45

enable, 45

announcements. *See* Paging

annunciator

local, 10

remote, 11

audio amplifier

changing the output state, 48

wiring, 84

audio controller

EAEC, 62

audio database, 42

audio riser, 62

audio synchronization, 76

## B

backbox, 8

Backspace button, 14

banner, 16

batteries, 86

calculating minimum ampere-hour capacity, 183

booster power supplies, 86

bootstrap, 42

buzzer, 15

silencing an alarm, 37

silencing the panel, 36

Buzzer Silence button, 62

## C

CAB6B, 8

installing, 79

cable properties, 168

calculating

maximum length of network, 169

maximum NAC circuit cable length, 177

maximum wire capacitance per foot, 169

- calculating (continued)
  - minimum battery ampere-hour capability, 183
- capabilities, 5, 7
- card
  - address, 42
  - bootstrap version, 42
  - database version and date, 42
  - disable, 44
  - enable, 45
  - firmware version, 42
  - type installed, 42
- CDR-3, 12
  - baud rate, 99
  - parity, 99
  - wiring for coded tone output, 99
  - wiring for printer, 99
- chain errors, 159
- changing
  - access level password, 50
  - alarm sensitivity threshold, 49
  - event message routes, 50
  - output state, 47
  - screen language, 51
- channel selector card, 10
- channels, 63
- CLA-PS10, 9
- Class A adapter card, 9
- clearing the alarm history, 38
- CO sensor module, 110
- coder, 12
- command
  - menus, 20
  - selecting, 35
- configuration utility. *See* VM-CU
- control panel architecture, 5
- control-indicating module, 83
  - buttons, 56
  - D12LS-VM, 10
  - disabling button, 57
  - disabling LED, 57
  - disabling module, 56
  - enabling button, 57
  - enabling LED, 57
  - enabling module, 56
  - troubleshooting, 130
  - type installed, 42
- CPU fail LED, 15
- CPU firmware version, 42
- cursor keypad, 14
- D**
- D12LS-VM. *See* control-indicating module
- DACT compliance report, 43
- data network specifications, 168
- database
  - audio, 42
  - card, 42
  - date, 42
  - download, 51
  - serial number, 42
  - VM-CU, 42
- date, 55
  - LCD screen, 16
- details
  - event messages, 39
- Details button, 14
- detector
  - cleaning, 111
  - maintenance, 109
  - replacing a V-Series optical chamber, 110
  - replacing components, 113
- detector trouble messages, 161
- device
  - disable, 44
  - enable, 44
  - hardware layer, 82
  - maintenance reports, 41
  - message, 17
  - operator layer, 82
  - trouble, 160
- diagnostic tools, 157
- dirty detectors, 41
- disable
  - indications, 32
  - output, 32
  - state, 31
- Disable LED, 15
- Disable Menu, 21
- Disabled Points report, 40
- disabling
  - AND group, 45
  - cards, 44
  - control-indicating module, 56
  - control-indicating module button, 57
  - control-indicating module LED, 57
  - devices, 44
  - Instruction Text group, 45
  - Service group, 45
  - Zone group, 45
- door. *See* VMD(G/R)
- download
  - database, 51
  - errors, 105
  - using Ethernet, 52
  - using RS-232, 53
  - using TCP/IP, 52
- drill
  - output, 34
  - state, 34

Drill button  
 remote annunciator, 69  
 Drill button and LED, 14  
 dual line dialer card. See VM-DACT

## E

EAEC, 62  
 ECP, 72  
 electronics chassis. See VM-ELEC  
 email, 72  
 addresses, 72  
 Enable Menu, 21  
 enabling  
 AND group, 45  
 cards, 45  
 control-indicating button, 57  
 control-indicating LED, 57  
 control-indicating module, 56  
 devices, 44  
 Instruction Text group, 45  
 Service group, 45  
 Zone group, 45  
 Enter button, 14  
 Ethernet  
 download, 52  
 wiring, 72  
 Ethernet card. See VM-ETH  
 event message  
 active points, 17  
 details, 39  
 most recent, 17  
 number, 17  
 queue, 17  
 routes, 50  
 screen, 16  
 selecting, 36  
 type, 17  
 exiting menus, 36

## F

fiber optics cable worksheet, 187  
 fiber optics module, 10, 89  
 troubleshooting, 129  
 firefighter telephone, 62  
 answering calls, 67  
 firefighter telephone kit. See VM-MFK  
 FireWorks  
 IP dialer, 72  
 RJ-45, 72  
 firmware version  
 card, 42  
 CPU, 42

## G

ground faults  
 signaling line circuit, 150  
 groups, 45  
 GSA-REL, 11

## H

hardware layer devices, 82  
 history  
 clearing alarms, 38  
 holiday lists  
 adding, 55  
 deleting, 55  
 editing, 55  
 HyperTerminal, 164

## I

indications  
 alarm state, 31  
 disable state, 32  
 monitor state, 33  
 supervisory state, 32  
 test state, 34  
 trouble state, 33  
 installing components, 79  
 Instruction Text  
 disabling group, 45  
 enabling group, 45  
 IP  
 accounts, 72  
 configuring services, 73  
 services, 72  
 IP addresses, 42  
 IP dialer, 72

## K

K-R-Series remote annunciators, 11, 67  
 compatible models, 68  
 DIP switch settings, 104  
 LCD model, 69  
 LED model, 71

## L

lamp test, 46  
 LCD  
 screen, 13  
 screen language, 51  
 limitations, 2  
 lock  
 remote read, 54  
 remote write, 51  
 logic groups, 45  
 loop controller, 155

loop controller card, 9  
 loop controller circuit  
   ground faults, 150

## M

Main Menu, 20  
   accessing, 35  
 maintenance  
   log, 113  
   required tools, 109  
   schedule and tests, 113  
   tests, 109  
   visual inspections, 108  
 maintenance reports, 41  
 mapping error, 155, 156, 158  
   message, 158  
 marketplace setting, 42  
 message counters, 160  
 microphone, 60, 61  
   local, 67  
   remote, 11  
 MIR-PRT/S, 12  
   installing, 95  
 modules  
   maintenance, 110  
   removing or replacing, 124  
   trouble messages, 163  
 monitor  
   indications, 33  
   output, 33  
   state, 33  
 Monitor LED, 14  
 Monitor queue, 17  
 Monitor report, 40

## N

NAC adapter card, 9  
 NAC AUX circuits, 80  
 NAC circuit cable length, 177  
 NAC synchronization, 76  
 network card, 9  
 network data riser  
   cable properties, 168  
   length, 169  
   limits, 168  
   specifications, 168  
   wire capacitance, 169  
 normal state, 31  
 notification appliance circuit  
   determining total cable length, 177

## O

obscuration, 49  
 off-normal, 16

operating states, 31  
 operator controls  
   paging interface, 60, 61  
 operator layer devices, 82  
 option cards, 9  
   installing, 82  
 output  
   alarm state, 31  
   changing states, 47  
   disable state, 32  
   monitor state, 33  
   supervisory state, 32  
   test state, 33  
   trouble state, 32  
 Output report, 40  
 overview, 4

## P

Page By Phone button and LED, 62  
 Page To Alert, 67  
 Page To Alert button and LED, 61, 62  
 Page To Evac, 67  
 Page To Evac button and LED, 61, 62  
 paging, 10  
   local microphone, 67  
   operator controls, 60, 61  
   troubleshooting, 133  
 Paging Volume LED, 60, 62  
 Power LED, 14  
 power up, 34  
 primary alarm sensitivity, 49  
 Primary Msg Route, 50  
 printer, 12  
   backup power supply, 98  
   installing, 95  
 printing  
   abnormal points list, 40  
   active points list, 40  
   DACT Compliance report, 43  
   maintenance reports, 41  
   revision report, 42  
 Program Menu, 26  
 programmable features, 8  
 programming options, 204  
 PS10-4B, 8  
   installing, 80  
   NAC AUX circuits, 80  
   troubleshooting, 125  
 pseudo point descriptions, 134  
 Push-to-talk (PTT), 60, 61, 67

## Q

queues, 17

**R**

Ready To Page LED, 60, 62  
 relays  
   changing output state, 48  
 remote annunciator, 11  
 Remote Read Lock, 54  
 Remote Write Unlock, 51  
 Reports Menu, 25  
 Reset button and LED, 14  
 resetting the system, 38  
 restarting the system, 38  
 Restore Menu, 24  
 revision report, 42  
 RS-232 download, 53  
 RS-485 option card, 9  
 R-Series remote annunciators, 11, 67  
   compatible models, 68  
   DIP switch settings, 104  
   LCD model, 69  
   LED model, 71  
 runtime errors, 105

**S**

selecting  
   alternate alarm sensitivity, 49  
   alternate message routing, 50  
   event message, 36  
   primary alarm sensitivity, 50  
   primary message routing, 50  
   queues, 36  
 Selective special page mode, 63  
 semiflush mount, 12  
 Service Detector LED, 14  
 Service group  
   disable, 45  
   enable, 45  
 setting  
   date, 55  
   time, 54  
 SIGA-AA30/50, 11  
 signal priority, 63  
 signaling line circuit  
   operation, 146  
   real-time status, 163  
   troubleshooting, 147  
 silencing  
   alarm signals, 37  
   panel buzzer, 36  
 smartphone, 72  
 spares parts list, 124  
 standby batteries, 86  
 static-sensitive handling, 124  
 status  
   indicators, 14

status (continued)  
   reports, 40  
 Status Menu, 20  
 strobe synchronization, 76  
 substituting  
   devices, 151  
   loop controller, 155  
 supervisory  
   indications, 32  
   output, 32  
   state, 32  
 Supervisory LED, 15  
 Supervisory queue, 17  
 Supervisory report, 40  
 synchronization, 76  
 system  
   addresses, 190  
   capabilities, 5, 7  
   enabling time controls, 46  
   normal screen, 15  
   off-normal screen, 16  
   overview, 4  
   requirements, 12  
   resetting, 38  
   restarting, 38  
   revision report, 42  
   setting the date, 55  
   setting the time, 54

**T**

TCP/IP communications, 54  
 telephone, 62  
   answering calls, 67  
 test  
   indications, 34  
   state, 33  
 Test LED, 14  
 Test Menu, 27  
 Test report, 40  
 testing  
   alarm input devices, 47  
   lamp, 46  
   LCD and LEDs, 46  
   preliminary field wiring, 89  
   V-Series devices, 46  
 texting, 72  
 time  
   LCD screen, 16  
   setting, 54  
 time controls, 46  
 time-out, 18, 50  
 TRIM6, 12  
 trouble  
   indications, 33  
   output, 32

trouble (continued)  
 state, 32  
 trouble and maintenance log, 121  
 Trouble LED, 15  
 Trouble queue, 17  
 trouble registers, 160  
 Trouble report, 40  
 Trouble Tables, 163  
 troubleshooting, 124

**U**

UL 864, 76  
 unlock  
 remote read, 54  
 remote write, 51  
 user access levels, 18  
 user interface, 12

**V**

viewing  
 abnormal points, 40  
 active points list, 40  
 alarm history, 41  
 DACT compliance report, 43  
 maintenance reports, 41  
 revision report, 42  
 status reports, 40  
 VM-1 models, 5  
 VM-CPU, 9, 82  
 troubleshooting, 126  
 VM-CU, 8  
 database version, 42  
 version, 42  
 VMD(G/R), 9  
 VM-DACT, 10  
 configuring, 90  
 overview, 90  
 troubleshooting, 131  
 VM-ELEC, 7, 9  
 installing, 81  
 VM-ETH, 10  
 VM-ETH1, 10  
 VM-ETH2, 10  
 VM-ETH3, 10  
 VM-LCD, 9, 83  
 VM-MFK, 10  
 installing, 83  
 VM-NOC, 9  
 VM-NOCF, 10  
 VM-PMI, 10  
 channels, 63  
 installing, 83  
 special page modes, 63  
 troubleshooting, 133

VM-SLC, 9  
 VM-SLC-HC, 9  
 VM-SLCXB, 155  
 V-Series devices  
 diagnostic tools, 157  
 V-Series loop  
 branch length, 170  
 determining total length, 176  
 wire length, 170

**W**

wire length calculations  
 NAC circuit, 177  
 network data riser, 168, 169  
 V-Series loops, 170

**Z**

zone  
 disabling group, 45  
 enabling group, 45