

2MP Fixed IR Bullet Analog Camera

UAC-B112-F28(40)-X-H



Overview

UAC-B112-F28(40)-X-H is a 2MP Fixed IR Bullet Analog Camera with a high-performance 1/3-inch CMOS sensor. It supports TVI/AHD/CVI/CVBS, which effectively enhances product adaptability and diversity of networking solutions. With SYV-75-3 or other coaxial cable types the camera can achieve low-cost, long-distance, anti-interference, and low delay mega-pixel video transmission. The camera supports IR cut filter and provides color images at daytime and black/white images at night.

Features

- 2MP high quality image
- TVI/AHD/CVI/CVBS
- IR-cut filter with auto switch (ICR)
- Supports 180° horizontal flip, 180° vertical flip
- OSD configuration menu, easy to operate
- IP67 waterproof and dustproof design, high reliability
- OSD configuration menu in 11 languages
- 3D noise reduction technology delivers clean and sharp images

Specifications

Model	UAC-B112-F28-X-H	UAC-B112-F40-X-H
Camera		
Max Resolution	2 MP	
Sensor Size	1/3.0" CMOS	
Min. Illumination	0.02 lux (F2.0, AGC ON) 0 lux (IR on)	
Lens		
Focus	2.8 mm	4.0 mm
Lens Mount	M12	
Angle of View (H)	90.5°	80.2°
Angle of View (V)	49.6°	40.7°
Angle of View (D)	109.5°	90.5°
Illuminator		
Illuminator Number	One IR illuminator	
Illumination Distance	20m	
Lifetime	≥ 60000 hours	
Video		

Resolution	1080P: 1920(H)×1080(V) 720P: 1280(H) ×720(V)
Frame Rate	TVI: 1080P@25fps (default), 1080P@30fps; 720P@25fps, 720P@30fps AHD: 1080P@25fps, 1080P@30fps; 720P@25fps, 720P@30fps CVI: 1080P@25fps, 1080P@30fps; 720P@25fps, 720P@30fps CVBS: PAL, NTSC
Shutter Time	PAL: 1/25 s-1/50000 s, NTSC: 1/30 s-1/50000 s
Image	
Exposure Mode	Four modes: Global (default), BLC, HLC, DWDR
Day/Night	Three modes: Auto (default), Day, Night
Digital Noise Reduction	2D/3D
White Balance	Two modes: Auto (default), Manual
WDR	DWDR
Smart IR	Support
Flip	Supports 180°horizontal flip, 180°vertical flip
Interface	
Power Interface	5.5 mm Power Interface
Video Output	BNC, supports TVI/AHD/CVI/CVBS
Operating Environment	
Temperature	-30 °C to 60 °C (-22 °F to 140 °F)

Humidity	≤ 95% RH (non-condensing)
Surge Protection	4 KV for power, 4 KV for video output interfaces
General	
Power	DC 12 V±25%
Power Consumption	MAX 2.0W
Mount	Corner Mount, Pole Mount
Dimensions	142mm*63mm*65mm (L*W*H)
Material	Plastic
Weight	145g(0.32lb)
OSD Menu Language	11 Languages: English, German, Spanish (Latin America), French, Italian, Japanese, Korean, Polish, Portuguese (Brazil), Russian, Turkish
Certification	
EMC	CE-EMC (EN 55032, EN 61000-3-3, EN IEC 61000-3-2, EN 55035), FCC (FCC 47 CFR part15 B)
Safety	CE-LVD (EN 62368-1)
Environment	CE-RoHS (2011/65/EU; (EU) 2015/863); WEEE (2012/19/EU)
Protection	IP67 (IEC 60529)

Dimensions

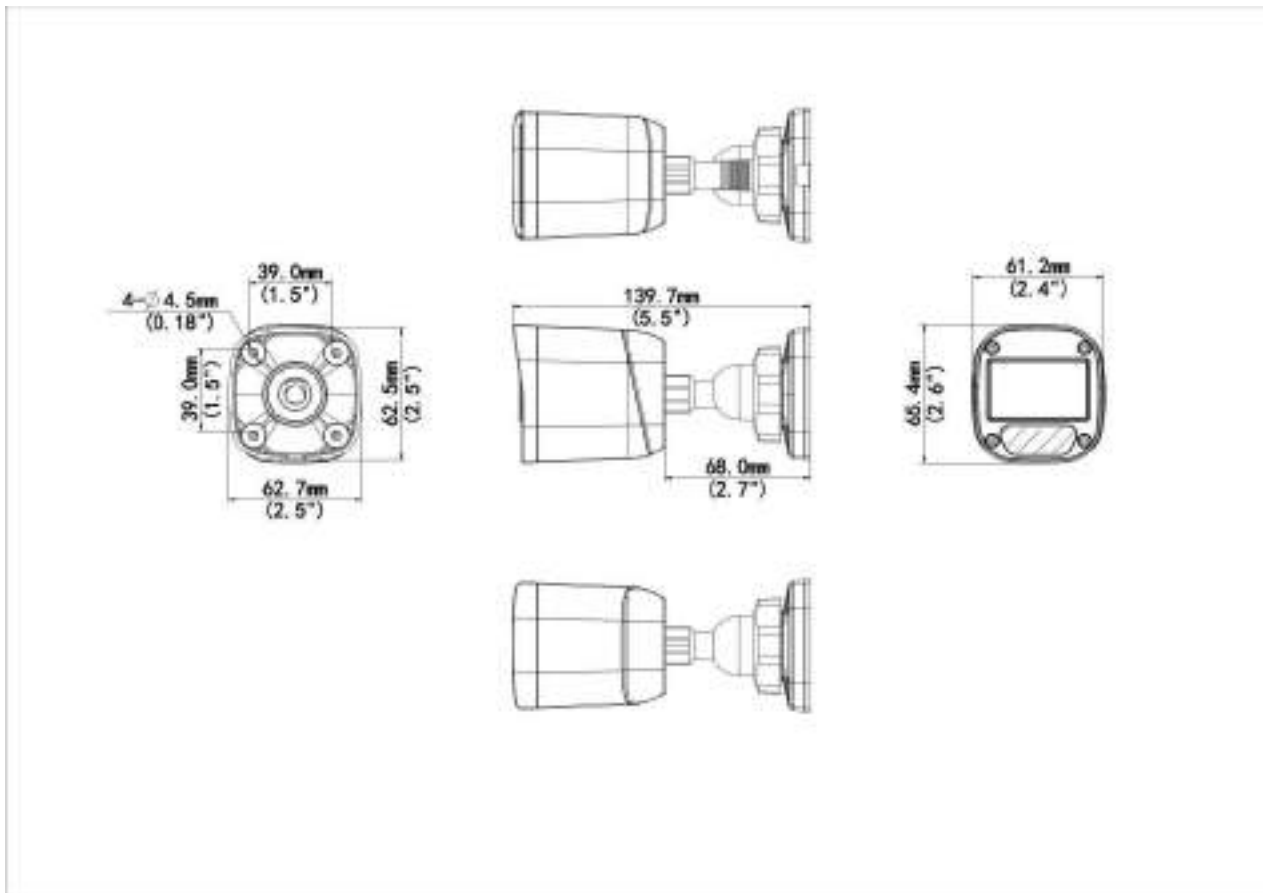

Accessories

TR-JB05-A-IN

Small Bullet Junction Box(Support wiring from behind,Square)



TR-A01-IN

NPT 3/4" Waterproof Cable Gland



PWR-DC1201B-UK

UNV DC12V/1A Wall Plug British Standard Power Adapter(Colorful Bag)



PWR-DC1201A-EU

DC12V/1A Wall Plug European Standard Power Adapter



TR-UP06-B-IN

Bullet Pole Mounting Bracket



TR-UC08-C

Bullet&Dome Corner Mounting Bracket



PWR-DC1201A-US

DC12V/1A Wall Plug American Standard Power Adapter



PWR-DC1201B-EU

UNV DC12V/1A Wall Plug European Standard Power Adapter(Colorful Bag)



TR-UP06-C-IN

Pole Mounting Bracket for Bullet Junction Box Only



PWR-DC1201A-UK

DC12V/1A Wall Plug British Standard Power Adapter



PWR-DC1201B-US

UNV DC12V/1A Wall Plug American Standard Power Adapter(Colorful Bag)



PWR-DC1201A-IND

UNV DC12V/1A Wall Plug Indian Standard Power Adapter-Colorful Bag



Zhejiang Uniview Technologies Co., Ltd.

No. 369, Xietong Road, Xixing Sub-district, Binjiang District, Hangzhou City, 310051, Zhejiang Province,

China Email: overseasbusiness@uniview.com; globalsupport@uniview.com <http://www.uniview.com>

©2025 Zhejiang Uniview Technologies Co., Ltd. All rights reserved.

*Product specifications and availability are subject to change without notice.

*Despite our best efforts, technical or typographical errors may exist in this document. Uniview cannot be held responsible for any such errors and reserves the right to change the contents of this document without prior notice.