

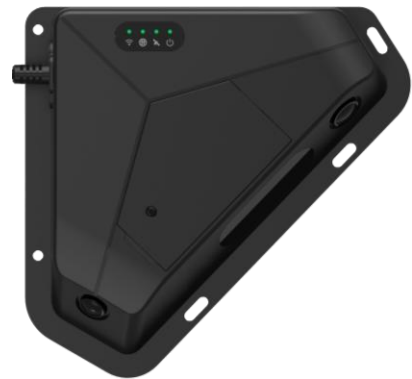

**Z5**

## Specification (Version 1.3)



## 1. Product Overview

Z5 is a highly integrated AI device designed for cargo management and video surveillance. It is equipped with a high-speed processor and a built-in operating system, combined with advanced H.265 compression and decompression technology and GPS positioning, supports 2Ch video recording with maximum resolutions of 4k and 1080p respectively, and is compatible with external Micro SD card. In addition, the Z5 features built-in Bluetooth function, which supports connecting external door sensor to obtain the open/close status of cargo door. It also supports 4G network connection and remote connection platform to transmit alarm information in time.

The device intelligently switches between different working modes based on its operational state. This enables the collection of fundamental cargo volume data while detecting and reporting abnormal alarms to the platform. At the same time, it optimizes power consumption to extend standby time when operating on battery power.

Z5 with a minimalist design tailored for cargo management. It is highly shock-resistant, exceptionally stable, and easy to use.

## 2. Product Features

- Supports cargo management algorithms
- Supports 1Ch 4K + 1Ch 1080P video
- Supports local recording with 1 external Micro SD card
- Supports H.265/H.264 compression technology
- Supports Wi-Fi
- Supports Bluetooth 5.0/5.1
- Supports 3G/4G connectivity with an external Nano SIM card
- Supports GPS
- Supports remote wake-up mode
- Supports low-power sleep mode
- Automatically switches between different working modes
- Supports various abnormal alarm detections
- Supports FT platform data visualization

### Cargo volume measurement function

Equipped with a built-in cargo volume measurement algorithm, it can detect the cargo loading rate in real-time and upload the data to the platform instantly.



### Cargo volume measurement

### Other functions



4G



GPS



Bluetooth



WiFi



Alarm

## 3. Product image



Z5



ABS box



Door sensor

## 4. Product Specifications

Product Model	
	Z5
Function overview	
	Volume measurement, 4G, Bluetooth, Wi-Fi, Preview, Recording, Playback, Upload, Positioning
System	
Operating system	Linux 4.19.125
Control mode	Veyes, Network (3G/4G/WIFI)
Video1	
Resolution	2160*3840@10fps
Lens	Focal length: 3.7mm, Aperture: F1.7
FOV	VFOV:67°, HFOV:125°
Exposure Time	1/30s-1/10000s
Minimum Illumination	0Lux(with white light turned on for low light conditions)
Video 2	

Resolution	1920*1080@25fps
Lens	Focal length: 2.19mm, Aperture: F2.45
FOV	VFOV:152°, HFOV:83°
Exposure Time	1/30s-1/10000s
Minimum Illumination	0Lux(with white light turned on for low light conditions)
Audio	
	None
Recording	
Video Compression Format	H.264/H.265
Image Quality	Adjustable from Level 1 to Level 8 (Level 1 is the best)
Recording Mode	Power-on/Manual/Timed/Alarm Event Recording
Alarm pre-recording	0-60min
Alarm Post-recording	0-30min
Playback	
Playback Channel	Supports local single-channel playback
Preview mode	Time, Channel, Event
Network	
WIFI	Supports 2.4G 802.11 b/g/n/ax 5G 802.11 a/n/ac/ax
3G/4G	<b>Supported Version</b> <b>North America Version</b> LTE FDD: B2/B4/B5/B12/B13/B14/B66/B71 WCDMA: B2/B4/B5 <b>Europe &amp; Asia Version</b> LTE FDD: B1/B3/B7/B8/B20/B28A WCDMA: B1/B8 GSM: B3/B8 <b>Latin America Version</b> LTE FDD: B1/ B2/B3/B4/B5/B7/B8/B28 LTE TDD: B40 WCDMA: B1/B2/B5/B8 GSM: B2/B3/B5/B8 <b>China Mainland Version</b> LTE-FDD: B1/B3/B5/B8 LTE-TDD: B34/B38/B39/B40/B41 WCDMA: B1/B5/B8

	 <p>Warning: It is required to use an industrial-grade Nano SIM card (MP2). The use of standard-grade Nano SIM cards (MP1) is prohibited. The company will not be held responsible for any issues arising from the use of standard-grade Nano SIM cards.</p>
<b>Positioning</b>	
GPS	Positioning, Speed Detection, Time Synchronization
<b>Sensor</b>	
<b>Gravity Sensor</b>	Built-in six-axis inertial sensor
<b>Storage</b>	
Micro SD	1 x Micro SD Card, Max Support 512G
<b>Interface</b>	
USB	Mini USB port
RS232	1Ch
Number of I/O	2Ch Input, 2Ch Output
<b>Power</b>	
Input	DC 10-36V
Vehicle electric charging power	Max 16W
Solar Panel Power	Max 7W
Battery capacity	10.2Ah/73.44Wh, Built-in
Maximum Typical Power Consumption	5.5W
Sleep Power Consumption	≈0.2W
<b>Physical Characteristics</b>	
Z5 Dimensions	198mmx191mmx42mm
ABS Battery Dimensions	244mmx236mmx27mm
Door Sensor Dimensions	Door sensor detector: 106mmx53mmx29mm Door sensor Magnet: 80mmx28mmx20mm
Z5 Weight (Include bracket)	1.19Kg
ABS Box Weight	2.12Kg

(Include bracket)	
Door Sensor Weight	0.13Kg
Packaging Information (Kits, include Z5 Host、ABS Box、Door sensor)	
Product Volume	L455*W390*H160mm
Single Unit Weight	4.34Kg
Master Carton Volume	L475*W338*H410mm
Units Per Carton	2Pcs
Carton Weight	9.56Kg
Operating Environment	
Operating Temperature	-40°C~+70°C
Storage Temperature	-40°C~+85°C
Operating Humidity	8%-95% (non-condensing)
Storage Humidity	8%-95% (non-condensing)

## 4.Product Dimension Drawing (mm)

### 4.1. Z5 Dimension Drawing (with Bracket)

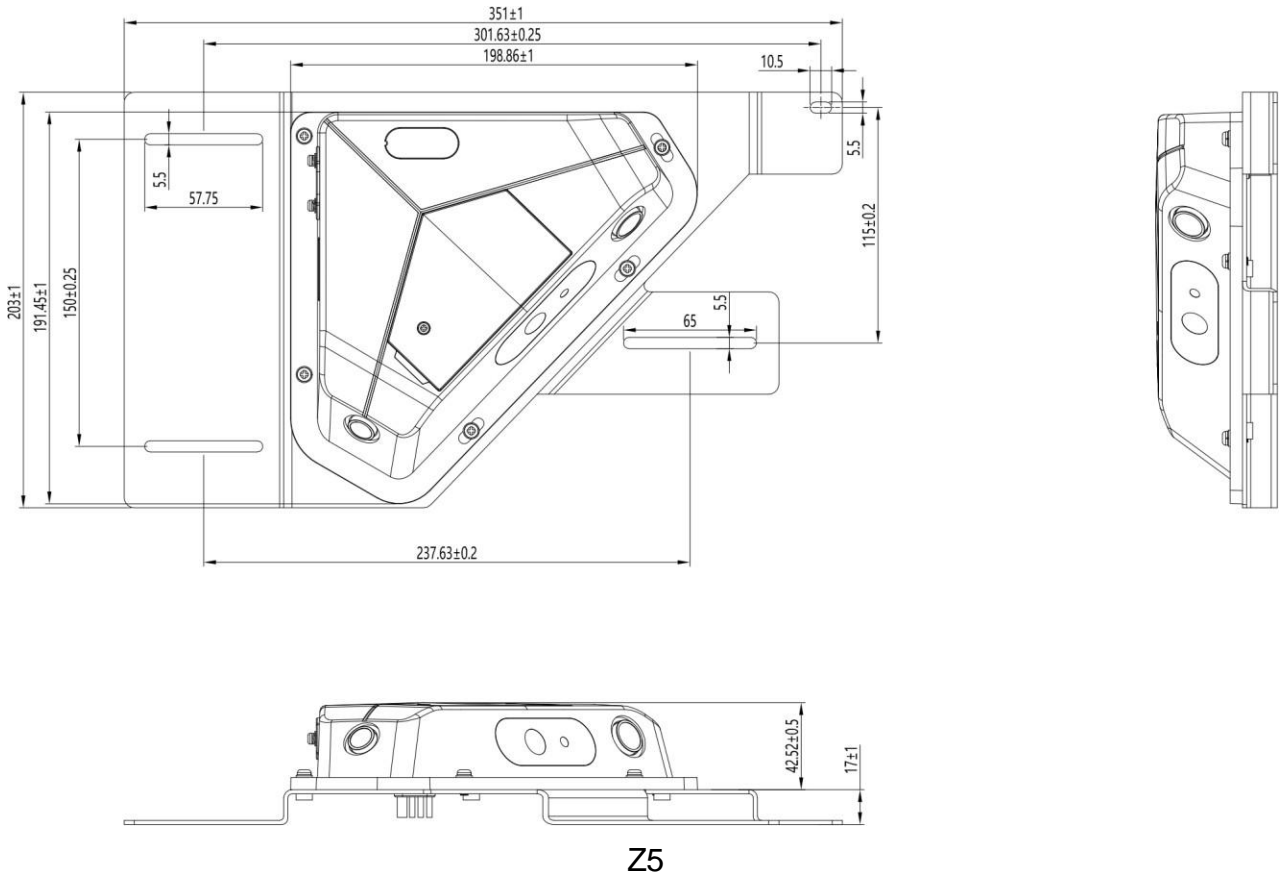

**4.2 ABS Battery Dimension Drawing ( with Bracket )**

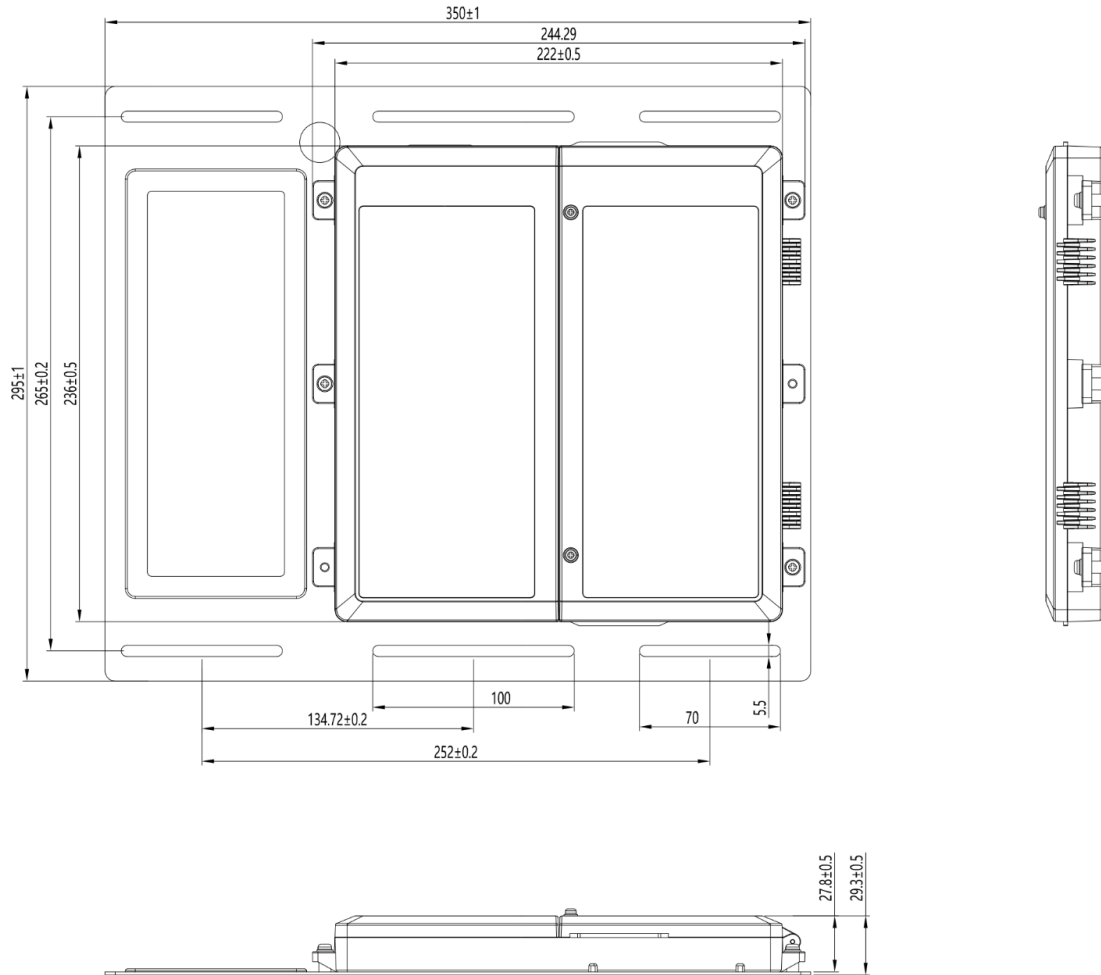

**ABS BOX**

**4.3 Door Sensor Dimension Drawing**

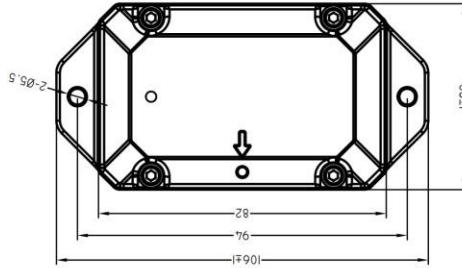
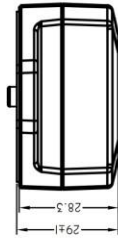
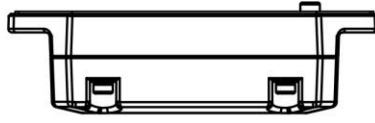

Door sensor detector

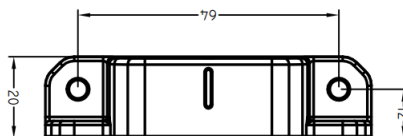
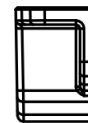
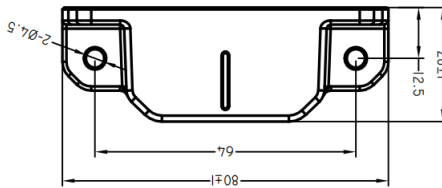
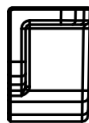

Door sensor magnet

## 5. Device Interface

### 5.1. Interface Table

Serial No.	Interface	Function/Screen printing/Interface	Description
1	Power Switch	ON/OFF	Power switch for the device
2	SIM Card Slot	SIM	SIM card slot
3	TF Card Slot	TF	TF card slot(Micro SD)
4	Indicator Light	Indicator Light	Power, GPS, Network, Wi-Fi status indicator lights
5	Micro USB	Micro USB	Micro USB interface
6	Host Tail Line	Power Input	1. DC10-36V power input, PON power supply; 2. Interface: DC IN+, DC IN-, ACC
7		Number of I/O	2 inputs, 1 outputs
8		Serial Port	RS232 interface
9	Host Tail Line & ABS Box Connection Cable	4G-M	3G/4G main antenna interface
10		4G-D	3G/4G secondary antenna interface
11		GPS	GPS Antenna Interface
12		232/VBAT	Serial Port/Power Input
13	Accessory Cable	DC IN+, DC IN -, ACC	1. Power input interface; 2. DC9-36V power input, PON power supply;
14		S IN1、S IN2、S OUT1、GND	I/O interface : 2 inputs, 1 output, 1 GND
15		232RX、232TX	RS232 interface

## 5.2. Device Interface Diagram :

### 5.2.1. Z5 Host Interface

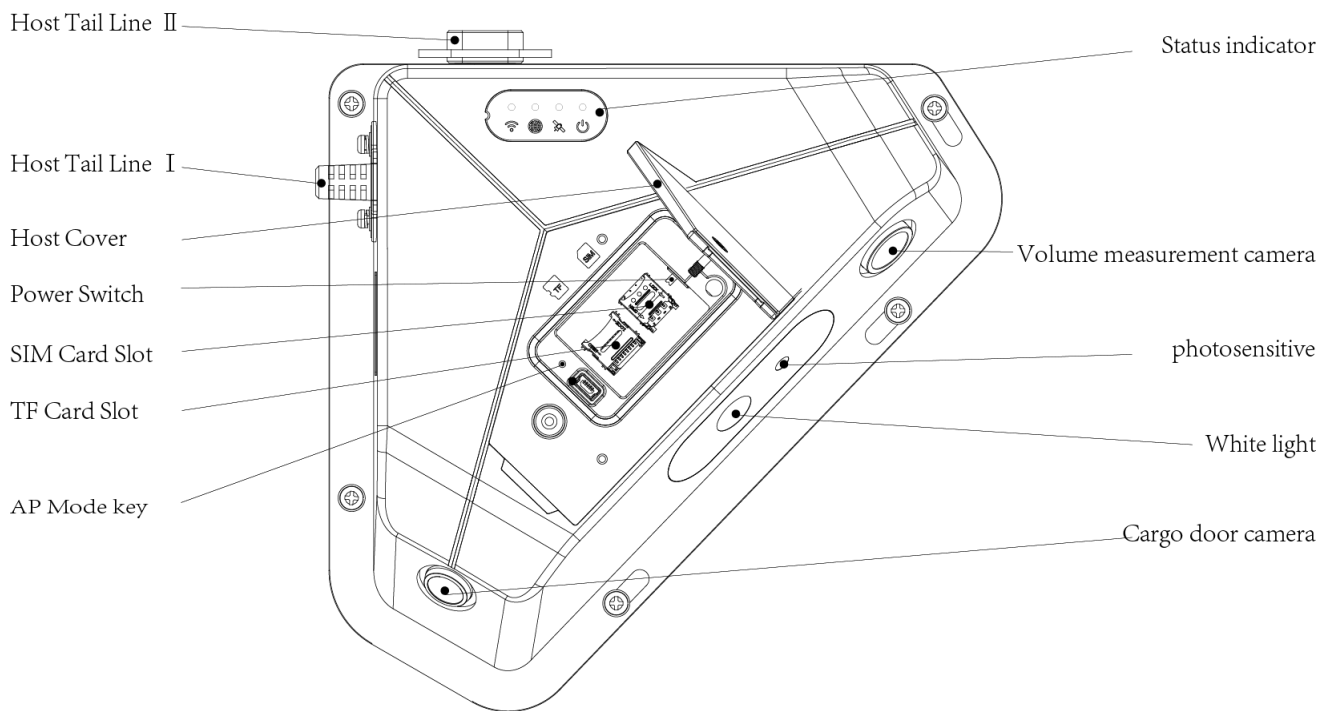

Host interface diagram

### 5.2.2. Host Tail Line I Interface

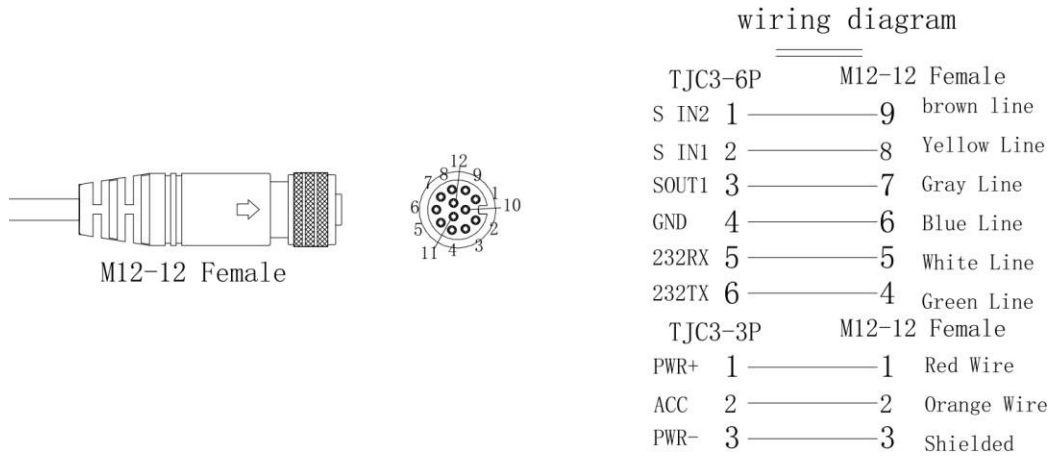

Host tail line I interface diagram

### 5.2.3. Host Tail Line II Interface

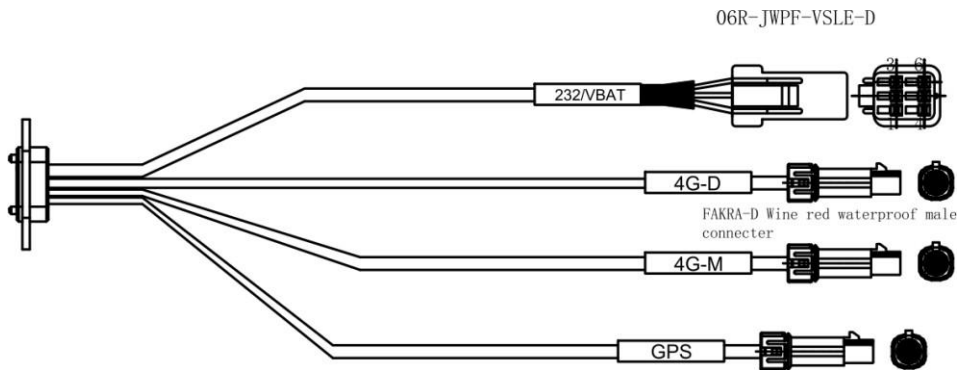

Host tail line II interface diagram

### 5.2.4. ABS Box External Interface

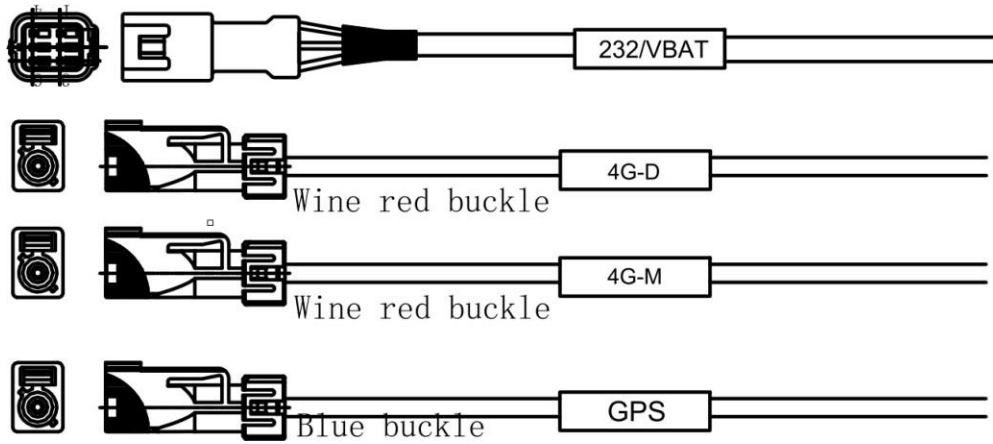

ABS box external interface diagram

### 5.2.5. Host and ABS Box Connection

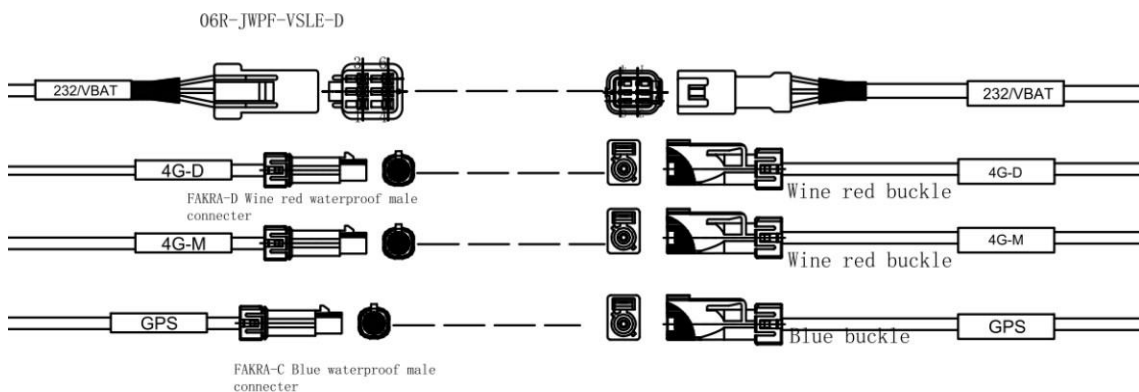

Host and ABS box connection diagram

### 5.2.6. Host Accessory Connection Cable

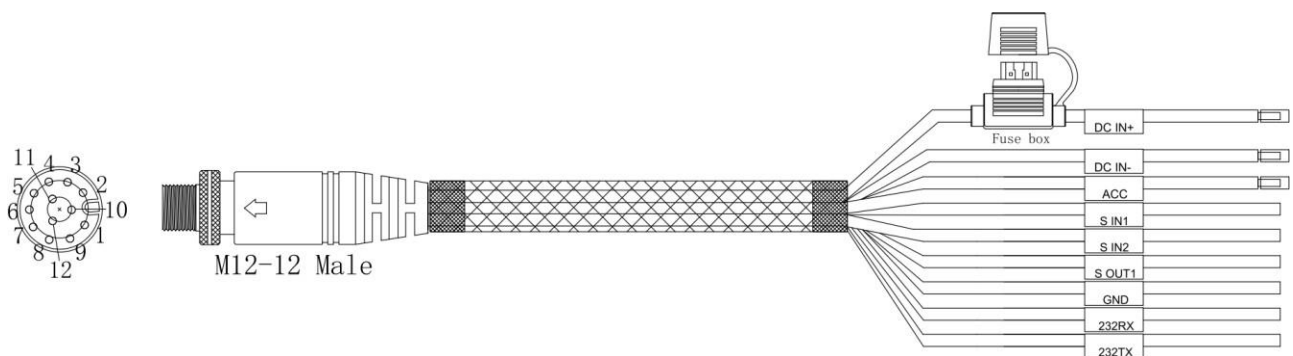

Accessory connection cable diagram

## 6.Product Installation

### 6.1. System Connection Diagram

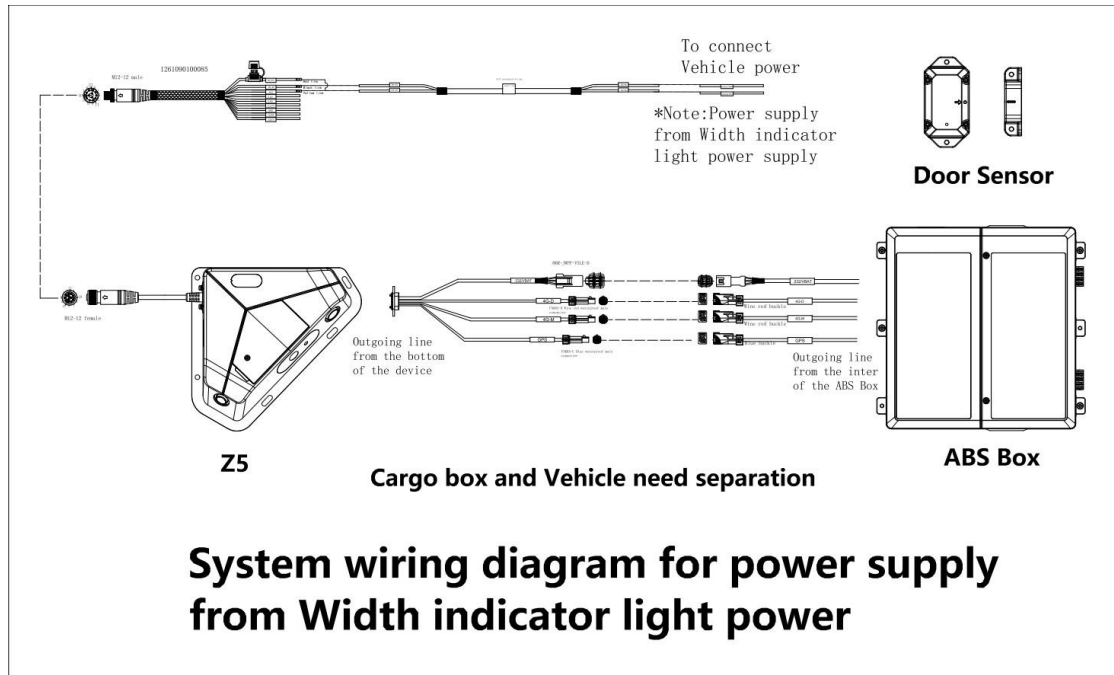

System connection diagram ( Powered from the width indicator light power )

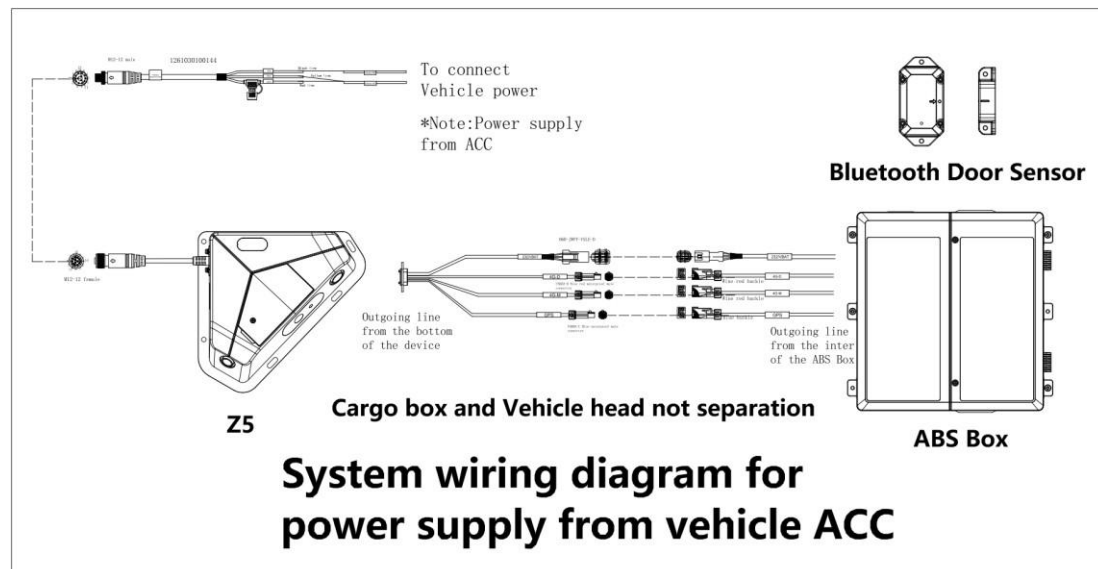

System connection diagram ( Powered from ACC power )