



MERIVA®
TECHNOLOGY

Streamax

Installation & User Guide

Product Model: MAVM-CLOTH

Contents

Revision history.....	¡Error! Marcador no definido.
Contents.....	2
1. Introduction	4
1.1 System Functions.....	4
1.2 Interface Introduction	5
2. System Composition.....	5
2.1 System Connection Diagram	5
2.2 Component Introduction	6
2.2.1 SVT-AVM Host	6
2.2.2 CA51 Cameras (4 pcs)	6
2.2.3 Main tail cable	7
2.2.4 Infrared receiver.....	7
2.2.5 Camera extension cable	7
2.2.6 CAN box.....	8
3. Calibration Tools	9
3.1 Calibration Cloth (4pcs)	9
3.2 Remote Controller	9
4. Installation Calibration	10
4.1 Hardware Installation.....	10
4.1.1 Camera installation	10
4.1.2 Vehicle signal Connection.....	14
4.2. Calibration.....	16
4.2.1 Preparation before calibration.....	16
4.2.2 Automatic calibration.....	18
4.2.3 Manual calibration.....	21
4.2.4 Road calibration optimization.....	23
5. System Functions and Control Description.....	25
5.1 View Switching Description	25
5.1.1 2D front view + around bird's eye view.....	25
5.1.2 2D rear view (reverse view) + around bird's eye view	25
5.1.3 2D left view (front) + around bird's eye view.....	26
5.1.4 2D left view (rear) + around bird's eye view	27
5.1.5 2D right view (front) + around bird's eye view	27
5.1.6 2D right view (rear) + around bird's eye view	28
5.1.7 2D vehicle body invisible view (front) + around bird's eye view	28
5.1.8 2D vehicle body invisible view (rear) + around bird's eye view.....	29
5.1.9 2D narrow lane view + around bird's eye view	29
5.1.10 2D front wide-angle view	30
5.1.11 2D rear wide-angle view	30

5.1.12 3D rear view + around bird's eye view	31
5.1.13 3D left rear view + around bird's eye view	31
5.1.14 3D right rear view + around bird's eye view	32
5.1.15 3D right view + around bird's eye view	33
5.1.16 3D left view + around bird's eye view	33
5.1.17 3D right front view + around bird's eye view	34
5.1.18 3D left front view + around bird's eye view	34
5.2 AVM Enabling and Disabling Strategy	35
5.2.1 AVM enabling display strategy	35
5.2.2 AVM disabling display strategy	35
5.2.3 AVM screen switching status logic	36
5.3 System Setup Guide.....	36
5.3.1 Display setup	36
5.3.2 Logic settings.....	39
5.3.3 System setup.....	42
5.3.4 Setting the video Output	43
6. Special Notes	44

1. Introduction

1.1 System Functions

The 360 Around View Monitor System (AVM) could combine and integrate the images from the 4 cameras (front/back/left/right) around the vehicle in real-time to form the 360° real-time image around the vehicle to eliminate or reduce the blind spots near the vehicle provide convenience and safety for users to park their vehicles, pass through narrow lanes, drive at low speed and turn to right and left.

Technically, AVM could output a bird's eye view around the vehicle body by stitching and fusing the images from four cameras, which is similar to a “God's eye” view around the vehicle; the fused view is not a true overhead plan view, and objects will be distorted due to the physical locations of the cameras. In addition, objects (pedestrians or vehicles) may be partially distorted in the video fusion area of adjacent cameras, because the images come from two cameras pointing in different directions. Due to the nature of the system, objects may not be displayed exactly where they are relative to the vehicle; the actual distance from any object may be shorter than it looks like. In particular, objects above the ground may be closer to the vehicle than they look like. Drivers should be alert to the presence of potential hazards.

Click to enable
transparent body

1.2 Interface Introduction

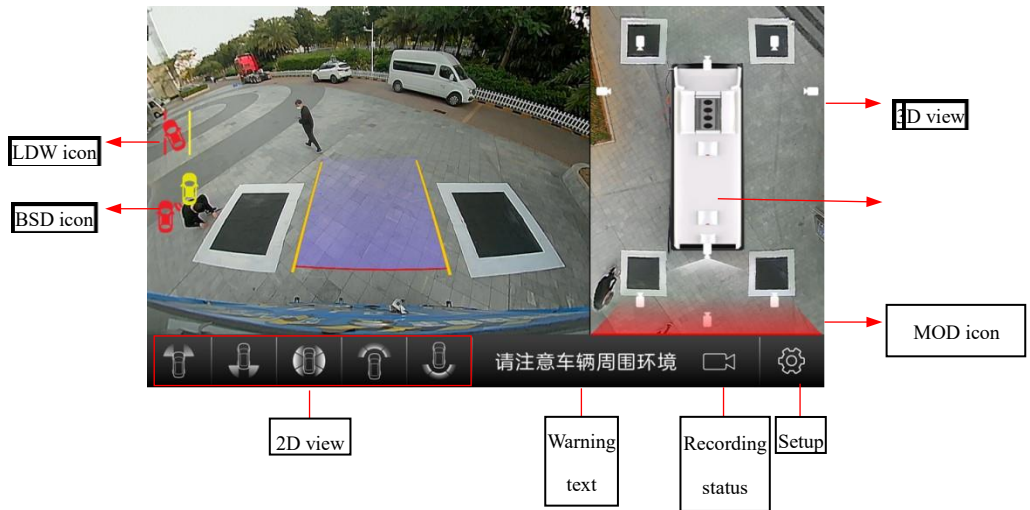

2. System Composition

2.1 System Connection Diagram

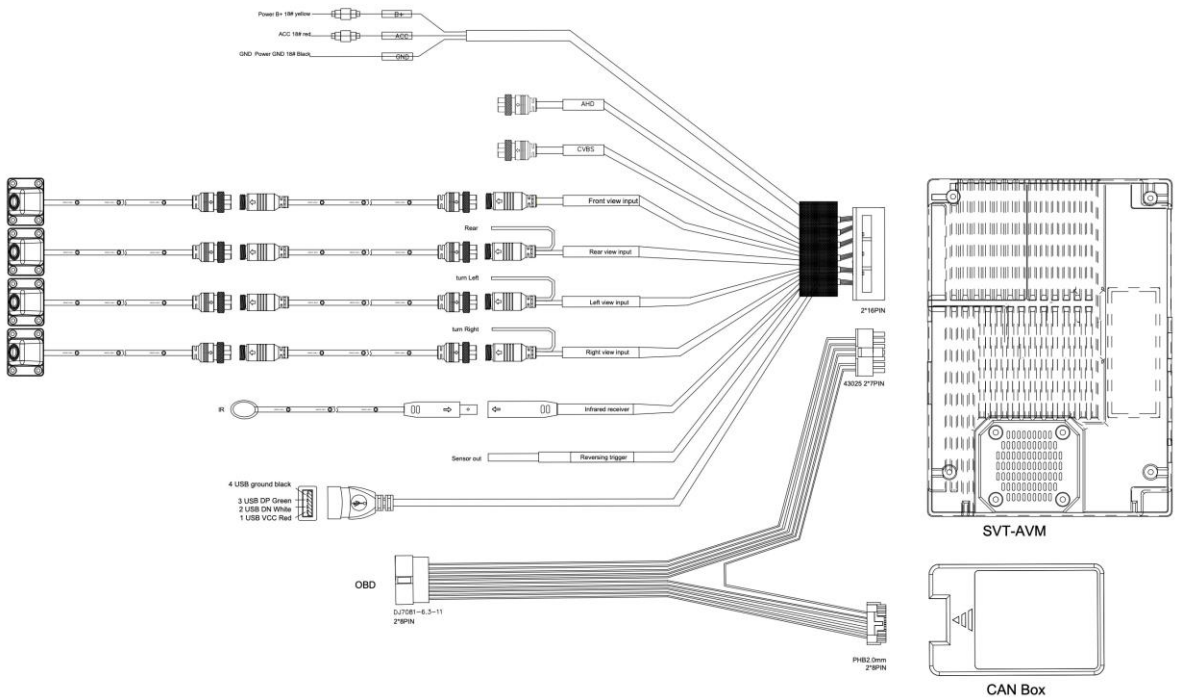

2.2 Component Introduction

2.2.1 SVT-AVM Host

SVT-AVM host is the component that connects cameras and display, which has video conversion, storage and other functions.



2.2.2 MCA51 Cameras (4 pcs)

Four fisheye cameras are installed in the front, rear, left and right of the vehicle to capture videos around the vehicle. For the SVT-AVM system, two fisheye cameras are available, namely, the angle-adjustable fisheye camera MCA51-S and the fixed-angle fisheye camera MCA51-X, which have the same optical characteristics but different structural appearances.



MCA51-X (F+B+L+R)



MCA51-S (L+R)

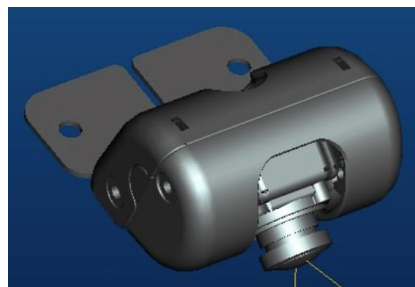

MCA51-S (F)

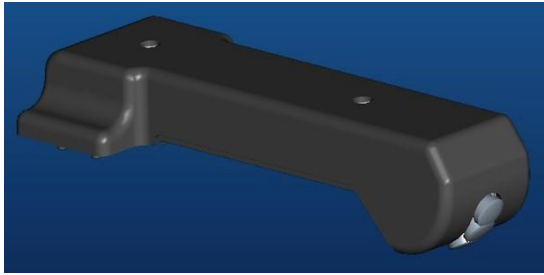

MCA51-S (B)

2.2.3 Main tail cable

The 32pin device tail cable provides camera port, U disk port, vehicle signal line port, IR receiver port and power port; please refer to the 32pin main tail cable drawing for more details.



2.2.4 Infrared receiver

The IR receiver is connected to the IR port of the main tail cable to receive signals from the remote controller.



2.2.5 Camera extension cable

The camera extension cable is 4pin aviation plug extension cable with the length selected according to different installation needs.



2.2.6 CAN box

When you need to use to MOD, BSD, LDW, transparent chassis, dynamic trajectory line, radar wall and other functions, you need to use the optional CAN box to get the vehicle information (speed, gear, steering wheel angle and radar signal).

Note: CAN box currently supports SAE and J1939 protocols. Due to vehicle differences, vehicle information may not be fully resolved and needs to be confirmed with a technician before use.



CAN box



CAN box wires

3. Calibration Tools

3.1 Calibration Cloth (4pcs)

Four calibration cloths shall be placed at the four corners of the vehicle in the splicing area to assist in the calibration process.

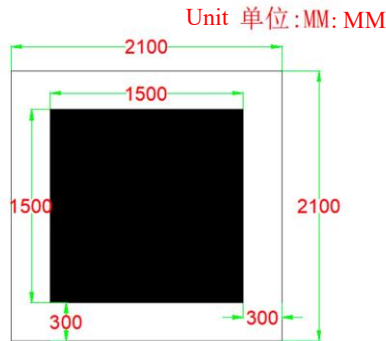

3.2 Remote Controller

The remote controller allows calibration, system setup and other operations with the following keys:

Display switch



Back/quit

Up/Down/Left/Right, confirm, body transparency switch

for

Number buttons that can be used for input

4. Installation Calibration

4.1 Hardware Installation

4.1.1 Camera installation

(1) Selection of camera installation positions

The installation positions of the 4 fisheye cameras are in the middle positions the four sides of the vehicle, which are close to the top of the vehicle (with the height of more than 2,000mm). It is recommended to install the cameras symmetrically in front and back, and symmetrically in left and right. The above installation requirements could not be met in some scenarios, which will not affect the normal operation of the system after calibration, but may affect the imaging under extreme conditions.

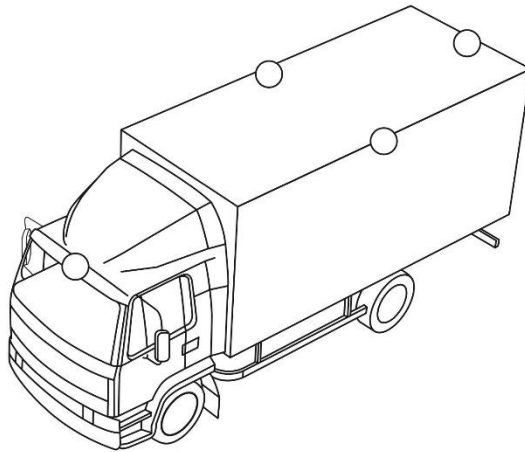

(2) Camera angle adjustment

For the SVT-AVM system, two fisheye cameras are available, namely, the angle-adjustable fisheye camera MCA51-S and the fixed-angle fisheye camera MCA51-X, which have the same optical characteristics but different structural appearances, as described in section 2.2.2.

MCA51-X camera is suitable for body mounted scenes perpendicular to the ground. After fixing MCA51-X, the body will occupy 10%~15% of the width at the bottom of the image.

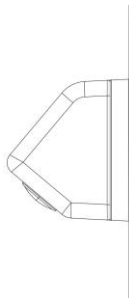

MCA51-X installed on vertical vehicle body

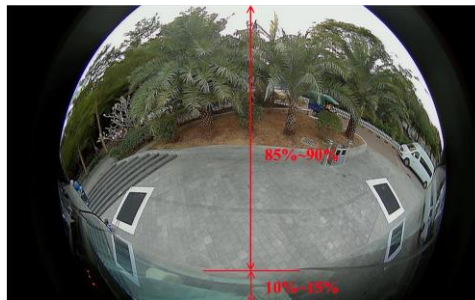

Vehicle body occupies 10% ~ 15% of the image width

Under some conditions, the vehicle body on which the camera is mounted is not perpendicular to the ground, so it is necessary to use the bracket provided by Streamax to correct the angle, so as to meet the requirement that the vehicle body occupies only 10%~15% in the image.

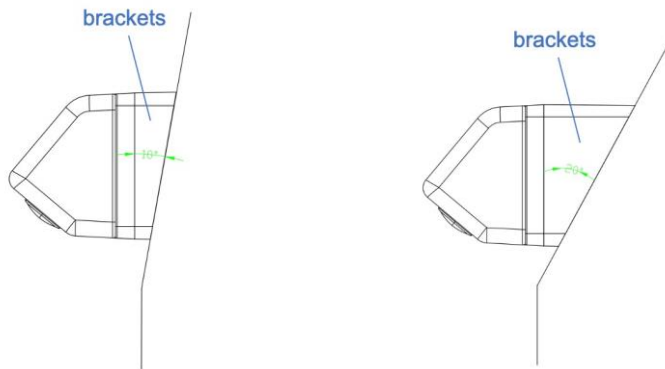

MCA51-S camera is suitable for installation on vehicle bodies with different tilting surfaces; after selecting a suitable location to install the MCA51-S camera, the angle of the camera's pitch-adjustable module lens component could be adjusted to meet the requirement that the body occupies 10% to 15% of the image. After the adjustment, use the tool to fix the side angle adjustment screws to ensure that the camera angle is stable and that the camera does not move.



Change the angle of MCA51-S



MCA51-S (F) in vehicles



MCA51-S (L) in vehicles



MCA51-S (B) in vehicles



MCA51-S (R) in vehicles

(3) Example of the correct installation of the camera

A. Installation of front camera



B. Installation of left and right cameras





C. Installation of rear camera



(4) Description of the blind area in AVM

Different camera installation methods will lead to different sizes of AVM blind zones. In an ideal vehicle, the front, left and right car bodies are flat without bumps and perpendicular to the ground. After the camera is installed, the body projection on the edge of the ground can be seen in a single screen. But the actual car body often has a camber (narrow roof, wide chassis), and there are door handles, rear view mirrors, bumpers and other raised parts of the block. The perfect way to do this is to use the bracket to mount the camera on the outermost edge of the vehicle. However, due to the aesthetics of the vehicle and the requirements of laws and regulations (the thickness of the bumps that installed lower than 2m on the exterior surface of the vehicle cannot exceed 10cm, and that installed higher than 2m cannot exceed the rearview mirror), the perfect installation scheme cannot be achieved.

Cameras mounted on cambered bodies often lead to a 10-20cm blind spot in the picture. According to the size of the camber, the size of the blind area is not different. As shown in the picture below, there is a 10cm wide blind area under the camera mounted on the cambered roof in the AVM system. There are 20cm wide blind spots in the front side and rear side of the car.



A blind spot in the middle of the side



A blind spot in the rear of the side

4.1.2 Vehicle signal Connection

(1) OBD Connection (vehicle speed acquisition)

The CAN box can be used to obtain the vehicle speed by connected to the vehicle's OBD interface; see section 2.2.6 for details of the CAN box and the connection method in the figure below.

Currently, CAN box supports parsing SAE+J1939 protocol speed acquisition. Please make sure the vehicle's CAN protocol is within the scope of this protocol.

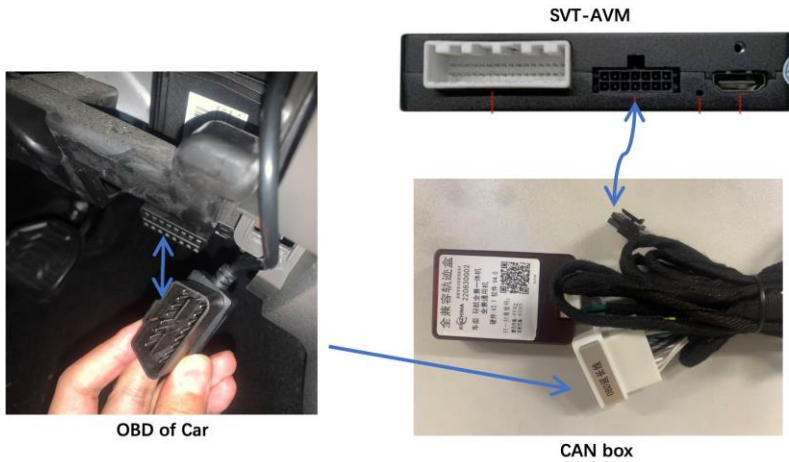

(2) Vehicle SENSOR_IN signal Connection (left turn, right turn, reverse)

The red wires from the left view, right view and rear view aviation plugs of the SVT_AVM main tail cable are respectively connected to the left turn, right turn and reverse signal lines of the vehicle as shown in the following figure.

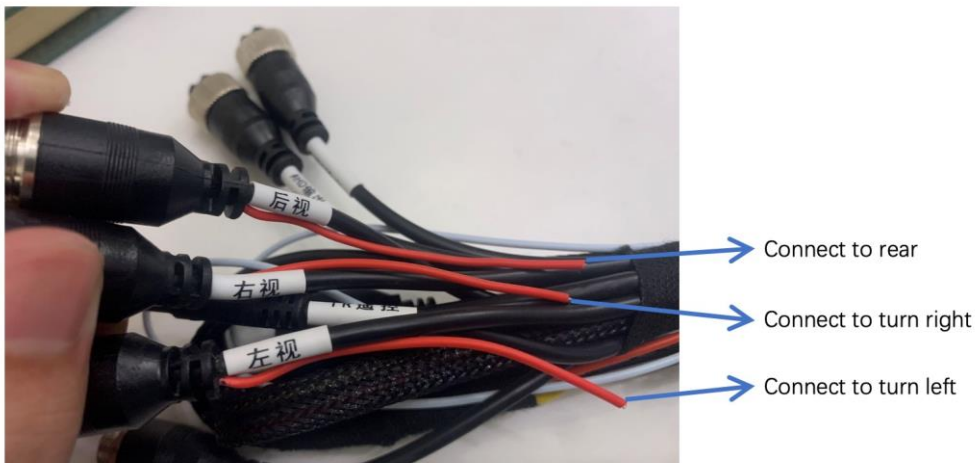

(3) Vehicle SENSOR_OUT signal Connection (enabling the central control panel of the vehicle)

When connecting the vehicle central control display, you need to control the linkage central control screen display 360 screen, and connect the SVT_AVM main tail line of the white SENSOR_OUT signal line to the control signal of the central control display. The wiring method is shown as follows:

The signal logic of SENSOR_OUT is as follows:

AV_OUT	SENSOR_OUT
With video output	1
Without video output	0

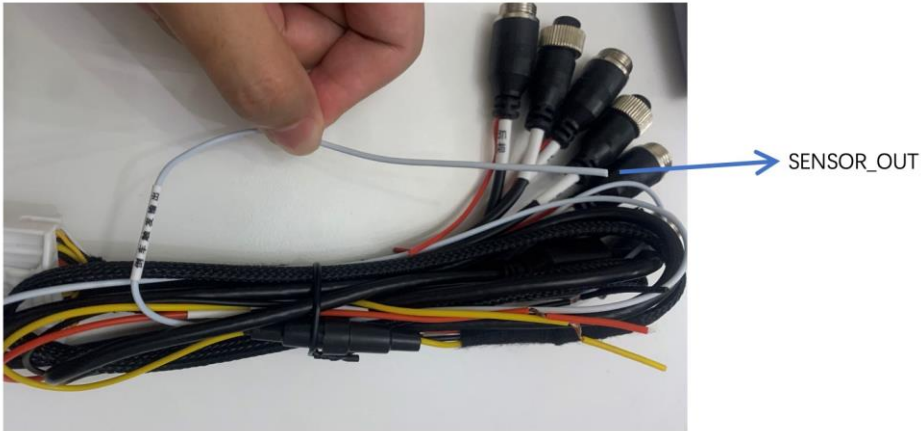

4.2 Calibration

4.2.1 Preparation before calibration

(1) Selection of calibration site

A flat site without significant slopes or unevenness shall be selected for calibration. To ensure that the automatic calibration functions properly, the site shall be in a solid color without obvious patterns or lane lines. The system shall not be adjusted under heavy sunshine or light or in places with shadows, which may cause the failure of automatic calibration.



Line signs on the ground



Shadows on the ground



Heavy sunshine

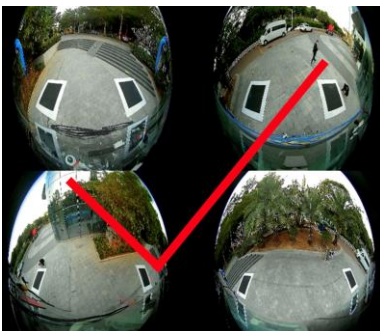

The site is OK

The calibration ground should be kept as flat as possible, and the height difference should be less than or equal to 5cm. If the ground height difference is greater than 5cm, the calibration may not fail, but the image stitching effect will be affected.

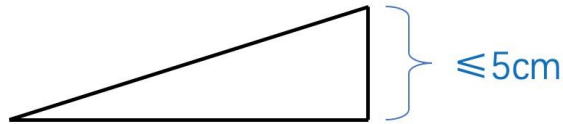

Site height difference requirements

(2) The requirements of lighting environment

To ensure the success of the automatic calibration process, ensure that the ambient illumination of the calibration is above 100Lux. Falling below this light condition may result in automatic calibration failure.



Minimum illuminance of automatic calibration

(3) Place the calibration cloths

Open positions around the vehicle at least 3 meters outward shall be selected for calibration, and the calibration site should meet the requirements of section 4.2.1(1).

You can use a 10-meter tape measure in front of and behind the vehicle, and ensure that straight line of the tape measure is parallel to the vehicle body at a distance of less than 30 cm. The specific position of the tape measure shall be determined according to the actual environment. In the calibration interface, the tape measure shall be fully visible and shall not be blocked by the vehicle body. After placing the tape measure correctly, put two calibration cloths in front of the vehicle and another two behind the vehicle, with the internal edge distance of 3.4m. The four calibration cloths shall be placed tidily as shown below.

The spacing between the inside edges of the calibration cloths on the front and rear sides of the vehicle is Length, and the width of the vehicle is width (the width is the width of the vehicle plug of widths of the left and right mirrors).

When you need to use the dynamic trajectory line function (currently only support two-axle vehicles), you need to measure the wheelbase and rear length of the vehicle, with the wheelbase as Wheel Base, and rear length as Rear Length.

The measurement diagram is shown in the figure below.

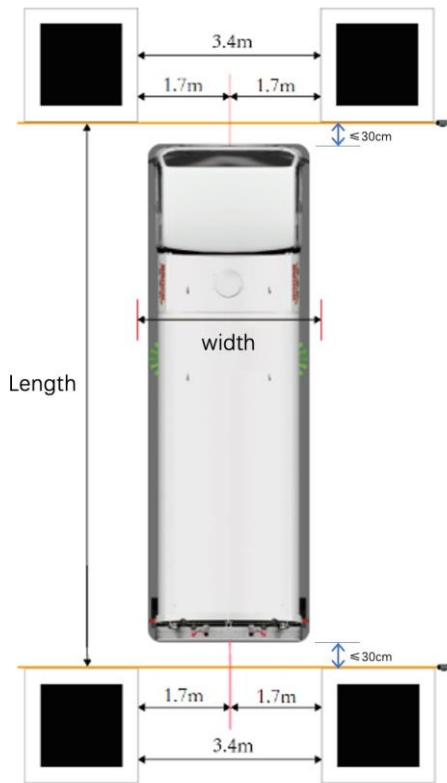

Diagram of arrangement of calibration cloths

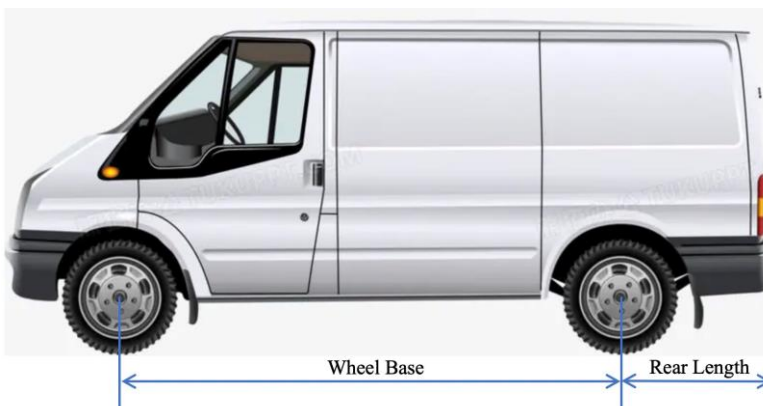
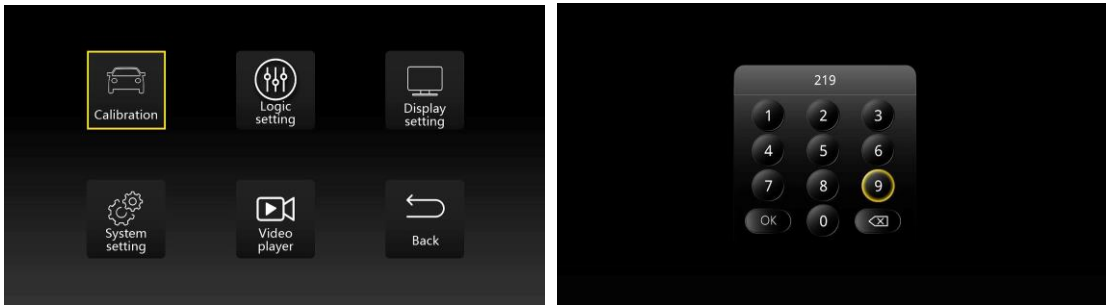

Diagram of measurement of wheel base and rear length

4.2.2 Automatic calibration

Open the “Set-Calibration”, and enter “219” to enter the calibration interface.



View the four-channel camera screen to determine whether the camera's installation angle is appropriate. If it is not, fine-tuning is required.

Check whether the calibration cloths could be seen clearly through all four channels, and if they cannot be seen clearly, the positions of the calibration cloths shall be adjusted.

Enter the values of Length (L), Width (W), WheelBase (WB) and RearLen (RL) manually



Click Scope (m): Use left and right arrows to choose the display range to stitch 2d top view. There are four options: 3 meters, 4 meters, 5 meters and 6 meters. The default option is 4 meters. Note: Different camera mounting heights may impact the picture stitching. To get a larger stitching field of view, you need to increase the camera mounting height.



Scope (m): the splicing range for 3 meters



Scope (m): the splicing range for 4 meters



Scope (m): the splicing range for 5 meters

Click the Auto button to start the automatic calibration. At this moment, the system will capture the current screen for the system to carry out calibration procedure at the back end, and the four calibration cloths shall not be blocked by obstacles or pedestrians, or the calibration will fail.

After the progress bar reaches the end, a pop-up window will be displayed to indicate the completion of the calibration.

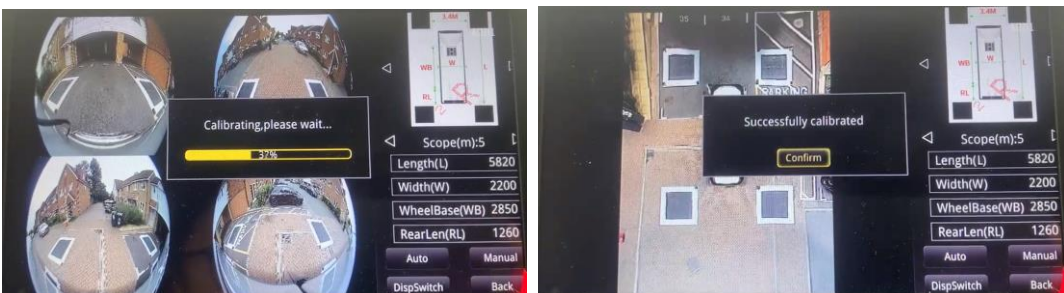

4.2.3 Manual calibration

In case of failure of the automatic calibration, manual calibration could be carried out. After manually entering vehicle information and selecting Scope (m), click Manual button to enter the manual calibration procedure.

When entering the manual calibration procedure, a pop-up window of Please Wait will be displayed, and the system will capture the current screen and carry out corner point recognition. After waiting for a short time, the system will enter the manual calibration interface.

Note: when the calibration cloths are blocked by obstacles or pedestrians when capturing the current screen, the system may not identify the corner points, resulting in a longer wait (≤ 1 min), which is normal, but will increase the whole calibration time. So please make sure that the calibration cloths are not blocked when you perform manual calibration.

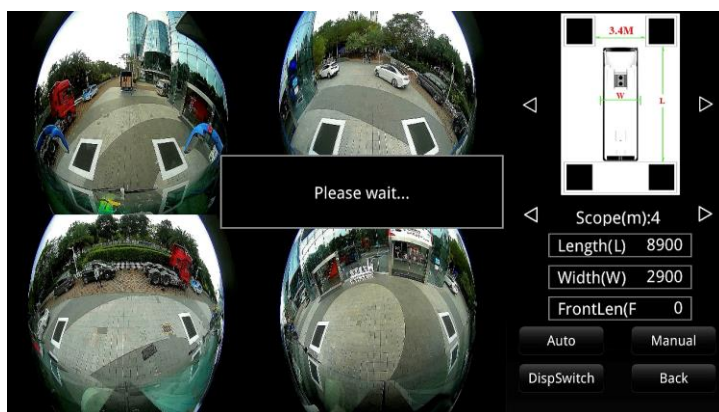

Upon entering the manual calibration interface, the system will display the front camera screen by default. The middle of the upper part of the screen is a partial zoom screen, helping the cursor to align the corner points; click the up, down, left and right buttons of the remote controller to move the cursor, click the "+/-" button of the remote controller to adjust the cursor movement step, with X1 for 1 times and X5 for 5 times; click "OK" to lock a cursor, and the cursor will change from red to green, and another cursor will be automatically placed; "undo" can be used to clear the locked cursors.



Corner points are selected from left to right. First select the left black frame, then select the right black frame. The points in the same black frame shall be selected in a Z pattern. In each screen, 8 corner points of the two calibration cloths shall be selected. After locking the 8 corner points in the current screen, the system will automatically move to the next screen, and the above operation shall be repeated.



After locking the corner points in the final screen, click “OK” to start manual calibration and a pop-up window will remind you to carry out the calibration.

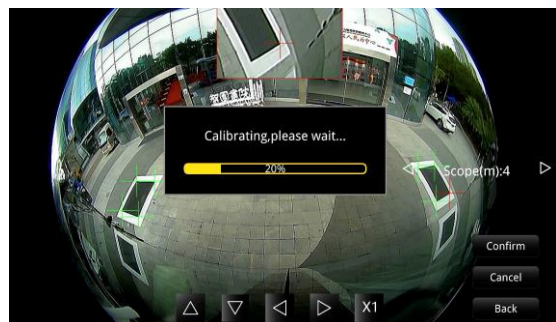

After completing the calibration, the calibration results will be displayed automatically.

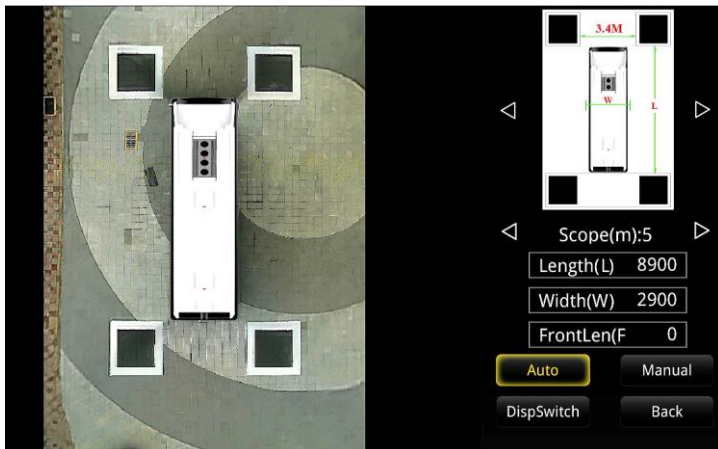

Calibration completed Click Back to quit to the around view screen.

Note: After the calibration is completed, there will be a transient black screen and delay ($\leq 7s$) when returning to the AVM. This is because the system is importing configuration parameters, and this phenomenon will only occur when the graphic parameters are changed.

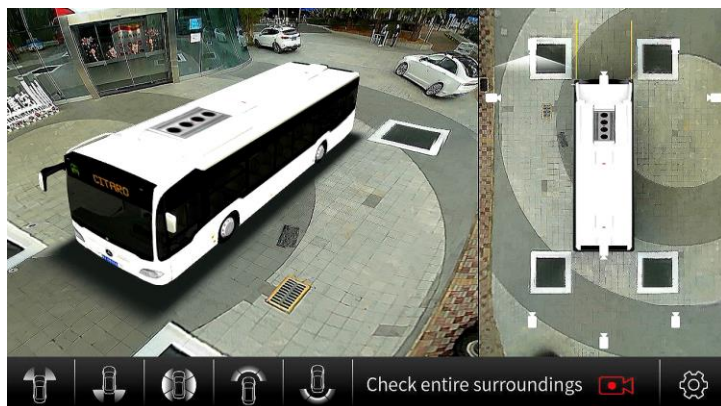

Return to the AVM

4.2.4 Road calibration optimization

For the image dislocation caused by the camera moving slightly after the calibration is completed, the road calibration optimization function can be used to correct the image dislocation. The steps are as follows:

Note: This function can only take effect when the picture is slightly misaligned. It cannot be used for calibration optimization when the picture is severely misaligned.

- (1) Open the double flash. (Need to access left and right turn signal)
- (2) The OK button of the remote control is pressed 6 times to open the road calibration mode.



- (3) Select the road condition with double solid lane line. After the vehicle runs straight along the middle of the road for a period of time at the speed of 10-30 km/h, then return the result automatically. (It can be completed in 15s or less in good condition, and longer in bad condition.)

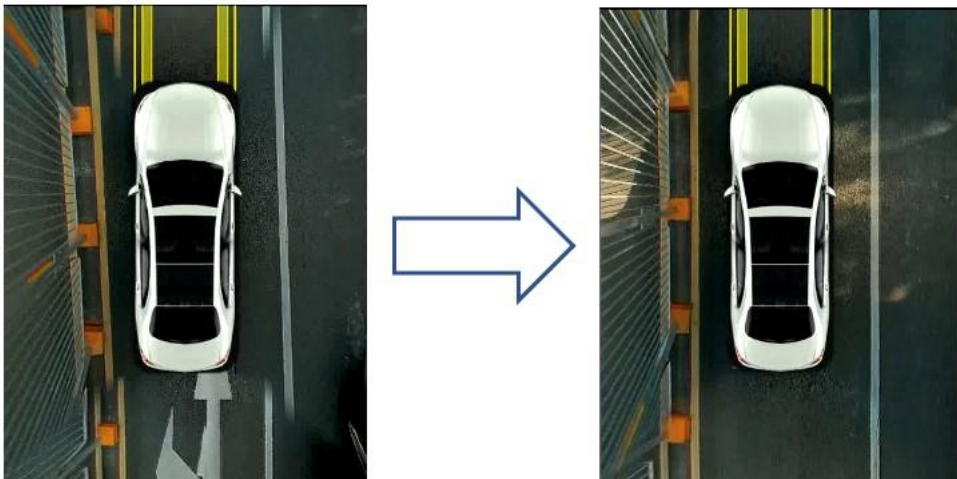

5. System Functions and Control Description

5.1 View Switching Description

5.1.1 2D front view + around bird's eye view

(1) Example diagram

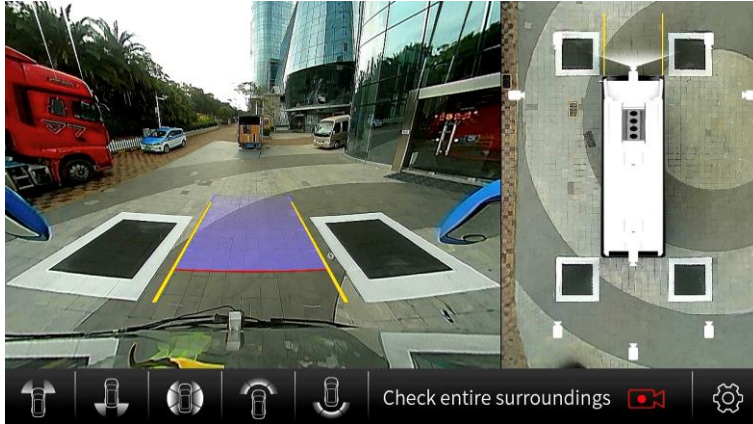

(2) Function description

A single front view camera image is shown on the left of the screen and an around bird's eye view is shown on the right.

Entry conditions:

1. Activate AVM to display 2D front view by default
2. Click on the front view icon
3. Exit from gear R
4. Press the left and right buttons on the remote controller to switch the views

5.1.2 2D rear view (reverse view) + around bird's eye view

(1) Example diagram

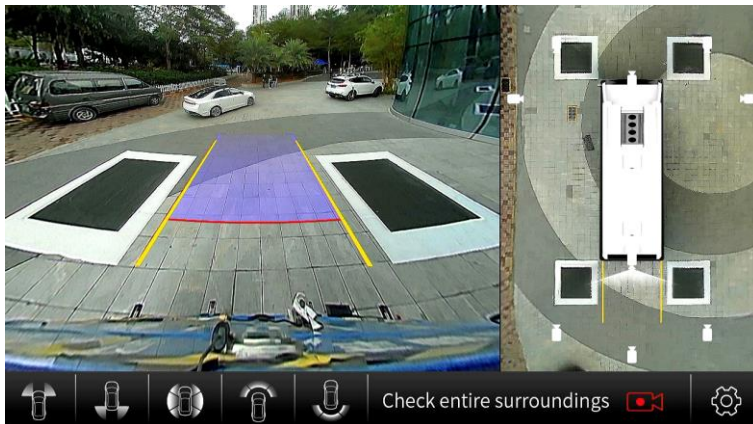

(2) Function description

A single rear view camera image is shown on the left of the screen and an around bird's eye view is shown on the right.

Entry conditions:

1. Gear R
2. Click on the rear view icon
3. Press the left and right buttons on the remote controller to switch the views

5.1.3 2D left view (front) + around bird's eye view

(1) Example diagram

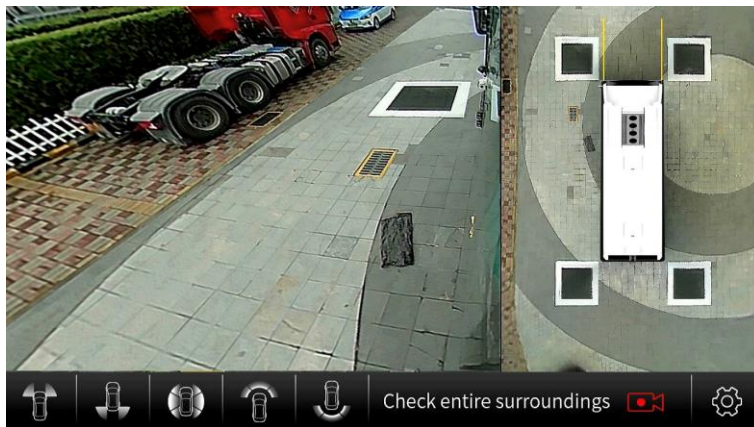

(2) Function description

The front view of the single left view camera image is shown on the left of the screen and an around bird's eye view is shown on the right.

Entry conditions:

1. In system setup, set the steering switching to 2D, front view and turn on left turn signal

5.1.4 2D left view (rear) + around bird's eye view

(1) Example diagram

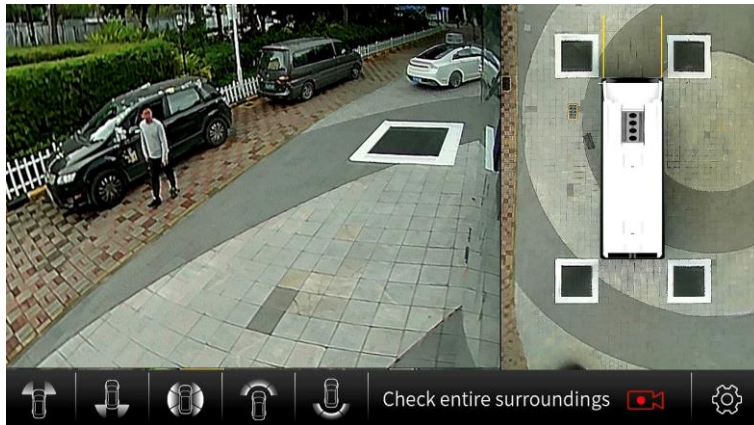

(2) Function description

The rear view of the single left view camera image is shown on the left of the screen and an around bird's eye view is shown on the right.

Entry conditions:

1. In system setup, set the steering switching to 2D, rear view and turn on left turn signal

5.1.5 2D right view (front) + around bird's eye view

(1) Example diagram

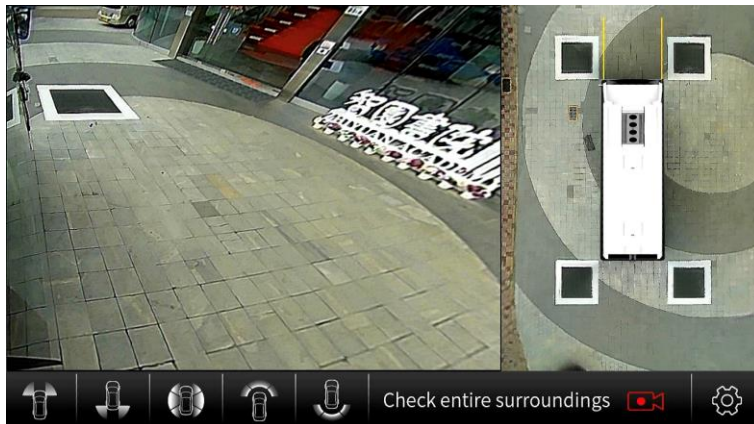

(2) Function description

The front view of the single right view camera image is shown on the left of the screen and an around bird's eye view is shown on the right.

Entry conditions:

1. In system setup, set the steering switching to 2D, front view and turn on right turn signal

5.1.6 2D right view (rear) + around bird's eye view

(1) Example diagram

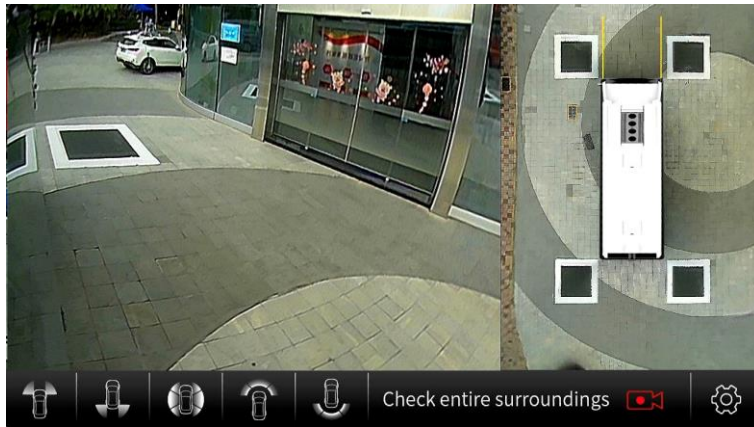

(2) Function description

The rear view of the single right view camera image is shown on the left of the screen and an around bird's eye view is shown on the right.

Entry conditions:

1. In system setup, set the steering switching to 2D, rear view and turn on right turn signal

5.1.7 2D vehicle body invisible view (front) + around bird's eye view

(1) Example diagram

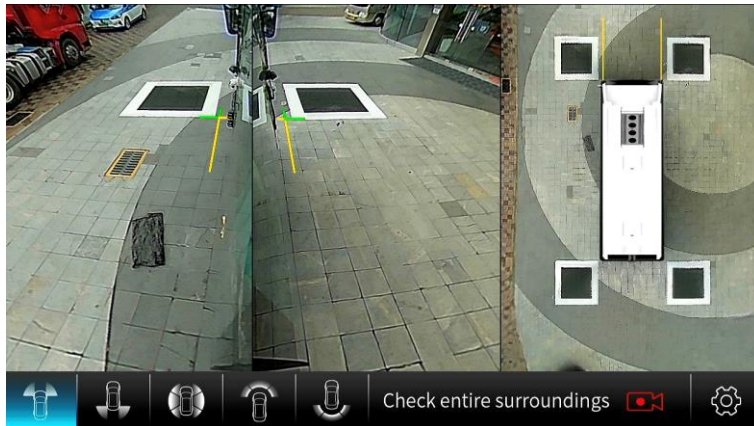

(2) Function description

The left side of the screen is an image made up with two forward views of the left and right sides of the vehicle, with the body being flattened, and the right side is an around bird's eye view.

Entry conditions:

1. In system setup, set the steering switching to 2D, front view and turn on double flash
2. Click on the front blind spot view icon
2. Press the left and right buttons on the remote controller to switch the views

5.1.8 2D vehicle body invisible view (rear) + around bird's eye view

(1) Example diagram

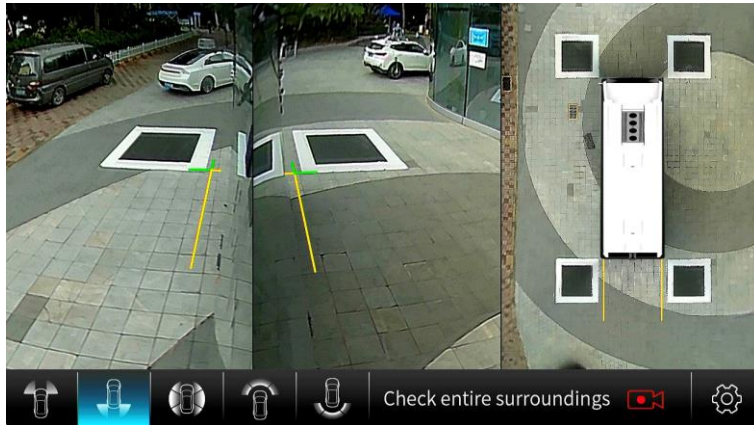

(2) Function description

The left side of the screen is an image made up with two rear views of the left and right sides of the vehicle, with the body being flattened, and the right side is an around bird's eye view.

Entry conditions:

1. In system setup, set the steering switching to 2D, rear view and turn on double flash
2. Click on the rear blind spot view icon
2. Press the left and right buttons on the remote controller to switch the views

5.1.9 2D narrow lane view + around bird's eye view

(1) Example diagram

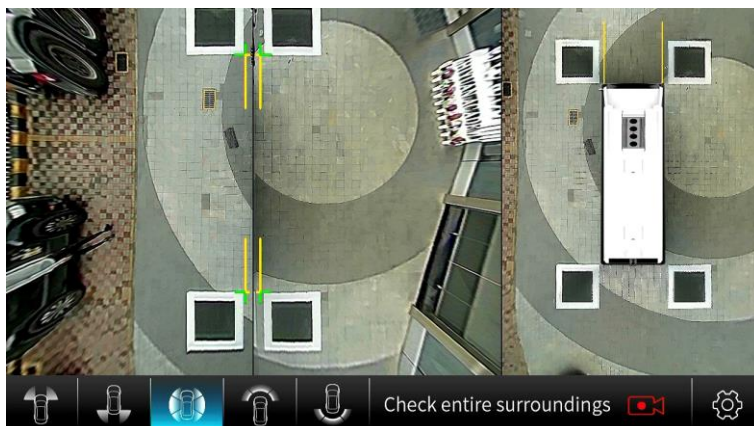

(2) Function description

The left side of the screen is an image made up with two top views of the left and right sides of the vehicle, with the body being flattened, and the right side is an around bird's eye view.

Entry conditions:

1. Engage in gear R and turn on double flash
2. Click on the narrow lane top blind spot view icon
3. Press the left and right buttons on the remote controller to switch the views

5.1.10 2D front wide-angle view

(1) Example diagram

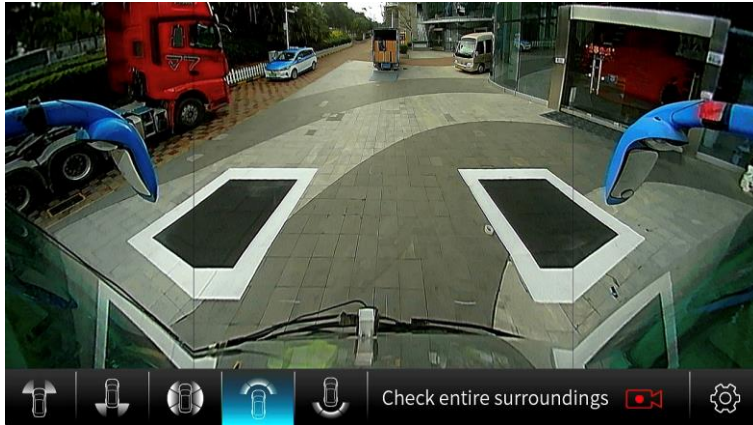

(2) Function description

The entire screen is a forward-facing wide-angle view of the vehicle, which is stitched with three images.

Entry conditions:

1. Click on the front wide-angle view icon
2. Press the left and right buttons on the remote controller to switch the views

5.1.11 2D rear wide-angle view

(1) Example diagram

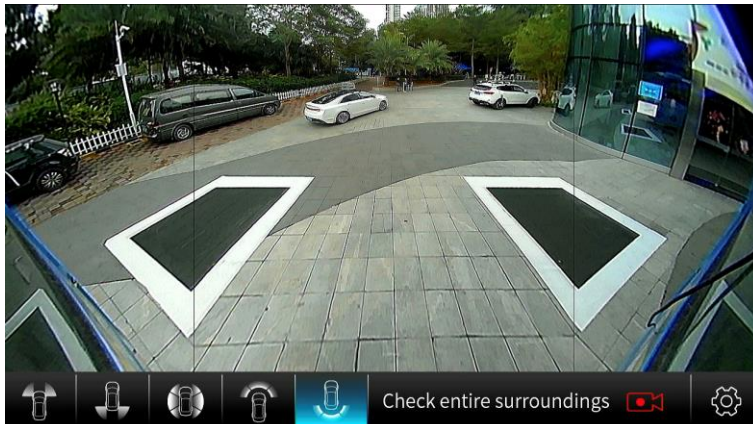

(2) Function description

The entire screen is a backward-facing wide-angle view of the vehicle, which is stitched with three images.

Entry conditions:

1. In system setup, set the steering switching to 2D, rear wide-angle view and turn on left/right turn lamps/double flash
2. Click on the rear wide-angle view icon
3. Press the left and right buttons on the remote controller to switch the views

5.1.12 3D rear view + around bird's eye view

(1) Example diagram

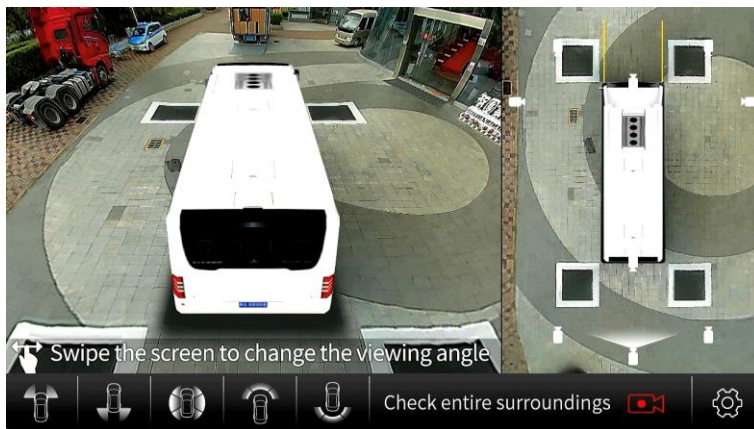

(2) Function description

The left side of the screen shows the 3D front view of the vehicle, and the right side shows the around bird's eye view.

Entry conditions:

1. Click on the 3D rear view icon
2. Press the left and right buttons on the remote controller to switch the views

5.1.13 3D left rear view + around bird's eye view

(1) Example diagram

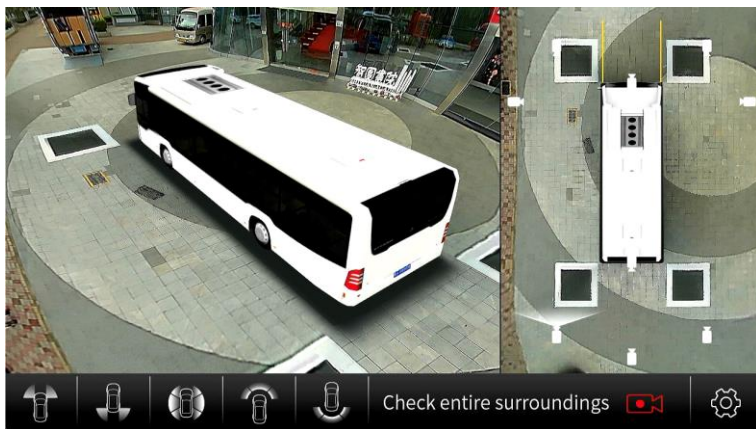

(2) Function description

The left side of the screen shows the 3D left rear view of the vehicle, and the right side shows the around bird's eye view.

Entry conditions:

1. In system setup, set the steering switching to 3D, rear view and turn on left turn lamp
2. Click on the 3D left rear view icon
3. Press the left and right buttons on the remote controller to switch the views

5.1.14 3D right rear view + around bird's eye view

(1) Example diagram

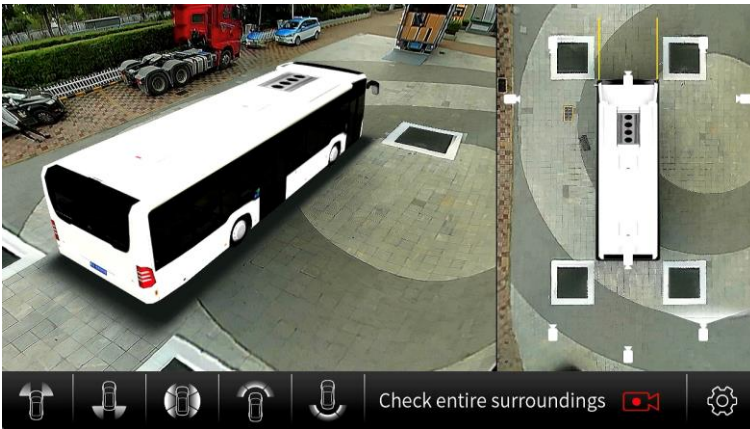

(2) Function description

The left side of the screen shows the 3D right rear view of the vehicle, and the right side shows the around bird's eye view.

Entry conditions:

1. In system setup, set the steering switching to 3D, rear view and turn on right turn lamp
2. Click on the 3D right rear view icon
3. Press the left and right buttons on the remote controller to switch the views

5.1.15 3D right view + around bird's eye view

(1) Example diagram

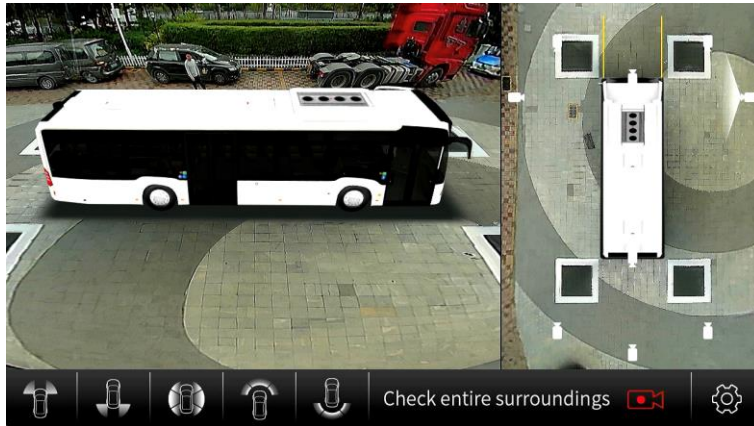

(2) Function description

The left side of the screen shows the 3D right view of the vehicle, and the right side shows the around bird's eye view.

Entry conditions:

1. Click on the 3D right view icon
2. Press the left and right buttons on the remote controller to switch the views

5.1.16 3D left view + around bird's eye view

(1) Example diagram

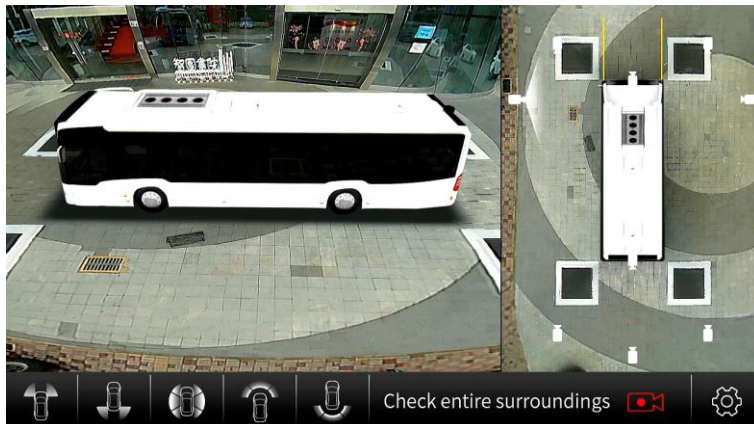

(2) Function description

The left side of the screen shows the 3D left view of the vehicle, and the right side shows the around bird's eye view.

Entry conditions:

1. Click on the 3D left view icon
2. Press the left and right buttons on the remote controller to switch the views

5.1.17 3D right front view + around bird's eye view

(1) Example diagram

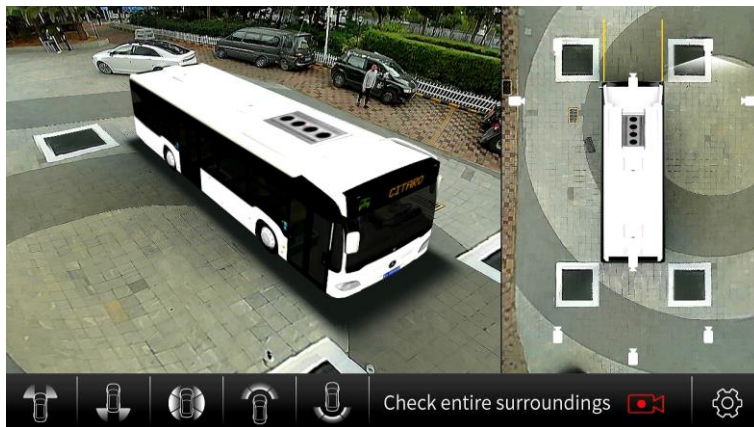

(2) Function description

The left side of the screen shows the 3D right front view of the vehicle, and the right side shows the around bird's eye view.

Entry conditions:

1. In system setup, set the steering switching to 3D, front view and turn on right turn lamp
1. Click on the 3D right front view icon
2. Press the left and right buttons on the remote controller to switch the views

5.1.18 3D left front view + around bird's eye view

(1) Example diagram

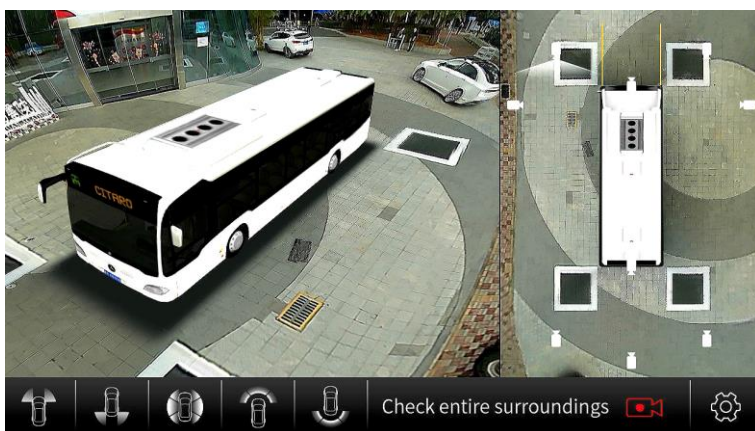

(2) Function description

The left side of the screen shows the 3D left front view of the vehicle, and the right side shows the around bird's eye view.

Entry conditions:

1. In system setup, set the steering switching to 3D, front view and turn on left turn lamp

2. Click on the 3D left front view icon
3. Press the left and right buttons on the remote controller to switch the views

5.2 AVM Enabling and Disabling Strategy

5.2.1 AVM enabling display strategy

1. AVM is enabled after powering on the system by default
2. Turn on double flash
3. Gear R
4. Left turn/right turn
5. After selecting radar trigger conditions, the AVM will be enabled when the radar detects targets

5.2.2 AVM disabling display strategy

1. If a delay quit logic is set, the system will quit after reaching the set time

5.2.3 AVM screen switching status logic

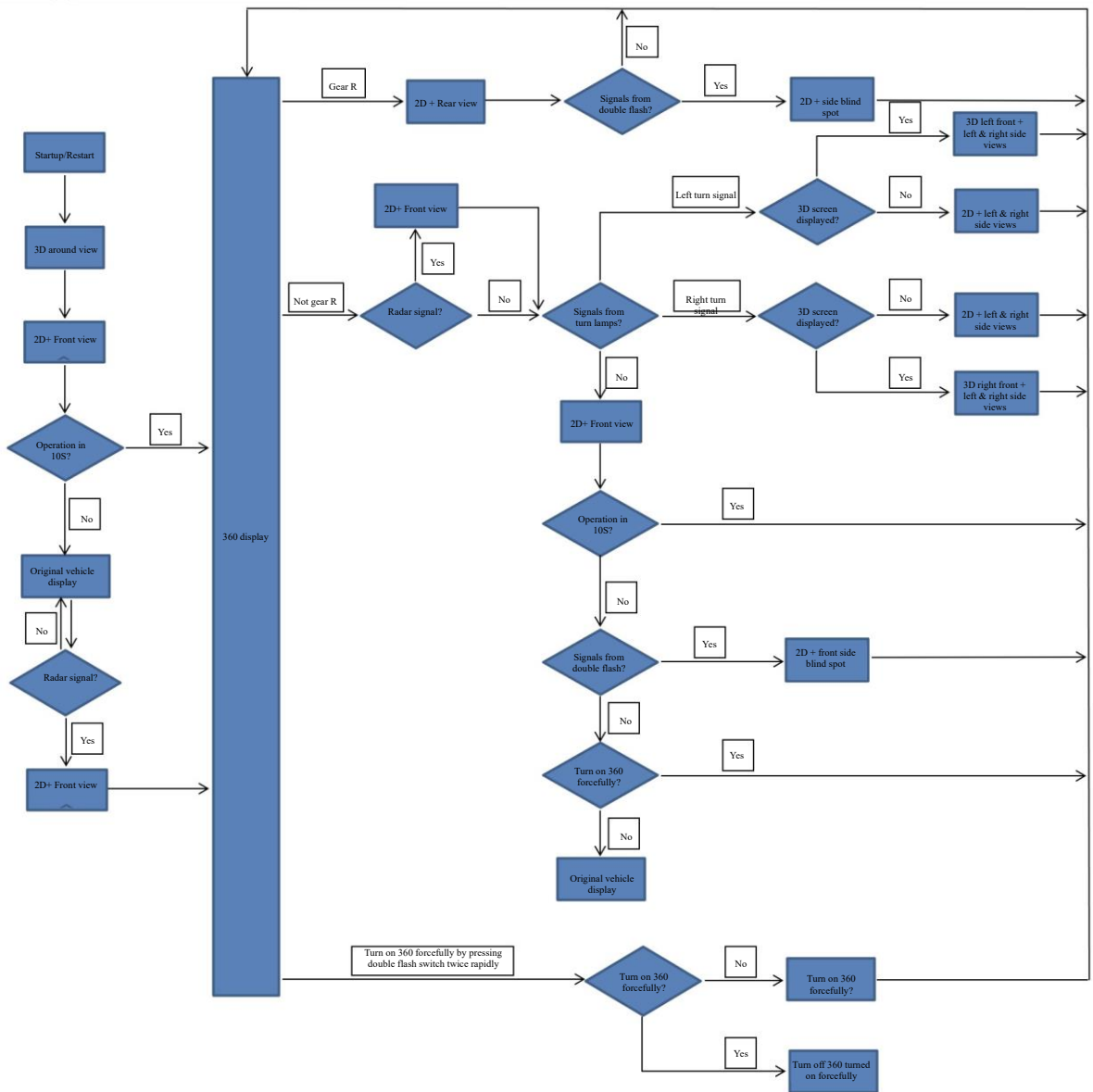

5.3 System Setup Guide

5.3.1 Display setup

Open setup option, and enter Display setting interface.

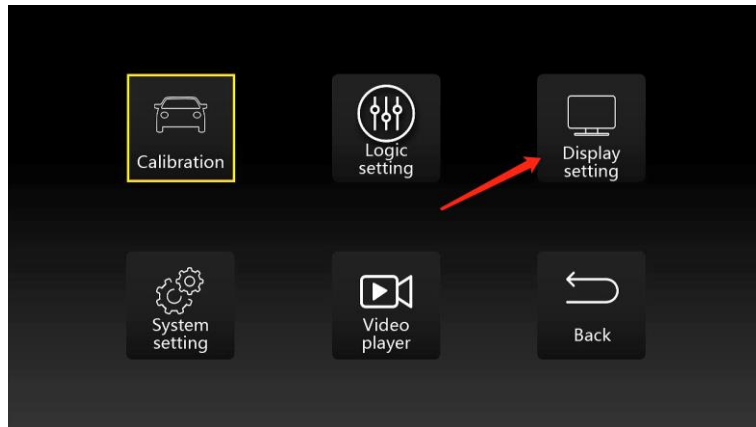

(1) Screen setting

The edge position of the display screen can be adjusted up, down, left and right according to the current display status to reach the best display effect.

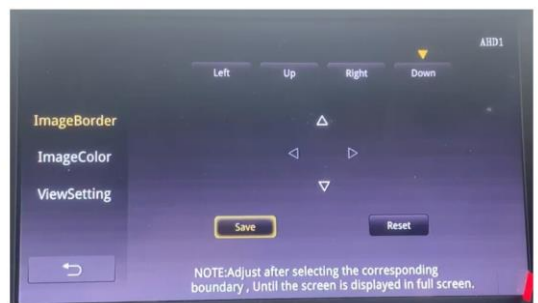
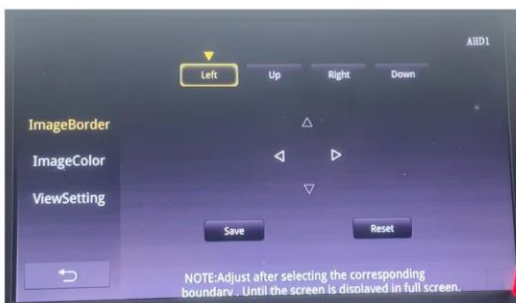
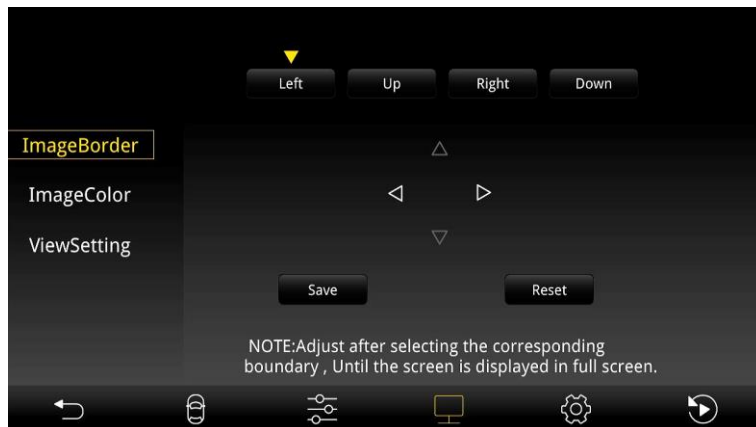

(2) Screen color setting

You can adjust the color, brightness, contrast, sharpness and other parameters of the camera channel screen.



(3) View setting

In the view settings, you can adjust the 2D front view, 2D rear view, 2D left view (front), 2D left view (rear), 2D right view (front), 2D right view (rear), 2D vehicle body invisible view (front), 2D vehicle body invisible view (rear), 2D narrow lane view, 2D front wide-angle view, 2D rear wide-angle view and 3D view respectively, as shown in an example here.

A. Switching between the original screen and corrected screen

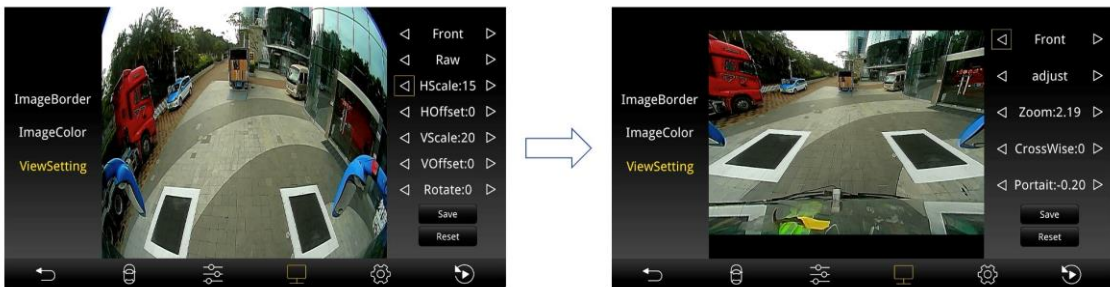

B. Vertical scaling

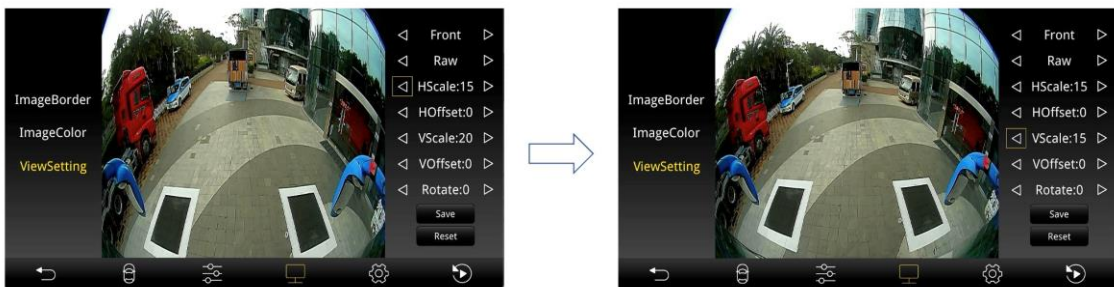

C. Horizontal scaling



D. Horizontal movement



E. Vertical movement



F. Rotation



5.3.2 Logic settings

Open setup option, and enter logic setting interface.

(1) Control setting

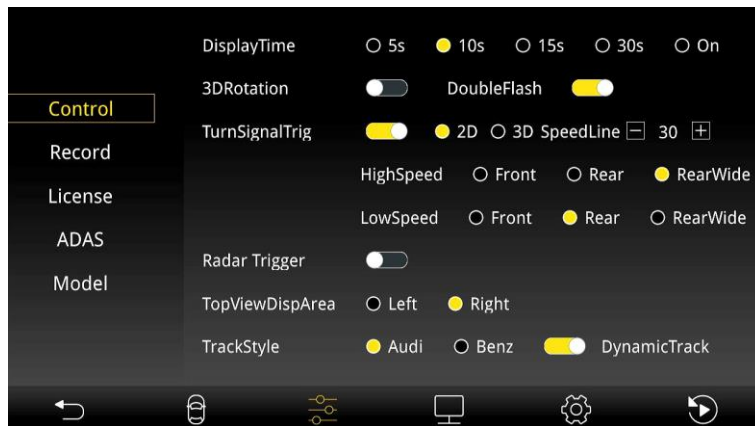

Display Time: The time for the control system to exit AVM display, which can be set to 5s, 10s, 15s, 30s or always on.

3D Rotation: Enabling - Enable the 3D AVM model rotation function

Double Flash: Enabling - turn on double flash, and trigger it to turn on AVM display

TurnSignalTrig: Configure the single view screen of left and right turn signal switching. You can configure whether to turn on or not, set the high and low speed threshold, trigger the turn view as 2D or 3D, trigger the front view, rear view and rear wide view in 2D mode, trigger the front view and rear view in 3D mode.

Radar Trigger: Enabling - radar triggers AVM display

TopViewDispArea: Set the around bird's-eye view to the left or right side

(2) Recording Settings

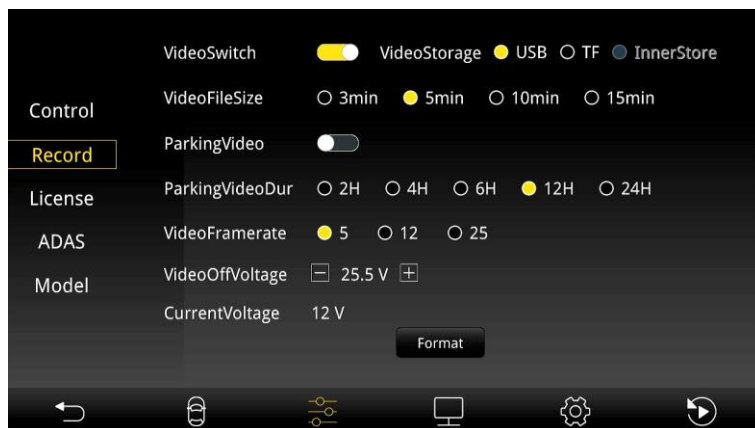

Video Switch: Enabling - turn on the video recording function

Video Storage: To select the storage device for video recording, USB/TF/internal storage

Video File Size: To set the length of each recorded video to 3min/5min/10min/15min

Parking Video: Enabling - Keep recording videos after turning off the vehicle

Parking VideoDur: Keep recording videos after turning off the vehicle

Video Framerate: Video recording frame rate setting, 5fps/12fps/25fps

VideoOffVoltage: The setting of recording off voltage. If the voltage is lower than the set value, the recording will be disabled

Current Voltage: Current voltage of the device

(3) License plate setting



(4) ADAS setting

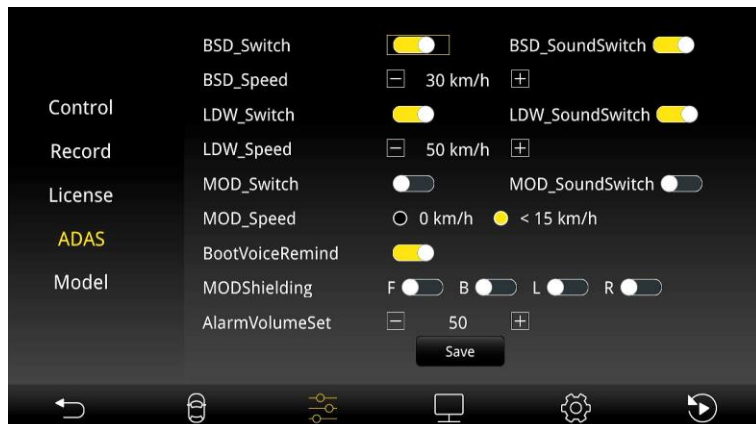

BSD Switch: Enabling - turn on the BSD alarm function

BSD Sound Switch: Enabling - turn on the BSD alarm sound

BSD Speed: To set the vehicle speed threshold to enabling BSD. If the vehicle speed is higher than the set value, the BSD will work

LDW Switch: Enabling - turn on the LDW alarm function

LDW Sound Switch: Enabling - turn on the LDW alarm sound

LDW Speed: To set the vehicle speed threshold to enabling LDW. If the vehicle speed is higher than the set value, the LDW will work

MOD Switch: Enabling - turn on the MOD alarm function

MOD Sound Switch: Enabling - turn on the MOD alarm sound

MOD Speed: To set the vehicle speed threshold to enable BSD. 0 means that MOD works only when the vehicle is not moving. <15km/h means that the vehicle speed shall be lower than 15km/h to enable MOD

MOD Shielding: Enabling - turn off single side MOD alarm

AlarmVolumeSet: To set system sound volume

(5) Vehicle model setting



5.3.3 System setup

Open setup option, and enter system setting interface.

(1) Time setting (You need to set the time for the initial power-on)

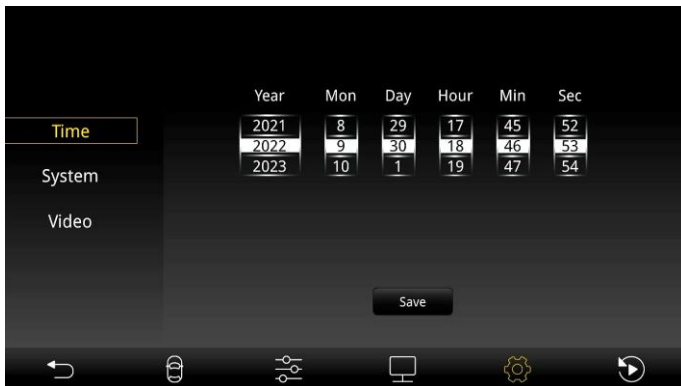

(2) System setting



Language: To set system language as Simplified Chinese, English or Traditional Chinese After setting the language, the system will reboot.

Control Method: To set control method, and remote controller is selected by default

Data Import/Export: To import/export calibration parameters

At this point, corresponding storage device shall be selected in Control Setting - Recording Setting - Recording Storage, and the default import/export route of calibration parameters is the selected storage device. When a USB flash drive is selected for import/export, after switching to a USB storage device and returning to the home page, the system will ask if you want to format the drive. Select No, and the parameters could be imported/exported.

Update: To update system software and MCU software

Put the update file into the update folder in the USB flash drive, select USB as the storage and click the button to update the system software.

System Version: System software version information

MCU Version: MCU software version information

(3) Video interface

This function is not available



5.3.4 Setting the video Output

Using DIP switch to set the video output signal, you can set the video output format, resolution and other information.

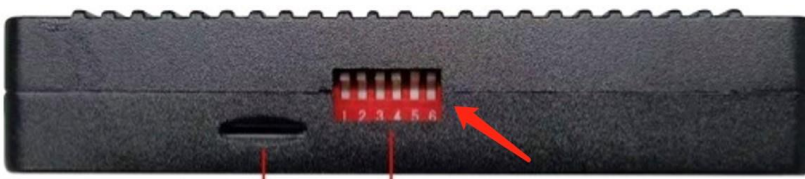
The setting method is as shown in the picture below:



Location of switch

The rules of Outputs			Picture of the switch		
output	number of SW	1	2	all "ON" 	
	rules				
AHD or TVI or AV		OFF	ON	all "OFF" 	
HDMI		ON	ON		
VGA		ON	OFF		
depends on the setting item or serial port protocol		OFF	OFF		
The rules of Resolution of the output					
resolution	number of SW	3	4	5	6
	rules				
720*480		ON	OFF	OFF	OFF
720*576		OFF	OFF	ON	ON
800*480		ON	ON	ON	ON
960*480		OFF	OFF	OFF	OFF
1024*480		OFF	ON	OFF	ON
1280*480		ON	ON	OFF	ON
960*540		OFF	ON	ON	OFF
1280*540		OFF	ON	OFF	OFF
1440*540		ON	ON	ON	OFF
800*600		OFF	OFF	ON	OFF
1024*600		OFF	OFF	OFF	ON
1280*640		ON	OFF	OFF	ON
1280*720		ON	ON	OFF	OFF
1540*720		ON	OFF	ON	ON
1920*720		OFF	ON	ON	ON
1920*1080		ON	OFF	ON	OFF
AV_NTSC		ON	OFF	OFF	OFF
AV_PAL		OFF	OFF	ON	ON
AHD_720P_25fps		ON	ON	ON	ON
AHD_720P_30fps		ON	ON	OFF	ON
AHD_1080P_25fps		ON	ON	ON	OFF
AHD_1080P_30fps		ON	ON	OFF	OFF
depend on the software protocol 1		OFF	OFF	OFF	OFF
		OFF	OFF	OFF	ON

The settings table of Video output

6. Special Notes

This product shall be installed by professionals, otherwise there will be risk of electric shock or damage to vehicle wiring, affecting the use of the device.

