

Installation and Setup Guide

GENERAL INFORMATION

The ADEMCO 6160RF keypad/transceiver is a combination unit that combines the functions of the following devices:

- 6160 Alphanumeric Addressable Keypad
- 5881H RF Receiver
- 5800TM Transmitter Module

The 6160RF Keypad/Transceiver may be used on any control panel that supports 5800 Series wireless devices (e.g., VISTA-10P, VISTA-15P, and VISTA-20P).

FEATURES

- Supports wireless key transmitters (e.g.; 5834-4) and bi-directional transmitters (e.g.; 5828/5828V).
- Supports wireless keys with high-security (encryption) capability (e.g.; 5834-4).
- Provides a nominal range of 200 feet for RF transmitters (some transmitters have a shorter range).
- Supports RF jam detection when the receiver is enabled.
- Capable of sending status signals (Armed, Ready, etc.) to bi-directional units such as 5828/5828V.

UL

The following 5800 series transmitters are not intended for use in UL installations: 5802WXT, 5834-4, 5834-4EN, 5814, 5819, 5819BRS, 5819WHS, and 5828/5828V.

INSTALLING THE 6160RF

Locate the 6160RF in an area and at a height where it is convenient for user operation. The 6160RF must be at least 10 ft from the control panel to ensure proper operation of the RF receiver.

Mounting and Wiring

The 6160RF has terminal blocks for connection to power and data wires. Removing the keypad's case back provides access to the terminal blocks.

The 6160RF can be surface mounted directly to walls, or to a single- or double-gang electrical box. Follow these steps to mount and wire the keypad:

1. Push the two case release snaps at the bottom of the keypad with the blade of a medium screwdriver (this will push in the release snap), then pull that side of the case back away. Insert the screwdriver in the side of the keypad (between the front and back case) and gently twist to release the side locking tab. Repeat for the other side. Refer to Figure 1 for location of the case back release snaps and locking tabs.

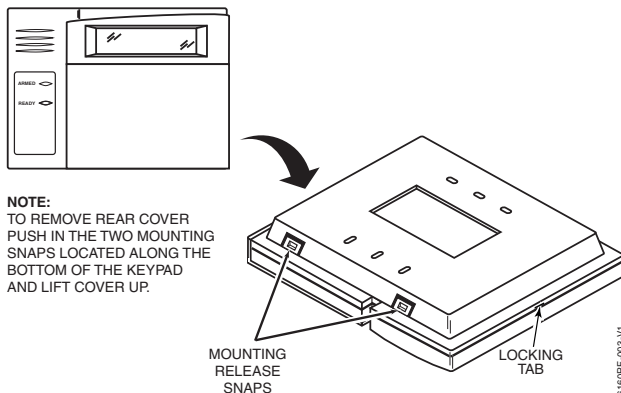

Figure 1. Removing the Case Back

2. Pass the wiring from the control panel through the opening in the case back. (see the control panel's instructions for proper run lengths.)
 - a. If surface wiring is being used, wiring may be routed through the top or the bottom left-side breakout in the case back. The breakouts must be punched out using a screwdriver before mounting the case back.
 - b. If desired, wires may be strain-relieved to the wire tie point on the inside of the case back with a tie wrap (not supplied).
3. Mount the case back to a wall or to an electrical box using the 25mm-long self-tapping screws supplied (mollies for drywall are not supplied).
4. Connect the power and data wires from the control panel to the terminals on the 6160RF as indicated in Figure 2 and Table 1.

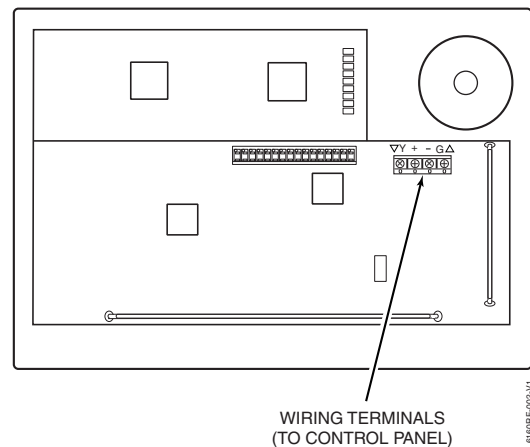

Figure 2 - 6160RF Wiring Details

Table 1 - Wiring Table

Keypad	Control Panel	Wire Color
G▼ (Data Out)	Data In	Green
-	-Aux Pwr (GND)	Black
+	+Aux Pwr	Red
▲Y (Data In)	Data Out	Yellow

5. Reattach the keypad to the mounted case back. Attach the top of the keypad first, and then press the bottom section down until it snaps into place securely.
6. Peel off protective film on the LED panel and install the

APPLICATION GUIDELINES FOR THE 6160RF

Use the following guidelines when planning an installation:

If...	And...	Then...
This is the only transceiver on the system,	You want to use both the receiver and transmitter function on a single-partition system,	<ul style="list-style-type: none"> • Set the keypad to a device address assigned to the desired partition.* • Enable the receiver. • Program a system House ID in the control panel (this will enable the transmitter function).** • Set the wireless devices that will communicate with this 6160RF to the same system House ID.
There is another receiver or transceiver on the system,	You want to use only the transmitter function on a second partition,	<ul style="list-style-type: none"> • Set the keypad to a device address assigned to the desired partition.* • Disable the receiver. • Program a DIFFERENT House ID in the 6160RF than is programmed in the control panel.* / ** • Set the wireless devices that will communicate with this 6160RF to the same House ID as the 6160RF.
	You want to use only the transmitter function on a single-partition system,	<ul style="list-style-type: none"> • Set the keypad to a device address assigned to the Partition 1. • Disable the receiver. • Program a House ID in the 6160RF that matches the system House ID programmed in the control panel.* • Set the wireless devices that will communicate with this 6160RF to the same House ID.

Notes:

* On VISTA-40 panels and above, wireless keypads (e.g., 5804BD) can only be used on a single partition. This partition is programmed in field 1*48, and must match the partition assigned to the 6160RF. Wireless keys can be used on more than one partition, using a House ID programmed in the 6160RF and the devices. In this case, the wireless keys must be assigned to the same partition as the 6160RF.

** On VISTA-20P panels, the 6160RF will use the House ID programmed in the panel for the partition to which it is assigned. Wireless keypads can only be used on Partition 1.

PROGRAMMING THE 6160RF

Refer to the following procedure to program the 6160RF:

STEP	DESCRIPTION	DISPLAY	CHOICES
1.	Enter the program mode by pressing the [1] and [3] keys simultaneously for a few seconds within 60 seconds after applying power.		
2.	(Keypad Address) Enter the two-digit keypad address. Press the [*] key to continue. Notes: (1) Refer to the control panel's installation instructions for the acceptable keypad addresses. (2) On the VISTA-40 and above the 6160RF's partition assignment must match the RF keypad partition assignment programmed in field (1*48).	<i>CON ADDRESS = XX</i>	00-31
3.	(Receiver Enable) Enter [1] to enable, or [0] to disable Receiver. Enable the receiver if RF transmitters or wireless keypads are programmed into the control and no other receivers are enabled. Press the [*] key to continue.	<i>RECEIVER ON [0= OFF]</i>	1= ON 0 = OFF
4.	(Receiver Address) If receiver is enabled, enter the two-digit receiver address. (00-30). Note: Refer to the control panel's installation instructions for the acceptable receiver addresses. Press the [*] key to continue.	<i>REC ADDRESS= XX</i>	00-30
5.	(House ID) This prompt will only appear if the receiver is disabled. If the receiver is enabled the 6160RF will use the House ID programmed in the panel. Refer to Application Guidelines section when selecting a House ID. To program a House ID: Enter 01-31. To disable the transmitter: Enter 00 Note: Each device that will receive status from the 6160RF must be set to the same House ID as the 6160RF (refer to Application Guidelines section). Press the [*] key to continue.	<i>HOUSE ID = XX</i>	00-31

STEP	DESCRIPTION	DISPLAY	CHOICES
6.	(Enable High Security Mode) Enter [1] to select High Security Mode. Note: If the High Security mode is enabled, the 6160RF will only recognize encrypted devices. If this mode is disabled, the 6160RF will process commands both encrypted and non-encrypted devices. Press the [*] key to continue.	<i>HIGH SECURITY OFF [1] = ON</i>	1 = Enable 0 = Disable
7.	(Disable High Security Devices) Press the [*] key to skip this prompt and exit Program Mode. Notes: (1) The [*] key must be pressed several times in order to save the programmed data. (2) If you need to disable encrypted devices, refer to the Disabling High Security Devices section.	<i>DISABLE HS DEV? NO [1] = YES</i>	1 = YES 0 = NO

ACTIVATING HIGH SECURITY DEVICES

This following procedure should be followed if using High-Security (encrypted) devices.

STEP	DESCRIPTION
1.	Follow the normal procedure for programming the device into the control panel (refer to the Installation Instructions for the device that you are programming). Exit out of Programming Mode.
2.	Put the control panel in Go/ No Go Test mode. (See the Installation Guide for the panel being installed.)
3.	Follow the instructions supplied with each wireless device to enroll the device in High-security mode. After each device is enrolled the 6160RF will momentarily display "SECURE DEVICE" along with the device number and its serial number. Note: The 6160RF will support a maximum of 8 devices. If you attempt to enroll additional devices the keypad will display "EXCEEDED NUMBER" "ALLOWED DEVICES".

DISABLING HIGH SECURITY DEVICES

This mode gives you the ability to disable high security on all wireless keys that have been enrolled in the 6160RF. This is particularly useful if a user loses a wireless key.



Once high-security (encrypted) devices have been disabled, they will only operate if the 6160RF is set to listen to both encrypted and non-encrypted devices (programming step 6, above). To completely disable the devices, they must be deleted from the control panel.

STEP	DESCRIPTION	DISPLAY	CHOICES
1.	After the keypad has been powered for at least 60 seconds hold down the [1] and [3] keys at the same time for 3 seconds. The current keypad address will be displayed. (You cannot change the keypad's address at this point.) Press the [*] key to continue.	<i>CON ADDRESS=XX</i>	00-31
2.	(Delete High Security Devices) Press the [1] key to remove all high-security (encrypted) devices. Press the [*] key to continue.	<i>DISABLE HS DEV? NO [1]=YES</i>	1 = YES 0 = NO
3.	If YES was selected in Step 2 the unit will display a confirm request to delete the stored high security device. Press the [1] key to accept, followed by the [*] key to exit the programming mode.	<i>ARE YOU SURE? NO [1]=YES</i>	1 = YES 0 = NO

TROUBLESHOOTING

The error messages listed in the following table cause the 6160RF to produce a single ding tone. The table describes the error messages and the corrective actions.

Display	Probable Cause	Corrective Action
Low Bat (with zone no.)	Low battery in the wireless device.	1. Replace the battery if the wireless transmitter has a replaceable battery. 2. Replace the transmitter if the wireless transmitter does not have a replaceable battery.
Open Ckt	No data is being received from the control panel.	Verify that the keypad ▲Y (yellow) wire is connected properly.
Check 100 Check 1xx*	1. The control panel does not see the 6160RF Receiver, or the Receiver is not functioning. 2. Another device on the keypad terminals is not communicating to the control panel.	1a. Verify that the keypad ▲Y (yellow) and G▼ (green) wires are connected properly. 1b. Verify that the control's receiver address is correct. 2. Verify the wiring connections between the control and all other devices.

*xx= the device address of the receiver.

SPECIFICATIONS

Physical: 5-3/8" H x 7-3/8" W x 1-1/4" D
(137mm x 187mm x 32mm)

Wiring: Refer to Table 1

Range: 200 ft (60.9 m) nominal

Frequency: 345 MHz

Current: Standby 50mA

Backlighting on and

Sounder on 150mA

Display: 2 x 16 alphanumeric supertwist LCD, backlit

Sounder: Tone Generator Integrated Circuit. (fire alarm is loud pulsing tone; burglary/audible panic alarm is continuous tone)

REFER TO THE INSTALLATION INSTRUCTIONS FOR THE CONTROL WITH WHICH THIS DEVICE IS USED, FOR DETAILS REGARDING LIMITATIONS OF THE ENTIRE ALARM SYSTEM.

Federal Communications Commission (FCC) Part 15

The user shall not make any changes or modifications to the equipment unless authorized by the Installation Instructions or User's Manual. Unauthorized changes or modifications could void the user's authority to operate the equipment.

FCC CLASS B STATEMENT

This equipment has been tested to FCC requirements and has been found acceptable for use. The FCC requires the following statement for your information:

This equipment generates and uses radio frequency energy and if not installed and used properly, that is, in strict accordance with the manufacturer's instructions, may cause interference to radio and television reception. It has been type tested and found to comply with the limits for a Class B computing device in accordance with the specifications in Part 15 of FCC Rules, which are designed to provide reasonable protection against such interference in a residential installation. However, there is no guarantee that interference will not occur in a particular installation. If this equipment does cause interference to radio or television reception, which can be determined by turning the equipment off and on, the user is encouraged to try to correct the interference by one or more of the following measures:

- If using an indoor antenna, have a quality outdoor antenna installed.
- Reorient the receiving antenna until interference is reduced or eliminated.
- Move the radio or television receiver away from the receiver/control.
- Move the antenna leads away from any wire runs to the receiver/control.
- Plug the receiver/control into a different outlet so that it and the radio or television receiver are on different branch circuits.
- Consult the dealer or an experienced radio/TV technician for help.

FCC/IC STATEMENTS

This device complies with Part 15 of the FCC rules and RSS-210 of Industry Canada. Operation is subject to the following two conditions: (1) This device may not cause harmful interference, and (2) This device must accept any interference received, including interference that may cause undesired operation.

Cet appareil est conforme à la partie 15 des règles de la FCC & de RSS-210 des Industries Canada. Son fonctionnement est soumis aux conditions suivantes: (1) Cet appareil ne doit pas causer d'interférences nuisibles. (2) Cet appareil doit accepter toute interférence reçue y compris les interférences causant une réception indésirable.

This Class B digital apparatus complies with Canadian ICES-003.

Cet appareil numérique de la classe B est conforme à la norme NMB-003 du Canada.

Responsible Party / Issuer of Supplier's Declaration of Conformity: Ademco Inc., a subsidiary of Resideo Technologies, Inc., 2 Corporate Center Drive., Melville, NY 11747, Ph: 516-577-2000

The product should not be disposed of with other household waste. Check for the nearest authorized collection centers or authorized recyclers. The correct disposal of end-of-life equipment will help prevent potential negative consequences for the environment and human health.

Any attempt to reverse-engineer this device by decoding proprietary protocols, de-compiling firmware, or any similar actions is strictly prohibited.

SUPPORT & WARRANTY INFORMATION

For the latest documentation and support, please go to: www.resideo.com

For the latest warranty information, please go to: www.security.honeywellhome.com/warranty

The Honeywell Home Trademark is used under license from Honeywell International Inc.
This product manufactured by Resideo Technologies, Inc. and its affiliates



K0903V1H 2/06 Rev. H

resideo

2 Corporate Center Drive, Suite 100
P.O. Box 9040, Melville, NY 11747

© 2020 Resideo Technologies, Inc.
www.resideo.com