



Safety Technology International, Inc.
 2306 Airport Road • Waterford, Michigan 48327-1209
 Phone: 248-673-9898 • Fax: 248-673-1246
 Toll Free: 800-888-4784 • E-mail: info@sti-usa.com
 Web: www.sti-usa.com

Safety Technology International Ltd
 Taylor House • 34 Sherwood Road • Bromsgrove
 Worcestershire • B60 3DR • England
 Tel: +44 (0)1527 520 999 • Fax: +44 (0)1527 501 999
 E-mail: info@sti-europe.com • Web: www.sti-europe.com

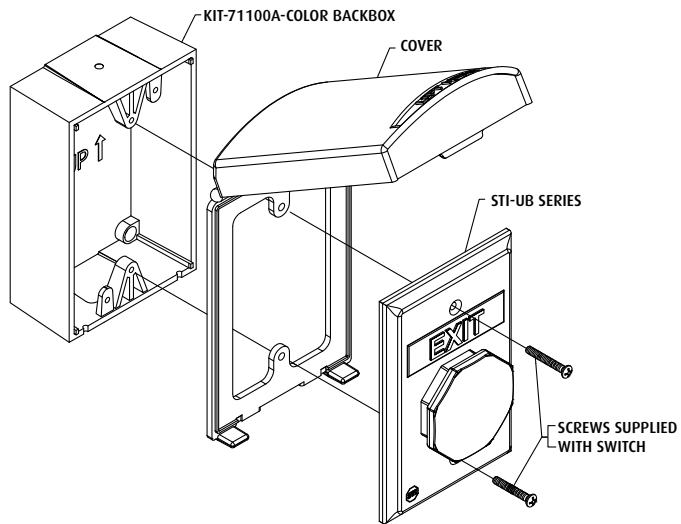

FIGURE 1

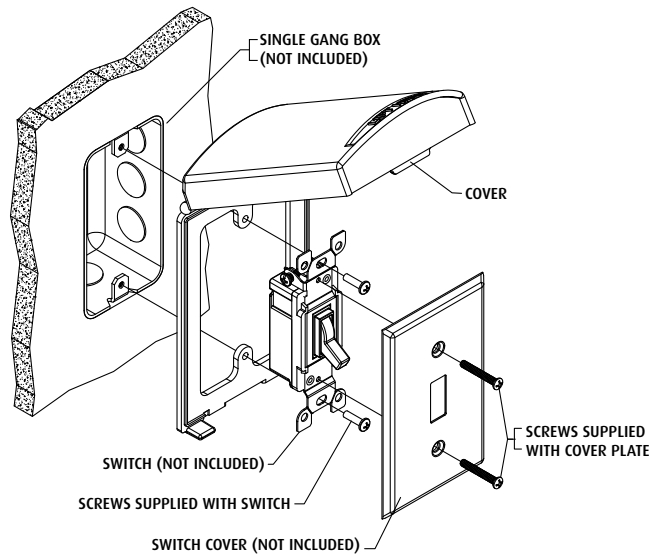

FIGURE 2

INSTALLATION NOTES (FIG. 1 & 2)

1. Place cover with frame on the electrical box.
2. Place switch on the frame of the cover.
3. Insert screws to secure everything together.

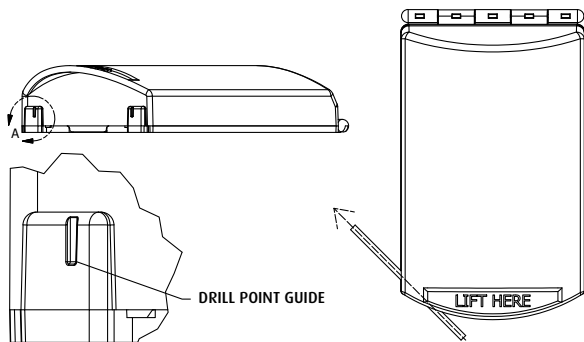
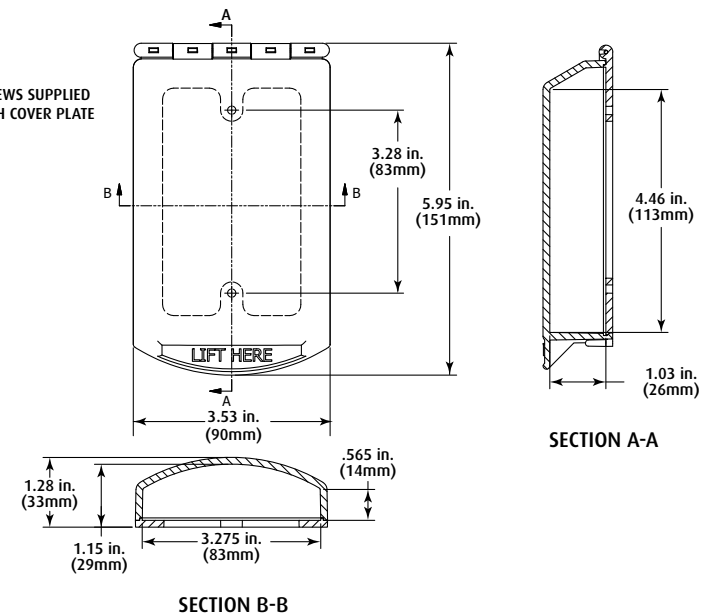

FIGURE 3

OPTIONAL BREAK AWAY TIE INSTALLATION (FIG. 3)

1. Drill before mounting cover to wall.
2. With cover closed, find the drill point guide and use it to locate the drill point center.
3. Use a 1/8" drill bit and drill on a 45° angle through the frame and cover.



DIMENSIONS

Three year warranty or a one year limited warranty (from date of purchase) on most products. See website for details. Electronic warranty form at www.sti-usa.com/wc14.

INSTALLATION OF STI-6519 SINGLE-GANG PROTECTIVE COVER

All specifications and information shown were current as of publication and are subject to change without notice.